

KE-436 B

Electronic Lockstitch Pattern Tacker with Stepping Foot and Programming function

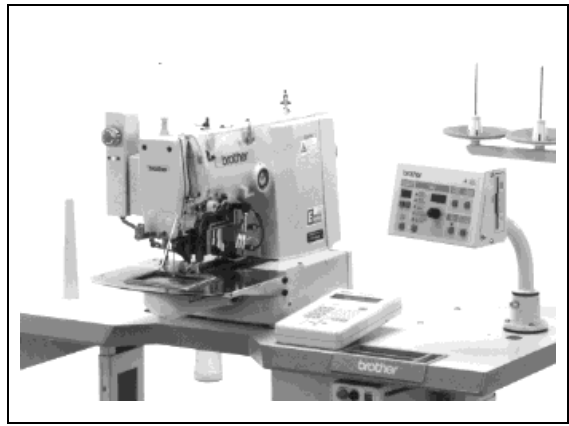

Specifications

Stitch formation	Single needle lock stitch
Maximum sewing speed	2,500 rpm (Pitch 3 mm)
Maximum pattern size (X x Y)	100 x 60 mm max.
Feed mechanism	R-0Intermittent feed mechanism (pulse-motor driven mechanism)
Stitch length	0.1 – 10.0 mm
No. of stitches	Variable
Maximum number of stitches	20,000 stitches (One pattern)
Work clamp lifter	Pneumatic type
Work clamp height	25 mm max.
Rotary hook	Shuttle hook 2 (Shuttle hook, optional)
Wiper device	Standard equipment
Thread trimmer device	Standard equipment
Thread take-up device	Standard equipment
Stepping foot lift amount	18 mm
Stepping foot stroke	0 mm, 3 – 8 mm
Safety device	Built-in stopping mechanism
Data storage method	3.5 floppy disk 2HD / 1.44MB, 2DD
Motor	Three-phase 400 W induction motor
Weights	Machine head: 56 kg, Operation panel: 2.8 kg, Control box: 10 – 20 kg (depending on destination)
Power source	Single-phase 110V, 220 – 230 V, 240V 3-phase 220 V, 380 V, 400 V Maximum electric power consumption; 600 VA

Main use

*Patterns up to a maximum size of 100 mm x 60 mm can be sewn.

For plain stitching of small articles, curtain darts, etc.

*Two-stage work clamp, light work clamp and inner clamping device (optional) can be used.

For attaching items, sewing labels, etc.

Optional parts Foot switch pedal mechanism

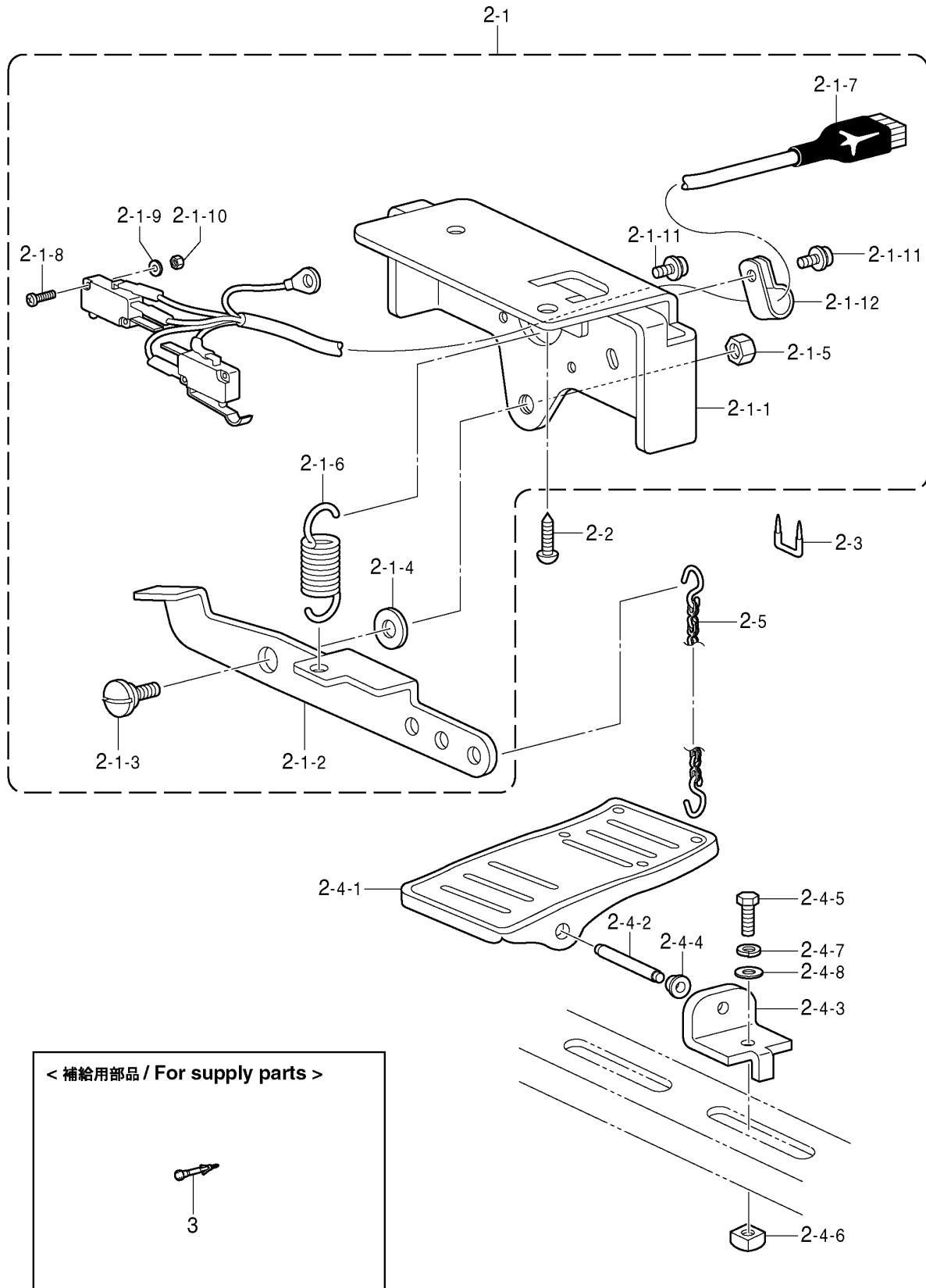





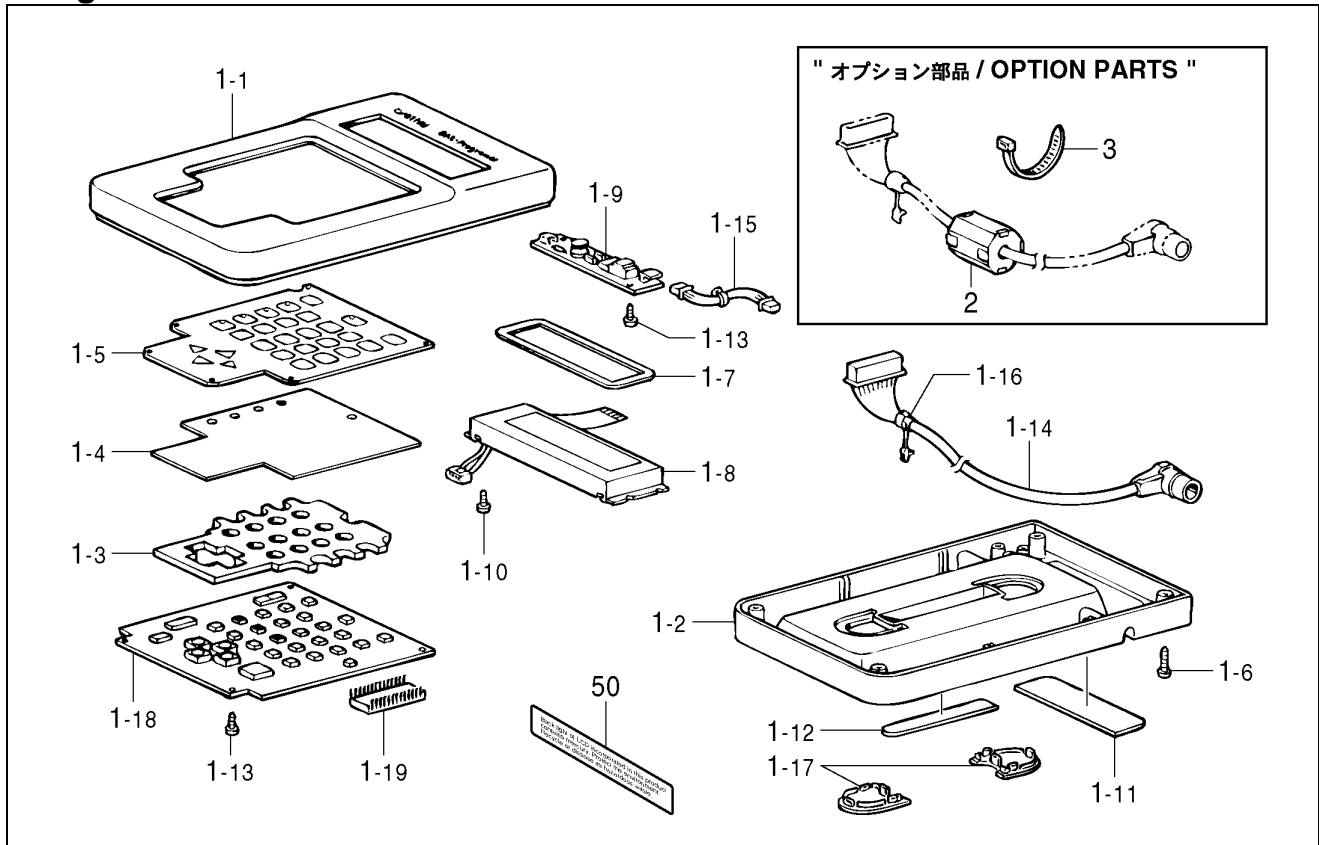







Ref. No.	Part name	Part code	Q'ty
2	2-step foot switch set, OP	S46131-001	1
2-1	2-step foot switch assy, OP	S46132-001	1
2-1-1	Switch bracket	S46133-001	1
2-1-2	Foot SW lever	S46134-001	1
2-1-3	Shoulder screw, SM7.94	148904-001	1
2-1-4	Washer, plain M8	025080-236	1
2-1-5	Nut, SM7.94	101268-002	1
2-1-6	Sprig, extension	S46135-001	1
2-1-7	Foot SW harness assy	S46136-001	1
2-1-8	Screw, pan (S / P washer) M3 × 20	UD2390-001	4
2-1-9	Washer, plain M3	025030-236	2
2-1-10	Nut, 2 M3	021300-206	2
2-1-11	Screw, pan (S / P washer) M4 × 8	052400-806	2
2-1-12	Cord holder, 5 N	S00480-000	1
2-2	Wood screw, round M5.5 × 20	100666-002	2
2-3	Staple	200190-001	3
2-4	Treadle assy	S01603-009	1
2-4-1	Treadle pedal	S01199-003	1
2-4-2	Treadle shaft	133188-001	1
2-4-3	Bracket	119707-003	2
2-4-4	Collar	119708-001	2
2-4-5	Bolt, M8 × 22	017082-206	2
2-4-6	Nut, M8	116694-001	2
2-4-7	Washer, spring 2 - 8	028080-240	2
2-4-8	Washer, plain M8	025080-236	2
2-5	Chain assy	142656-001	1
	<For supply parts>		
3	Contact, ; 170364-1	S49443-000	1

Optional parts Programmer



Ref. No.	Part name	Part code	Q'ty
1	Programmer assy	S43249-001	1
1-1	Top cover, ;programmer	S43250-000	1
1-2	Lower cover, ;programmer	S43251-000	1
1-3	Spacer, ;keyboard	S43252-000	1
1-4	Rubber sheet, ;keyboard	S43253-000	1
1-5	Keyboard sheet	S43254-000	1
1-6	Tapping screw, pan V M3 × 10	037301-015	4
1-7	LCD cover	S43255-000	1
1-8	LCD	S43256-000	1
1-9	Inverter, LCD	S43257-000	1
1-10	Tapping screw, pan V M2 × 6	037200-615	40
1-11	Magnet, A	S43271-000	1
1-12	Magnet, B	S43272-000	1
1-13	Screw, 3 × 6	037300-615	6
1-14	Programmer harness	S43267-000	1
1-15	Inverter harness	S43268-000	1
1-16	Cord bush, ;KR51	S43270-000	1
1-17	Lower cover, programmer	S43981-000	2
1-18	Programmer PCB assy	S43259-001	1
1-19	PROM programmer assy	S43269-000	1
	<For area limitation>		
2	EMI core, ESD-SR-15	S40621-000	1
3	Beard band, L = 200	149809-000	1
	<For area limitation>		
50	Mercury warning label 14 × 70 P2	S52582-001	1



Different parts list

Spec. Part name	Medium materials	Heavy materials	Extra heavy materials
Needle hole plate 	(ϕ 2.2) S49980-001 FM	(ϕ 2.6) S10212-101 E	★
Bobbin case assy 	159610-301 A	152690-401 B	★
		S15902-401 LA	★
Tension spring 	154339-101 A	154340-101 B	★
		S16074-101 LA	★
Screw 		154341-001	★
		S16492-101 LA	★
Spring, anti-spin 	159612-001 A ★	154342-001 B	★
		S15667-001 LA	★
Bobbin 	159613-051	★	154663-001 B ★
		S44633-001 LAN	★
Shuttle hook assy w/box 	152685-903 A ★	152687-902 B	★
	S15662-992 LA ★	S15663-991 LB	★
Shuttle race body 	152682-101 A ★	152686-101 B	★
Spring, tension 	104525-001 ★	107606-001 ★	S06548-001 C
Thread take-up spring 	145519-001 ★	144588-001 B	★
Needle bar thread guide   A B	S41222-101 B ★	S02438-001 A ☆	S02439-001 B ★

★: Common with the LK3-B430E.

☆: Common with the BAS-311E.

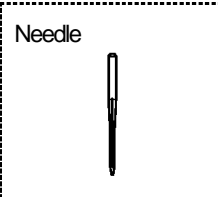
Different parts list

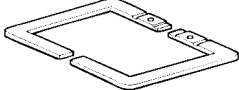
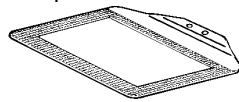
Spec. Part name	Medium materials	Heavy materials	Extra heavy materials
Needle assy 	107415-414 ★	S37928-419 ★	145646-425 ☆
Needle 	DP × 5 #14 107415-014 ★	DP × 17 NY #19 S37928-019 ★	DP × 17 #25 145646-025 ☆
Work clamp 	-	434ESF-2R S46544-001	-
		S434ESF-2L S46545-001	
Feed plate 	-	434ESF-2 S44942-001	-

★: Common with the LK3-B430E.

☆: Common with the BAS-311E.

Gauge parts list

Optional gauges are listed in the following table.

Each work clamp pair is used in combination with the feed plate directly below them.

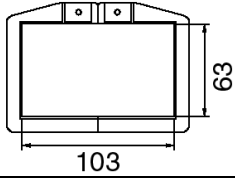
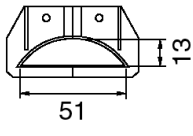
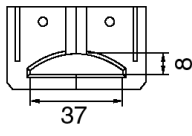
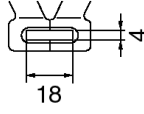
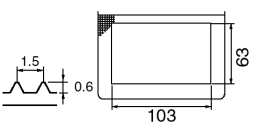
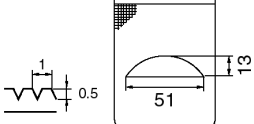
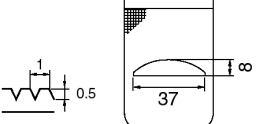
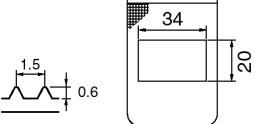
	1	2	3	4
R	153493-001	S23377-001 (519)	S27836-001 (895)	156085-001 (M)
L	153498-001	S23378-001 (519)	S27837-001 (895)	156086-001 (M)
Work clamp,				
Feed plate	153503-001 	S23379-001 (519) 	S27838-001 (895) 	156087-001 (M) 

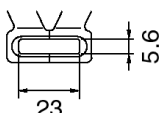
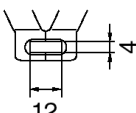
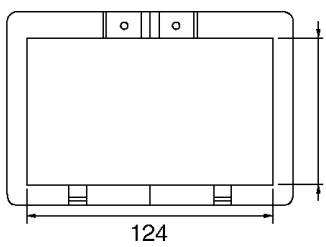
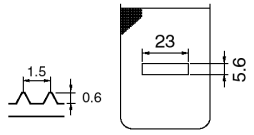
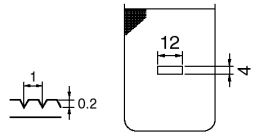
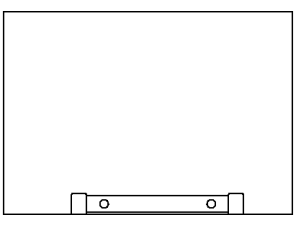
	5	6	7		
R	156082-001 (L)	156088-001 (S)	S44940-001 (434E SF)		
L	156083-001 (L)	156089-001 (S)	S44941-001 (434E SF)		
Work clamp,					
Feed plate	156084-001 (L) 	156090-001 (S) 	S43990-001 (A)	S43991-001 (B)	S43992-001 (C) 
			A: t=0.5 B: t=1.0 C: t=2.0		

Gauge assy, 434E MK2

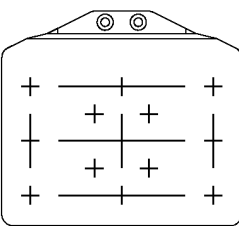
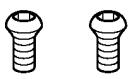
Gauge assy, 434E MK2	
S54984-001	
Home position standard plate 	Screw 

Gauge parts list

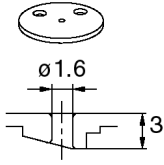
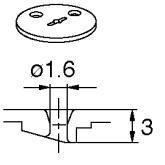
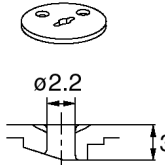
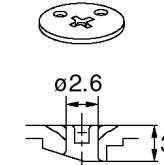
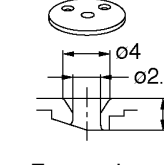
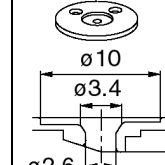
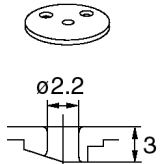
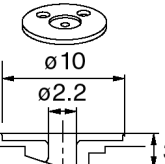
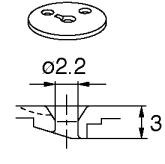
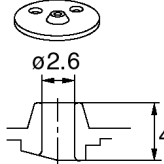
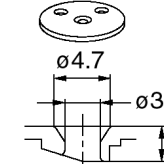
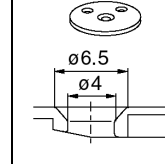
Needle hole plate											
A	S10211-001	AF	S51449-001	BZ	S41013-001	D	S29997-001	E	S10212-101	ED	S30925-001
							For extra heavy & heavy materials				
F	S10213-001	FD	S30926-001	FM	S49980-001	H	S30450-001	L	S25127-001	M	S34348-001
							For medium materials				
3	S40217-001										
	