

# BES-960BC BES-1260BC

SERVICE MANUAL

BROTHER  
EMBROIDERY  
SYSTEM



---

Please read this manual before making any adjustments.

---

NINE NEEDLE SIX HEAD ELECTRONIC EMBROIDERY MACHINE  
TWELVE NEEDLE SIX HEAD ELECTRONIC EMBROIDERY MACHINE

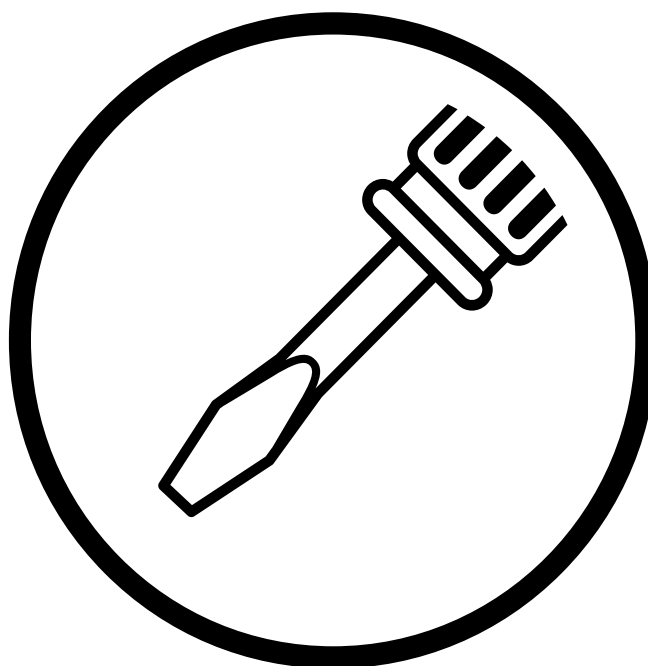

---

**brother**<sup>®</sup>

This service manual is intended for BES-960BC, 1260BC; be sure to read the BES-960BC, 1260BC instruction manual before this manual.

Carefully read the "SAFETY INSTRUCTIONS" below and the whole of this manual to understand this product before you start maintenance.

As a result of research and improvements regarding this product, some details of this manual may not be the same as those for the product you purchased.

If you have any questions regarding this product, please contact a Brother dealer.

## SAFETY INSTRUCTIONS

### 1 Safety indications and their meanings

This instruction manual and the indications and symbols that are used on the machine itself are provided in order to ensure safe operation of this machine and to prevent accidents and injury to yourself or other people. The meanings of these indications and symbols are given below.

#### Indications



#### DANGER

The instructions which follow this term indicate situations where failure to follow the instructions will almost certainly result in death or severe injury.



#### CAUTION

The instructions which follow this term indicate situations where failure to follow the instructions could cause injury when using the machine or physical damage to equipment and surroundings.

#### Symbols



..... This symbol () indicates something that you should be careful of.  
The picture inside the triangle indicates the nature of the caution that must be taken. (For example, the symbol at left means "beware of injury".)



..... This symbol () indicates something that you must not do.



..... This symbol () indicates something that you must do.  
The picture inside the circle indicates the nature of the thing that must be done.  
(For example, the symbol at left means "you must make the ground connection".)

## 2 Notes on safety

### DANGER



Wait at least 5 minutes after turning off the power switch and disconnecting the power cord from the wall outlet before opening the face plate of the control box. Touching areas where high voltages are present can result in severe injury.

### CAUTION

#### Installation



Machine installation should only be carried out by a qualified technician.



Contact your Brother dealer or a qualified electrician for any electrical work that may need to be done.



The sewing machine weighs more than 720 kg. The installation should be carried out by four or more people.



Do not connect the power cord until installation is complete, otherwise the machine may operate if the start switch is pressed by mistake, which could result in injury.



Be sure to connect the ground. If the ground connection is not secure, you run the risk of receiving a serious electric shock.



When securing the cords, do not bend the cords excessively or fasten them too hard with staples, otherwise there is the danger that fire or electric shocks could occur.



Be sure to wear protective goggles and gloves when handling the lubricating oil or grease, so that no oil or grease gets into your eyes or onto your skin, otherwise inflammation can result.

Furthermore, do not drink the oil or grease under any circumstances, as they can cause vomiting and diarrhoea.

Keep the oil out of the reach of children.



Avoid setting up the sewing machine near sources of strong electrical noise such as high-frequency welding equipment.

If this precaution is not taken, incorrect machine operation may result.



The casters should be secured in such a way so that they cannot move.

#### Sewing



This sewing machine should only be used by operators who have received the necessary training in safe use beforehand.



The sewing machine should not be used for any applications other than sewing.



Turn off the power switch at the following times, otherwise the machine may operate if the start switch is pressed by mistake, which could result in injury.

- When threading the needle
- When replacing the bobbin and needle
- When not using the machine and when leaving the machine unattended



Do not get on the table.



Table may be damaged.

Attach all safety devices before using the sewing machine. If the machine is used without these devices attached, injury may result.



Do not touch any of the moving parts or press any objects against the machine while sewing, as this may result in personal injury or damage to the machine.



Do not touch the pulse motor and sewing machine bed section during operation or for 30 minutes after operation. Otherwise burns may result.



If an error occurs in machine operation, or if abnormal noises or smells are noticed, immediately turn off the power switch. Then contact your nearest Brother dealer or a qualified technician.



If the machine develops a problem, contact your nearest Brother dealer or a qualified technician.

## CAUTION

### Cleaning



Turn off the power switch before starting any cleaning work, otherwise the machine may operate if the start switch is pressed by mistake, which could result in injury.



Be sure to wear protective goggles and gloves when handling the lubricating oil or grease, so that no oil or grease gets into your eyes or onto your skin, otherwise inflammation can result. Furthermore, do not drink the oil or grease under any circumstances, as they can cause vomiting and diarrhoea. Keep the oil out of the reach of children.

### Maintenance and inspection



Maintenance and inspection of the sewing machine should only be carried out by a qualified technician.



If the power switch needs to be left on when carrying out some adjustment, be extremely careful to observe all safety precautions.



Ask your Brother dealer or a qualified electrician to carry out any maintenance and inspection of the electrical system.



Use only the proper replacement parts as specified by Brother.



Turn off the power switch and disconnect the power cord from the wall outlet at the following times, otherwise the machine may operate if the treadle is depressed by mistake, which could result in injury.



If any safety devices have been removed, be absolutely sure to re-install them to their original positions and check that they operate correctly before using the machine.

- When carrying out inspection, adjustment and maintenance
- When replacing consumable parts such as the rotary hook and knife.



Any problems in machine operation which result from unauthorized modifications to the machine will not be covered by the warranty.

This service manual gives explanations for the following two models:

- BES-960BC (9 needle)
- BES-1260BC (12 needle)

Description limited to either model is given with the appropriate model name.  
Before reading this manual, check your machine's model name.

## CONTENTS

Chapter 1 Mechanical Descriptions .....	1
1. Feed guide mechanism .....	1
2. Crank shaft mechanism .....	2
3. Lower shaft and rotary hook mechanisms .....	3
4. Thread trimmer mechanism .....	4
5. Thread take-up mechanism .....	5
6. Needle bar mechanism .....	6
7. Needle bar flip-up mechanism .....	7
8. Presser foot lifter mechanism .....	8
9. Thread wiper mechanism .....	9
10. Cap frame device .....	10
Chapter 2 Parts Replacement and Adjustment .....	11
1. Replacing and adjusting the machine heads .....	11
2. Removing the needle bar case .....	18
3. Replacing and adjusting the thread take-up lever .....	19
4. Replacing the needle bar .....	20
5. Replacing the jump bracket .....	21
6. Replacing and adjusting the jump solenoid .....	22
7. Replacing the rotary encoder and the sensor PCB .....	23
8. Replacing timing belt X .....	24
9. Replacing timing belt Y .....	25
10. Replacing the driving wire .....	27
11. Replacing and adjusting the presser lifter parts .....	28
11-1. Presser foot .....	28
11-2. Presser foot shaft .....	28
11-3. Replacing and adjusting the W retracting lever and the RET motor lever .....	30
11-4. Replacing and adjusting the pulse motor .....	31

12. Replacing and adjusting the gears related to the needle bar flip-up mechanism .....	32
13. Replacing and adjusting the potentiometer .....	34
14. Replacing and adjusting the movable and fixed knives .....	37
15. Replacing and adjusting the lower shaft module .....	38
16. Replacing the presser foot switch .....	41
17. Replacing and adjusting the solenoid that controls pulley .....	42
Chapter 3 Standard Adjustment .....	43
1. Adjusting Needle Bar Height .....	43
When using the bottom dead center gauge .....	45
2. Adjustment of Clearance Between Needle and Rotary Hook .....	47
3. Adjustment of Timing Between Needle and Rotary Hook.....	48
4. Adjusting the clearance between the rotary hook and the inner rotary .....	50
5. Adjustment of Presser Foot Height .....	51
Adjusting the position of the presser shaft.....	51
6. Adjustment of Thread Trimmer .....	52
6-1. Attaching the Fixed Knife .....	52
6-2. Checking the Movable Knife Position .....	52
7. Adjusting the thread wiper.....	55
8. Adjusting the jump solenoid .....	56
9. Adjusting the switch.....	57
10. Adjusting the timing belt tension .....	61
10-1. Timing belt X .....	61
10-2. Timing belt Y .....	62
11. Adjusting the driving wire .....	65
12. Adjusting the Y carriage .....	66
12-1. When the sliding resistance of the Y-carriage is below the standard value .....	67
12-2. When the sliding resistance of the Y-carriage is over the standard value .....	68
12-3. When the sliding resistance of the Y-carriage is over the standard value even after adjustment 2 .....	69
12-4. When linear guide 505L, which is attached to machine head No.3, is not parallel to the top surface of the bed .....	69
13. Adjusting the rotary encoder and sensor PCB .....	70
13-1. Adjusting the machine stop position signal .....	70
13-2. Adjusting the synchronizing signal .....	71
14. Adjusting the bobbin winder.....	72
14-1. Positioning the bobbin winder claw .....	72
14-2. Positioning the bobbin presser .....	72
15. Adjusting the wire of the cap frame attachment .....	73
15-1. Adjusting the wire tension .....	73
15-2. Adjusting the feed roller .....	74

15-3. Adjusting cap support plates L and R .....	74
15-4. Adjusting the presser foot height .....	75
Chapter 4 Test mode .....	76
[Test mode on the operation panel] .....	76
1. Starting test mode .....	76
2. Selecting test mode menu .....	76
3. Test mode functions .....	77
3-1. Thread trimmer adjustment .....	77
3-2. Needle bar case test .....	77
3-3. Home position searching test .....	78
3-4. Encoder signal test.....	78
3-5. Switch and LED test on operation panel and head .....	79
3-6. Presser foot test .....	80
3-7. Solenoid test .....	80
3-8. Driving shaft rotation test .....	81
3-9. Stitch compensation .....	81
3-10. Adjusting the timing between the needle and the rotary hook.....	83
3-11. Program version indication on the operation panel and head display .....	83
3-12. Power voltage and frequency indication .....	84
3-13. Port check.....	85
3-14. 7 segment LED indication test .....	86
3-15. Machine head communication test .....	86
3-16. Error sound switching .....	86
3-17. Automatic start at the end of mending .....	86
[Test mode and each function on the PC].....	87
1. PC test mode .....	87
2. Confirming the program version .....	88
3. Confirming and deleting the BC error .....	92
4. BC sensor test .....	94
5. Lower shaft module test (BC auto test).....	97
6. Power supply voltage adjustment .....	99
Chapter 5 Upgrading version of machine program .....	101
Chapter 6 Maintenance .....	104
1. Cleaning Rotary Hook .....	104
2. Oiling .....	105
2-1. Head.....	105

3. Greasing .....	107
3-1. Head.....	107
3-2. Feed Guide Section.....	111
 Chapter 7 Electric Components .....	 112
1. PCBs locations .....	112
2. Replacing the PCBs in the control box.....	114
2-1. Removing and reattaching the control box .....	114
2-2. Removing and reattaching the control box cover.....	114
2-3. Replacing the main PCB .....	115
2-4. Replacing the power supply PCB .....	116
3. Replacing power supply PCB B in the power supply base.....	117
3-1. Removing and attaching the leg cover and the power supply base cover.....	117
3-2. Replacing power supply PCB B in the power supply base .....	118
4. Replacing the head switch PCB on the adjustment base .....	119
4-1. Removing and reattaching the adjustment base cover .....	119
4-2. Replacing the head switch PCB .....	121
4-3. Removing the TR breakage sensor PCB .....	122
5. Replacing the head PCB .....	124
6. Replacing the BC PCB.....	125
7. Replacing the BC sensor PCB .....	126
8. Replacing the panel PCB .....	127
9. Replacing the Y-feed sensor PCB .....	128
10. Replacing the X-feed sensor PCB.....	129
11. Replacing the retracting bed sensor PCB .....	130
12. Replacing the thread trimming sensor PCB .....	131
13. Replacing the cooling fans.....	132
13-1. Replacing the control box fan .....	132
13-2. Replacing the main PCB fan .....	133
13-3. Replacing the power supply PCB fan .....	133
14. Fuses .....	134
14-1. Fuse positions.....	134
14-2. Fuse type and capacity .....	135
14-3. Replacing the fuses .....	137
15. Handling the circuit protector of the bobbin winder (optional) .....	138
16. P-ROM position .....	139
17. Connectors .....	140
17-1. Main PCB connectors.....	140
17-2. Connectors in power supply PCB in the control box.....	151
17-3. Connectors in power supply PCB B in power supply base.....	158



17-4. Connector in panel PCB .....	159
17-5. Connectors in BC PCB .....	160
17-6. Connectors in head PCB .....	163
17-7. Connectors on the rear of the control box .....	167
Chapter 8 Finding Cause of Problem .....	170
1. Mechanical problems .....	170
2. Electrical parts .....	171
Chapter 9 Error code list .....	180
Test mode menu list .....	184
Control Block Diagram (BES-960BC, 1260BC) .....	185
Control box (BES-960BC, 1260BC) .....	186
Heads (1-6) (BES-960BC) .....	187
Heads (1-6) (BES-1260BC) .....	188

# Chapter 1 Mechanical Descriptions

## 1. Feed guide mechanism

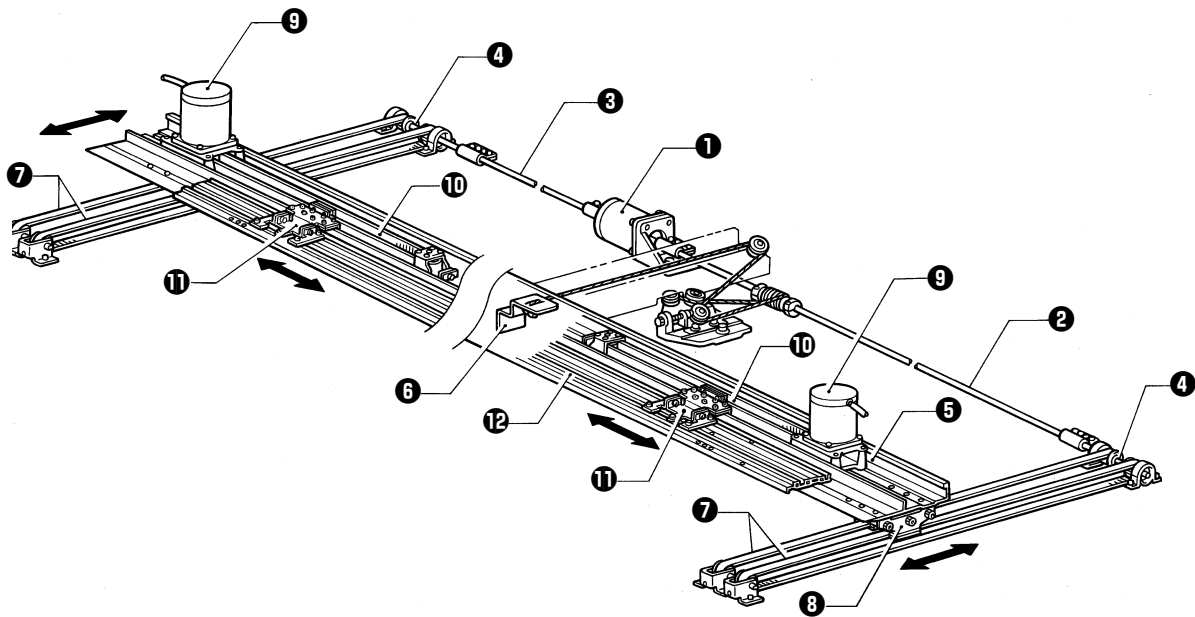

### [Y direction]

When the Y-pulse motor **1** starts, its motion is transmitted to connecting shafts A **2** and B **3**, and the Y driving shaft **4**. The rail connecting plate **6** secured to the Y-feed frame **5** moves the wire, and the Y carriage **8** attached to the Y timing belts **7** moves the Y-feed frame **5** in the Y direction.

### [X direction]

When the X pulse motor **9** starts, its motion is transmitted to the X timing belt **10**, and the X-feed bracket **11**, resulting in causing the X-feed frame **12** to move in the X direction.

## 2. Crank shaft mechanism

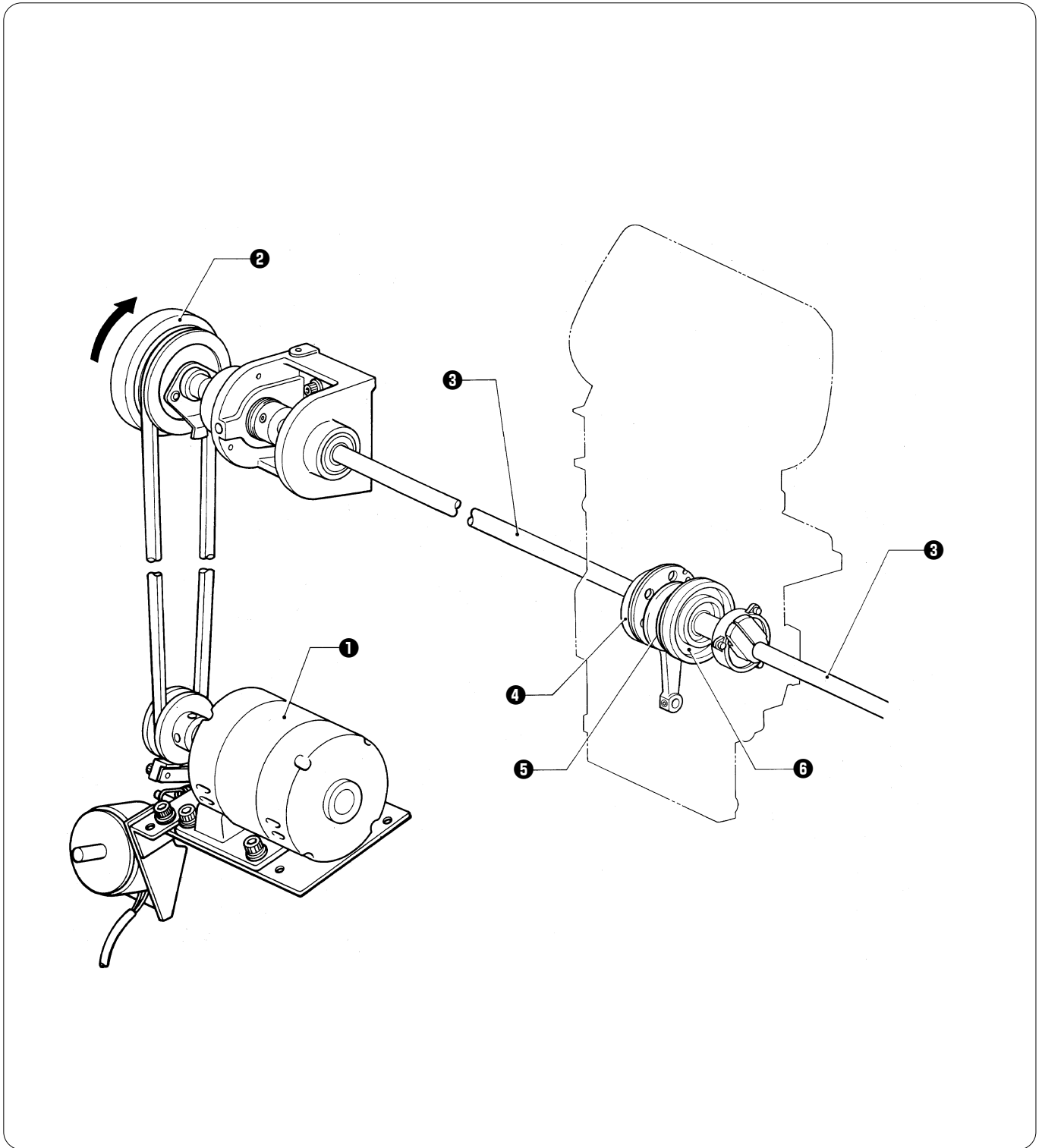

When the motor ① starts, pulley B ② is rotated via the V-belt, resulting in causing the driving shaft ③ to rotate the thread take-up cam ④, the needle bar driving cam ⑤, and the work clamp cam ⑥.

### 3. Lower shaft and rotary hook mechanisms

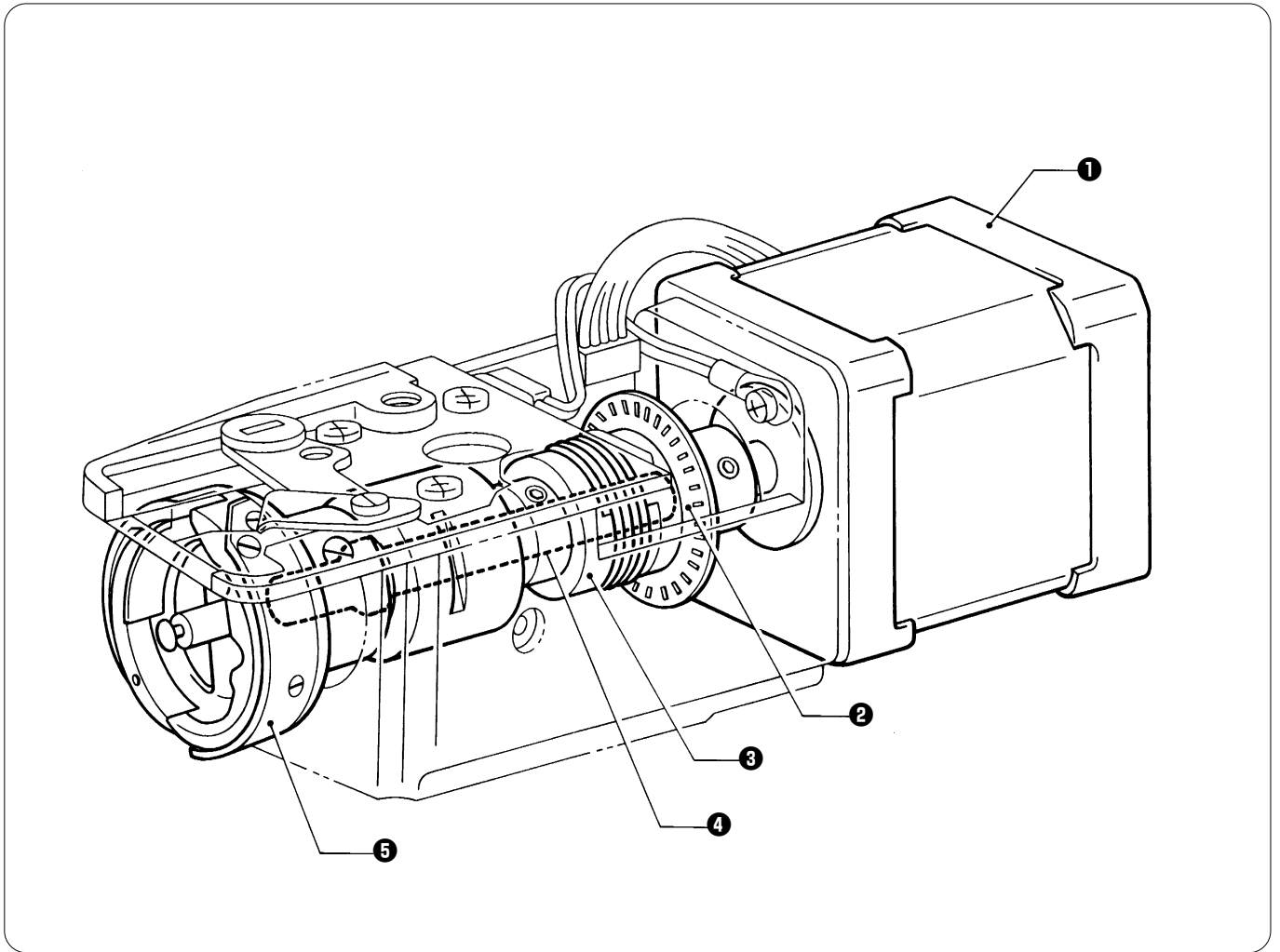

When pulley B and the crank shaft rotate, the pulse motor ① of the lower shaft module is synchronized with the upper shaft by the coupling hub assembly R ②, and rotates the coupling hub ③, the lower shaft ④, and the rotary hook ⑤.

## 4. Thread trimmer mechanism

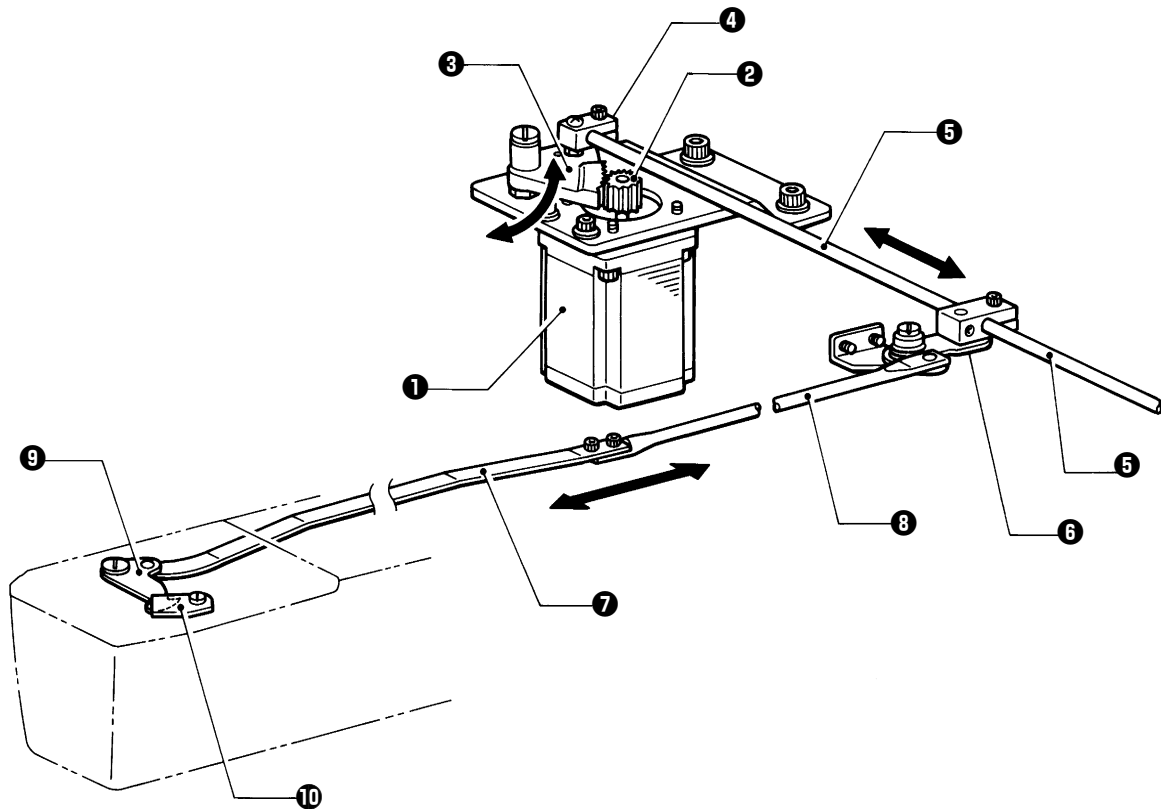

- When the pulse motor ① receives the signal for the final stitch, TR gear C ② rotates, and gear A TR ③ rocks.
- The motion of TR gear A ③ is transmitted to connecting block TR ④, resulting in causing the two TR connecting rods ⑤ to move to the right and left.
- The motion of TR connecting rods ⑤ is transmitted to the thread trimmer lever ⑥, resulting in causing TR connecting rod assys B ⑦ and C ⑧ to move back and forth.
- When TR connecting rod assys B ⑦ and C ⑧ move back and forth, the movable knife ⑨ and the fixed knife ⑩ engage with each other to trim the thread.

## 5. Thread take-up mechanism

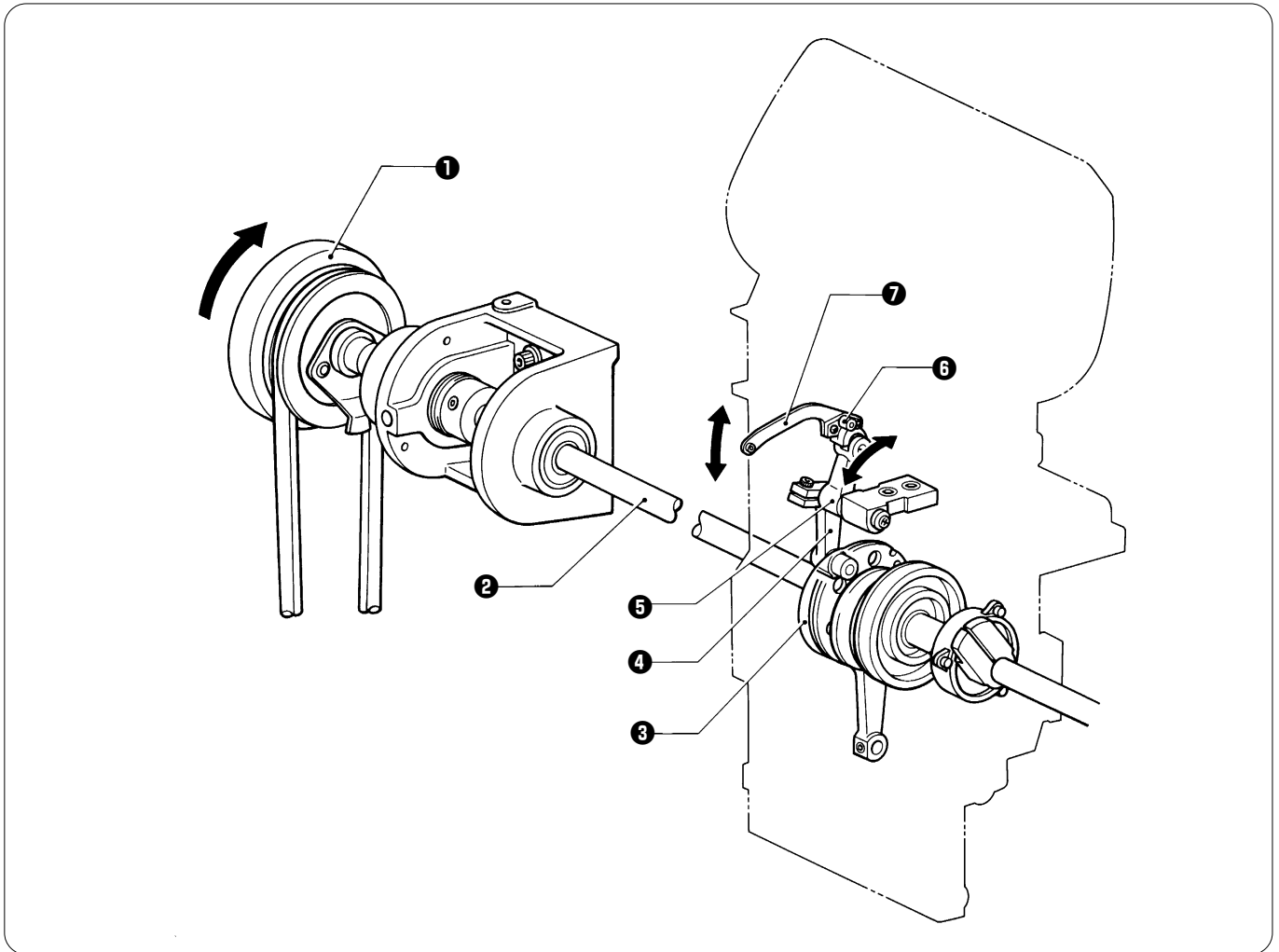

- When pulley B **1** rotates in the direction of the arrow, the motion is transmitted to the crank shaft **2**, and the thread take-up driving cam **3** rotates.
- The thread take-up driving cam **3** rocks the lever **5** via the roller of the TR take-up driving lever assembly **4**.
- The lever **5** moves the thread take-up lever **7** via the thread take-up boss **6**.

## 6. Needle bar mechanism

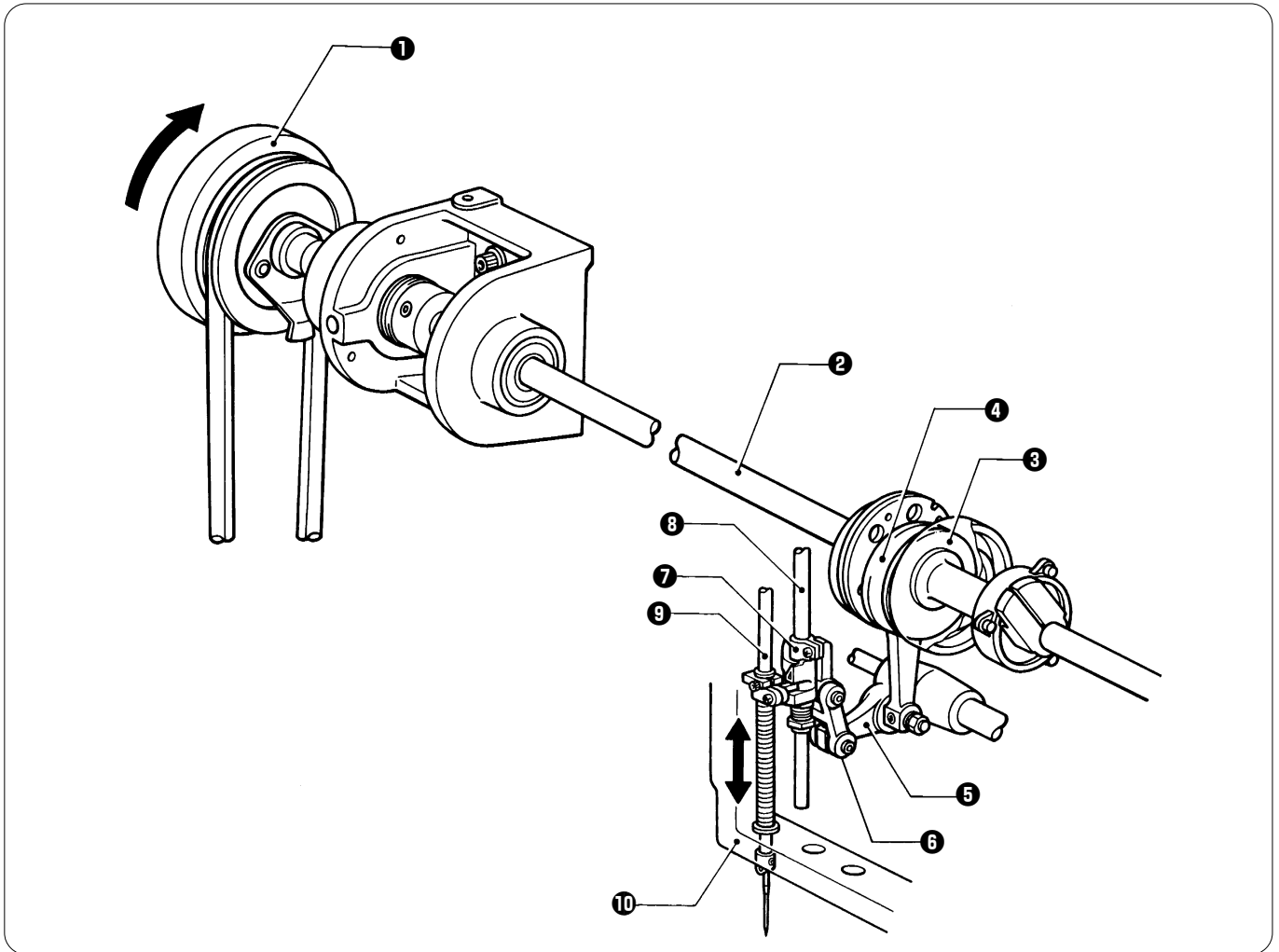

- When the pulley B **1** rotates in the direction of the arrow, the driving shaft **2** rotates the needle bar driving cam **3**.
- The connecting rod **4** is connected to the needle bar driving cam **3**.
- The connecting rod **4** moves the needle bar driving lever **5**, and the base needle bar **8** attached to the jump bracket **7** and the needle bar **9** move up and down via the driving connector **6**.
- The motion of the needle bar **9** depends on the needle bar case **10**.

## 7. Needle bar flip-up mechanism

### ■ BES-960BC

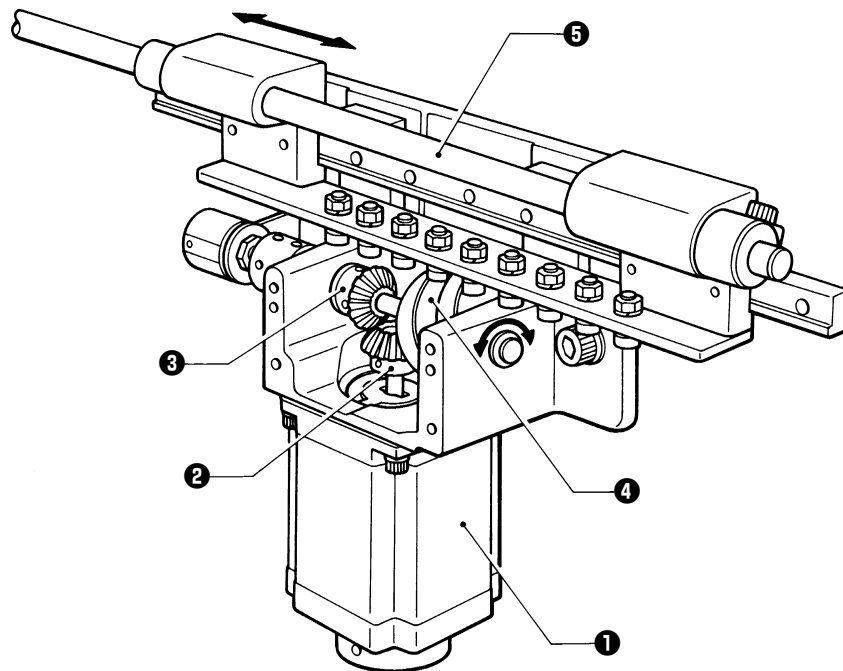

### ■ BES-1260BC

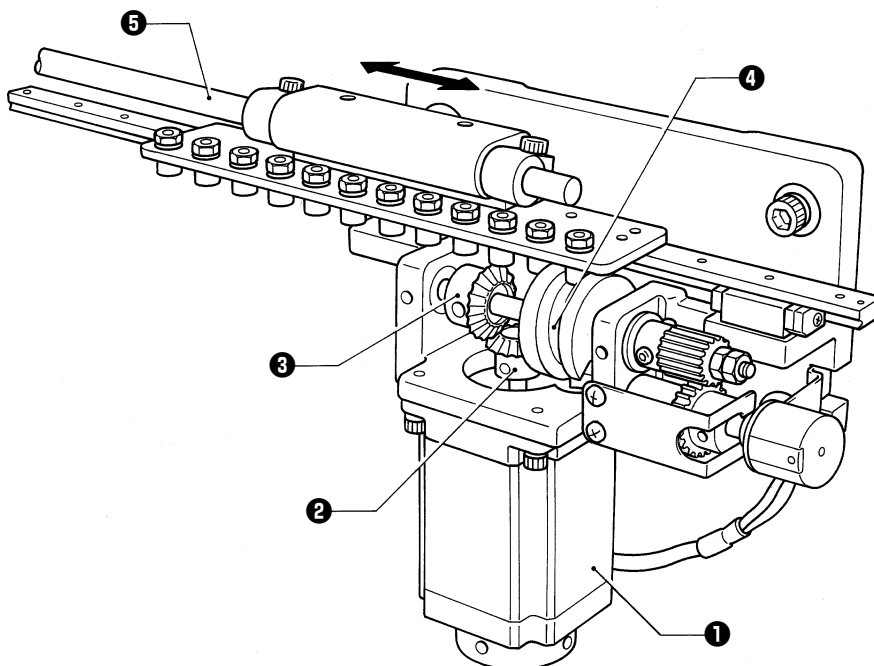

- The needle bar flip-up signal is transmitted to the pulse motor ① to activate bevel gears A ② and B ③.
- The change cam ④ switches needle bars.
- The needle bar flip-up is sent to all six machine heads via the connecting shaft ⑤.



## 8. Presser foot lifter mechanism

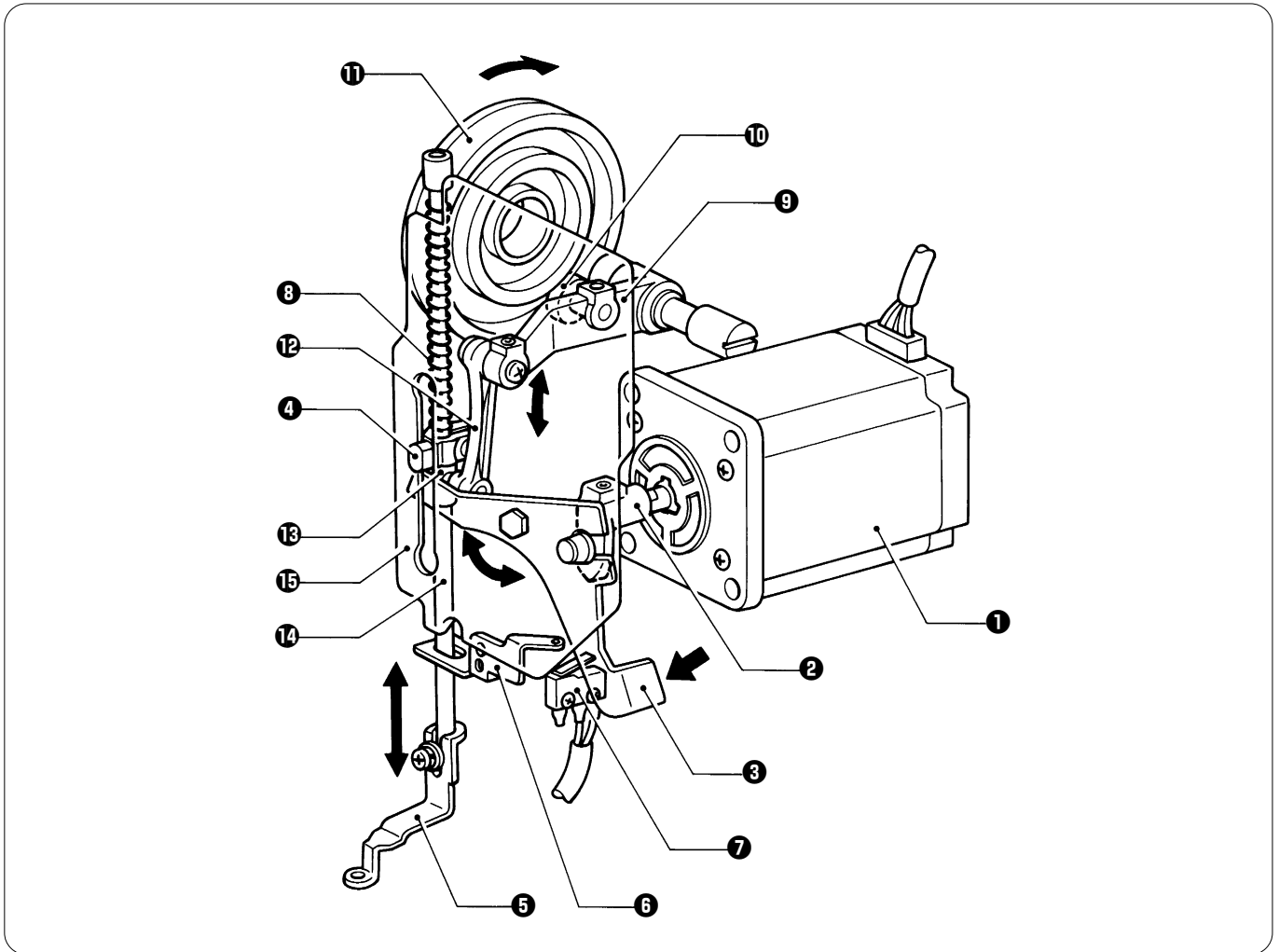

- When the power is turned on, the pulse motor **1** receives a signal, the RET motor lever **2** works, the W retracting lever **3** raises the presser foot shaft clamp **4** and the presser foot **5** to a position decided by W motor sensor plate **6** and the W switch assy **7**.
- When sewing starts, the pulse motor **1** is off, and the presser foot **5** is lowered by the retracting spring **8**.
- The roller **10**, which is attached to the presser foot driving lever **9** and inserted into the groove of the work clamp cam **11**, transmits the motion to the link **12**.
- The presser foot operating base **13** set in the link **12** and the presser foot shaft clamp **4** secured to the presser foot shaft **14** are connected by the retracting spring **8**. They move the presser foot **5** up and down along the groove of the presser guide plate **15**.
- When sewing is completed, the pulse motor **1** receives a signal, and raises the presser foot **5** to a position decided by W motor sensor plate **6** and the W switch assy **7**.
- While the power is turned off, the presser foot **5** can be raised manually by pressing the W retracting lever **3**.

## 9. Thread wiper mechanism

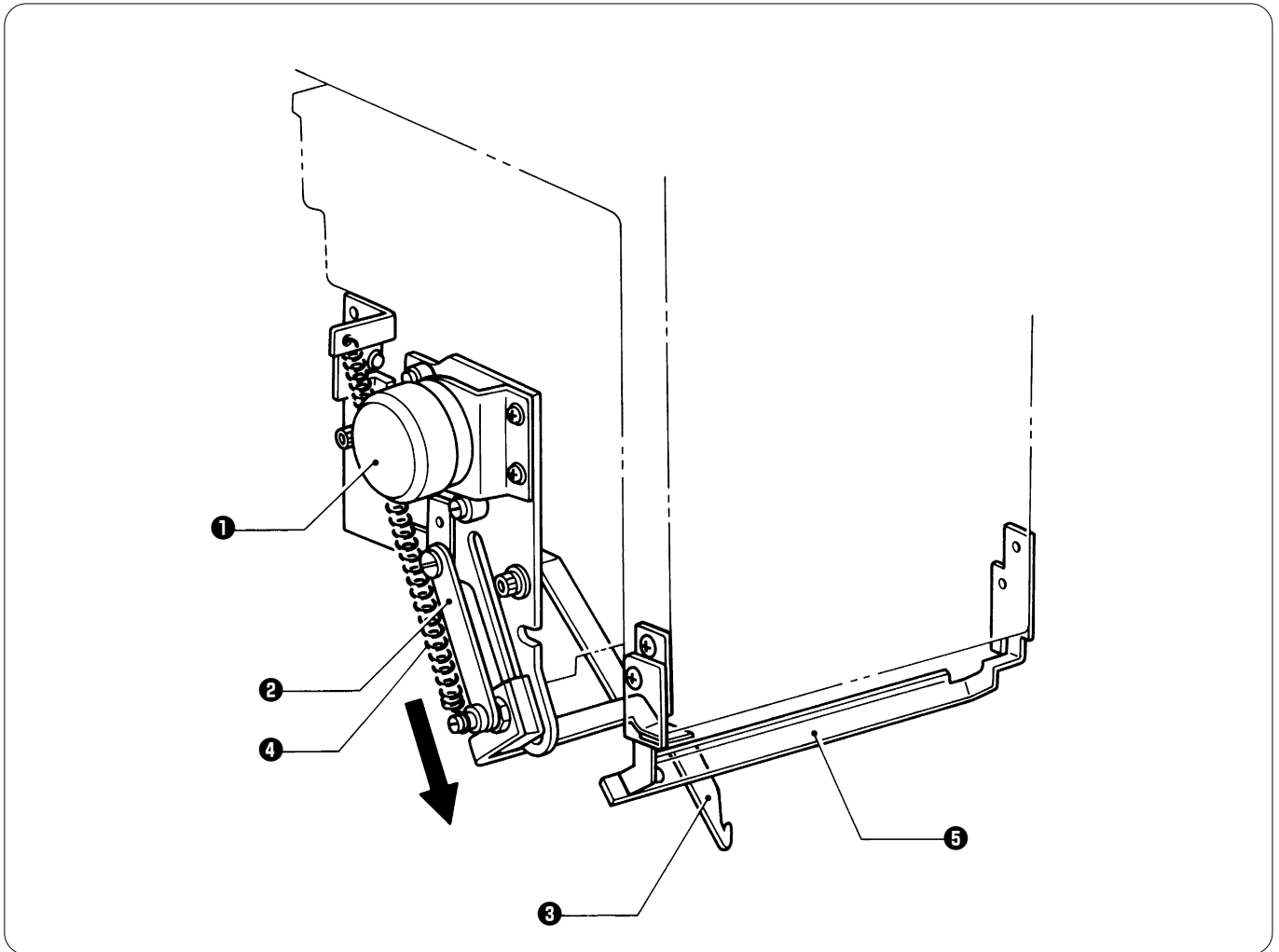

- After sewing is finished, the wiper solenoid **1** moves the plate **2** in the direction of the arrow.
- The upper thread guide hook **3** attached to the plate **2** trims the upper thread. The trimmed thread is raised by the spring **4**, and maintained in a position on the thread presser base **5**.

## 10. Cap frame device

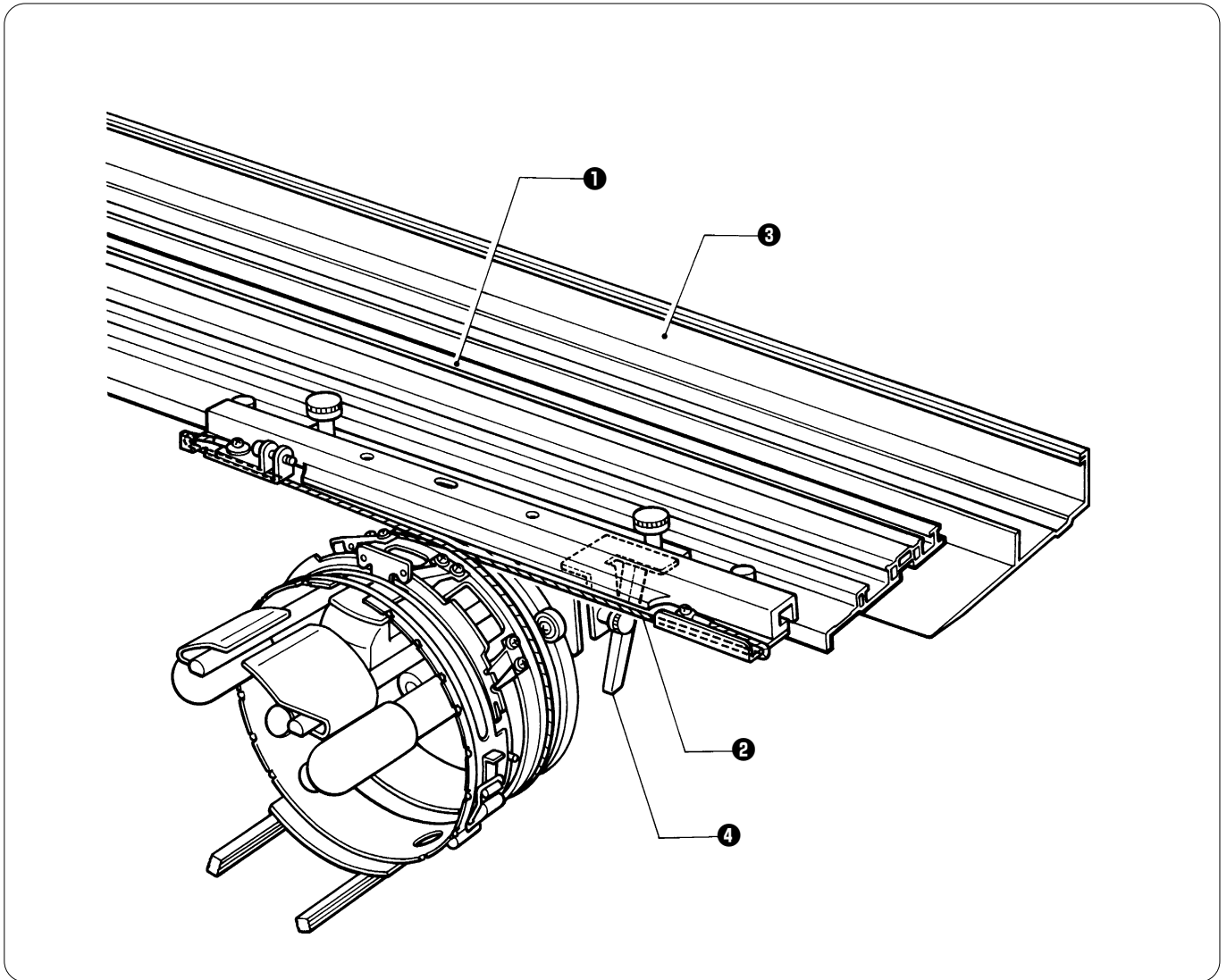

- When the X-feed frame ① moves in the direction of X, the cap frame device is rotated by the wire ②.
- When the Y-feed frame ③ moves in the direction of Y, the motion is transmitted to the cap frame device via the fixed lever ④.

# Chapter 2 Parts Replacement and Adjustment

## ⚠ CAUTION



Turn off the power switch before starting any cleaning work, otherwise the machine may operate if the start switch is pressed by mistake, which could result in injury.



Maintenance and inspection of the sewing machine should only be carried out by a qualified technician.



Turn off the power switch and disconnect the power cord from the wall outlet at the following times, otherwise the machine may operate if the treadle is depressed by mistake, which could result in injury.

- When carrying out inspection, adjustment and maintenance



If the power switch needs to be left on when carrying out some adjustment, be extremely careful to observe all safety precautions.



Use only the proper replacement parts as specified by Brother.



If any safety devices have been removed, be absolutely sure to re-install them to their original positions and check that they operate correctly before using the machine.



Any problems in machine operation which result from unauthorized modifications to the machine will not be covered by the warranty.

## 1. Replacing and adjusting the machine heads

### Notes:

Be sure to lower table F when it has been used.

Remove all connectors and the like which are attached to the machine heads.

Be sure to replace machine heads one by one. Do not remove two or more heads at once.

Do not remove anything but the feed mechanism.

[Removing a machine head]

BES-960BC

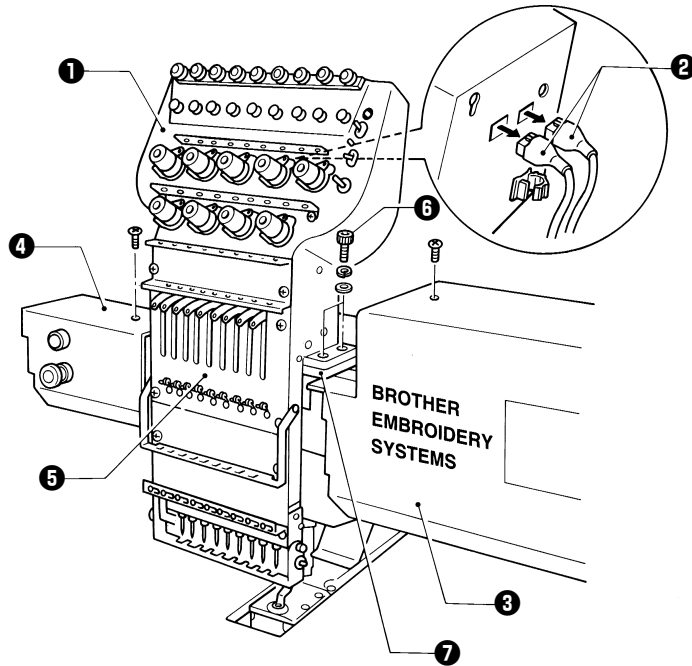

BES-1260BC

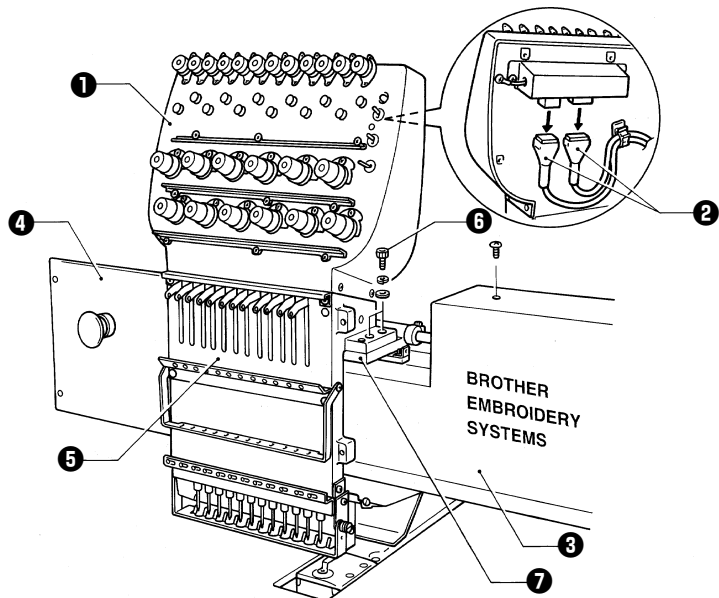

1. Remove the two connectors ② from the rear of the adjustment base ①. (At this time, separate cords from cord clamps.)
2. Remove screws, the cover ③, and the switch cover ④. (Remove the covers for remaining machine heads ⑦.)
3. Remove the four bolts ⑥, and the needle bar case ⑤ from the machine head ⑦.

Note:

When removing the switch cover ④, remove switch connectors.

BES-960BC

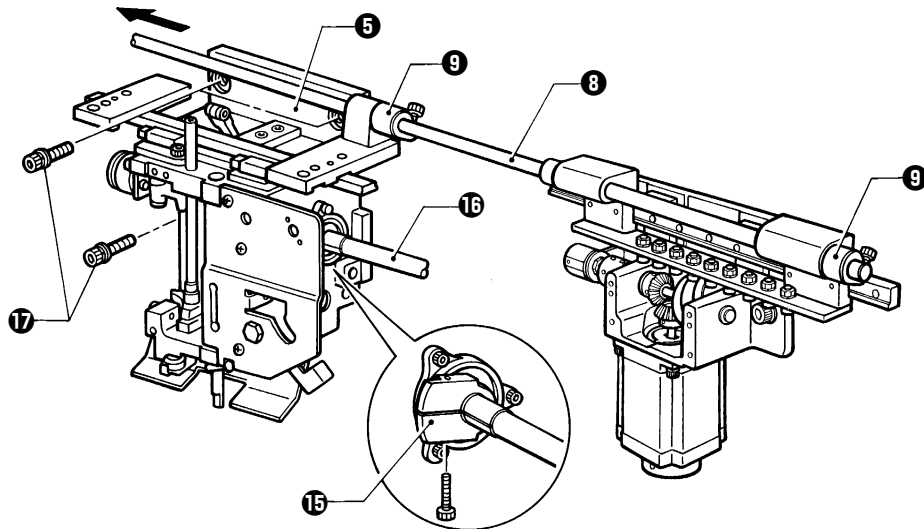

BES-1260BC

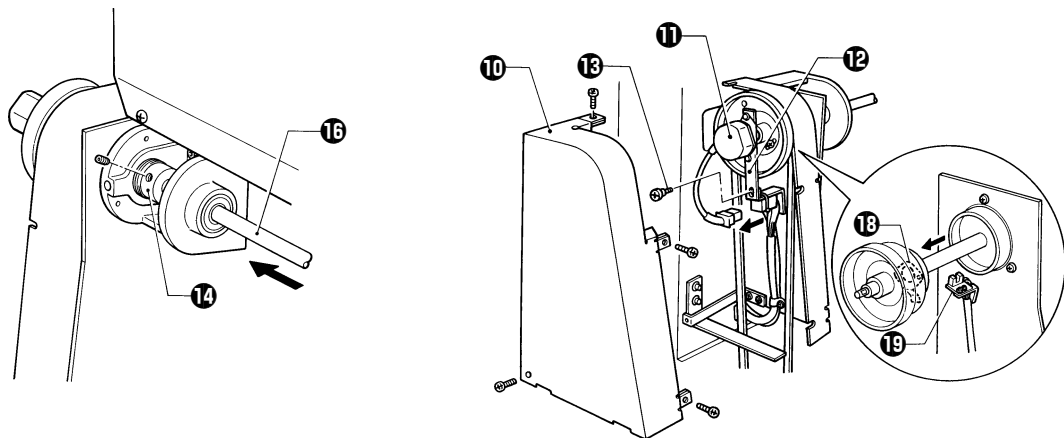
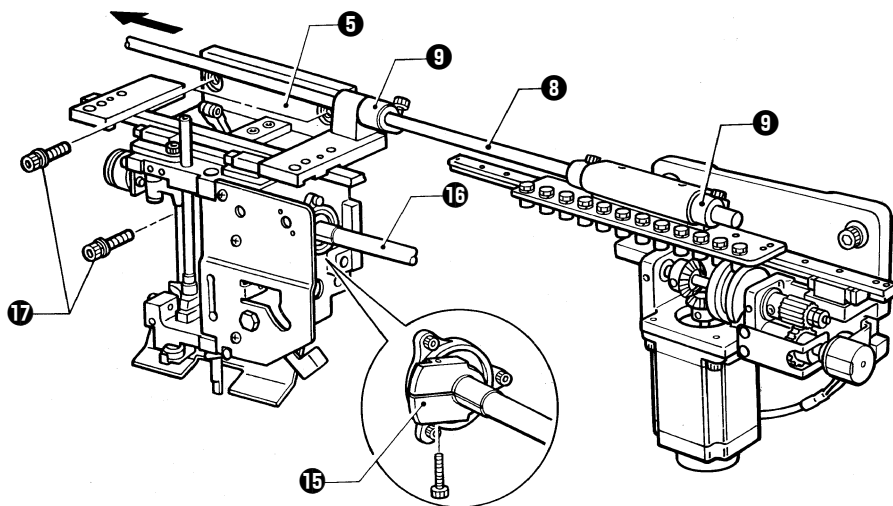

4. Loosen the **14** bolts of the **14** change bracket collars **9** securing the connecting shaft **8**, and pull the connecting shaft **8**.
5. Remove belt cover B **10**, and then the connector of the rotary encoder **11**. Remove the shoulder screw **13** from the encoder bracket **12**.
6. Loosen the two set screws of the inner presser collar **14** and the six bolts of the collar **15**, and pull the driving shaft **16** to the left.
7. Remove the three bolts **17** and the head **7**.

Note:

Pull the driving shaft at the position where the zero bight needle location dog **13** and the photo-sensor **19** do not make contact with each other. (They make contact at 80 - 120 degrees.)

[Reassembling the head]

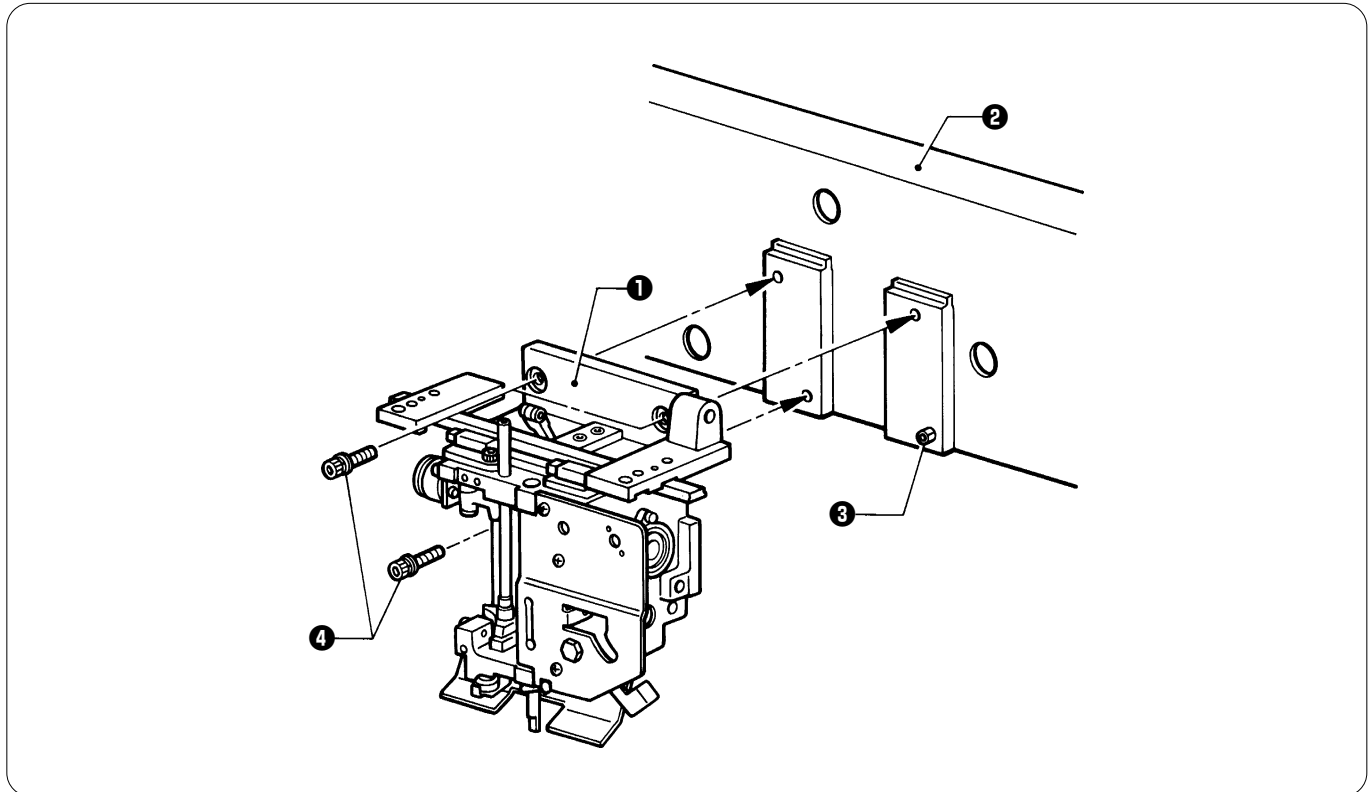

1. Hook the head **1** on the projections of the bridge **2**, make contact with the right side of the head to the spring pin **3**, and attach the head **1** to the bridge **2** with the three bolts **4**.

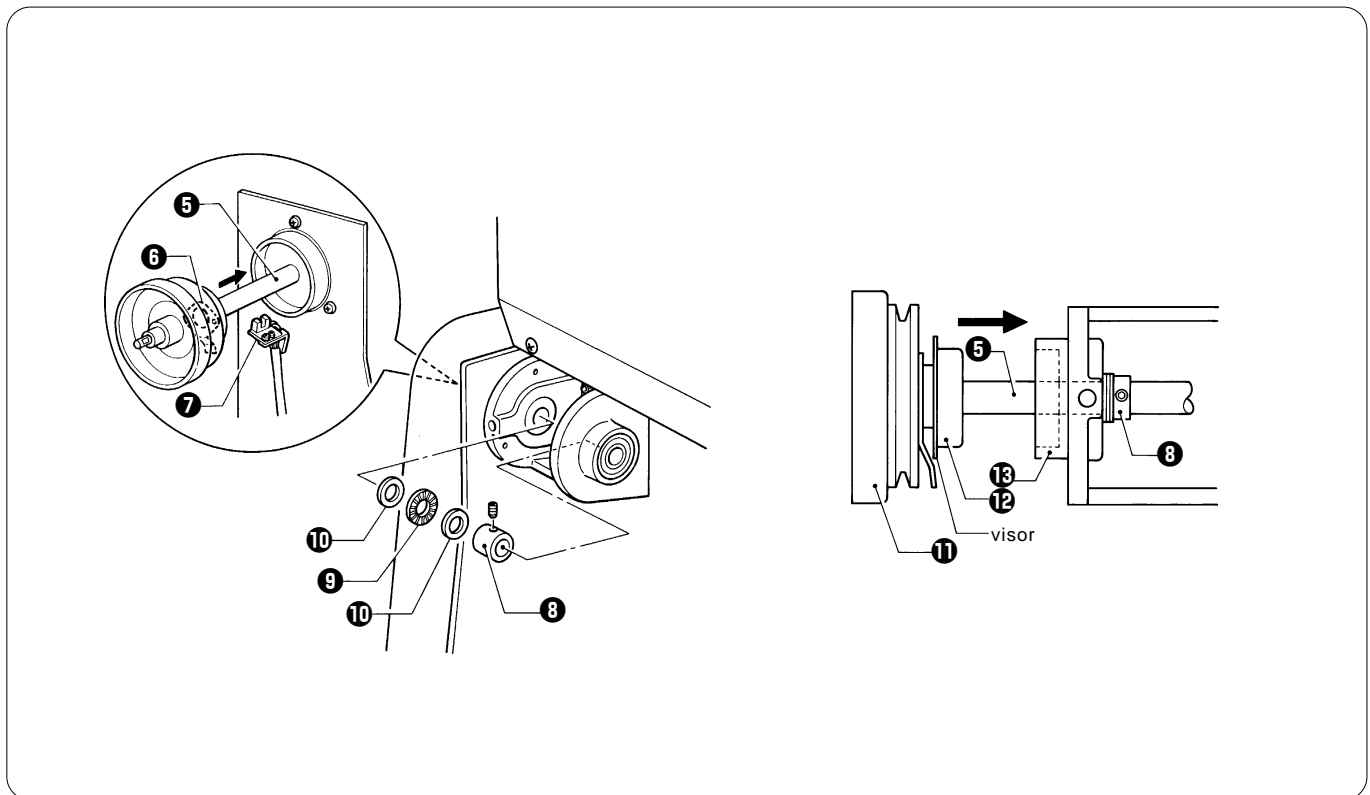

2. As shown in the figure, insert the driving shaft **5** from the left while passing it through the inner presser collar **8**, the thrust roller bearing **9**, and the two thrust washers **10** so that the zero bight needle location dog **6** and the photo-sensor **7** do not make contact with each other. Insert the driving shaft **5** all the way until the visor of the bearing **12** makes contact with the end of the driving shaft bearing **13**.
3. Press pulley B **11** so that it covers the driving shaft bearing **13** with the inner presser collar **8**, and tighten the set screw of the inner presser collar **8** to eliminate end play.

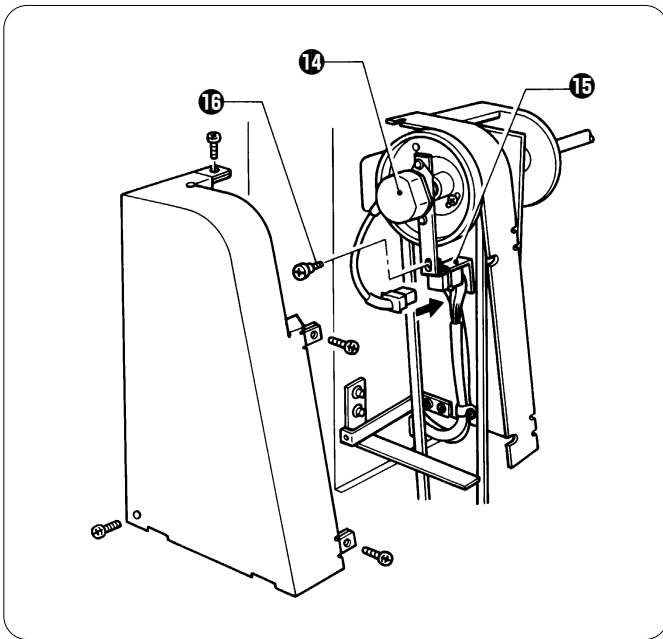

4. Attach the connector of the rotary encoder 14 to the encoder bracket 15 using the shoulder screw 16.

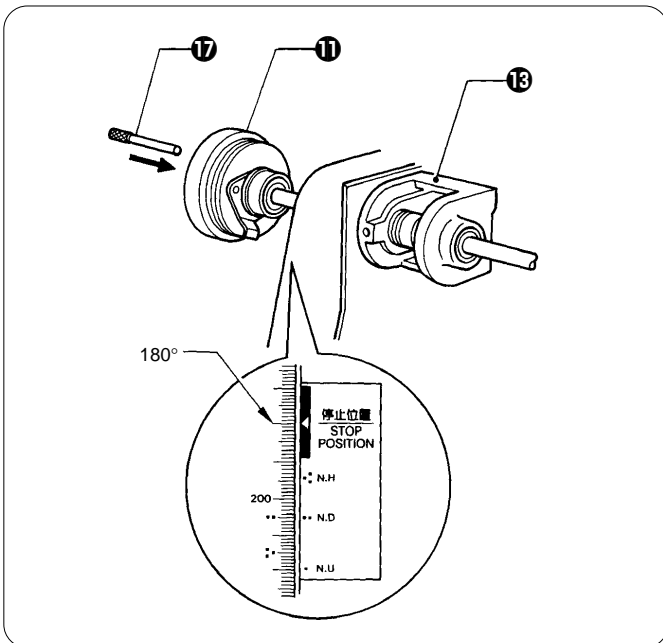

5. Insert the positioning bar 17 into the holes of pulley B 11 and the driving shaft bearing 13 (when the pulley indicator is aligned with 180 degree mark) to secure the driving shaft 5.

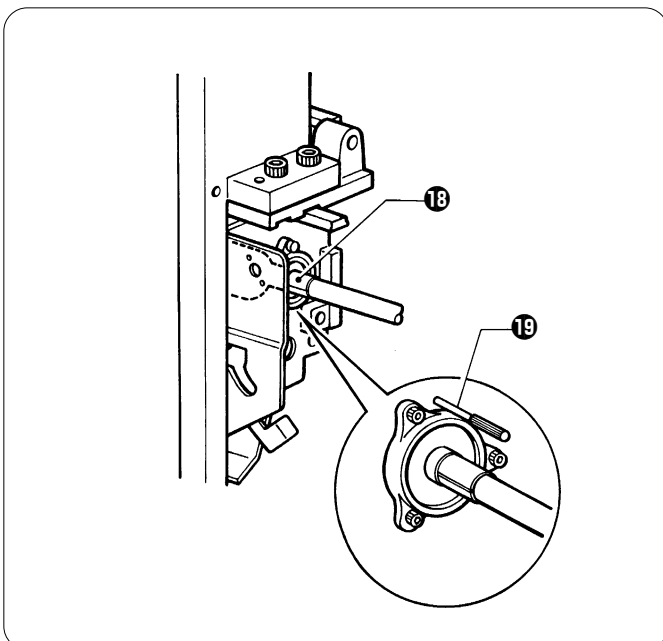

6. Align the hole on the right side of the head with that of the needle bar driving cam 18, and insert the gauge pin 19 into them.

Note:  
Use optional gauge pins.



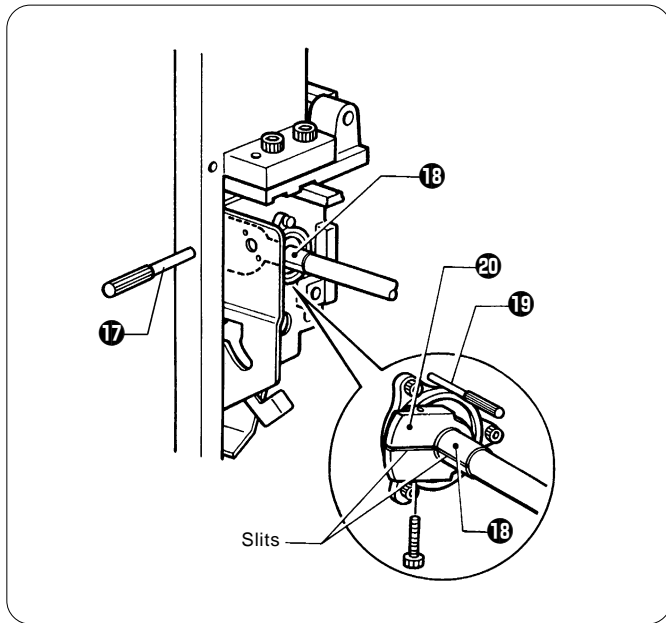

7. Align the slit of the needle bar cam 18 with that of the collar 20, and secure the latter. Repeat this step for all of the six heads. After this step is completed for all heads, remove the gauge pin 19 and the positioning bar 17.

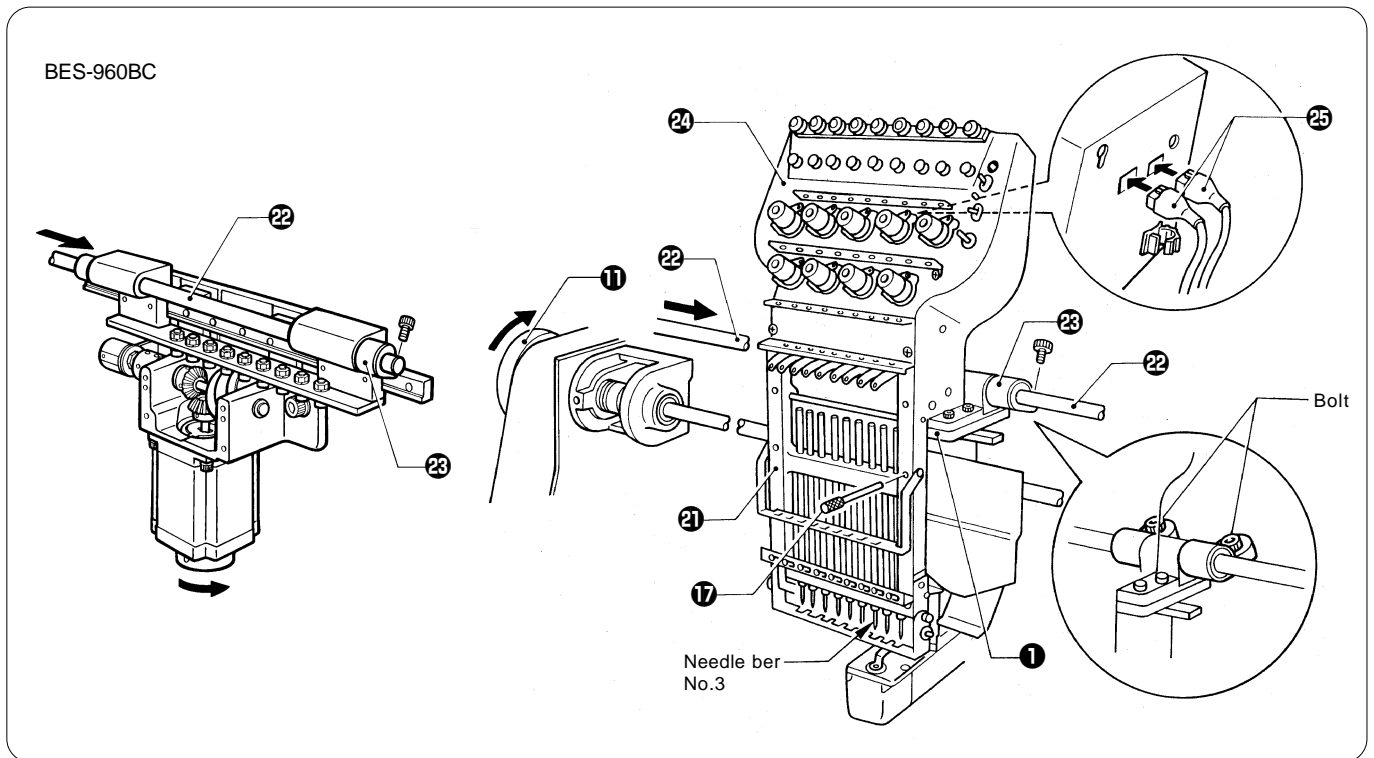

8. Install the needle bar case 21 on the head 1, and insert the connecting shaft 22. Do not forget to pass it through the change bracket collar 23.
9. At needle bar No.3, insert the positioning bar 17 from the front of the needle bar case 21 into the hole of the head 1 to secure the needle bar case 21. Insert another positioning bar 17 into needle bar case of the next head, secure two change bracket collars 23 while checking that the needle definitely falls into the hole on the needle plate attached to the bed.

Notes:

Two positioning bars 17 are required. One is inserted into the head whose needle penetration position has been determined; the other is inserted into the head whose needle penetration position will be determined. (If both bars are used for heads whose needle penetration position is not yet determined, you will not be able to find the correct needle penetration position.) Turn pulley B 11 on each head to make sure that the needle will fall into the hole on the needle plate.

10. Attach covers, and insert two connectors 25 into the rear of the adjustment base 24. At this time, be sure to attach the harnesses to the cord holder, providing an allowance for the harnesses tension between the adjustment base set and the bridge. (If there is no allowance, the pattern to be sewn may be distorted during color change.)

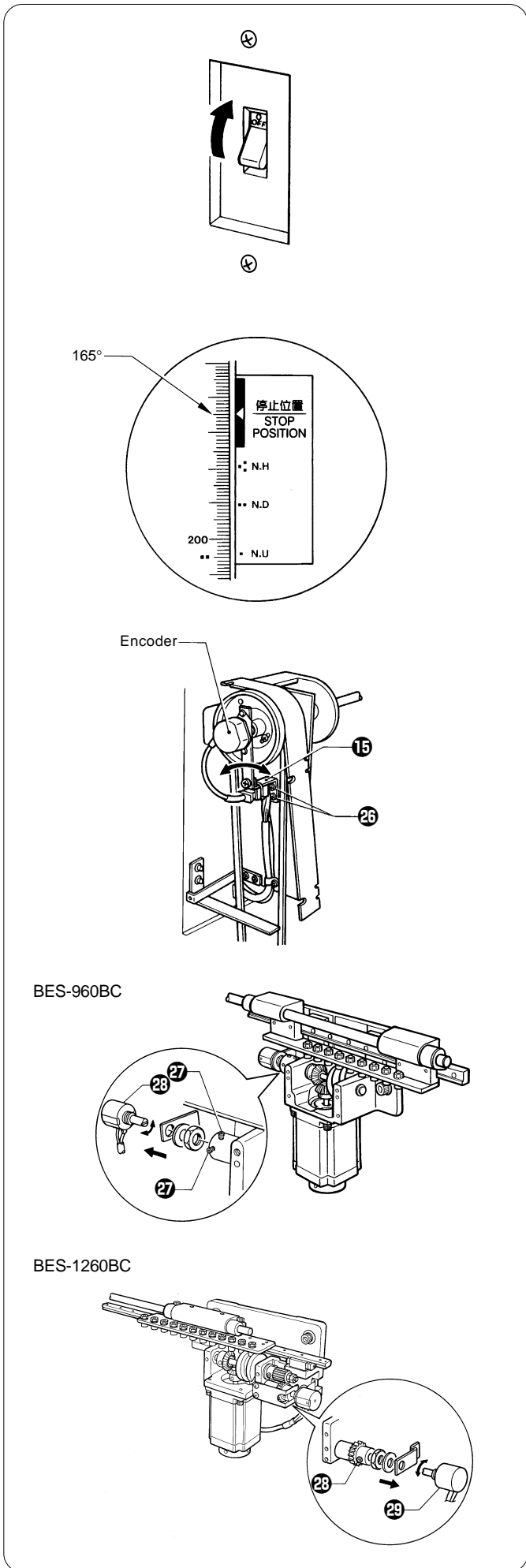

11. Turn on the power of the machine.
12. Press the stop switch and the jog switch (Δ) simultaneously to enter into the test mode.



13. Use the jog switch (▷) to display "Ecd."



14. Press the start switch, and turn the pulley to make sure the buzzer will start to sound at 165 degrees.

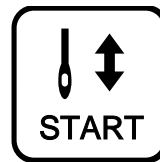

15. If it does not start to sound at 165 degrees, loosen the two screws 26, and adjust the angle of the encoder bracket 15.

16. Press the stop switch once. Keep pressing the jog switch (▷) until "CASE" appears, and press the start switch. Select needle bar no.1 to make sure "19-1" will appear with buzzer sounding. If the buzzer does not sound, loosen the set screws 27, remove the potentiometer 28, and turn the shaft for adjustment.
  - Refer to page 34 when replacing and adjusting the potentiometer.

17. Press the stop switch twice to finish the test mode, and turn off the power of the machine.



## 2. Removing the needle bar case

Refer to page 11, "1. Replacing and adjusting the machine head."

BES-960BC

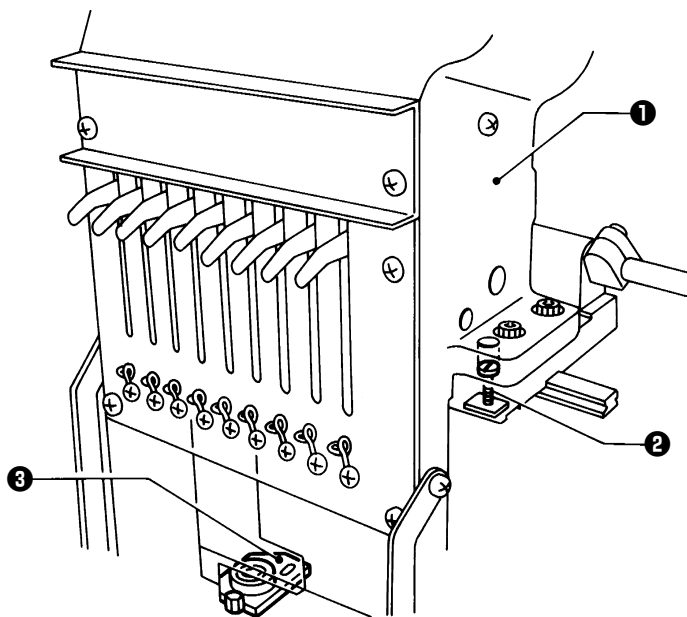

BES-1260BC

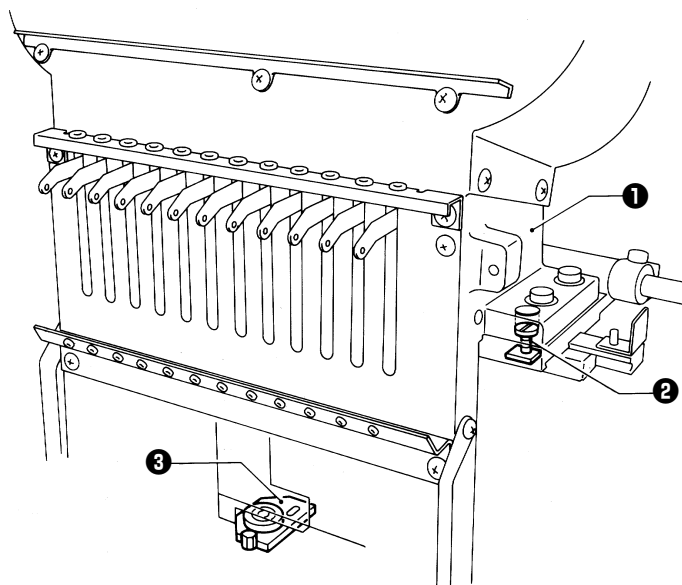

### [Notes on assembly]

- The needle bar case ① should move to the right and left easily, and a needle should be aligned with the hole in the needle plate.
- Loosen the two positioning bars ② for adjusting the needle bar case ① or needle penetration point; adjust the positioning plate ③ for adjusting the inclination.
- Do not loosen the positioning bars ② unnecessarily.

### 3. Replacing and adjusting the thread take-up lever

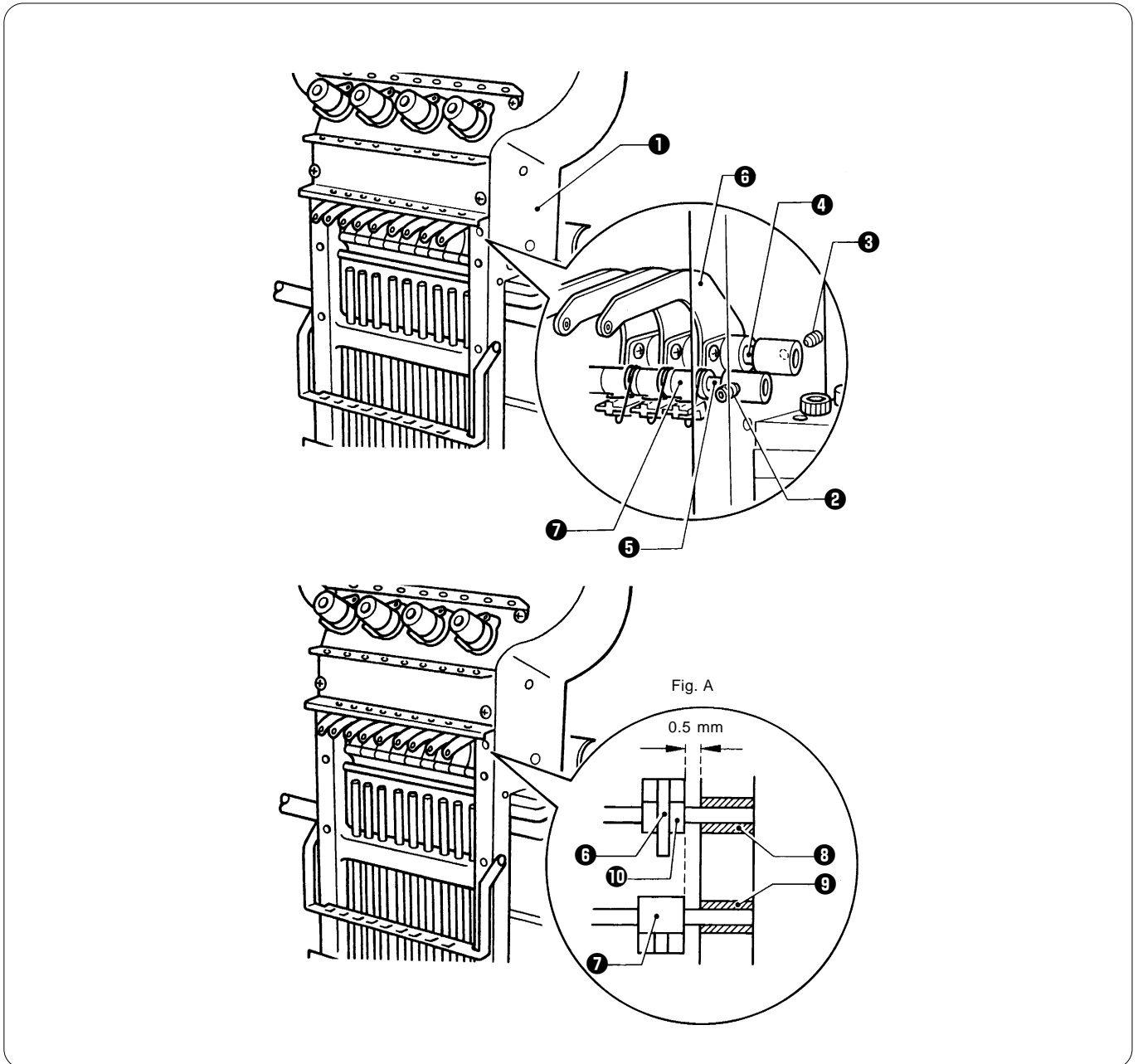

1. Loosen the set screws **2** on the right and left of the needle bar case **1** when viewed from the front, and the set screws **3** on both sides of the rear of the needle bar case **1**.
2. Move the thread take-up shaft **4** and thread take-up holding shaft **5**, and remove one or two thread take-up holding(s) **7**.
  - After replacing the thread take-up lever, reverse the above procedure for re-assembly.

#### [Notes on re-assembly]

- When attaching the thread take-up lever **6** and the thread take-up holding **7**, provide a 0.5 mm clearance from the end of the thread take-up holding **7** to both the thread take-up shaft bush **8** and the thread take-up holding bush **9**. The positions of the thread take-up lever **6** and the thread take-up holding **7** should be as shown in figure A; the thread take-up holding **7** should be inserted into the thread take-up boss **10** without touching the thread take-up lever **6**.
- When the pulley is at 100 degrees (stop position), the thread take-up lever **6** should be the same height as the others.

## 4. Replacing the needle bar

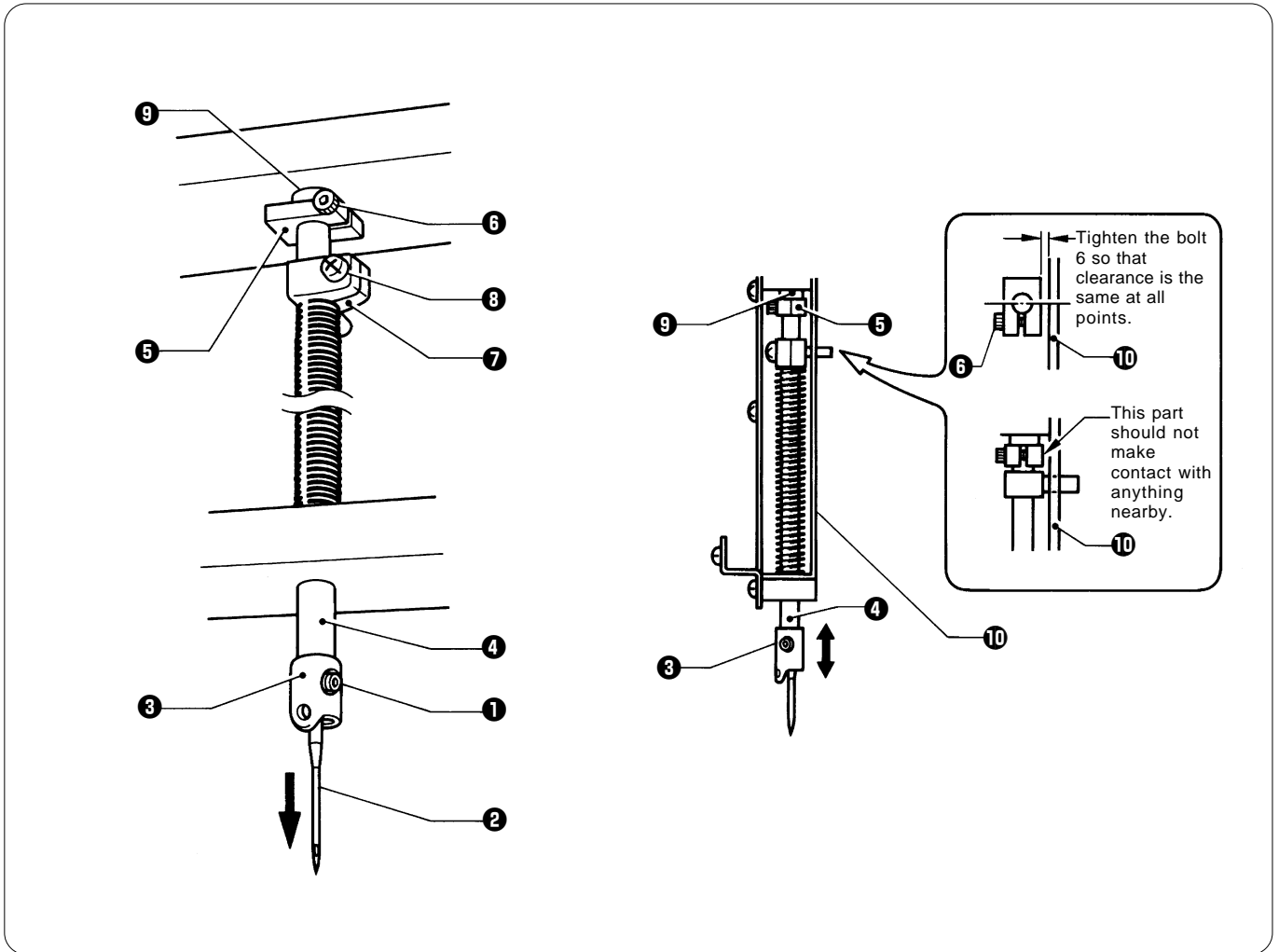

1. Remove the set screw ① and the needle ②.
  2. Remove the needle bar thread guide ③ from the needle bar ④.
  3. Loosen the bolt ⑥ of the top dead center stopper ⑤ and the screw ⑧ of the needle bar clamp ⑦.
  4. Remove the needle bar ④ by pulling it downward. (The cushion rubber, the top dead center stopper, the needle bar clamp, and the spring will come off.)
- After replacing the needle bar, reverse the above procedure for re-assembly.

### [Notes on re-assembly]

- Attach the needle bar thread guide ③ with its hole facing the front.
- Adjust bottom dead center using the bottom dead center gauge.
- Adjust the top dead center stopper by pressing it against the cushion rubber ⑨ at top dead center when the jump bracket and the needle bar clamp are securely fixed in position (when the "■" mark on the pulley is aligned with the one on the belt cover), and pressing the needle bar clamp downward.  
Make sure that the top dead center stopper does not make contact with the needle bar guide rail ⑩.
- When tightening the bolt ⑥ of the top dead center stopper, use the accessory wrench, insert the longer side of the wrench into the bolt head, and tighten it (Tightening torque: 8 kg•cm).

#### Note:

- If the bolt is tightened too much, the needle bar may be sluggish.
- After re-assembly, make sure that the needle bar can be retracted to the top dead center when it is pressed down and released.

## 5. Replacing the jump bracket

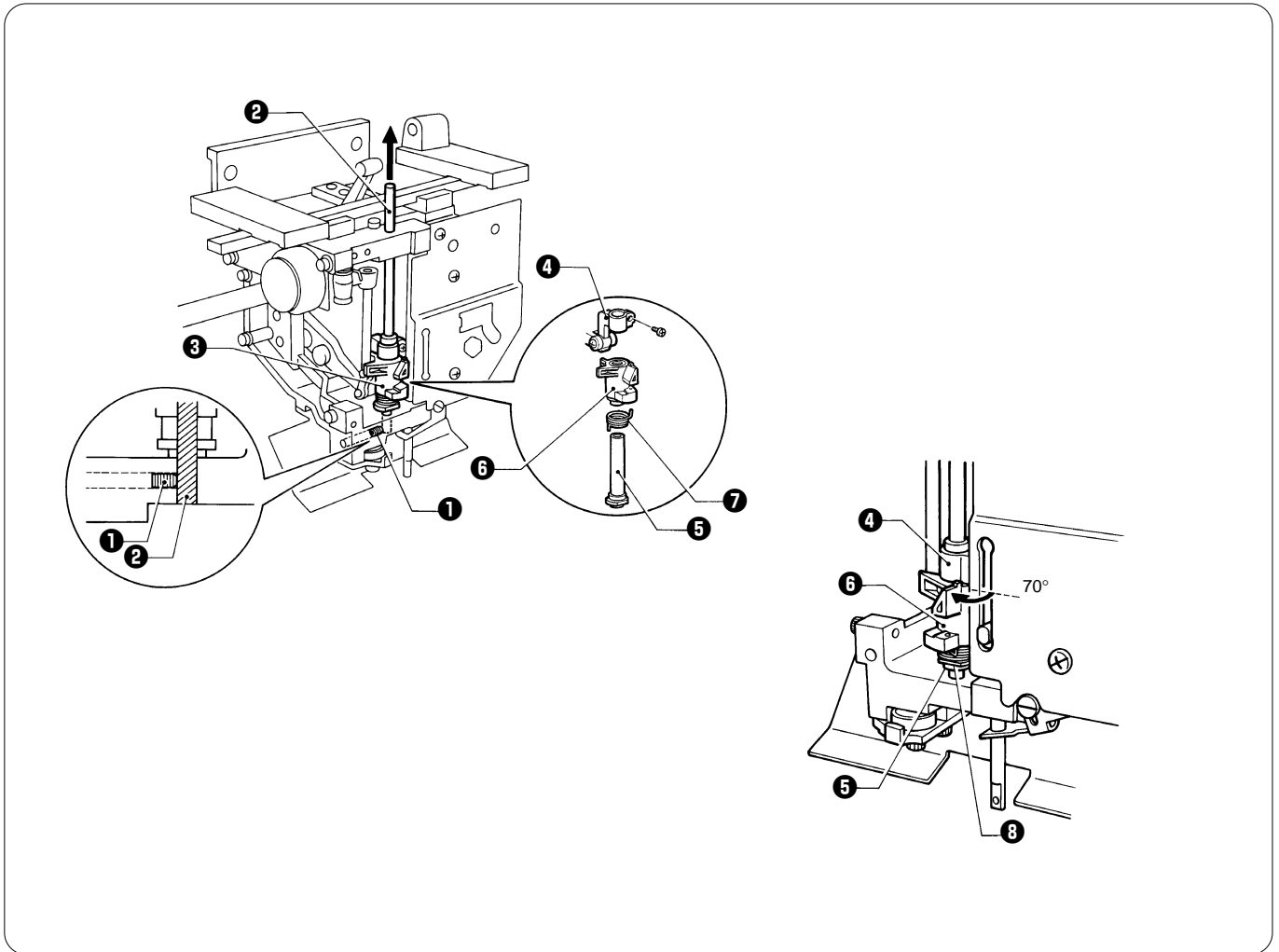

1. Loosen the screw ① on the left of the head.
  2. Remove the base needle bar ② by pulling it from above. (The needle bar vertical set ③ will come off.)
  3. Loosen the screw of the jump clamp ④, and remove the jump clamp ④ and the jump bracket ⑥ from the base needle bar bush ⑤. (The jump spring ⑦ will come off.)
- After replacing the jump bracket, reverse the above procedure for re-assembly.

### [Notes on re-assembly]

- When loosening the screw of the jump bracket ①, pay attention to the position of the base needle bar bush ⑤ (the spring strength). Turn the jump bracket ⑥ 70 degrees from the natural state (where the flat surface ⑧ of the base needle bar bush ⑤ faces the front). Tighten the screw so that the jump bracket ⑥ can be moved easily but have no looseness vertically (it can be moved vertically only 0.03 - 0.05 mm).
- When attaching the base needle bar, align it with the bottom of the head.

## 6. Replacing and adjusting the jump solenoid

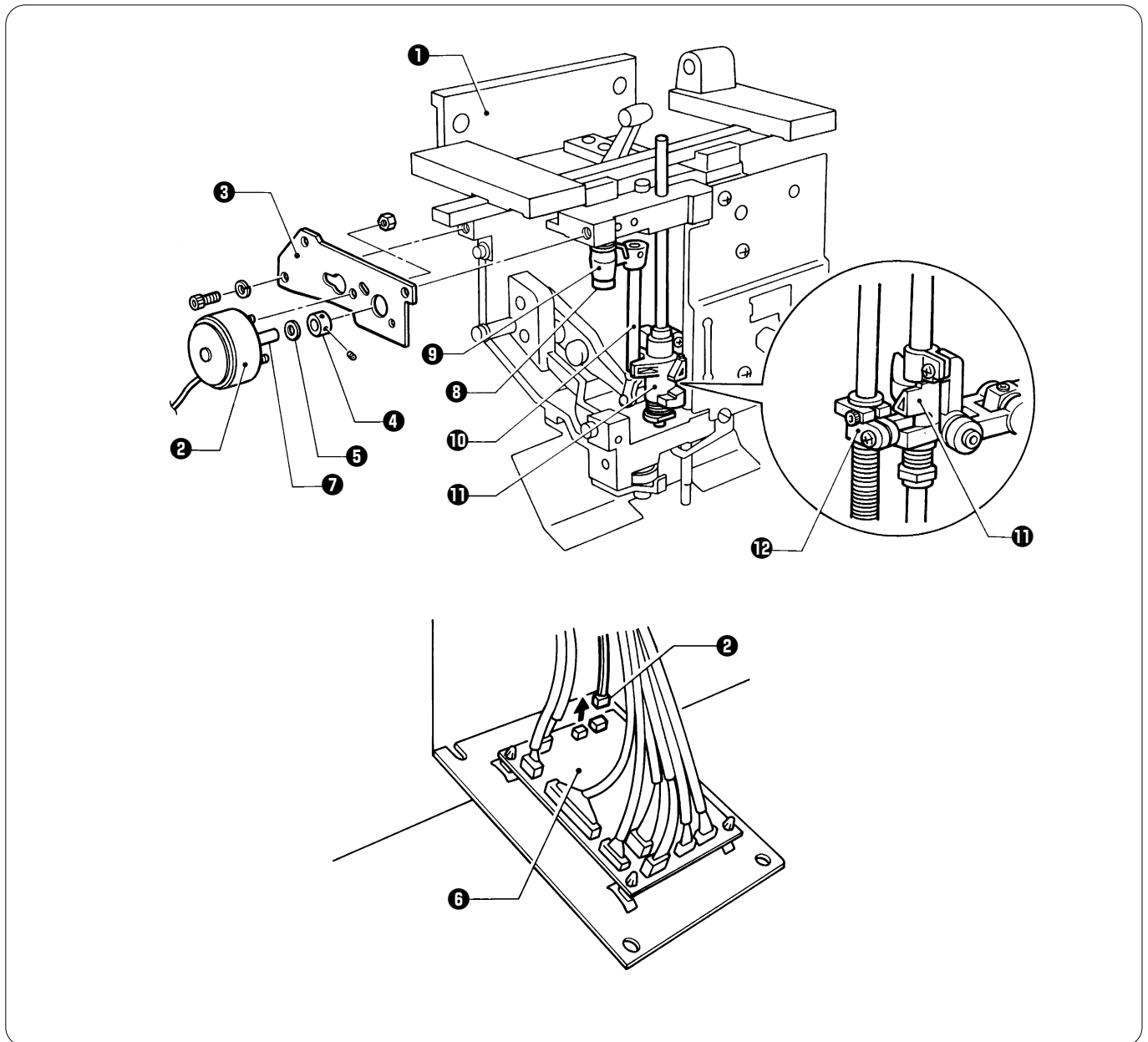

1. Remove the three bolts, and the jump solenoid ② and the jump solenoid base ③ along with the spring washer from the head ①.
2. Loosen the two set screws in the plunger ⑦ of the jump solenoid ②, and remove the set screw collar ④ and the solenoid cushion ⑤.
3. Remove the two nuts, and separate the jump solenoid ② from the jump solenoid base ③.
4. Remove the connector of the jump solenoid ② from the head PCB ⑥.  
After replacing the jump solenoid, reverse the above procedure for re-assembly.

### [Notes on re-assembly]

- With the plunger ⑦ of the jump solenoid ② at the stroke end, adjust the eccentricity of the jump guide shaft ⑧ so that the pipe ⑩ attached to the jump solenoid body assembly ⑨ is at the front.
- Insert the protrusion of the needle bar clamp ⑫ into the recess of the jump bracket ⑪.  
Note:  
Make sure that the protrusion of the needle bar clamp ⑫ is completely inserted.
- With the plunger ⑦ of the jump solenoid ② at the stroke end, make contact with the pipe ⑩ and the jump bracket ⑪.
- When the pipe ⑩ makes contact with the jump bracket ⑪, tighten the set screws of the set screw collar ④ to secure the solenoid cushion ⑤ between the jump solenoid ② and the set screw collar ④.

## 7. Replacing the rotary encoder and the sensor PCB

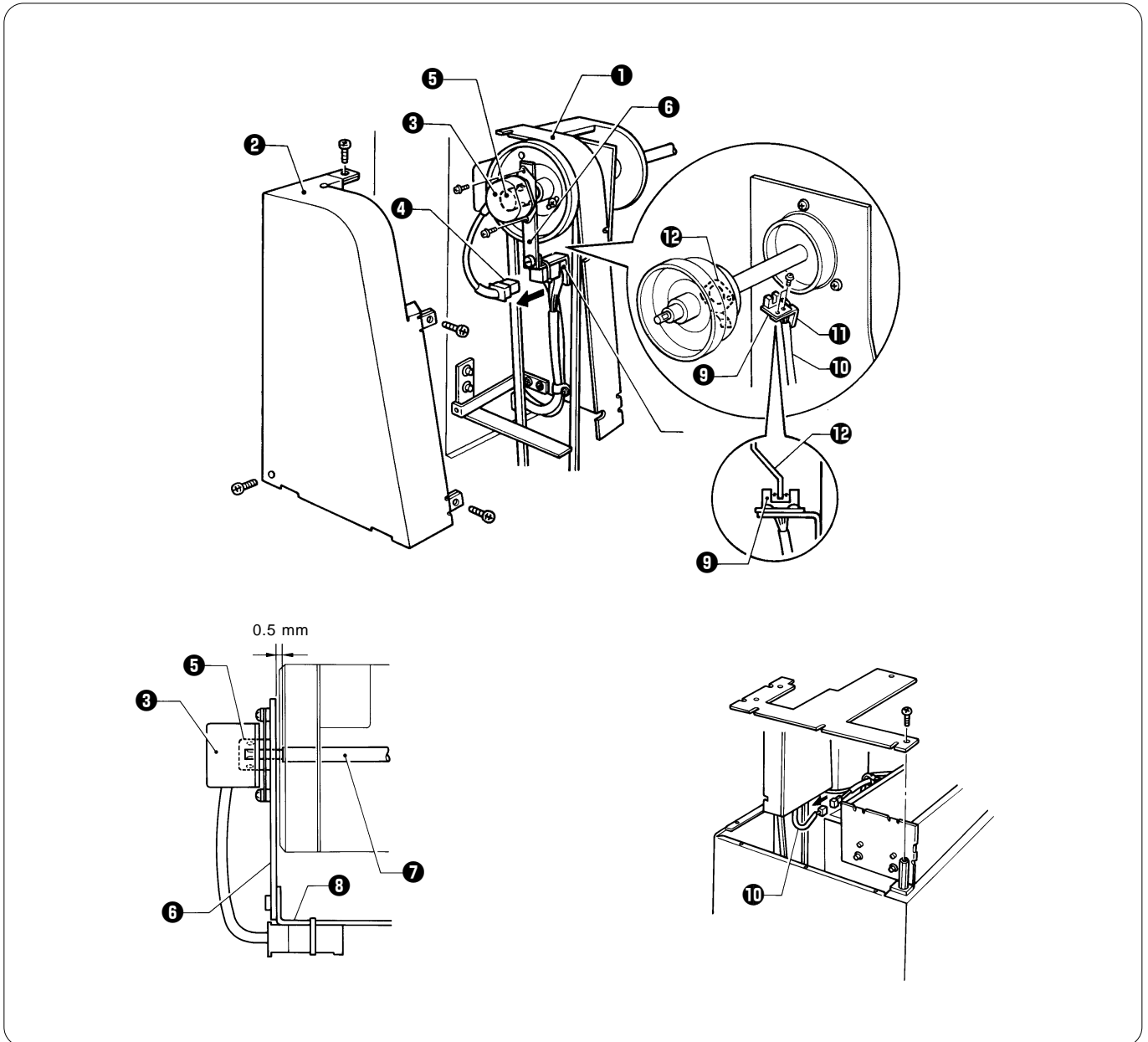

### Replacing the rotary encoder

1. Remove the screws, and belt covers A **1** and B **2**.
  2. Remove the connector **4** of the rotary encoder **3**.
  3. Loosen the two set screws of the rotary shaft **5** attached to the rotary encoder **3**.
  4. Remove the two screws and the rotary encoder **3** from the encoder bracket **6**.
- After replacing the rotary encoder, reverse the above procedure for re-assembly.

### [Notes on re-assembly]

- When reattaching the rotary encoder **3**, tighten the two set screws of the rotary shaft **5** so that they are aligned with the screw flats on the driving shaft.
- Provide an approx. 0.5 mm clearance from the end of the encoder bracket **6** to the end of the driving shaft **7**, and attach the encoder bracket **6** to the encoder adjustment plate **8** so that they make a right angle.
- Adjust the rotary encoder referring to chapter **3** "12-1. Adjusting the machine stop position signal."

### Replacing the sensor PCB

- Remove belt cover B and side cover LB, and separate the connector **10** from the sensor PCB **9**.
- Remove the two screws, and the sensor PCB **9** from the needle position sensor set plate **11**.
- After replacing the sensor PCB, reverse the above procedure for re-assembly.

### [Note on re-assembly]

Make sure that the zero bight needle location dog **12** is central to the sensor PCB **9**.



## 8. Replacing timing belt X

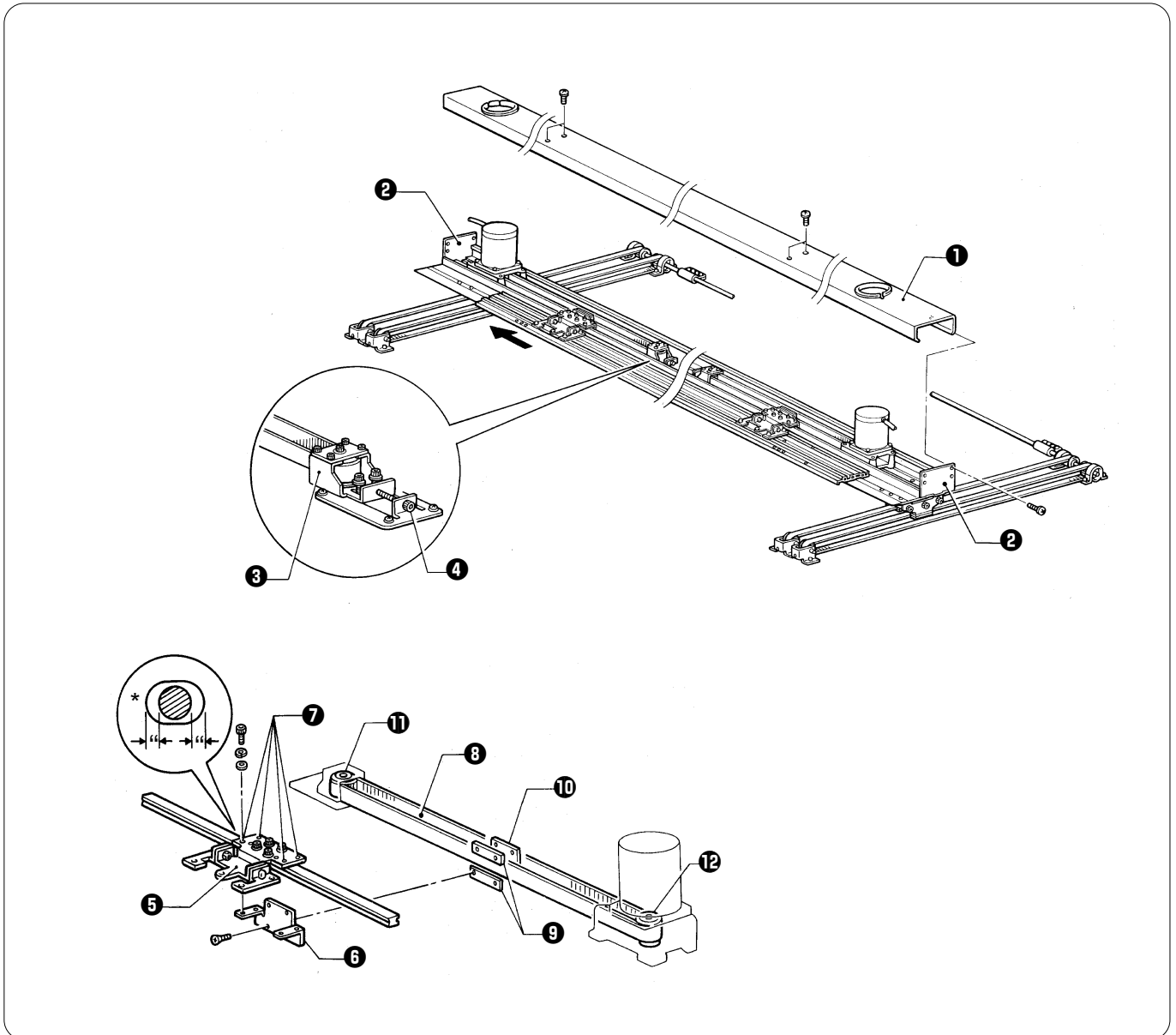

1. Turn off the power.
  2. Remove the screws and the X-feed cover **1** from the X-cover support plates L and R **2**.
  3. Move the X-feed frame all the way to the left.
  4. Loosen the two bolts of X-pulley bracket B **4**, and the screw **4** fully.
  5. Remove the four bolts **7** to separate the X feed bracket **5** and the X belt connection plate **6**.
  6. Remove the four screws from the X belt connection plate **6**. Remove timing belt X **8**, the belt spacers **9**, and the timing belt setting plate **10**.
  7. Cut timing belt X **8** to remove it from timing pulleys A **11** and X **12**.
- After replacing timing belt X, reverse the above procedure for re-assembly.

### [Notes on re-assembly]

- \* Turn on the power to magnetize the two X motors on either side. Attach the X belt connection plate **6** to the X feed bracket **5** using the screws **7** so that each of four bolts can be centered in the hole. (Do not shift bolts either way.)
- With the power turned off, if the weight of the X carriage greatly varies when the connectors of the X pulse motors on both sides are attached or separate, the X pulse motors may be out of phase.
- Reattach the connectors of the X pulse motors, turn on the power, and make the above adjustment again.
- Adjust the belt tension referring to "adjusting the timing belt tension."

## 9. Replacing timing belt Y

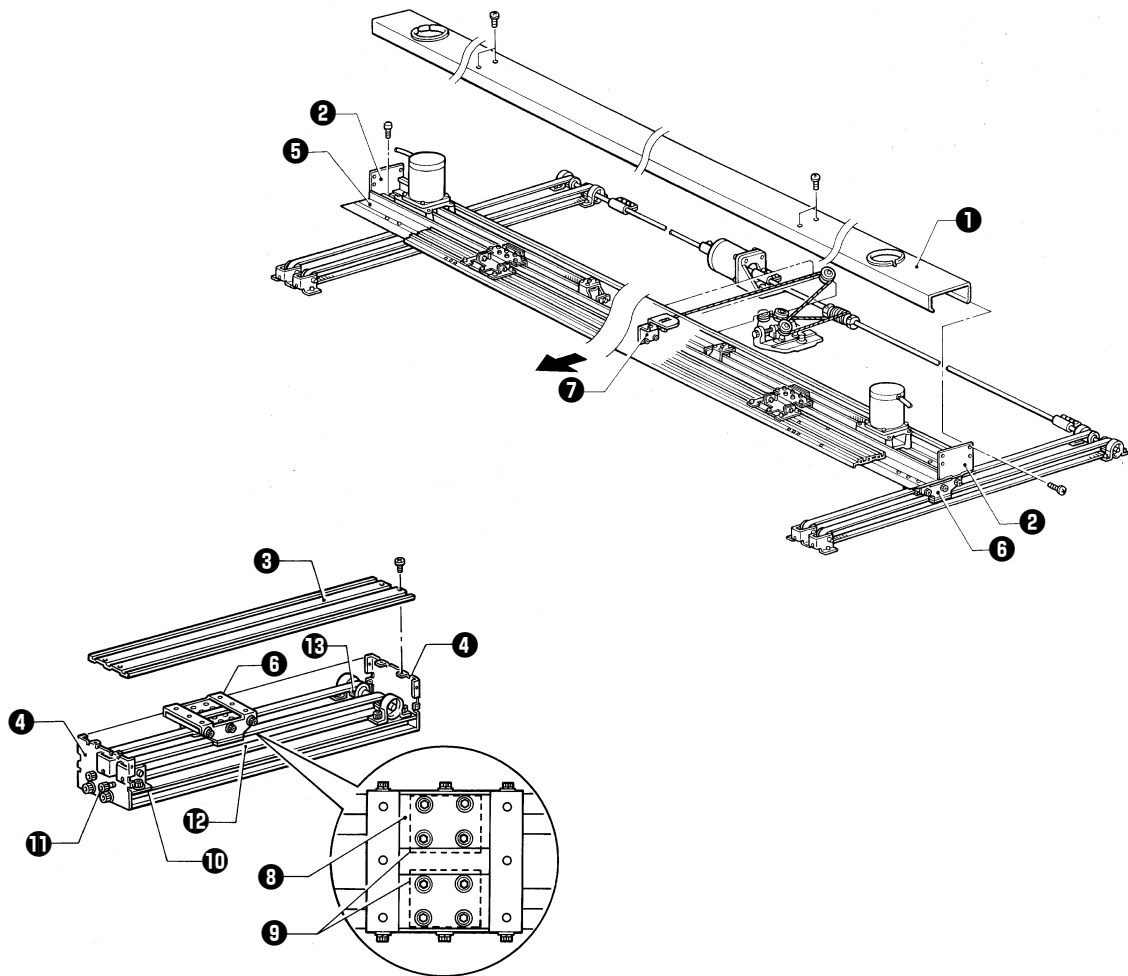

1. Turn off the power.
2. Remove the screws and the X-feed cover **1** from the X-cover support plates L and R **2**.
3. Remove the screws of Y-feed cover U **3** to separate it from the Y-feed cover support plate **4**.
4. Remove the **13** screws of the Y-feed frame **5**. Remove the Y-feed frame **5** from the Y carriage **6** and the rail connecting plate **7**, and shift the Y-feed frame **3** toward the front.
5. From the top of the Y carriage **6**, loosen the bolts of the timing belt setting plate **9** from the holes of the Y carriage base **8**.
6. Loosen the two bolts **11** securing the Y pulley bracket **10** and the bolts securing the Y feed cover support plate **4**.
7. Cut timing belt Y **12** to remove it from timing pulleys A **13** and B.

### Notes:

- When replacing timing belt Y, cut it.
- After replacing timing belt Y, reverse the above procedure for re-assembly.
- Adjust the belt tension before installing the Y-feed frame.
- After replacement, make sure that Y-feed resistance is 15 kgf with the tubular frame on, and 16 kgf with the cap frame attachment on. If the resistance is too great, adjust the Y carriage.

[Notes on re-assembly]

Positioning the Y-feed frame

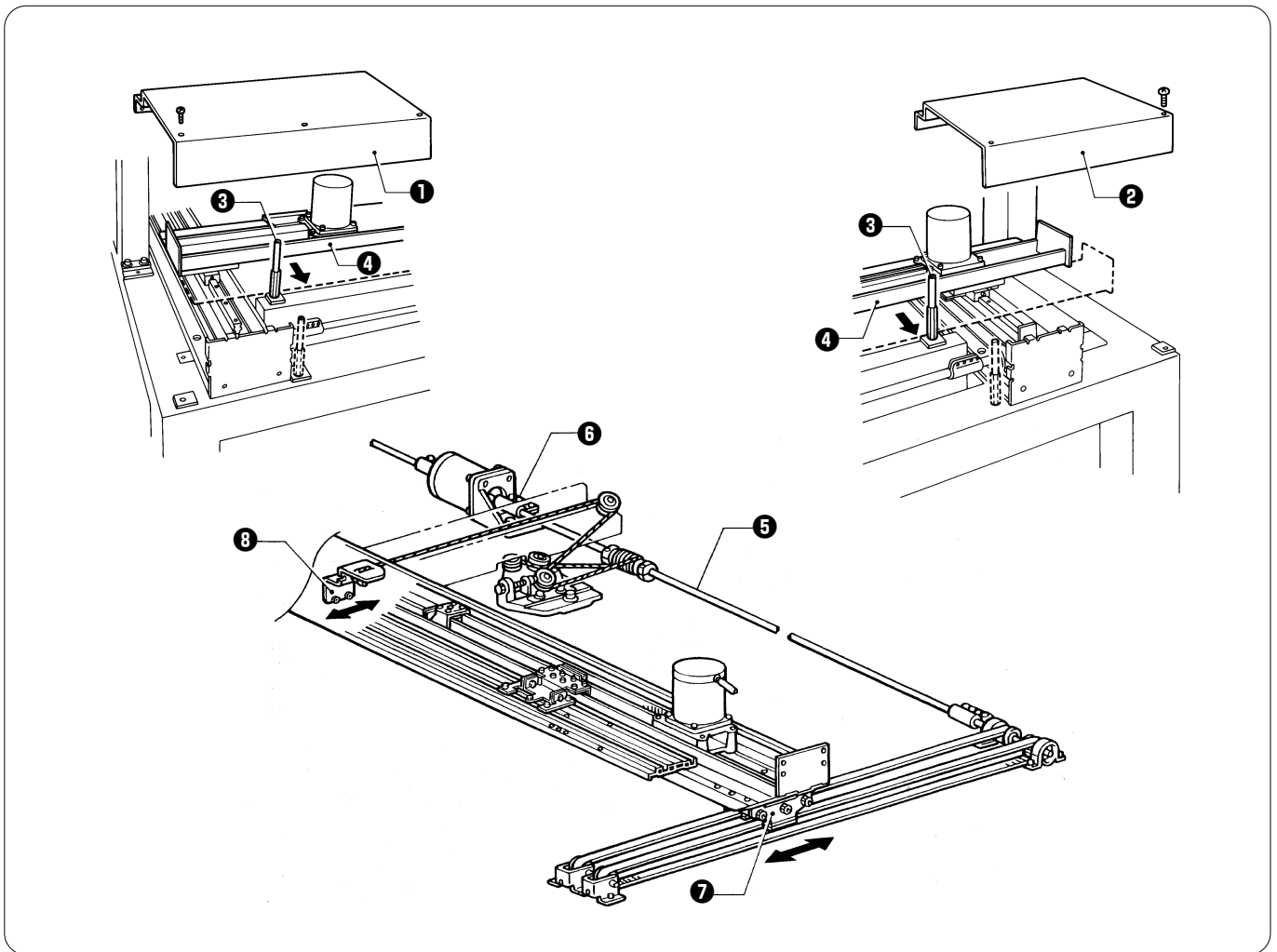

1. Remove table covers L ① and R ②.
2. From the back of the frame, reinsert post LB ③ that is the third from the left, and post LB ③ that is the third from the right, into the extreme left and right holes on the second steel tube, respectively.
3. Press the Y-feed frame ④ against posts LB ③ and secure it using the screws.
4. Return posts LB ③ to their previous positions.

Note:

In step 3., if the screw holes do not match, loosen the bolts of coupling 15. ⑥ connected to the connecting shaft ⑤, move the Y carriage ⑦ or the rail connecting plate ⑧ back and forth to adjust the positions of the screw holes.

## 10. Replacing the driving wire

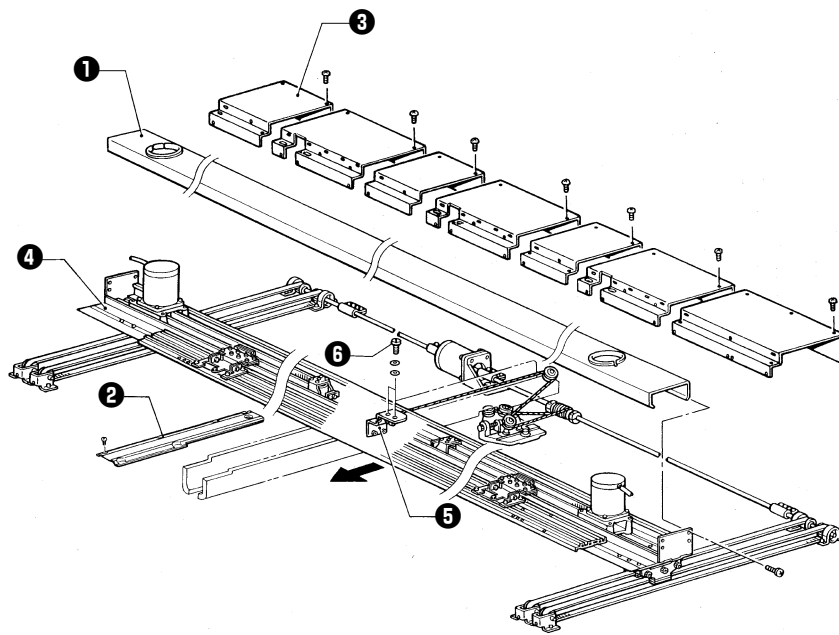

■ Install the driving wire

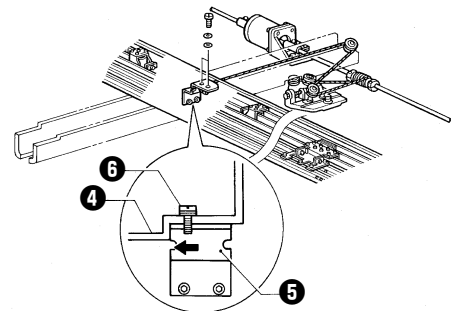
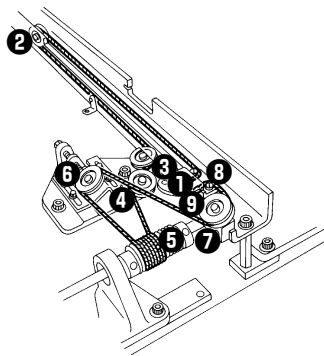
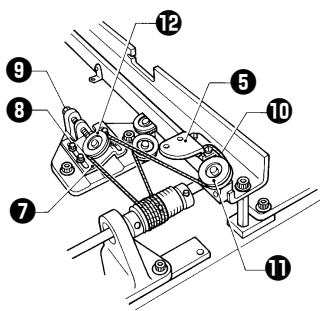

### [Removing the driving wire]

1. Remove the screws, the X-feed cover **1**, bed cover C **2**, and the table cover **3**.
2. Remove the two screws **6** securing the Y-feed frame **4** and the rail connecting plate **5**, and move the Y-feed frame **4** all the way toward the front.

Note:

Perform this step from the rear of the machine.

3. Loosen the four bolts **8** securing the pulley base **7** and the bolt **9**.
4. Remove the driving wire **10** from the rail connecting plate **5**. Remove the pulley **11** and the driving pulley **12**.
5. After replacing the driving wire **10**, reverse the above procedure for re-assembly.

Note:

When attaching the rail connecting plate **5** to the Y-feed frame using the two screws, make the rail connecting plate **5** make contact with the L-shaped portion on the back of the Y-feed frame **4**.

# 11. Replacing and adjusting the presser lifter parts

## 11-1. Presser foot

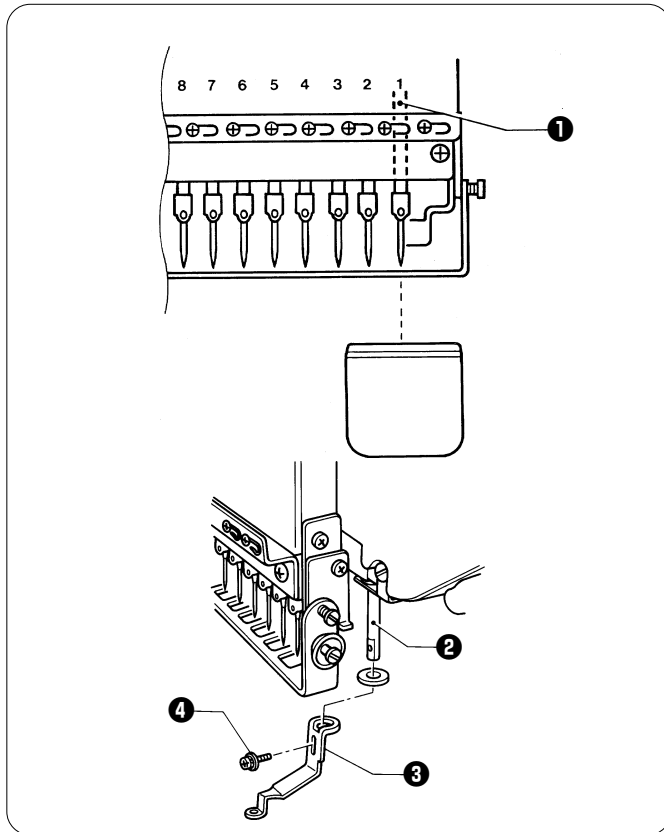

### [Replacing the presser foot]

1. Select needle bar no.1 ①.
  2. Remove the screw, the washer, and the presser foot ③ from the presser foot shaft ②.
- After replacing the presser foot, reverse the above procedure for re-assembly.
  - When attaching the presser foot, align its hole with the needle point. (Loosen the screw ④ to adjust the height of the presser foot ③ at this time.)

## 11-2. Presser foot shaft

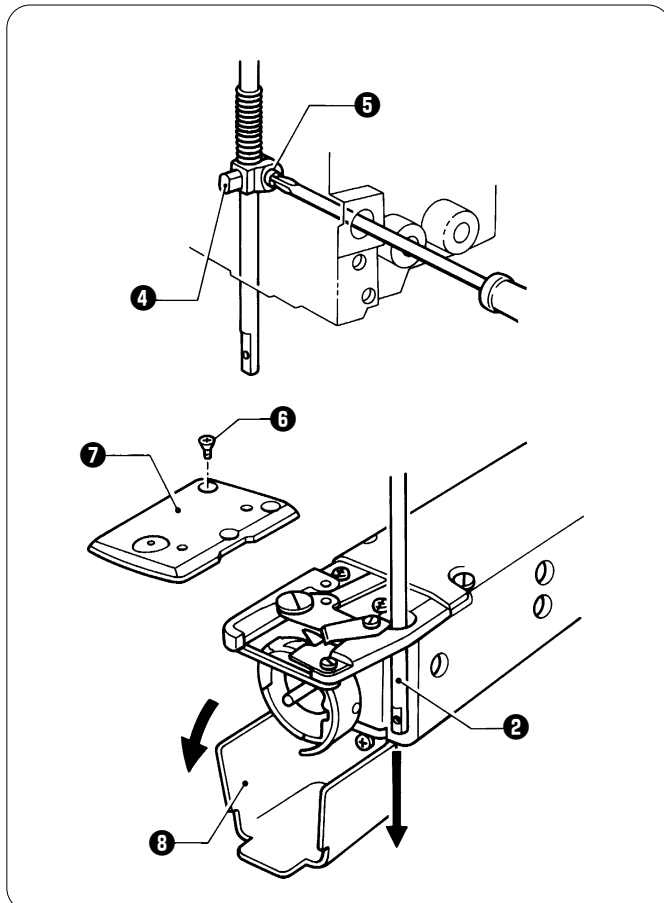

### When the needle bar case is attached

### [Replacing the presser foot shaft]

1. Select needle bar no.1 ①.
  2. Remove the presser foot ③ from the presser foot shaft ②.
  3. Remove the cap on the side of the head, insert a screwdriver into the hole, and loosen the screw ⑤ of the presser foot shaft clamp ④.
  4. Remove the screw ⑥, and the needle plate ⑦.
  5. Open rotary hook cover B ⑧.
- After replacing the presser foot shaft, reverse the above procedure for re-assembly.

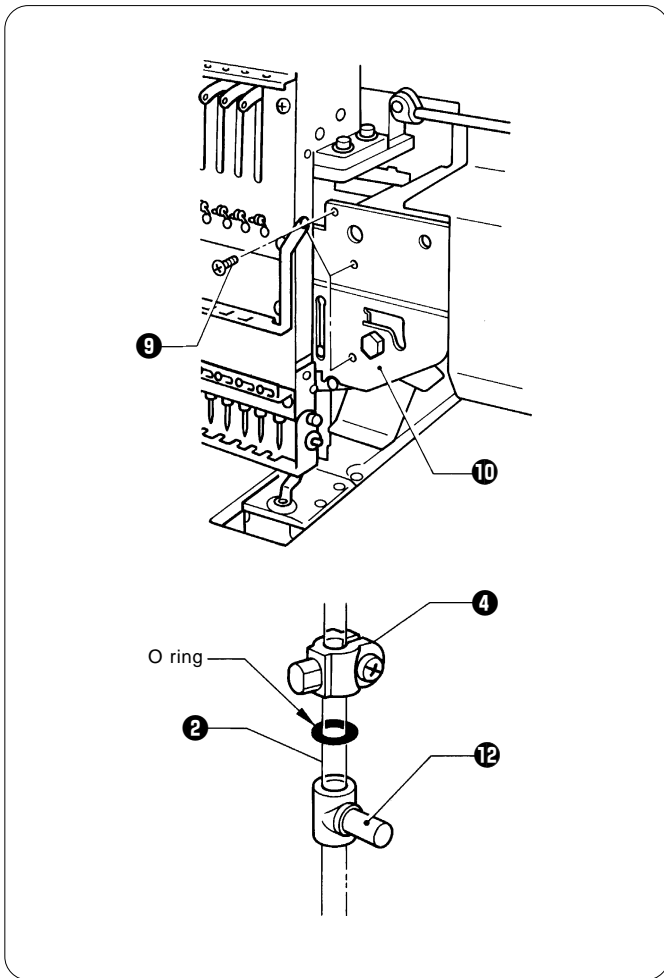

6. Remove the three screws 9, and the presser foot guide plate 10.
7. Remove the presser foot shaft 2 by pulling it downward, and pass it through the hole of the needle plate bracket.
 

Note:

The presser foot shaft can also be removed from above if it can not be removed downward because of being bent. (When removing the presser foot shaft from above, remove the needle bar case.)

When removing the presser foot shaft, the spring may pop out. Be careful.

  - After replacing the presser foot shaft, reverse the above procedure for re-assembly.

**[Notes on re-assembly]**

- The screw of the presser foot shaft clamp 4 should be kept loose.
- Before attaching the presser foot shaft 2, be sure to insert the O ring between the presser shaft clamp 4 and the presser foot operating base 12.

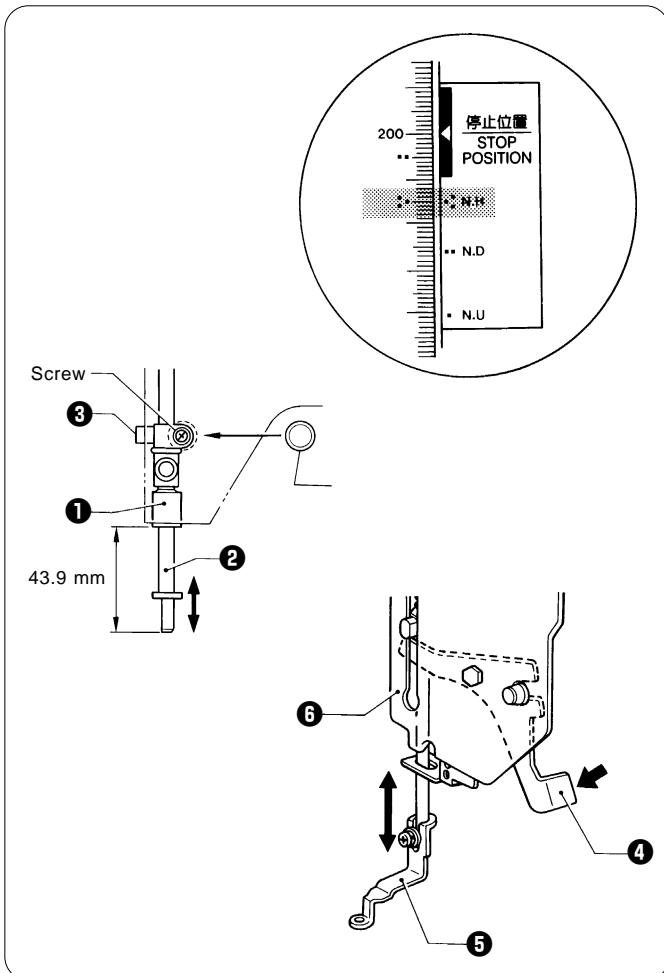

**[Adjusting the presser shaft]**

1. Turn the pulley until the "■" mark on the pulley is aligned with that on the cover.
2. Move the presser shaft 2 vertically so that the distance from the end of presser foot shaft bush D 1 to the presser foot shaft 2 is 43.9 mm.
3. Securely tighten the screw of the presser foot shaft clamp 3.
4. After replacing and adjusting the presser shaft, make sure that the presser foot 5 rises and lowers smoothly by moving it manually using the W retracting lever 4.
 

Note:

If the presser foot has stopped halfway while rising, the presser foot guide plate 6 may be attached on an angle. When tightening the screw of the presser foot shaft clamp, attach the presser foot to the end of the presser shaft, and align the hole in the needle plate with the center of the hole in the presser foot.

### 11-3. Replacing and adjusting the W retracting lever and the RET motor lever

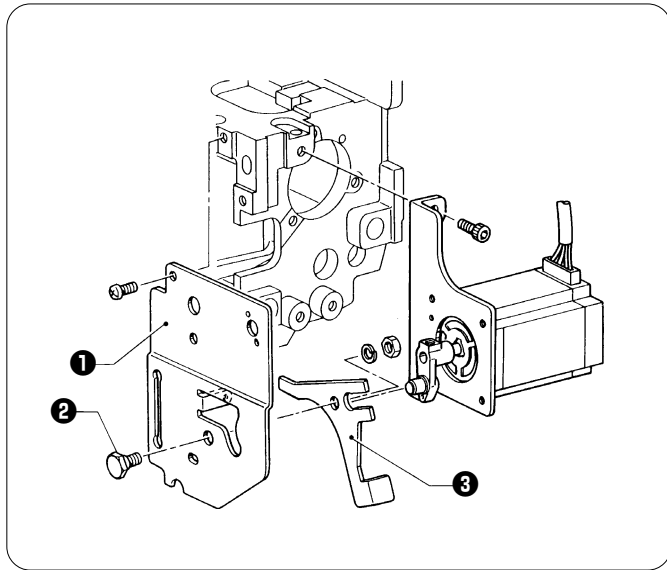

**[Replacing the W retracting lever]**

- Remove the nut of the retracting lever shaft ② from the presser foot guide plate ①. Remove the W retracting lever ③.
- Reverse the above procedure for re-assembly.

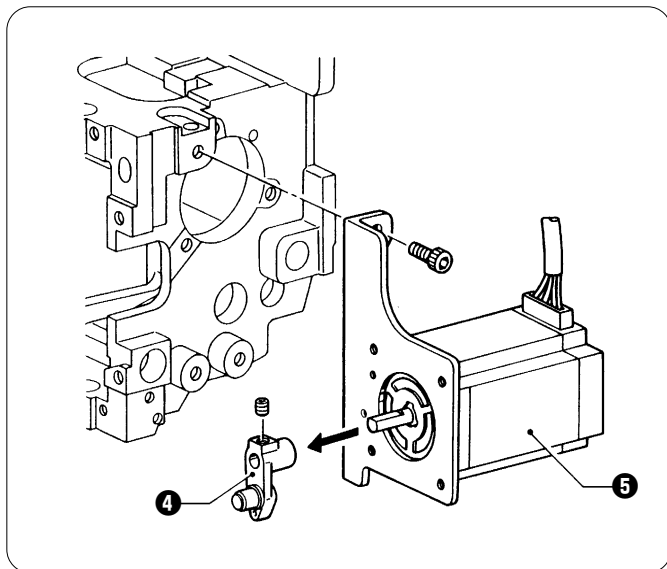

**[Replacing the RET motor lever]**

- Loosen the set screw of the RET motor lever ④, and remove it from the pulse motor ⑤.
- Reverse the above procedure for re-assembly.

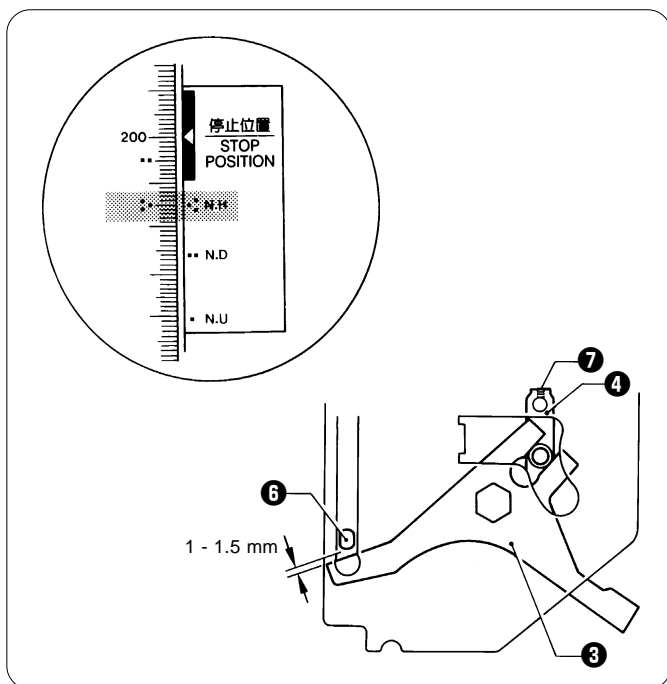

**[Adjustment]**

- Before making this adjustment, turn off the pulse motor ⑤.
  - Turn pulley B until "■" mark on the pulley is aligned with that on the cover.
- At this time, there should be a 1 - 1.5 mm clearance between the W retracting lever ③ and the shaft of the presser foot shaft clamp ⑥. Loosen the screw ⑦ of the RET motor lever ④ to adjust it.

## 11-4. Replacing and adjusting the pulse motor

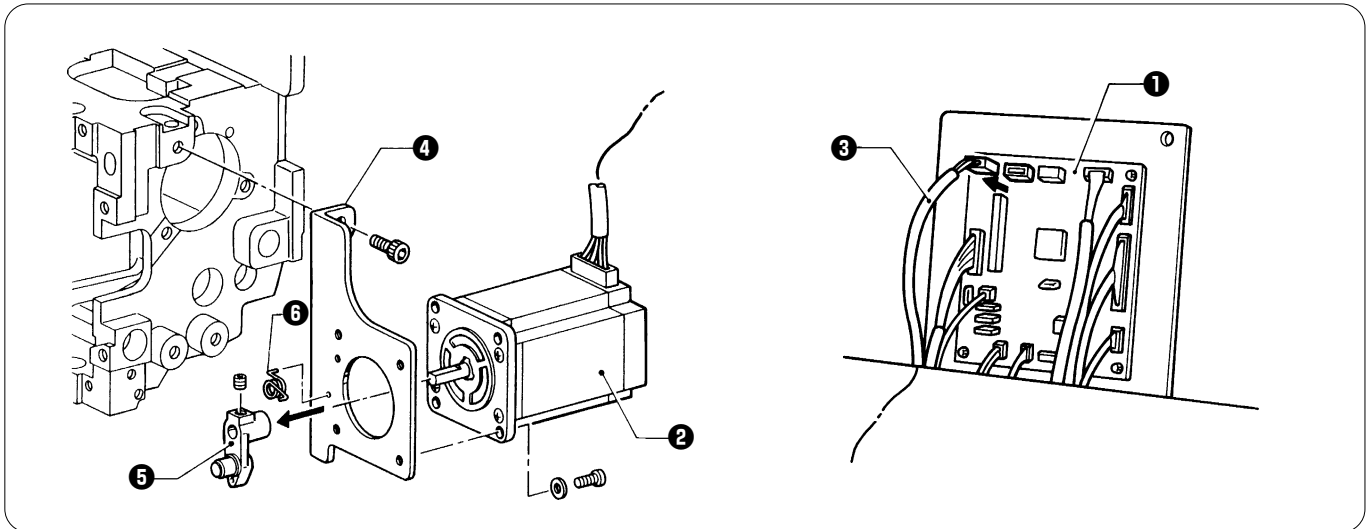

1. Remove the connector ③ of the pulse motor ② from the head PCB ①.
2. Remove the two bolts, and the motor setting plate ④ from the head.
3. Loosen the set screw of the RET motor lever ⑤, and remove it from the pulse motor ②. (At this time, remove the coil spring ⑥.)
4. Remove the four bolts of the motor setting plate ④. Remove the pulse motor ②.
5. After replacing the pulse motor, reverse the above procedure for re-assembly.

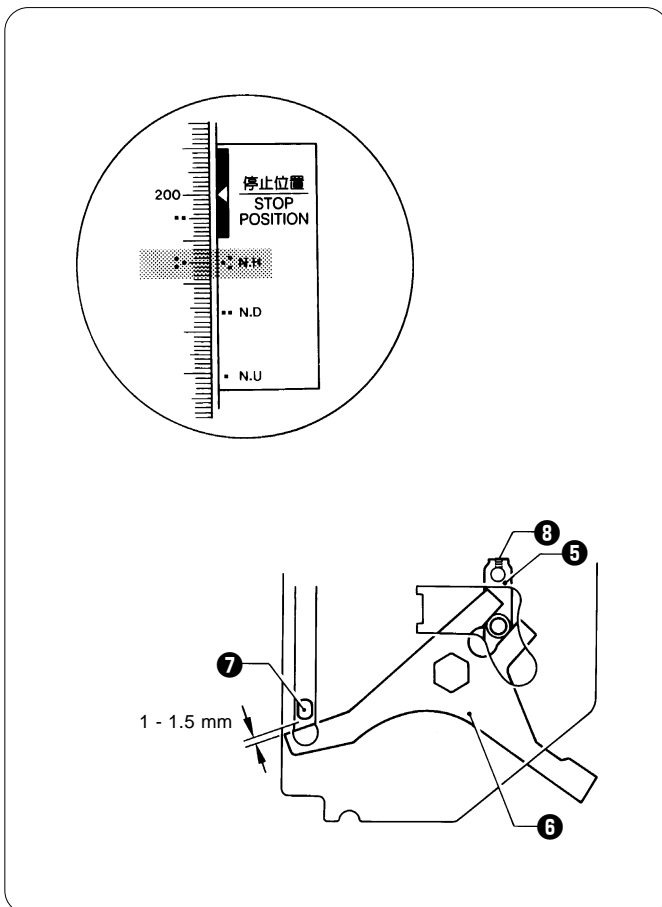

## [Adjustment]

Turn pulley B until "■" mark on the pulley is aligned with that on the cover.

At this time, there should be a 1 - 1.5 mm clearance between the W retracting lever ⑥ and the shaft ⑦ of the presser foot shaft clamp. Loosen the screw ⑧ of the RET motor lever ⑤ to adjust it.



## 12. Replacing and adjusting the gears related to the needle bar flip-up mechanism

BES-960BC

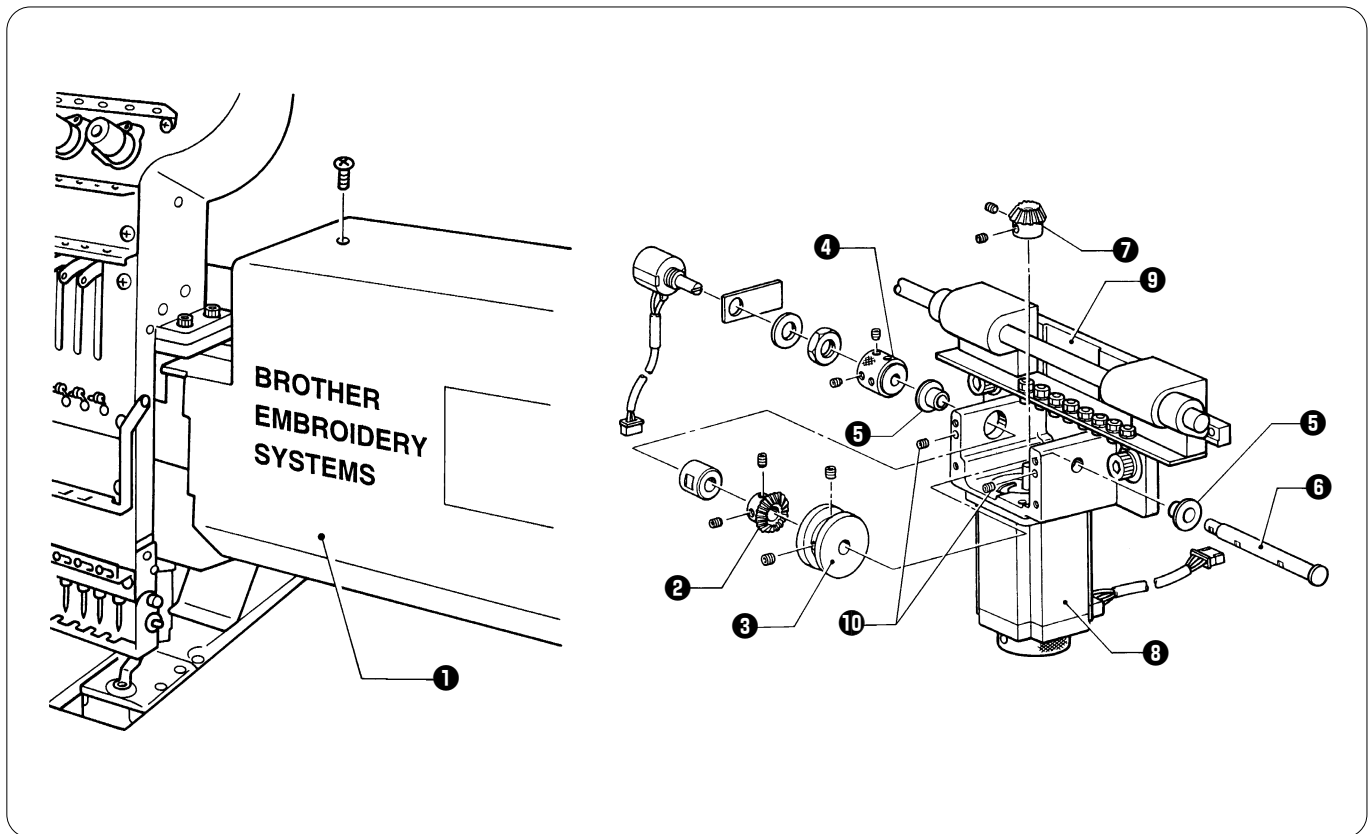

### [Replacing the cam gears]

1. Loosen the screw, and remove the cover ①.
2. Loosen the set screws of bevel gear B ②, the change cam ③, the change box collar ④, and the two flange bushes ⑤, and remove the cam shaft ⑥.
3. Loosen the set screws, and remove bevel gear A ⑦ from the shaft of the pulse motor ⑧.

### [Assembly and adjustment]

1. Fit bevel gear A ⑦ around the shaft of the pulse motor ⑧.
2. When inserting the cam shaft ⑥ into the change box ⑨, place the screw flat of the cam shaft ⑥ so it is on the side. Pass the two flange bushes ⑤, the change cam ③, bevel gear B ②, and the change box collar ④ through the cam shaft ⑥.  
 Note:  
 The change cam ③ should be attached with its straight portion facing the front (toward the needle bar).
3. Place the two flange bushes ⑤ on both sides of the cam shaft ⑥, and tighten the two set screws ⑩.  
 Note:  
 When attaching the change collar ④, either screw hole can be used so long as it is over the screw flat.
4. Align the position of the change cam ③ with needle bar No.3, and tighten the set screws of the change cam ③.
5. Securely tighten all set screws.

BES-1260BC

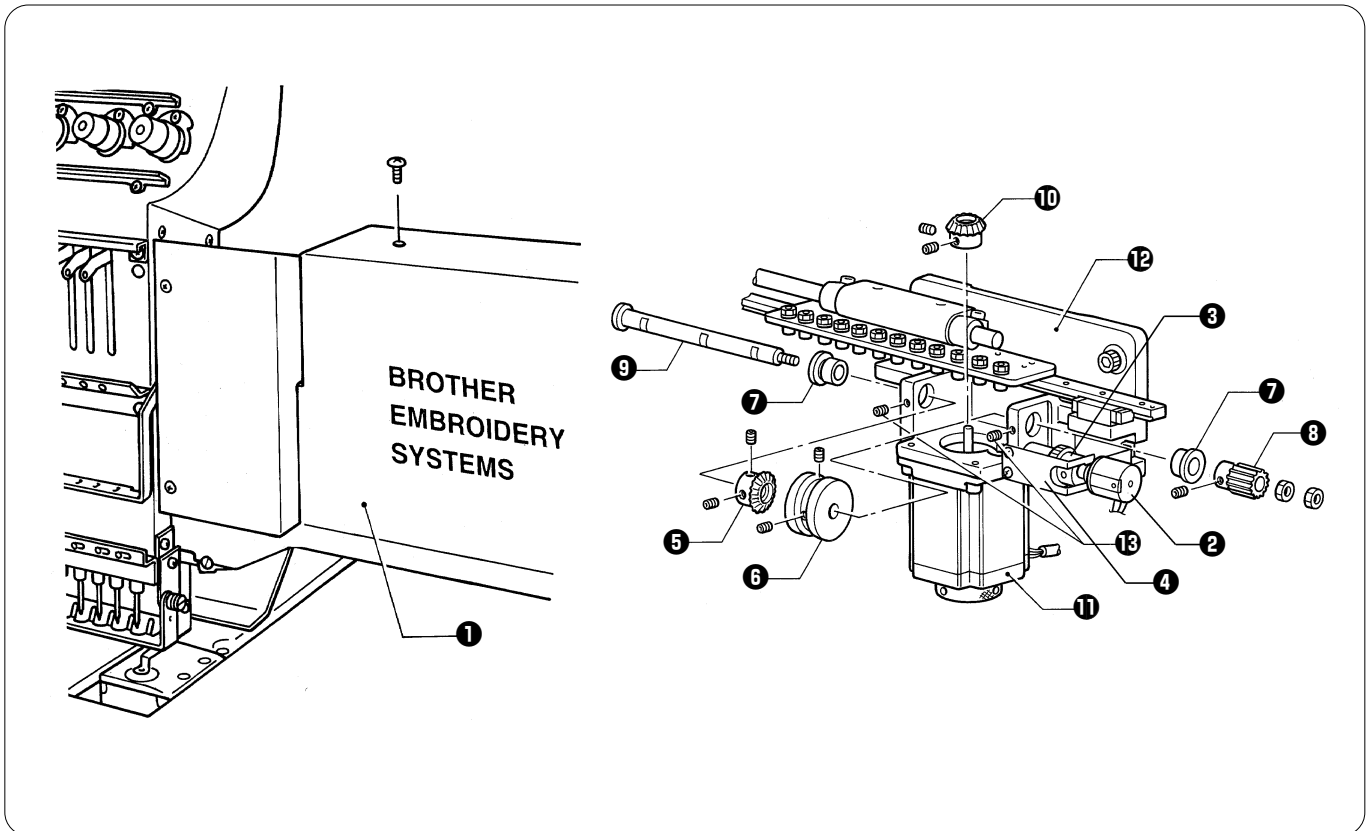

### [Replacing the cam gears]

1. Loosen the screw, and remove the cover ①.
2. Remove the potentiometer ②, reduction gear B ③, and reduction gear plate B ④.
3. Loosen the set screws of bevel gear B ⑤, the change cam ⑥, the two flange bushes ⑦, and reduction gear A ⑧. Remove the two nuts of reduction gear A ⑧, and then the cam shaft ⑨.
4. Loosen the set screws, and remove bevel gear A ⑩ from the shaft of the pulse motor ⑪.

### [Assembly and adjustment]

1. Fit bevel gear A ⑩ around the shaft of the pulse motor ⑪.
2. When inserting the cam shaft ⑨ into the change box ⑫, place the screw flats of the cam shaft ⑨ so they are on the side. Pass the two flange bushes ⑦, the change cam ⑥, bevel gear B ⑤, and reduction gear A ⑧ through the cam shaft ⑨.  
Note:  
The change cam ⑥ should be attached with its straight portion facing the needle bar case.
3. Place the two flange bushes ⑦ on both sides of the cam shaft ⑨, and tighten the two set screws ⑬.
4. Adjust the positions of the cam shaft ⑨ and reduction gear A ⑧ so that they can rotate smoothly without end play.  
Note:  
When attaching reduction gear A ⑧, either screw hole can be used so long as it is over the screw flat.
5. Secure reduction gear A ⑧ using the two nuts.
6. Align the position of the change cam ⑥ with needle bar No.3, and tighten the set screws of the change cam ⑥.
7. Securely tighten all set screws.

## 13. Replacing and adjusting the potentiometer

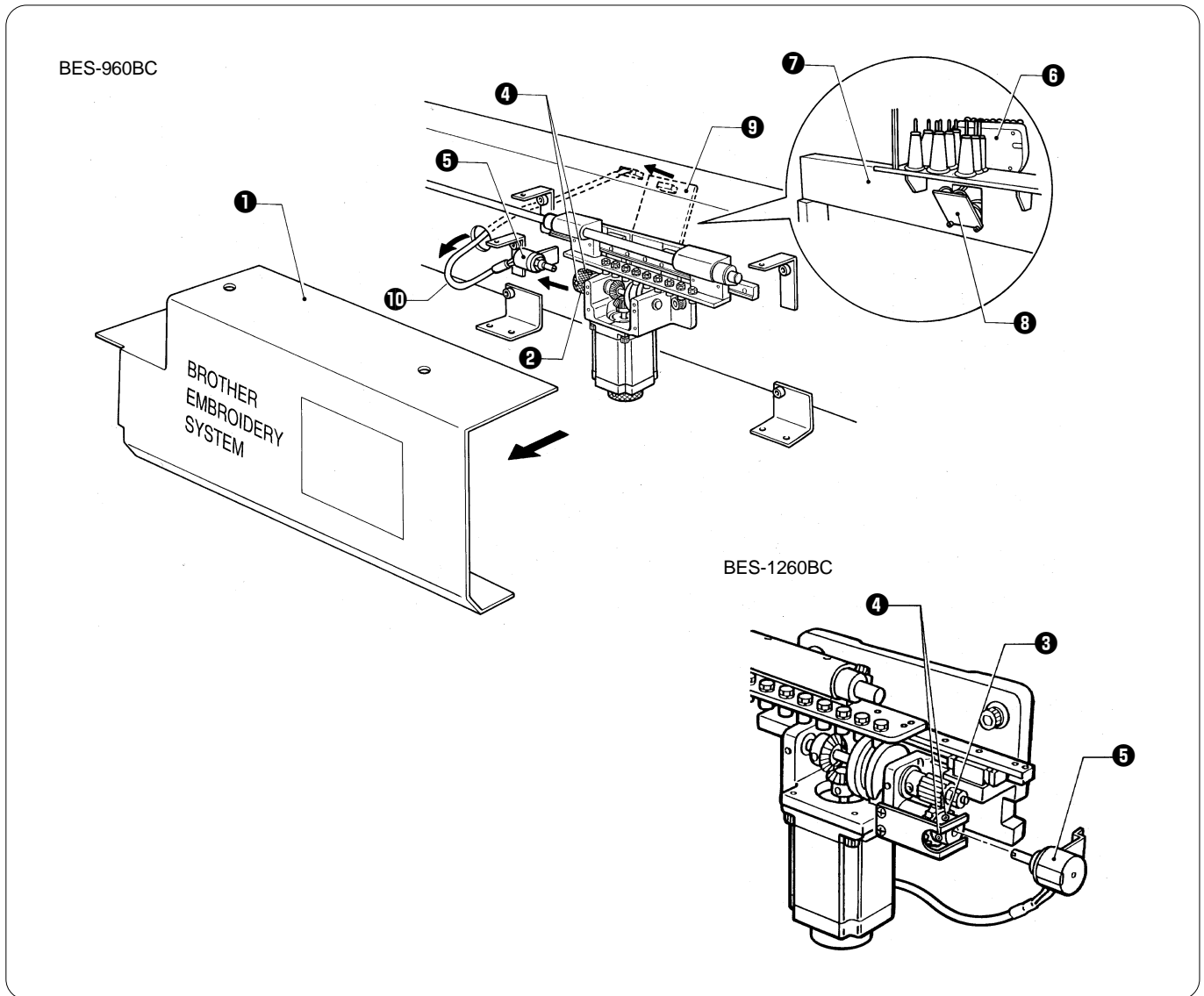

1. Turn off the sewing machine power.
2. Remove the color change cover ① which is attached to the change box at the front-right of the sewing machine.
3. Loosen the set screws ④ of the change collar ② (BES-960BC) or reduction gear ③ (BES-1260BC), and then remove the potentiometer ⑤.
4. Remove the bolts, and then open the bridge cover ⑧ which is at the rear of the bridge ⑦ on machine head No. 1 ⑥, while being careful not to touch the machine head circuit board and harnesses.
5. Gently pull the cable ⑩ of the potentiometer ⑤ which is connected to connector P7 of the machine head circuit board ⑨ to disconnect it from the machine head circuit board ⑨.

BES-960BC

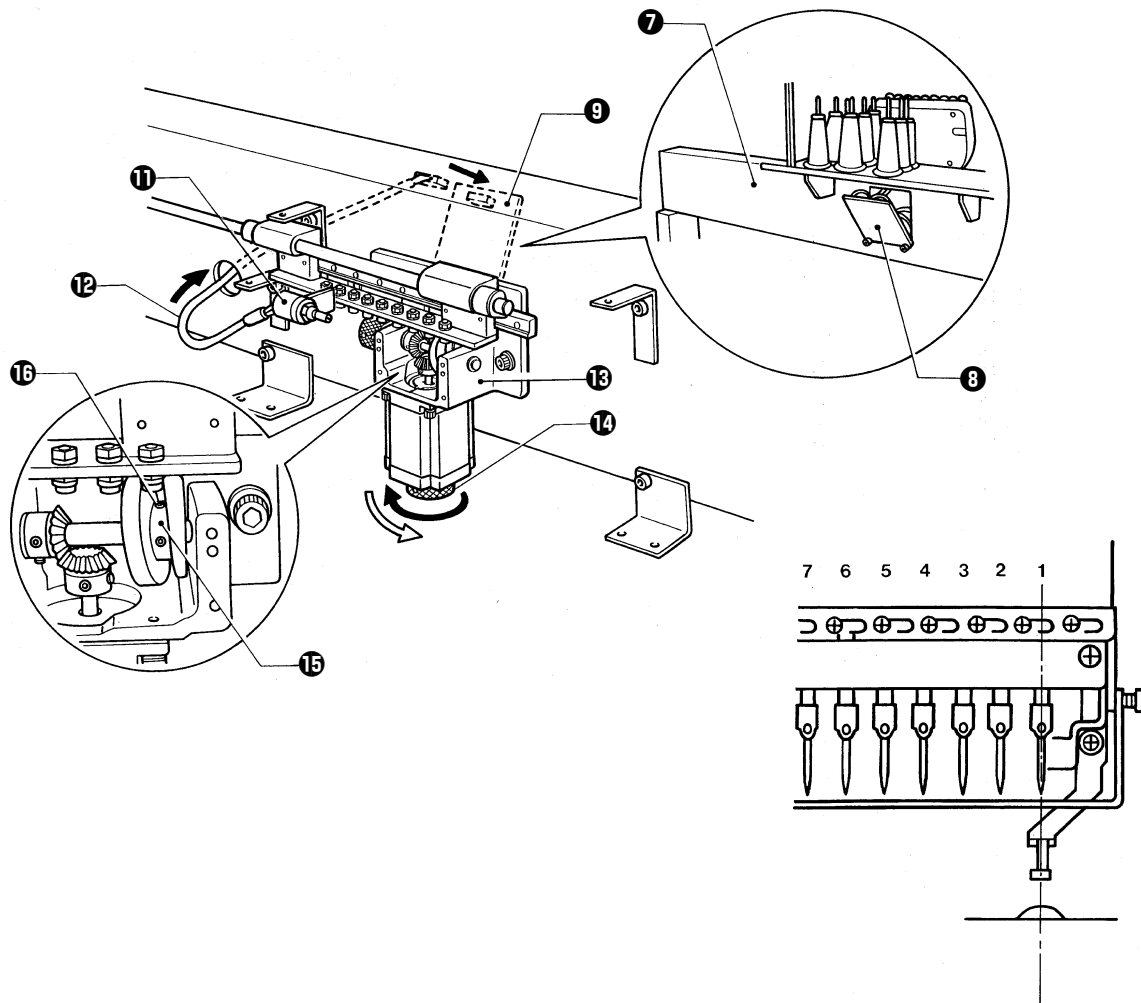

6. Pass the cable 12 for the new potentiometer 11 into the bridge 7 from the change box side, and connect it to connector P7 of the machine head circuit board 9.
7. Install the bridge cover 8 to the bridge 7, while being careful not to touch the machine head circuit board and harnesses.
8. Without the potentiometer 11 installed to the change box 16, press and hold the ( $\Delta$ ) jog key on the operation panel and turn on the power.
9. Turn the knob 14 at the bottom of the change box 16 counterclockwise (when looking from above) as far as it will go, and then turn it about 1/3 of a turn back clockwise so that the set screw 15 on the change cam 15 is facing directly upward.

Note:

Needle bar No. 1 will be at the sewing position at this time.

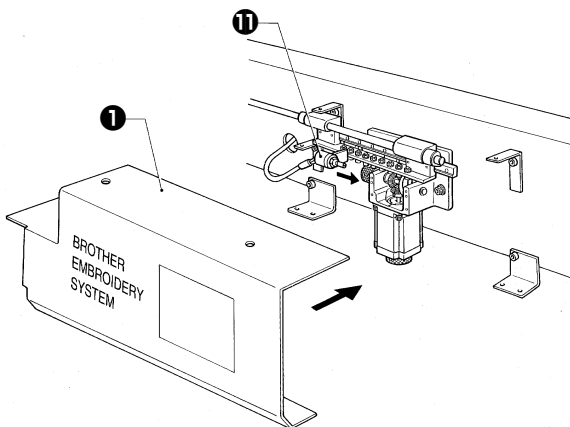
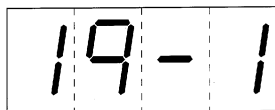
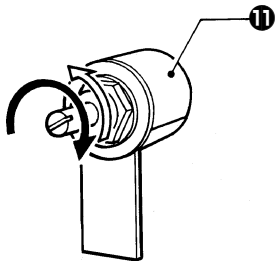
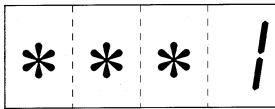
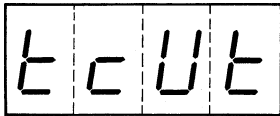

10. Check that there is no error being displayed on the operation panel. Then, while pressing the STOP key, press the (Δ) jog key. "tcut" will then appear on the display.

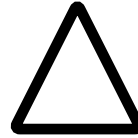

11. Press the (▷) jog key so that "CASE" appears on the display, and then press the START key. The display will now show "xxx1".

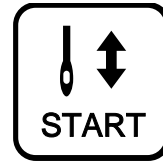
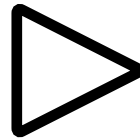

12. Turn the potentiometer ⑪ all the way to the left as shown in the illustration at left. When it is then turned gently to the right, there will be a point where the buzzer on the operation panel sounds.

- The point where the buzzer sounds is the potentiometer ⑪ position for the first stitch. The display will appear as shown in the illustration at left at this time.

13. While the buzzer is sounding, install the potentiometer ⑪ to the change box by following the removal procedure in reverse.

Note:

- Keep checking the buzzer to make sure that the potentiometer ⑪ does not move out of its adjusted position.
- Be careful not to move the needle position which was adjusted in step ⑨ either.

14. Once the potentiometer has been installed, press the needle bar change key on the operation panel to move the needle bar to needles 1 to 9 (BES-960BC) or needles 1 to 12 (BES-1260BC) in order to check the operation.

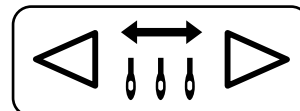

15. After carrying out the above checking operation, install the color change cover ①.

## 14. Replacing and adjusting the movable and fixed knives

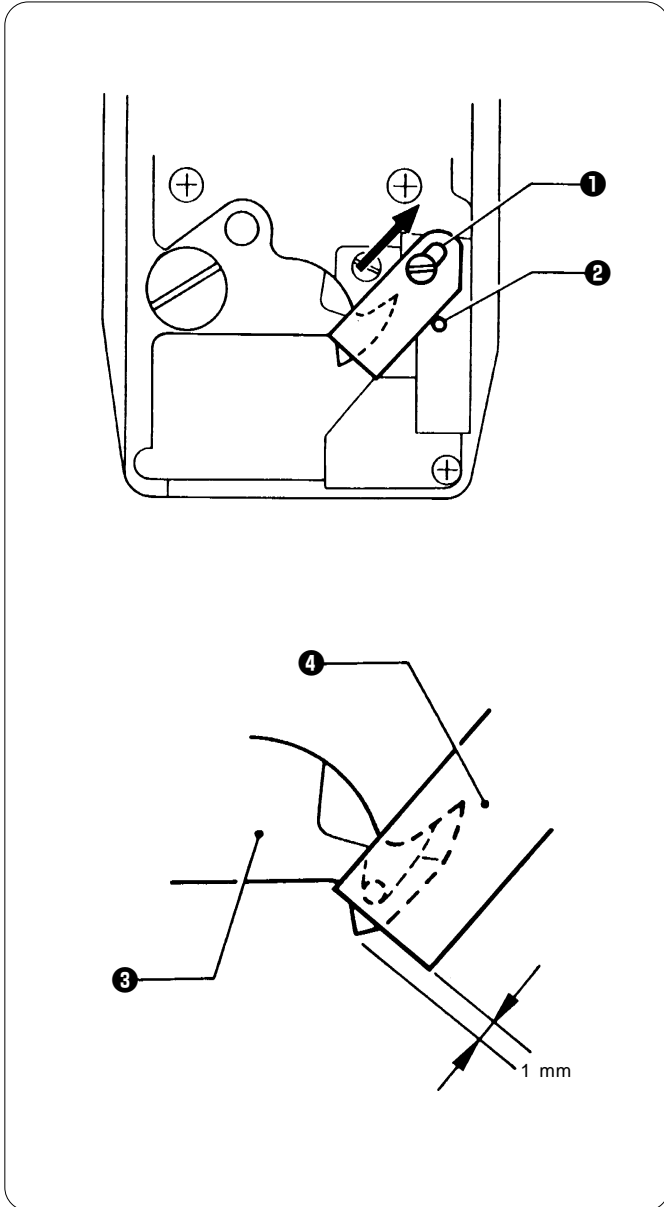

- After replacing the movable and fixed knives, attach them as follows:

### [Fixed knife position]

When attaching the fixed knife ①, while pressing it against the pin ②, move the fixed knife ① all the way backward until it stops at the end of its slot.

### [Movable knife position]

The tip of the movable knife ③ always should be positioned so that it projects 1 mm from the fixed knife ④. Adjust the position of the movable knife using the connecting rod so that it is the same as after thread trimming.

- Refer to "Adjusting the thread trimmer" in chapter 3, Standard Adjustment.
- Notes:
  - If a thread trimming error occurs, the pressure between the movable and fixed knives may be inappropriate even if they make contact with each other. In this case, put one or two spacers between the movable knife and the needle plate base to adjust the pressure.
  - When the movable knife is retracted too much, it can not go between the upper and lower threads, resulting in a thread trimming error.

# 15. Replacing and adjusting the lower shaft module

Note: Be sure to turn off the power before proceeding with that below.

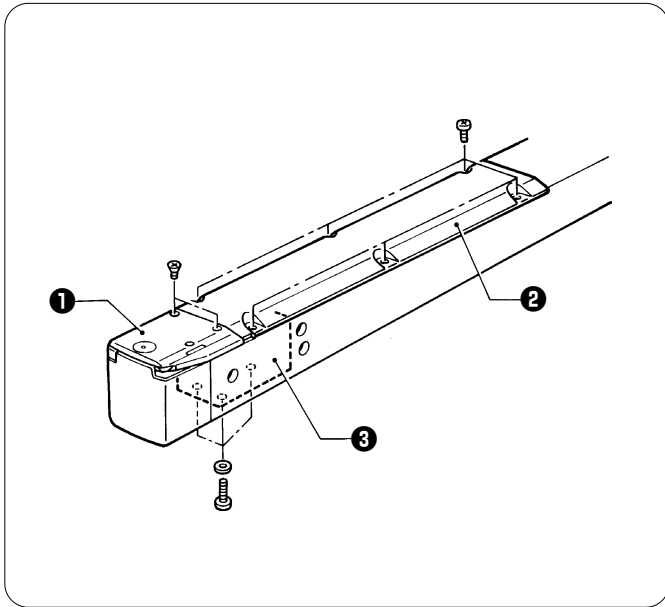

1. Remove the screws, needle plate B **1** and bed cover **2**.
2. Remove the three screws and washers securing the lower shaft case **3**.

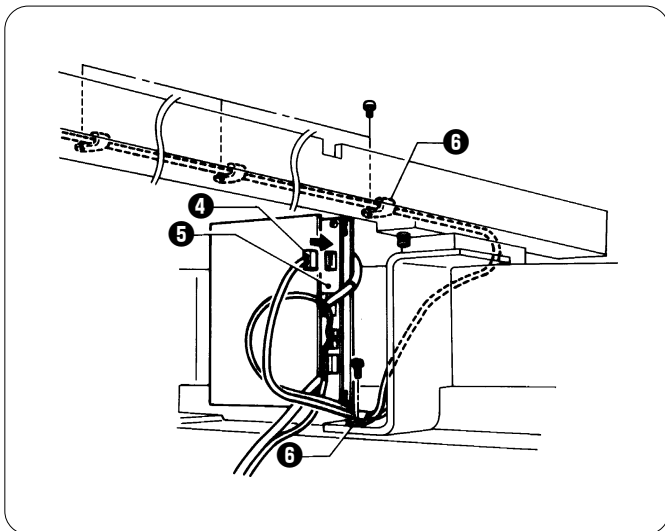

3. Remove the connector **4** of the lower shaft sensor harness and the connector of the lower shaft stepping motor harness from the BC PCB **5**. (At this time, remove the harness from the cord clamp **6**.)

Note:

Remove a connector if its harness is not connected to the connector on the PCB but connected in a cylinder.

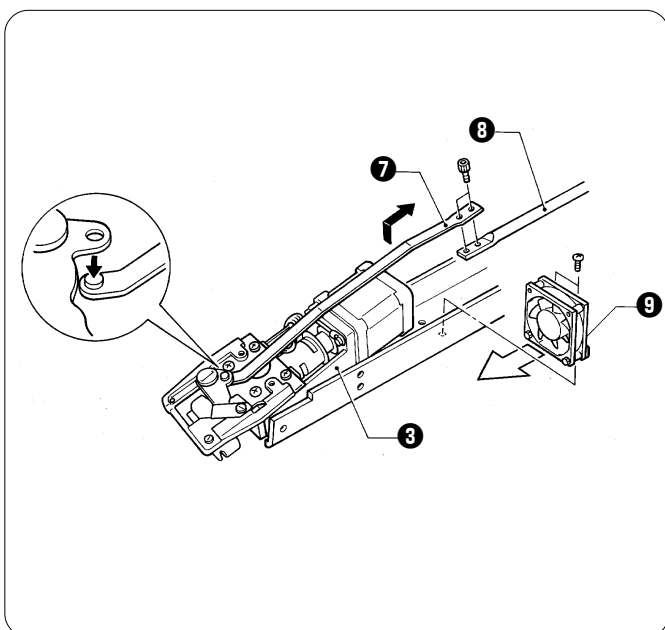

4. Remove the two bolts to separate connecting rod B **7** from connecting rod C **8**. (Leave the protrusion on the tip of the connecting rod off the movable knife.)
5. Remove the two screws, and the DC fan motor assembly **9** by lifting it upward.

Note:

The DC motor assembly is removed just for removing the lower shaft stepping motor harness and the lower shaft sensor harness. Keep the connector of the DC motor assembly attached.

6. Remove the lower shaft case **3**.
  7. After replacing the lower shaft module, reverse the above procedure for re-assembly.
- i Be sure to refer to the page indicating the items to be checked when replacing the lower shaft module.

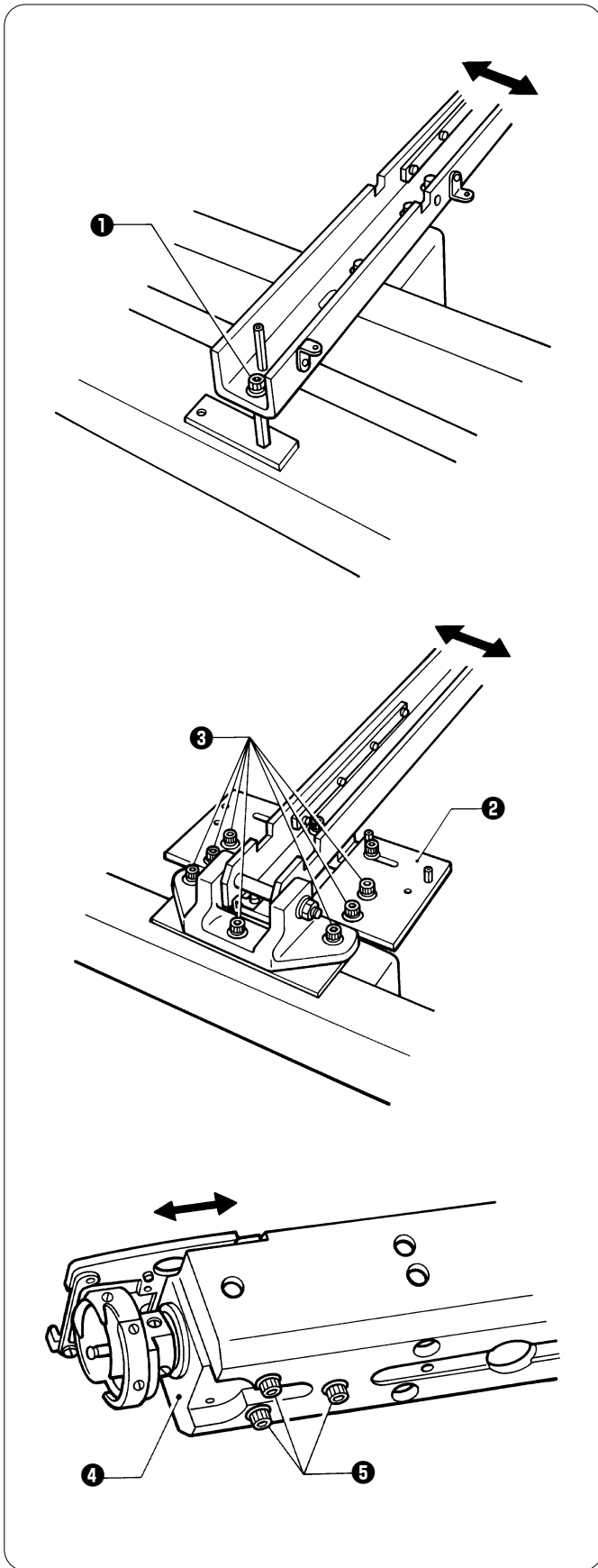

### [Adjustment]

#### Checking the needle penetration location

- Right and left adjustment  
Loosen the three bolts **1** for a fixed bed or seven bolts **3** securing bed support A **2** for a retracting bed. Move the bed in the direction of the arrow to adjust it.
- Position the needle bar case using the positioning bar, then set the needle at its lowest position to adjust it so that it is at the center of the outer rotary hook.

- Back and forth adjustment  
Loosen the three screws **5**, and move the lower shaft case **4** back and forth to adjust it.

#### Note:

- When checking the needle penetration point at the lower shaft module, be sure to adjust the thread trimming.
- As to the clearance or meeting point between the needle and rotary hook, refer to chapter 3.



## Items to be checked when replacing the lower shaft module

- When attaching the lower shaft module, make sure that the two harnesses of the lower shaft module are not caught between the lower shaft fan and the bed.
- When fixing the harnesses of the lower shaft module to the bed using the cord holder, be sure to attach them at the same position as they were before they were removed.
- When the bed and the lower shaft module are viewed from the front, make sure that the lower shaft module is securely attached to the bed without any inclination, and then adjust the needle penetration position.

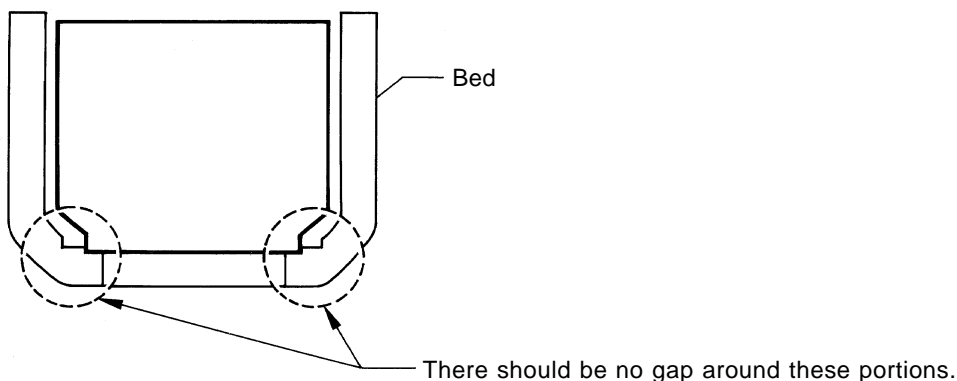

- When adjusting the needle penetration position, place the needle plate on the lower shaft module, turn the pulley 140 degrees, and tighten the screws and the bolts to fix the lower shaft module at the position where the needle is centered in the hole in the needle plate in the back and forth directions. Then, move the needle plate so that the needle is centered in the hole of the needle plate in the right and left directions. Make sure that the needle plate is parallel to the needle plate base.

### [Adjustment]

Loosen the four screws of the needle plate base, move the needle plate base with the needle plate temporarily attached, to the left and right to adjust the needle to the center of the hole in the needle plate.

#### Notes:

- After moving the needle plate base, be sure to adjust the thread trimmer.
  - When adjusting the needle penetration position, first adjust it for needle bar No.5, and then check the remaining needle bars for their needle penetration positions.
- When attaching the harnesses of the lower shaft module to the BC PCB, do not mistakenly attach the wrong connectors.

	Connector color (on BC PCB)	
Fixed bed	White (for cooling fan)	Red
Retracting bed	Blue (for cooling fan)	Blue

- Be sure to again adjust the needle bar height, timing position, the clearance between the needle and the rotary hook point, and the thread trimmer.
- Perform "8. BC Auto Test" (select on the BC test menu) as a final check. Refer to page 90, "Lower shaft module test."
- After adjustment, perform sewing and carefully check the lower shaft module at the highest speed. If there is an abnormal sound coming from the lower shaft module, again replace it with a new one.

## 16. Replacing the presser foot switch

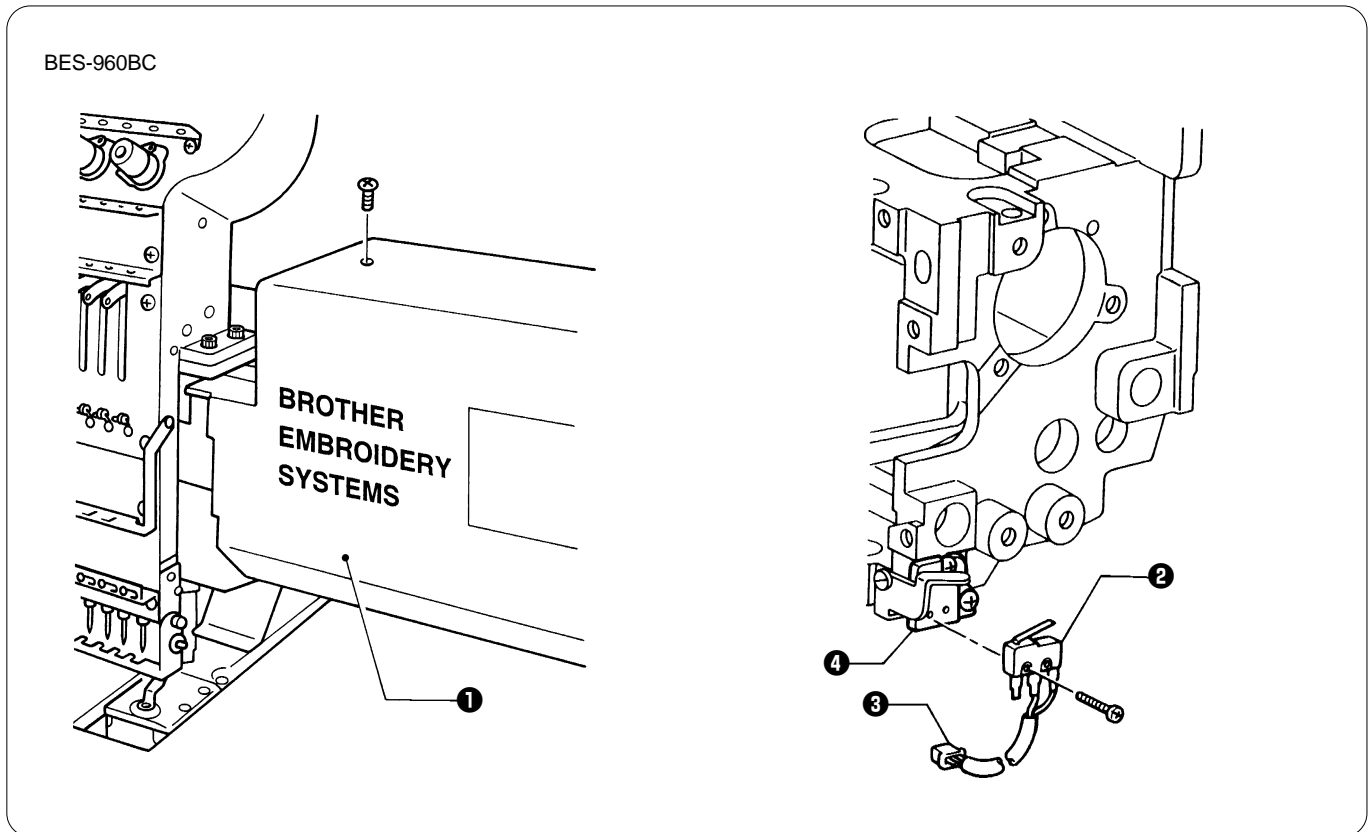

1. Remove the screw, and the cover ① on the right of the head you want to replace. (The figure shows head no. 1.)
  2. Remove the connector ③ of the switch ② from the head PCB.
  3. Remove the two screws, and separate the switch ② from the micro switch holder ④.
- Reverse the above procedure for re-assembly.

Note:

As to adjustment, refer to "9. Adjusting the switch" in chapter 3 Standard Adjustment.

# 17. Replacing and adjusting the solenoid that controls pulley

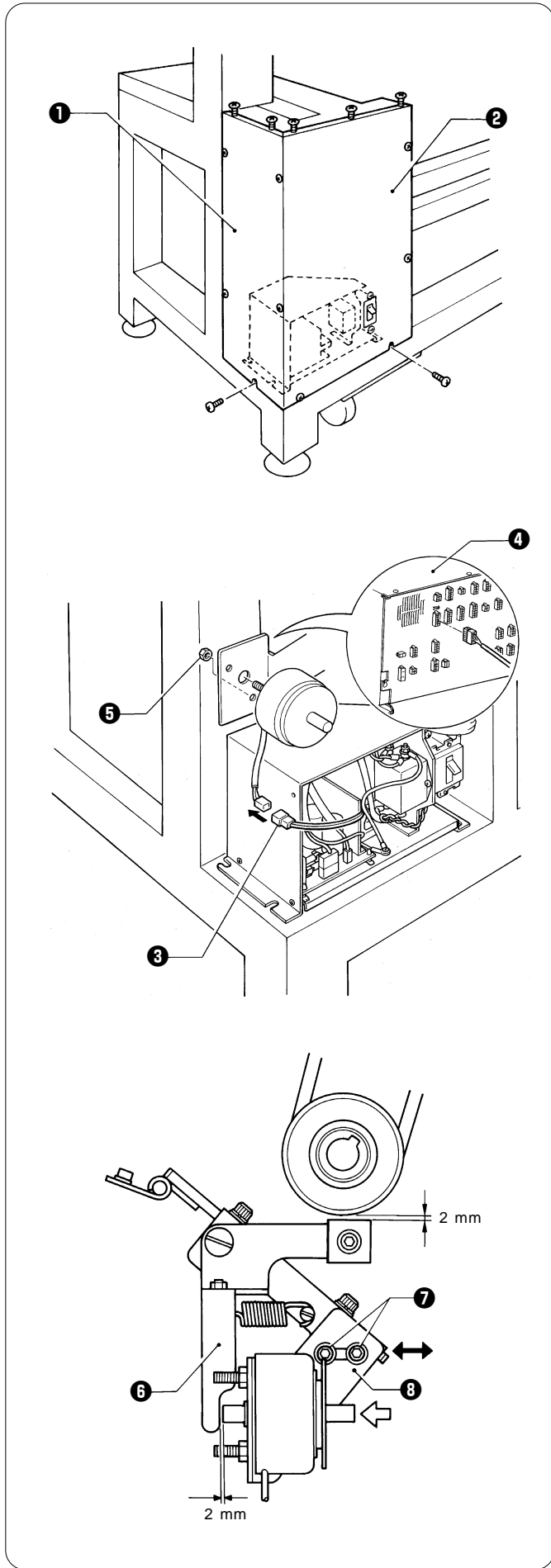

1. Remove the screws, and motor covers L **1** and F **2**.
  
2. Separate the connector of the solenoid from that of power supply PCB B **3**. Remove the connector from 20B on the rear of the control box **4**.
  
3. Remove the two nuts **5** and the solenoid.
  
4. After replacing the solenoid, reverse the above procedure for re-assembly.
  
5. With the solenoid turned off (when it has completely retracted), there should be a 2 mm clearance between the tip of the solenoid and the stop lever **6**. Loosen the two bolts **7** of the solenoid bracket **8** to adjust it in the direction of the arrow.

# Chapter 3 Standard Adjustment

## ⚠ CAUTION

⚠ Turn off the power switch and pull out the plug before starting adjustment. Failure to do so may start the machine unintentionally through an accidental activation of the START switch, resulting in bodily injuries.

- Adjustment

⚠ If adjustment should be made while the power switch is turned on, pay special attention to your safety.

⊘ Maintenance and inspection of the machine should be conducted only by trained engineers.

## 1. Adjusting Needle Bar Height

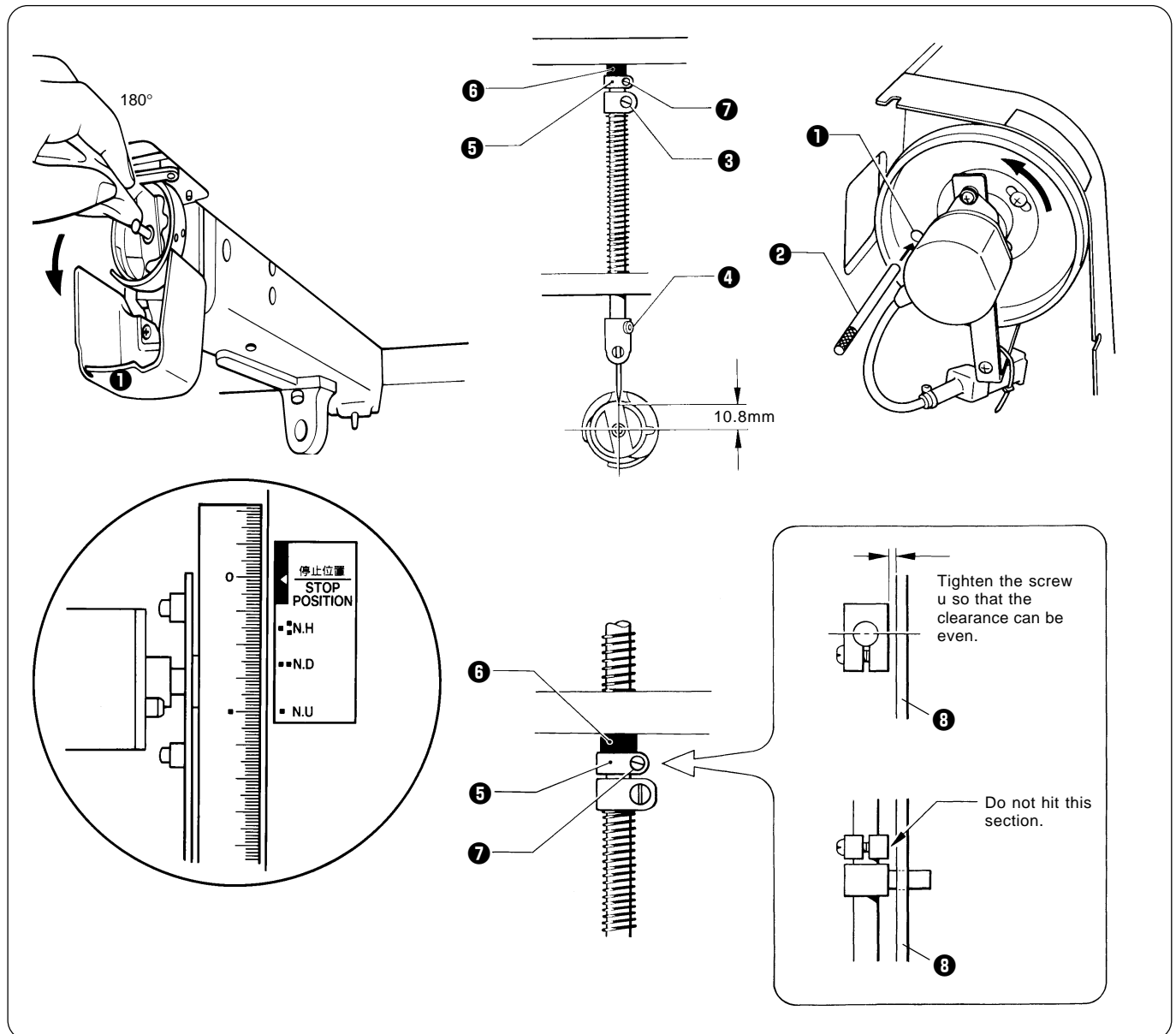

1. Dismount the pulley cover and turn the pulley ❶ until the pulley scale indicates 180° and the needle bar is set at the lowest position. (The pulley "■" mark and the stop mark "■" are aligned.)

2. Insert the positioning bar ❷ into the hole of the pulley ❶ and fix the drive shaft.

Note

Turn the pulley securely in the clockwise direction to eliminate a backlash.

3. Loosen the needle bar clamp set screw ❸ when the needle tip is positioned 10.8 mm above the center of the rotary hook shaft. Adjust the position of the needle bar thread guide so that the set screw ❹ on it is turned to the right by 25 ~ 30°. Tighten the needle bar clamp set screw ❸ securely.

Note

When tightening the needle bar clamp set screw ❸, the hole in the needle bar guide should face the front.

4. After adjustment is finished, remove the positioning bar ❷.

5. Set the needle bar at the highest position (where the pulley indication mark "■" and the cover indication mark "■" are aligned). Lightly press the top dead center stopper ❺ toward the cushion rubber ❻, and tighten the top dead center stopper screw ❼ while pressing down the needle bar clamp so that it faces the front.

Note

- Make sure that the top dead center stopper does not hit the needle bar guide rail ❸ at this time.
- When tightening the bolt 6 of the top dead center stopper, use the accessory wrench, insert the longer side of the wrench into the bolt head, and tighten it.  
(If the bolt is tightened too much, the needle bar may be sluggish.)
- After adjustment, make sure that the needle bar can return to top dead center when it is pressed down 10 mm and then released.
- The (rotation) direction of the needle bar may be changed after its height is adjusted. Make sure that the long groove of the needle faces the front.

When using the bottom dead center gauge

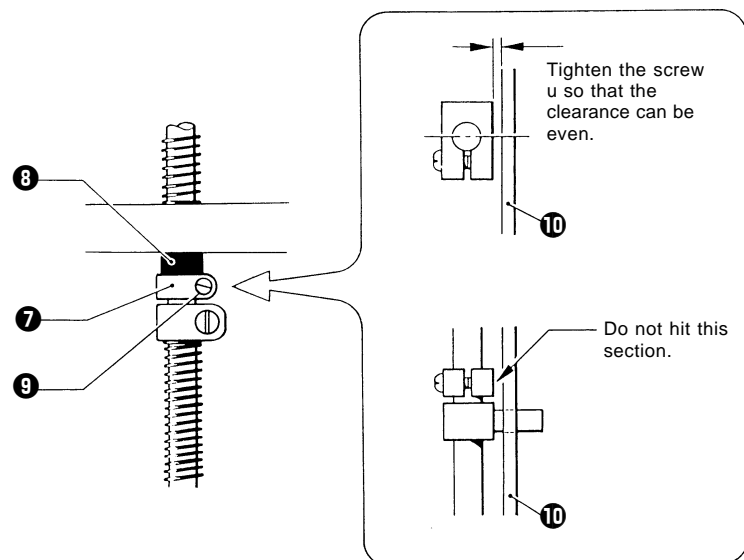
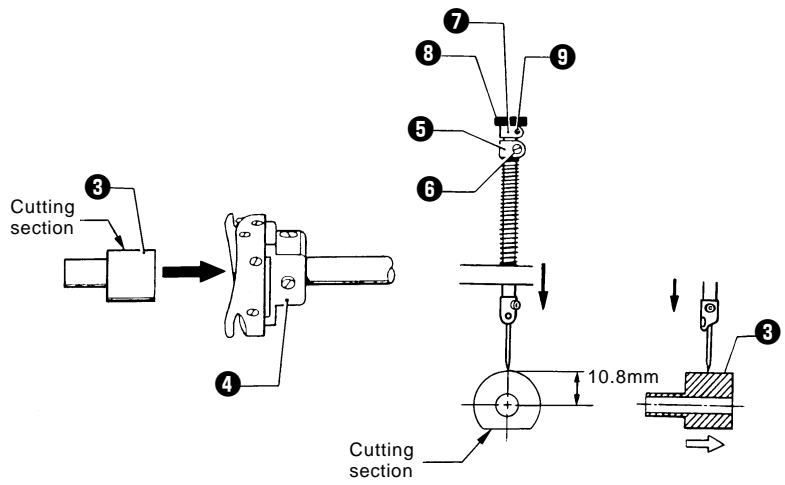
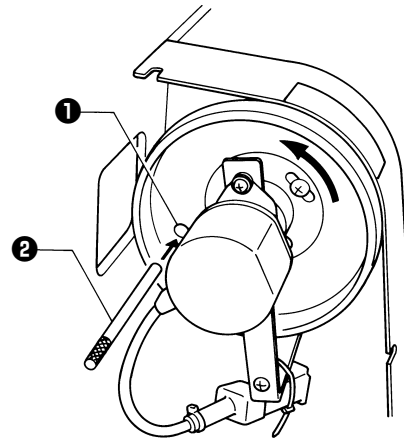
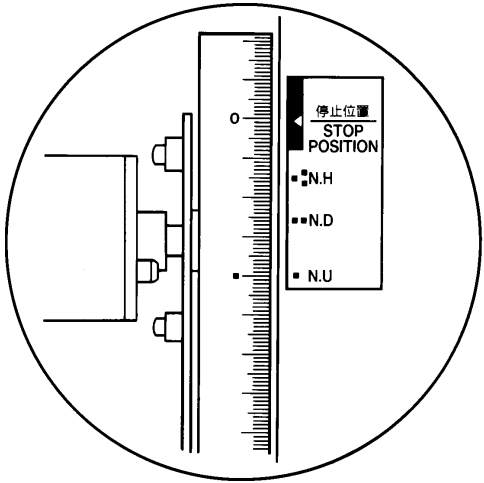
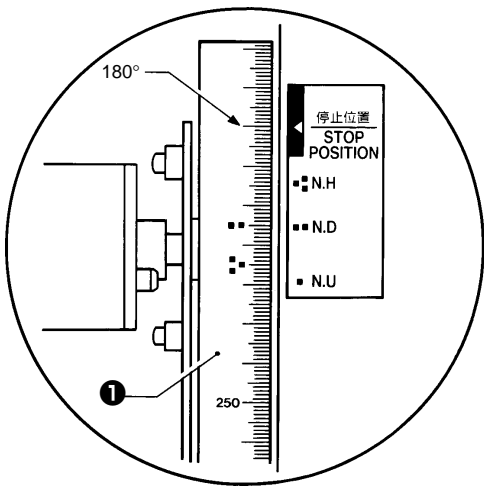

1. Turn the pulley ❶ until the scale of pulley ❶ indicates 180° (where the pulley indication mark "■" and the stop mark "■" are aligned) and the needle bar is set at the lowest position.
2. Insert the positioning bar ❷ into the hole of the pulley ❶ and fix the drive shaft.  
Note:  
Turn the pulley securely in the clockwise direction.
3. Insert the bottom dead center gauge ❸ into the rotary hook ❹.
4. Loosen the screw ❺ of the needle bar clamp ❻ and move the needle bar up and down until the needle tip touches the gauge ❸ lightly.  
Note:
  - The needle point should touch the gauge at a place other than the cutting section.
  - The bottom dead center gauge should be set in or removed from the rotary hook with its cutting section facing upward.
5. Tighten the screw ❻ of the needle bar clamp ❸ securely.
6. After adjustment is finished, remove the positioning bar ❷.
7. Set the needle bar at the highest position (where the pulley indication mark "■" and the cover indication mark "■" are aligned). Lightly press the top dead center stopper ❽ toward the cushion rubber ❾, and tighten the top dead center stopper screw ❿ while pressing down the needle bar clamp so that it faces the front.  
Note:
  - Make sure that the top dead center stopper ❽ does not hit the needle bar guide rail ⓫ at this time.
  - When tightening the bolt 6 of the top dead center stopper, use the accessory wrench, insert the longer side of the wrench into the bolt head, and tighten it.  
(If the bolt is tightened too much, the needle bar may be sluggish.)
  - After adjustment, make sure that the needle bar can return to top dead center when it is pressed down 10 mm and then released.
  - The (rotation) direction of the needle bar may be changed after its height is adjusted. Make sure that the long groove of the needle faces the front.

## 2. Adjustment of Clearance Between Needle and Rotary Hook

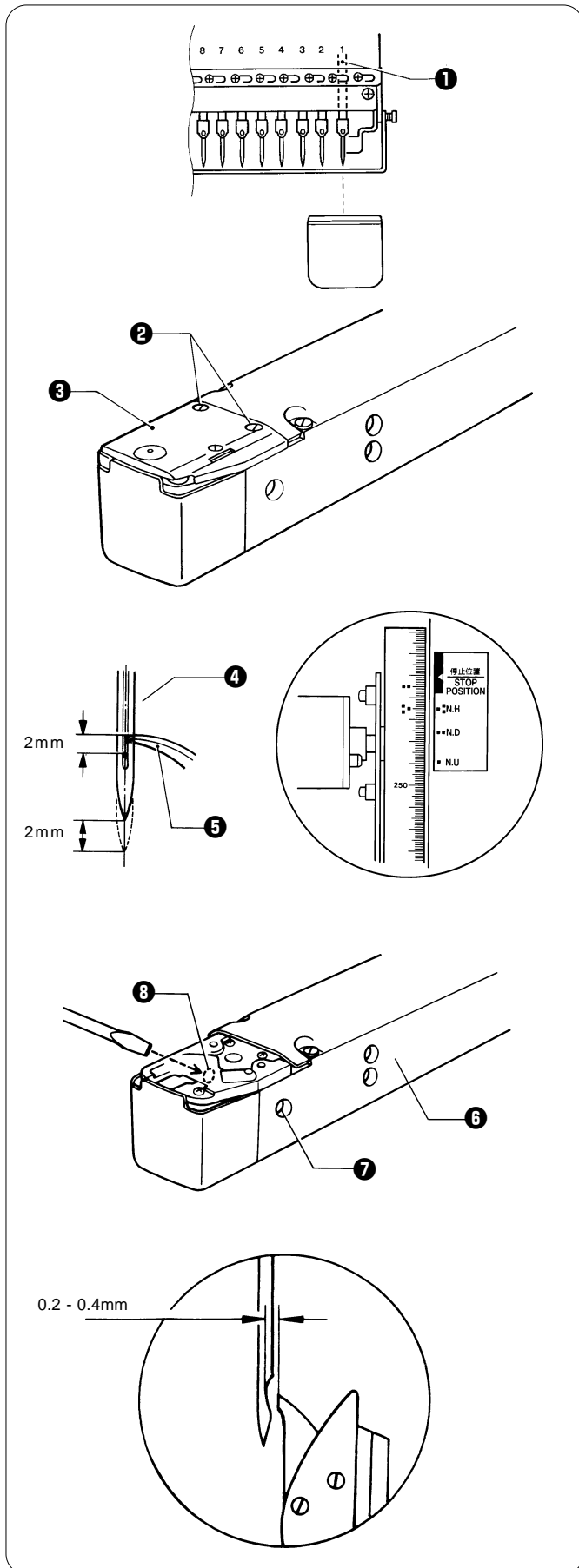

1. Turn the power switch off.
2. Select the needle bar No. 1 **1**.
3. Remove two flat screws **2** and dismount the needle plate **3**.
4. Adjust the needle **4** and the rotary hook's **5** point so that they can put together at 2 mm above the needle bar lowest point (180°) where the pulley indication mark "■" and the stop mark "NH■" are aligned.
5. Turn the rotary hook manually so that the point comes upward.
6. Loosen the set screw **7** on the side of the bed **6**.
7. Turn the eccentric screw **8** on the left side of the bed **6** using a regular screwdriver and adjust a clearance between the needle and the rotary shaft to 0.2 - 0.4 mm.  
Note:  
Check that the needle bar height is 2 mm at this time.
8. Adjust the clearance between the needle and the rotary hook's point to 0.2 - 0.4 mm at the needle bar No. 9 **9** (No. 12 needle for BES-1260BC).  
Note:
  - If the clearance between the needle and the rotary hook point is not within 0.2 - 0.4 mm, again perform from step 4 as described above, and set the smaller clearance between either needle bar No.1 or 9 (No.1 or 12 for BES-1260BC) and the rotary hook point to approx. 0.2 mm.
  - If the clearance between the needle and the rotary hook point is 0.5 mm or more, replace the needle and the needle bar with new ones.
  - If the clearance is too small when a thicker material is sewn, the needle may be bent or broken.



### 3. Adjustment of Timing Between Needle and Rotary Hook

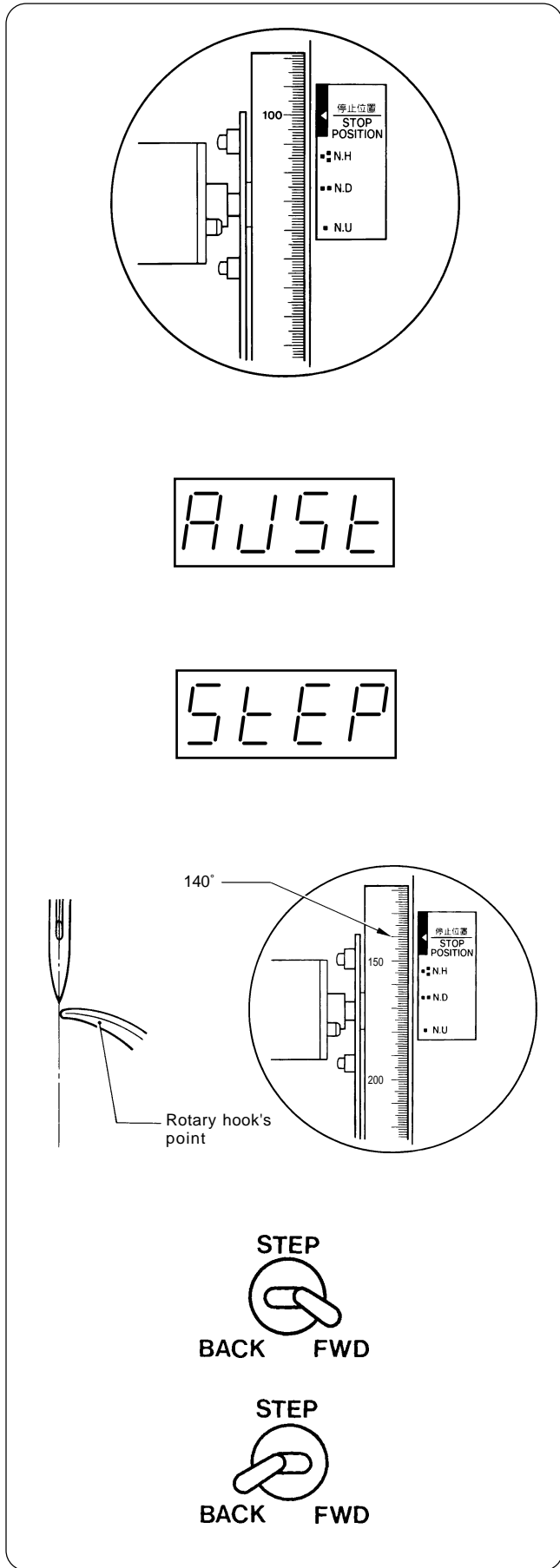

1. Turn the power switch on.
2. Check that the machine pulley is at the stop position (at 100° of the scale). If not, turn the pulley until it comes to the stop position.
3. While the machine is at the stop position, press the JOG switch (▽) while holding down the STOP switch. "AJST" is indicated on the display.



4. Pressing the START switch. "STEP" is indicated. The rotary hook in each machine head rotates to the currently set timing position and the rotary hook can be adjusted.

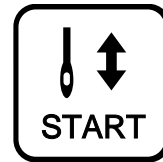

5. Turn the machine pulley manually until the relationship between the needle point and the rotary hook's point can be easily checked (at around 140° of the scale).
6. Press the STEP BACK/FWD switch to move the rotary hook for each head to adjustment.
  - STEP BACK  
For rotating the rotary hook little by little in the clockwise direction
  - STEP FWD  
For rotating the rotary hook little by little in the counter-clockwise direction
 Make this adjustment for each machine head so that the needle and the rotary hook's point can fit with each other.

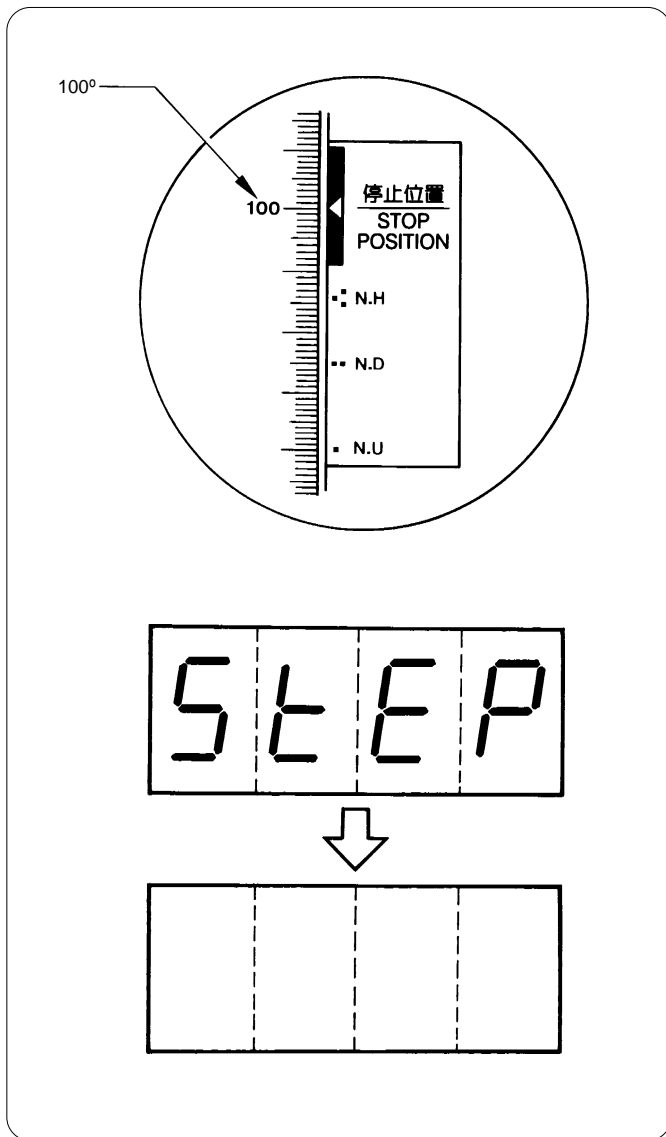

7. After timing adjustment the is finished for each head, set the pulley to the stop position (at 100° of the scale) and press the STOP switch. "STEP" disappears from the display, and the machine enters the standby state.



The adjustment of the rotary hook is completed and the timing is stored. The rotary hook returns to the stop position accordingly.

## 4. Adjusting the clearance between the rotary hook and the inner rotary

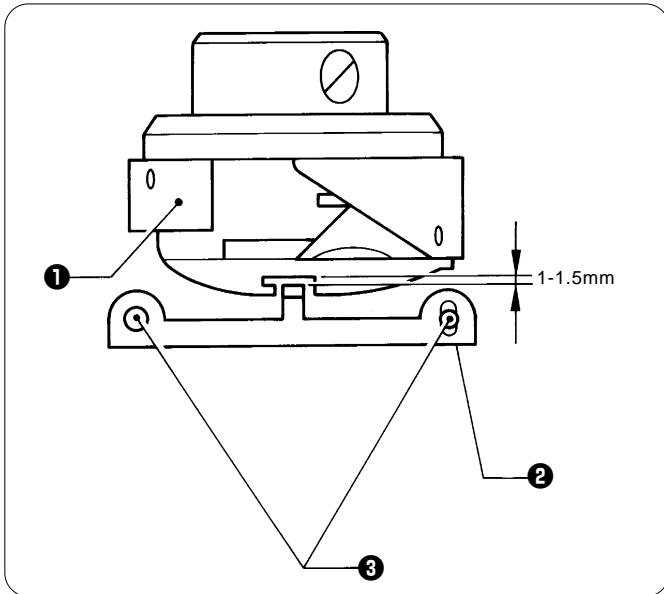

1. The clearance between the rotary hook **1** and the inner rotary hook stopper **2** should be enough to pass the thread through the clearance easily.
2. Loosen the two screws **3** to adjust the clearance between the rotary hook and the inner rotary hook stopper to 1-1.5mm.
3. Lower the needle. Make sure that the inner rotary hook stopper **2** is inserted into the center of the groove of the rotary hook **1**.

Notes:

- If the rotary hook stopper does not come to the center of the needle, the needle or the needle bar may be bent. If both are not bent, replace the rotary stopper with a new one.
- If there is no problem with the needle or the needle bar, set the needle to its bottom dead center to check if the needle comes to the center of the shaft of the outer rotary hook. If it does, move the needle plate base to the left and right to center the needle.  
(At this time, re-adjust the thread trimmer.)  
If it does not, adjust the needle penetration position.

## 5. Adjustment of Presser Foot Height

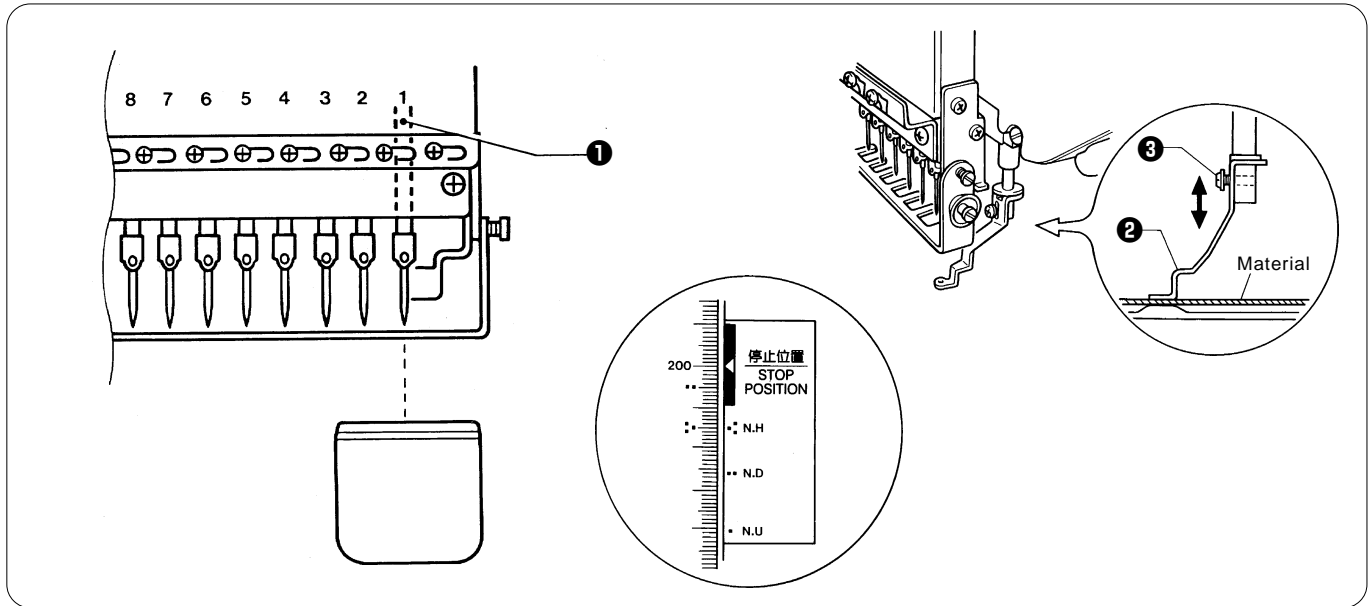

1. Turn the power switch off.
2. Select the needle bar ① No.1.
3. Loosen the screw ③ of the presser foot ②, and adjust the presser foot ② until it comes above the cloth top surface when it is at the bottom dead center (where the pulley indication mark "■" and the cover indication mark "■" are aligned).

### Adjusting the position of the presser shaft

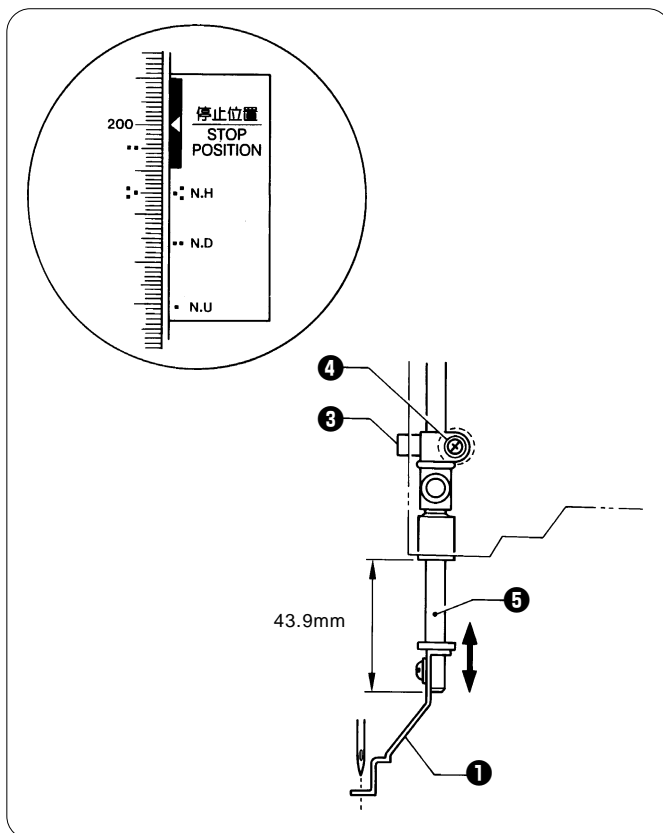

1. Turn the pulley to set the presser foot to its lowest position. (Turn the pulley until ■ mark on the pulley is aligned with the one on the belt cover.)
2. Loosen the screw ④ of the presser shaft clamp ③ using a screwdriver inserted through the hole in the side of the machine head. Adjust the position of the presser shaft ⑤ so that the presser shaft ⑤ is 43.9mm. [Adjustment]  
Turn the pulley until the ■ mark on the pulley is aligned with the one on the belt cover. Attach the presser foot ④, which is lowered to the bottom dead point, to the presser shaft clamp ③. Loosen the screw ② of the presser shaft clamp ① at the place where the bottom of the presser foot makes contact with the needle plate (for holder base).
3. Securely tighten the screw ④ of the presser shaft clamp ③.
4. Make sure that the needle is inserted into the center of the hole in the presser foot ① when it is lowered.

## 6. Adjustment of Thread Trimmer

### 6-1. Attaching the Fixed Knife

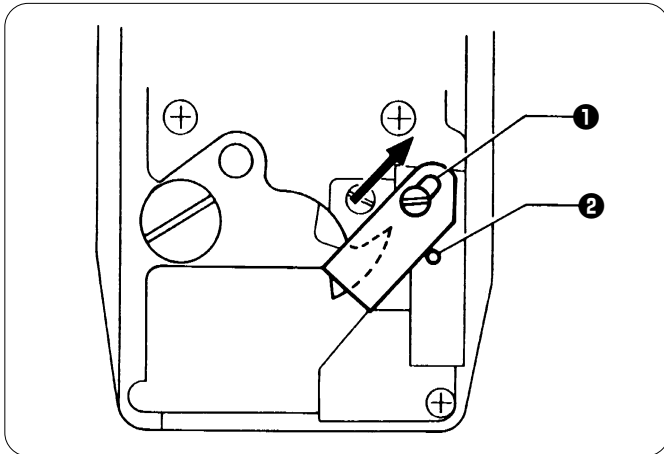

Attach the fixed knife **1** to the pin **2** and move it backward to the end of the slot, then mount it there.

### 6-2. Checking the Movable Knife Position

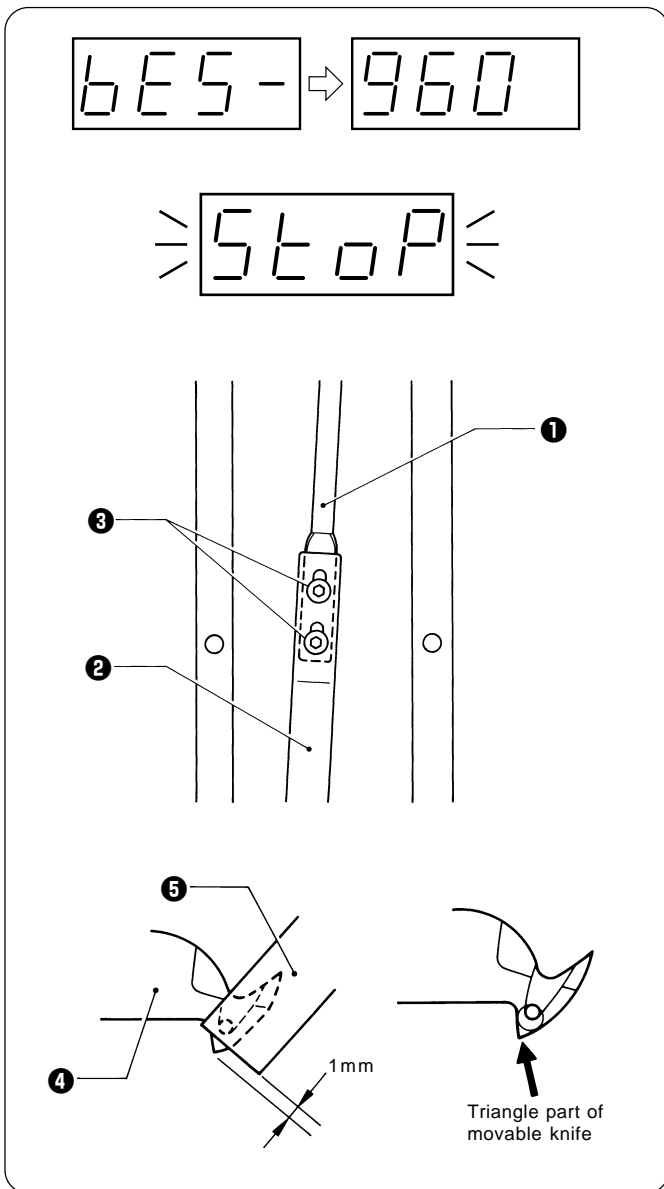

1. Turn the power switch on and wait until the hoop home position detection is finished.
2. Press the JOG switch ( $\Delta$ ) immediately after pressing the Emergency stop button.

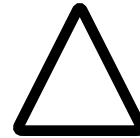
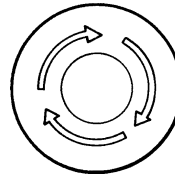

Adjust the movable knife position in this state.

3. Loosen two bolts **3** that connect the thread trimmer connecting rods B **1** and C **2**.
4. Tighten the two bolts **3** until the triangle part of the movable knife **4** is projected by 1 mm from the fixed knife **5**.

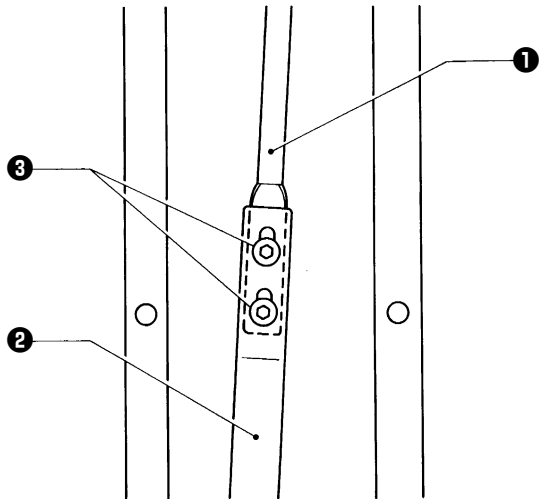

\*Bad example

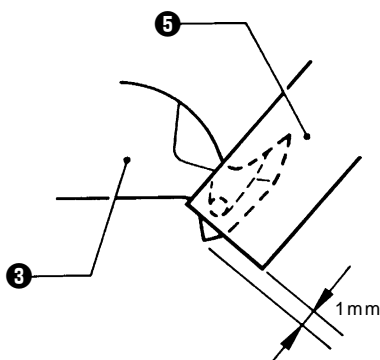
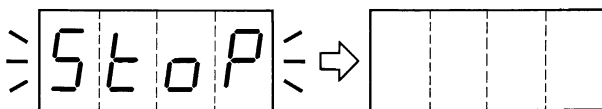
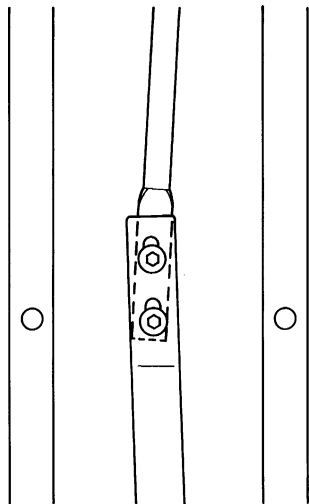

- \* Precautions for tightening the two bolts ③:
- The thread trimmer connecting rod B ① has a backlash of about 0.1 - 0.2 mm back and forth. Tighten the two bolts ③ while pulling them forward by the backlash amount.
- Tighten the two bolts ③ so that the thread trimmer connecting rods B ① and C ② are positioned in a straight line.

5. After adjustment is finished, reset the emergency stop button.  
"STOP" stops blinking and disappears.

6. Turn the power switch off once, then on again. Check that the clearance between the movable knife ④ and the fixed knife ⑤ is 1 mm.

7. When adjusting again, follow the step 2 and after.  
Note:  
When the movable knife is retracted too much, a thread trimming error may occur.

### If thread trimming error often occurs

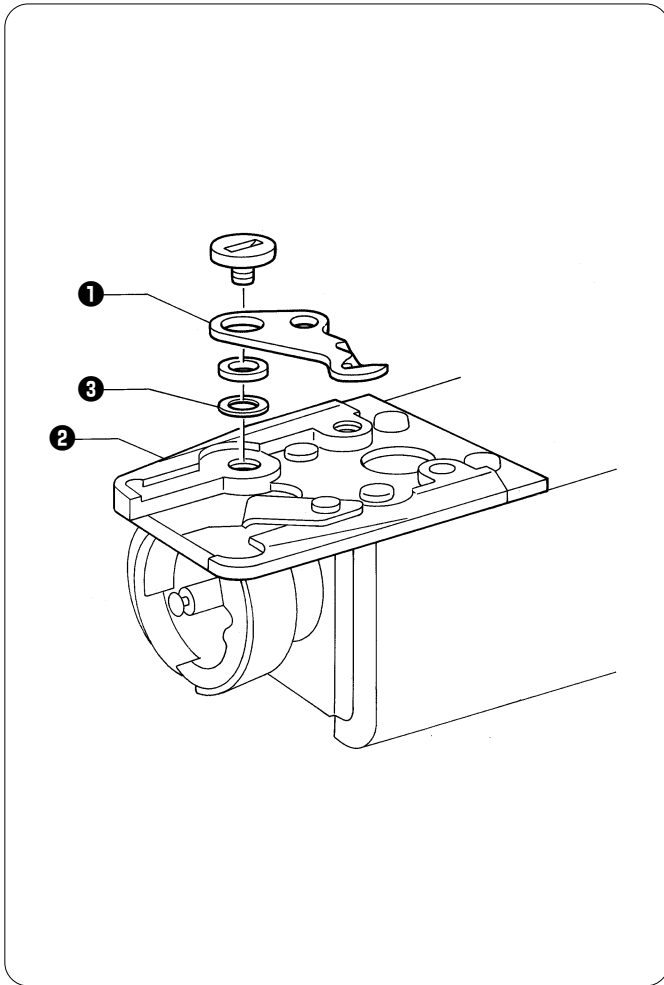

When the upper thread is trimmed, a thread trimming error occurs due to inappropriate pressure between the movable and fixed knives even if they make contact with each other. In this case, put one or two spacers (3) between the movable knife (1) and the needle plate base (2) to adjust the pressure.

**Note:**

Adjust the pressure between the fixed and movable knives by putting two threads of rayon 122 between them and carrying out thread trimming.

## 7. Adjusting the thread wiper

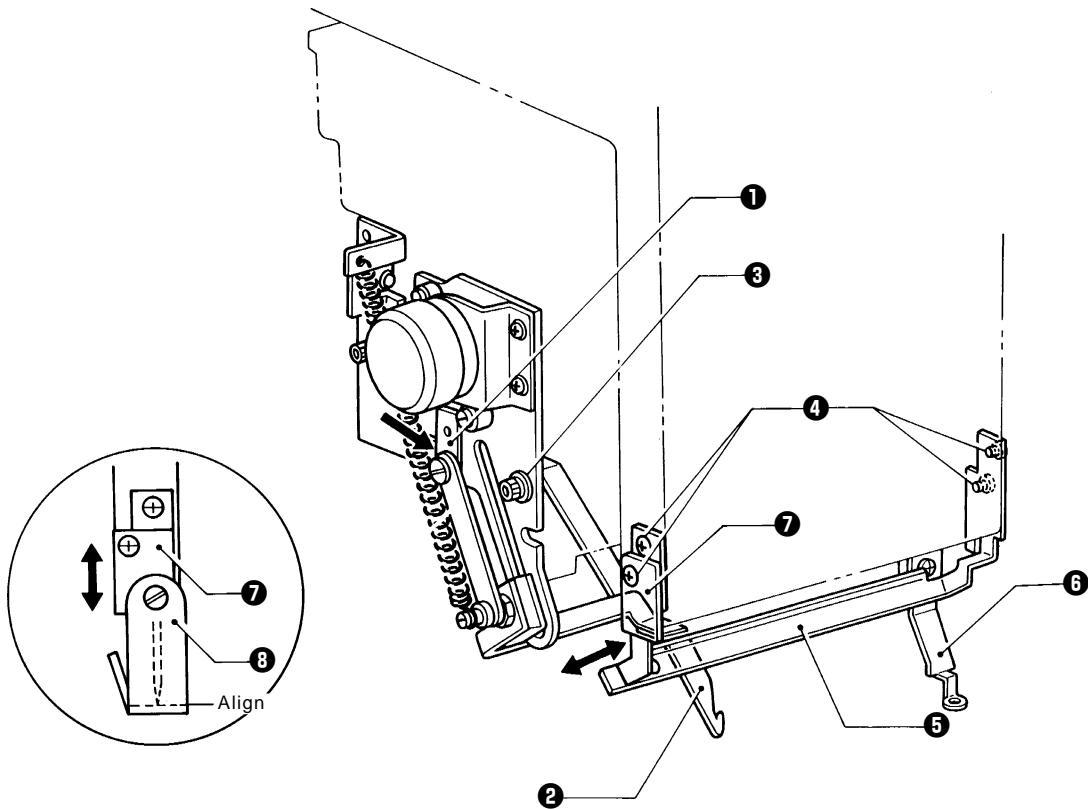

BES-960BC

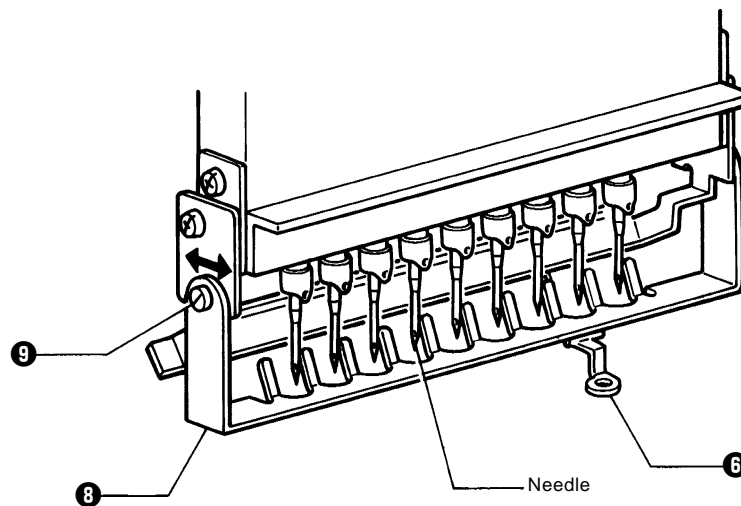

1. Move the solenoid arm **1** in the direction of the arrow with your finger. Loosen the three bolts **3** to adjust the thread hook **2** so that it can move easily.
2. If there is a difference in motion between needle bars no. 1 and no. 9, loosen the four screws **4**, and move the thread presser base **5** in the direction of the arrow.
3. Move the finger guard plate **7** vertically until the surface of the finger guard **8** is aligned with the tips of the needles.

### Notes:

- If the finger guard plate is inclined or excessively pushed toward the needle during color change, the presser foot may come into contact with the finger guard.
- In this case, move the bolt **9** of the finger guard **8** back and forth to adjust it.



## 8. Adjusting the jump solenoid

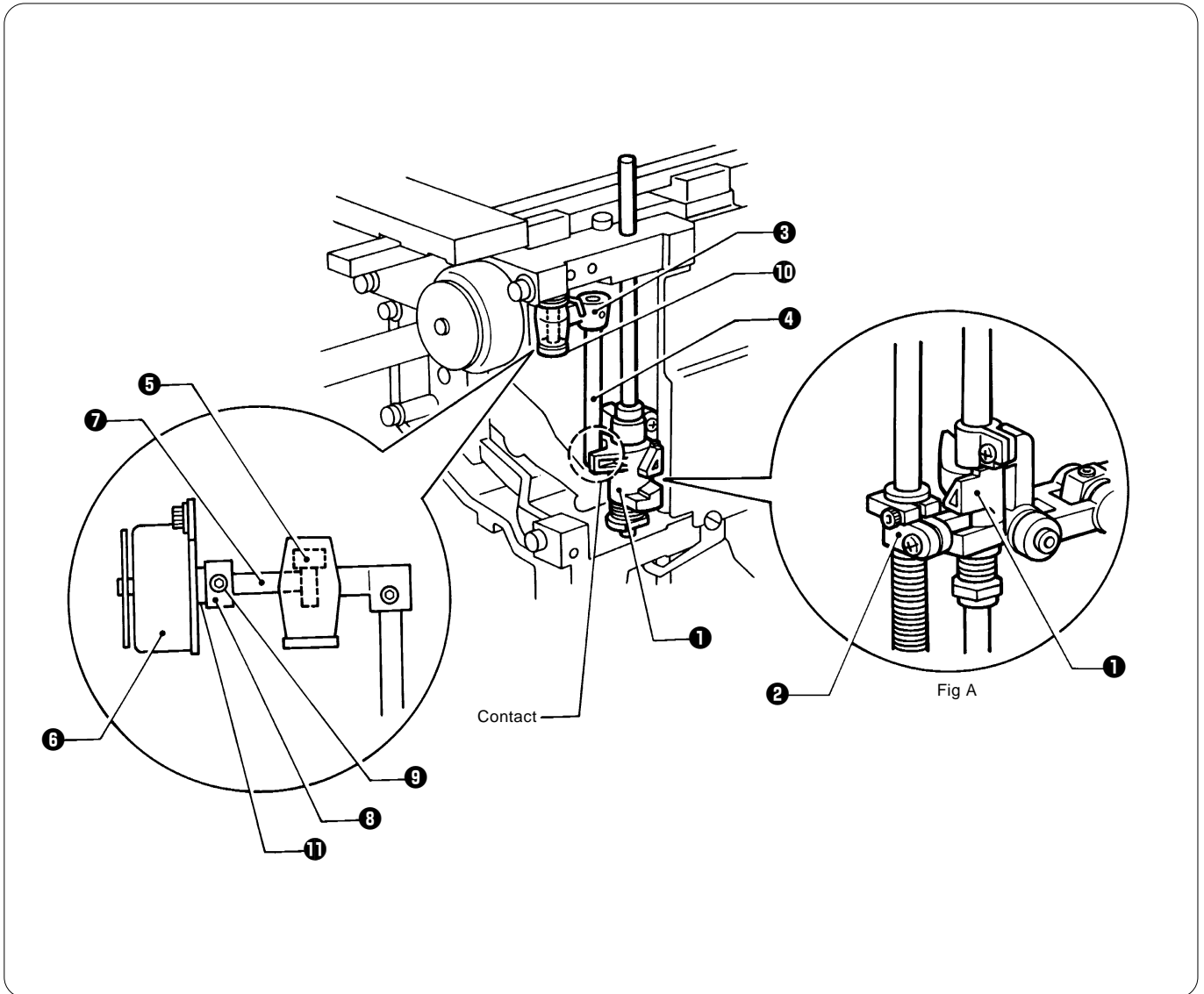

1. Make sure that the projection of the jump bracket **1** completely fits into the recess of the needle bar clamp **2**. (Refer to figure A.)
2. Make the jump rotary pipe **4** of the jump rotary body assy **3** make contact with the jump bracket **1**. Make the plunger **7** of the jump solenoid **6** make contact with the jump rotary body shaft **5**, which is opposite the jump rotary body **3**. Place the solenoid cushion **11** between the jump solenoid **6** and the set collar **8**, and tighten the set screw **9**.
3. Adjust the jump guide shaft **10** and the set collar **8** so that the needle bar clamp **2** can be taken off the jump bracket **1** when the plunger **7** of the jump solenoid **6** is at the stroke end.

Note:

After adjustment, make sure that, at low speed, the jump solenoid always jumps and returns to its original position as shown in the above enlarged figure, part A.

## 9. Adjusting the switch

BES-960BC

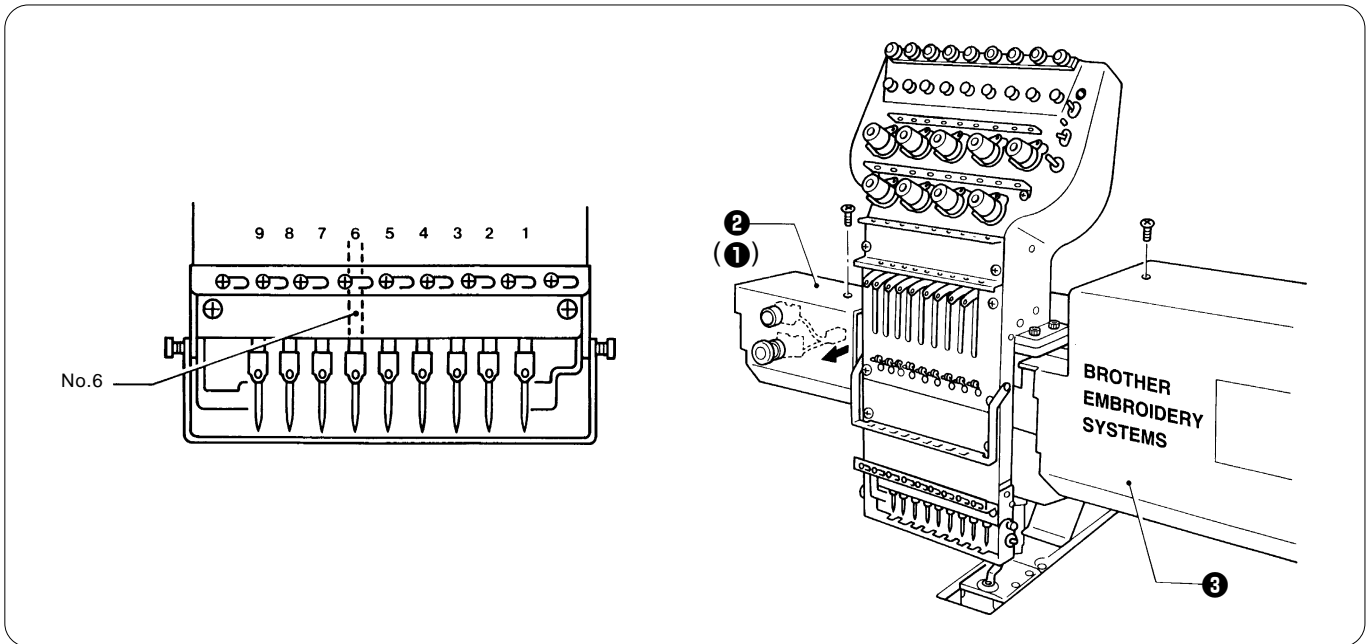

1. Select needle bar no.6, and turn off the power.
2. Remove screws, the UR cover ①, the UR switch cover ②, and the cover ③.

Note:

When removing the UR switch cover, remove the emergency stop switch connector.

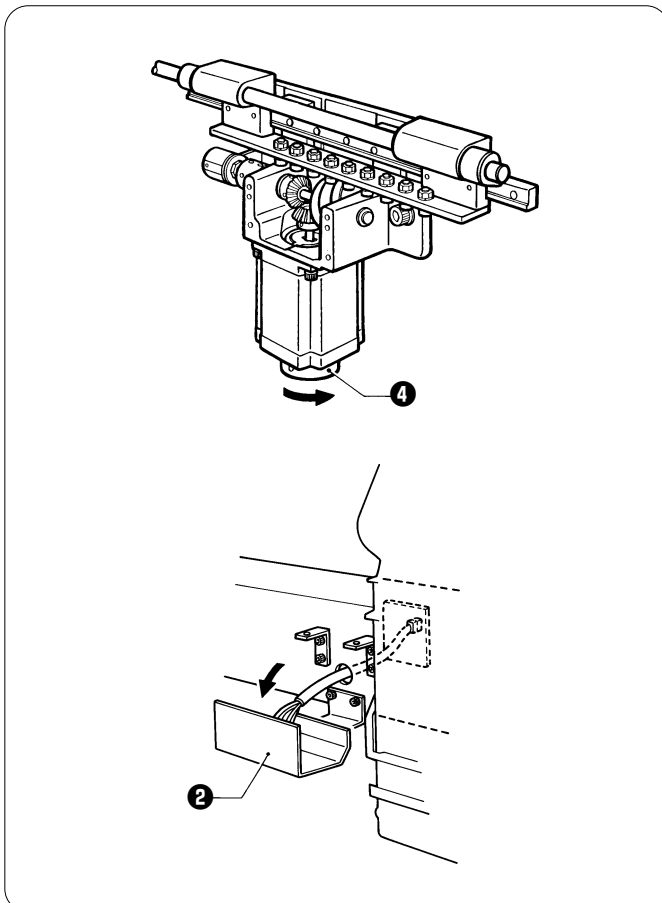

3. Turn the change pulley ④ to set needle bar no. 1.

4. Attach the emergency stop switch connector of the UR switch cover ②. The UR switch cover ② will hang down.

BES-1260BC

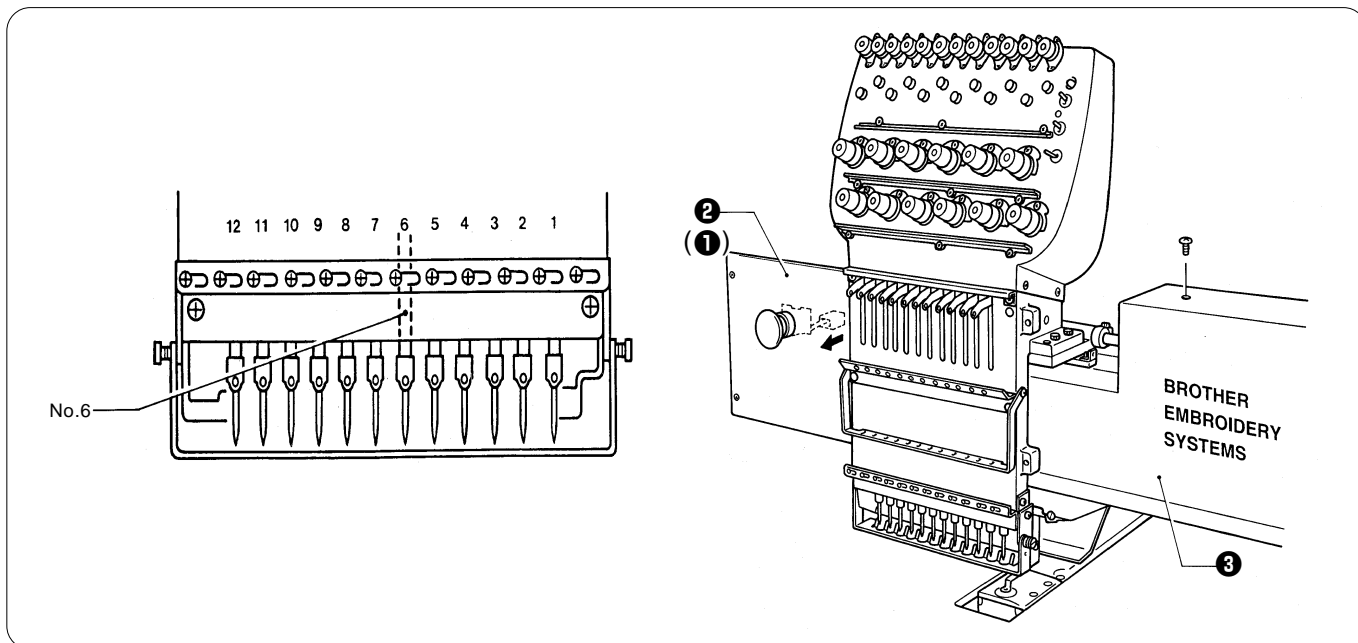

1. Select needle bar no.6, and turn off the power.
  2. Remove screws, the UR cover ①, the UR switch cover ②, and the cover ③.
- Note:  
When removing the UR switch cover, remove the emergency stop switch connector.

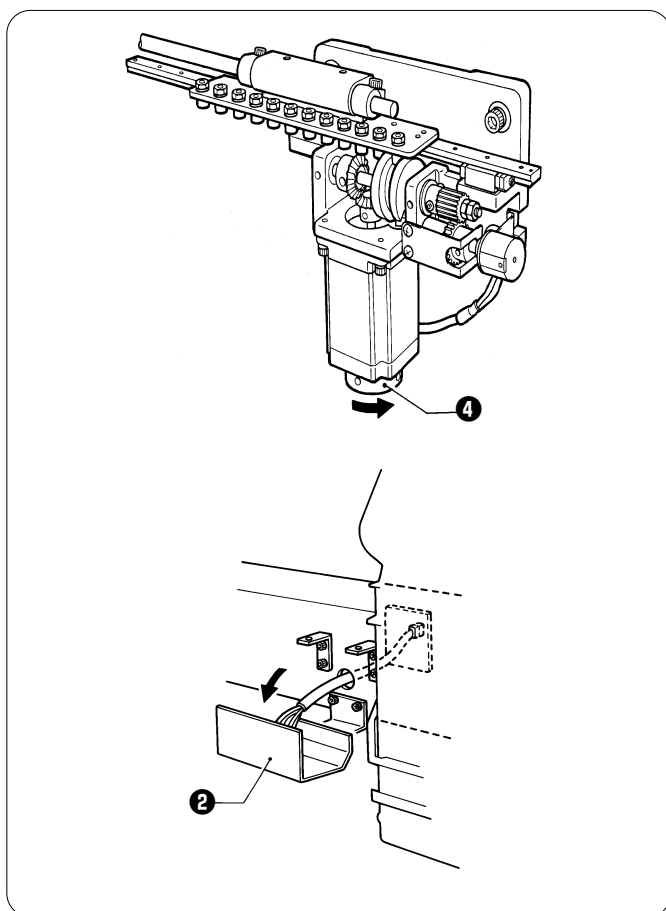

3. Turn the change pulley ④ to set needle bar no. 1.

4. Attach the emergency stop switch connector of the UR switch cover ②. The UR switch cover ② will hang down.

5. While pressing the jog switch ( $\nabla$ ) on the machine panel, turn on the power.

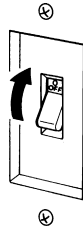
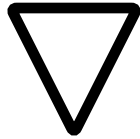

**Note:**

When turning on the power along with simultaneously pushing the jog switch ( $\nabla$ ), the home positioning of the carriage is not performed. Since it is not in the home position, do not perform normal sewing.

6. While pressing the stop switch, press the jog switch ( $\Delta$ ) to enter the test mode. "tcut" will appear.

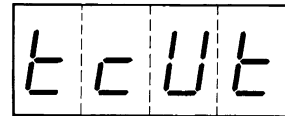
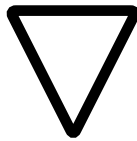

Press the jog switch ( $\triangleright$ ) to display "Foot."

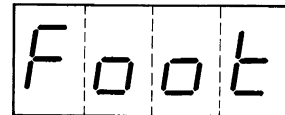

7. Make sure "Foot" appears, and press the start switch. The presser foot will lower.

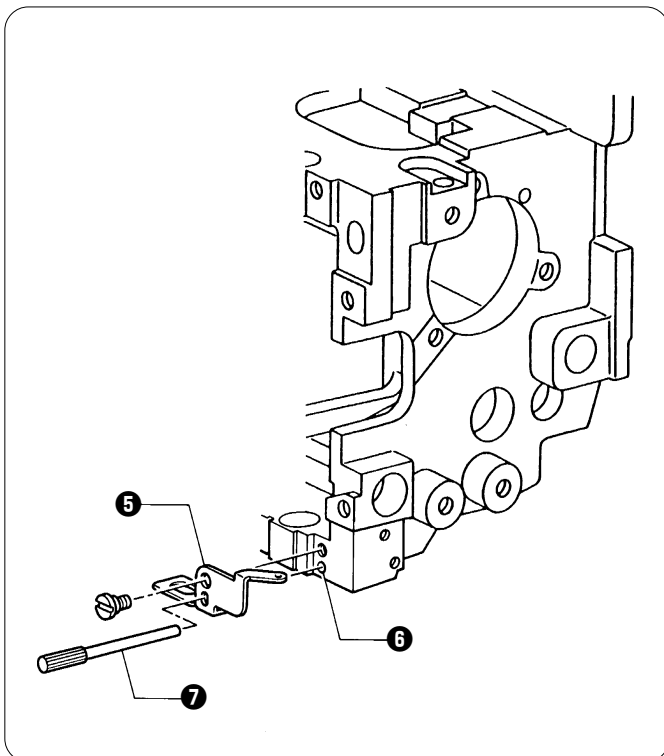

8. Match the slot of the W motor sensor plate **5** and  $\varnothing$  3 mm diameter hole in the head **6**, and insert the gauge pin **7** to secure the W motor sensor plate **5**.

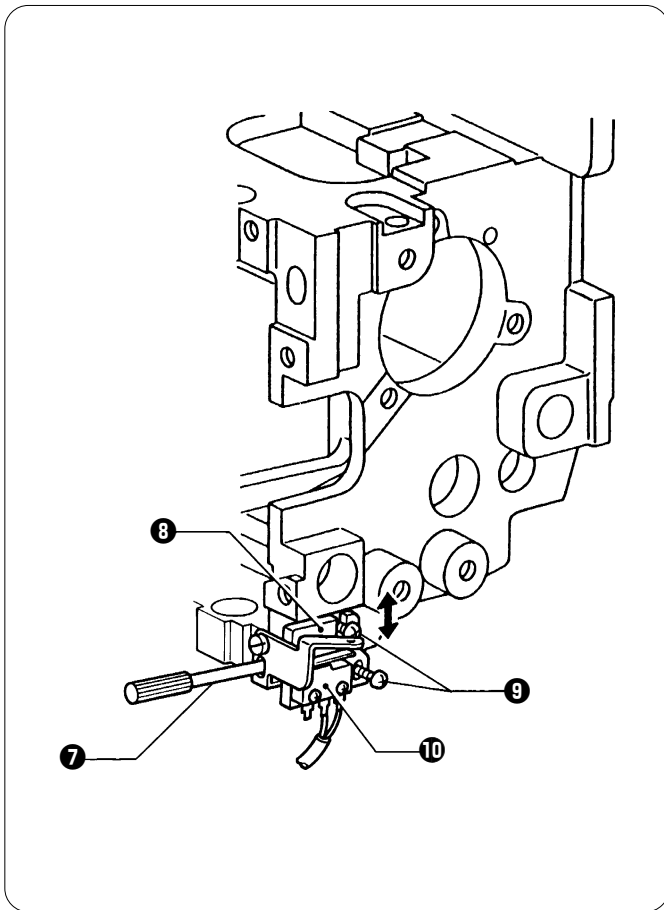

9. Loosen the two screws ⑨, and vertically move the micro switch holder ⑧, which is on the lower right of the head, until the switch ⑩ is turned on, and then secure the micro switch holder ⑧.
  - When the switch ⑩ is on, the buzzer sounds and the MENDING lamp (green) on the head is lit.

Note:  
Secure the micro switch holder ⑧ in the position just after the switch ⑩ is on.  
If it is secured at a higher position at that time, the presser foot may retract at a lower position.
10. Remove the gauge pin ⑦, and adjust the switch on each head in order.

11. After all heads are adjusted, make sure the presser foot rises and lowers normally by pressing the jog keys (△) and (▽) on the panel.
  - In particular, make sure the presser foot does not make contact with the thread clamp when the presser foot is rising.



12. Press the stop switch twice to finish the test mode, and turn off the machine.



13. Turn the change pulley ④ to select needle bar no. 6, and reattach the covers.

14. Turn on the power. Make sure that the presser foot rises and the carriage moves to the home position.
  - If "STOP" appears at this time, the emergency stop switch connector of the UR switch cover may not be attached.

## 10. Adjusting the timing belt tension

### 10-1. Timing belt X

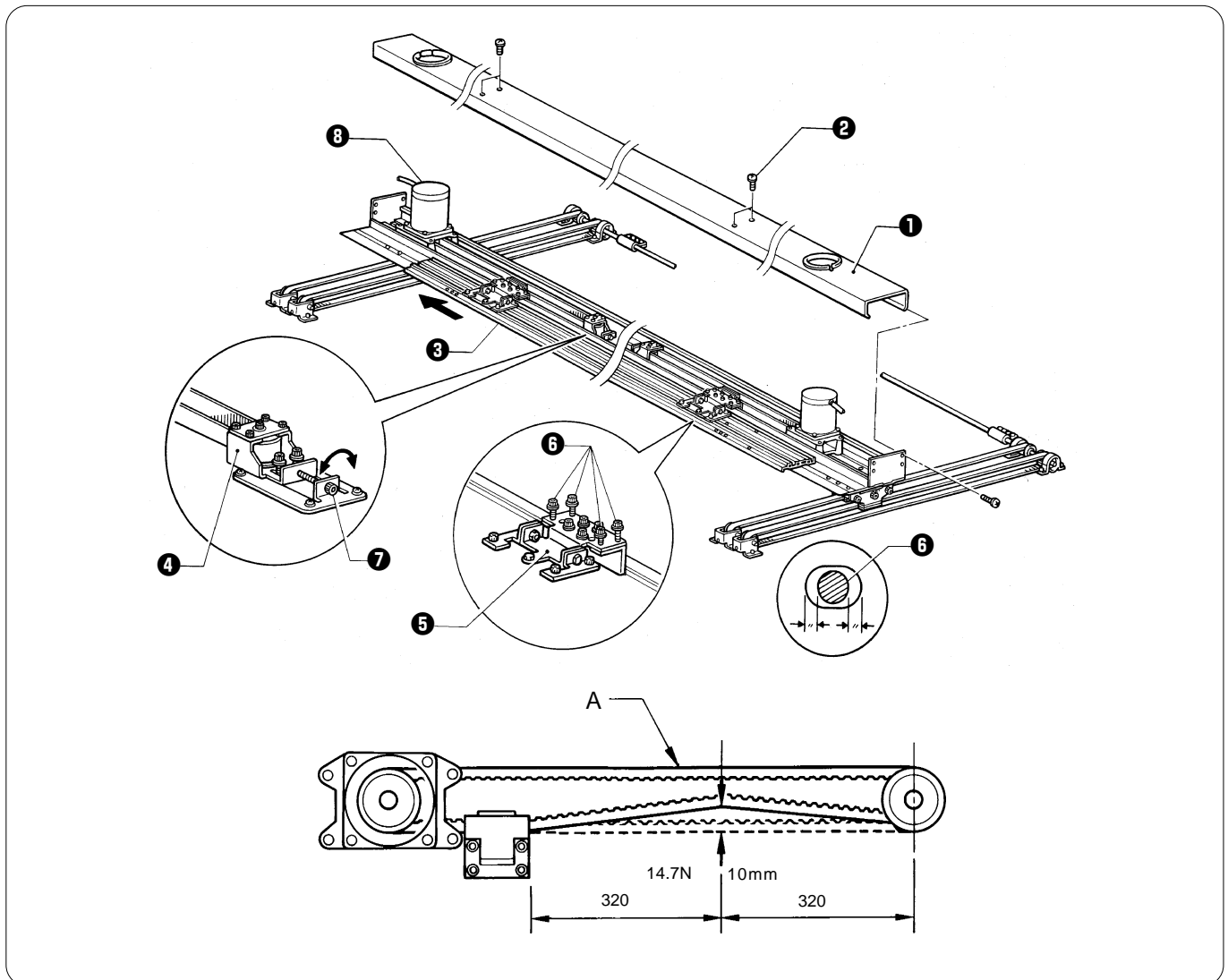

1. Remove the screws ②, and the X-feed cover ①.
2. Move the X-feed frame ③ all the way towards the pulse motor.
3. Loosen the two screws of X-pulley bracket B ④ and the four screws ⑥ of the X-feed bracket ⑤.
4. Turn the adjusting screw ⑦ to adjust the belt tension.  
Clockwise: Tension will be increased.  
Anti-clockwise: Tension will be decreased.
5. Tighten the screws of X-pulley bracket B ④ and the X-feed bracket ⑤. Adjust the belt tension so that the slack will be approx. 10 mm with a load of 14.7 N (1.5 kgf) applied to the place indicated by the arrows as shown in the above figure.
6. Turn on the power to magnetize the X motors ⑧ on both sides. Secure the X-feed bracket ⑤ using the screws ⑥ so that they are in the center of each hole. Secure another X-feed bracket ⑤ in the same way.

Note:

The screws ⑥ should be central in every hole.

When measuring the slack using a sonic tension meter manufactured by Unitta Inc., input the following:

Weight: 4.0

Width: 20

Span: 806

When measuring at point A

Adjust the belt tension so that a sonic tension meter applies  $21 \pm 1$  kgf to the belt when it bounces at point A. At this time, nothing should be making contact with the belt.

## 10-2. Timing belt Y

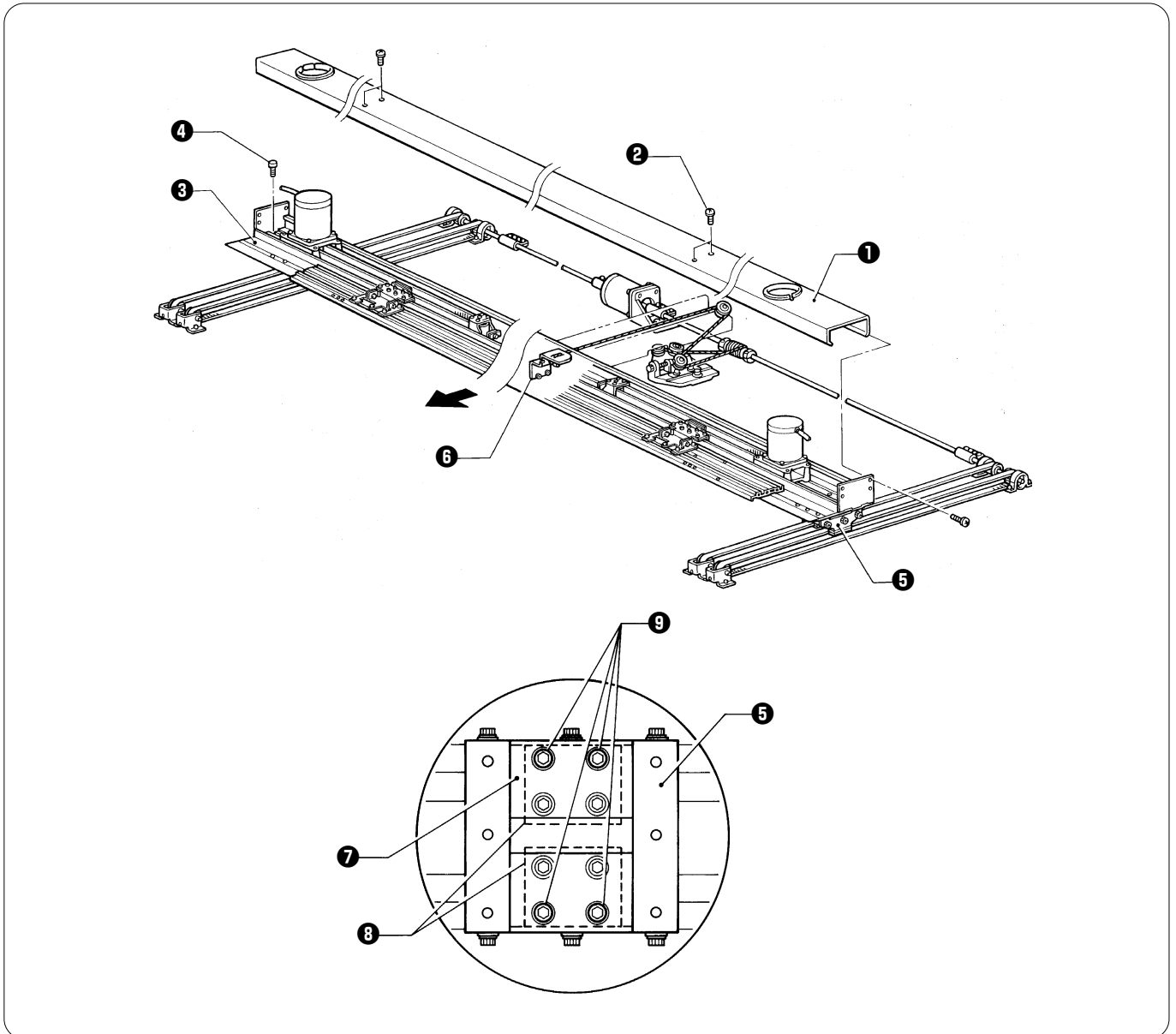

1. Remove the screws **2** and the X-feed cover **1**.
2. Remove the 13 screws **4** from the Y-feed frame **3**. Remove the Y-feed frame **3** from the Y carriage **5** and the rail connecting plate **6**, and shift the Y-feed frame **3** toward the front.
3. Viewed from the top of the Y carriage **5**, loosen the 16 bolts **9** of the timing belt setting plate **8** from the holes of the Y carriage **7**. (Do not remove them.)

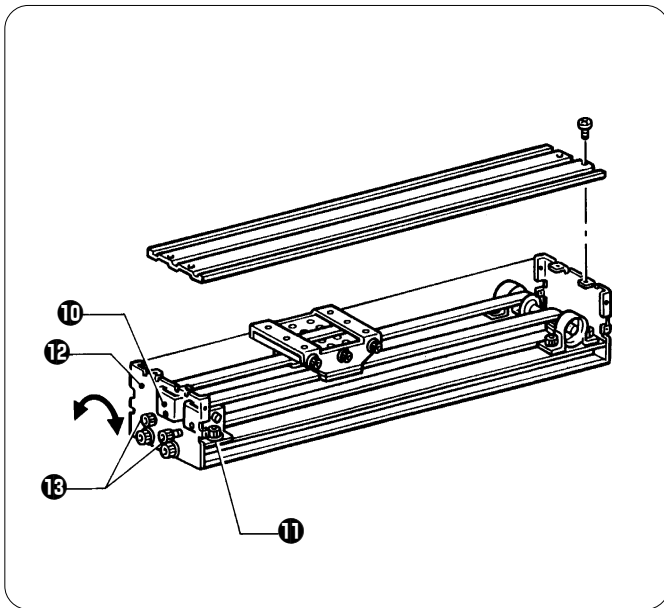

4. Loosen the eight bolts 11 securing the Y pulley bracket 10.
5. Turn the tension adjusting bolts 13 of the Y-feed cover support plate 12 to adjust the belt tension.

Clockwise: Tension will be increased.  
 Anti-clockwise: Tension will be decreased.

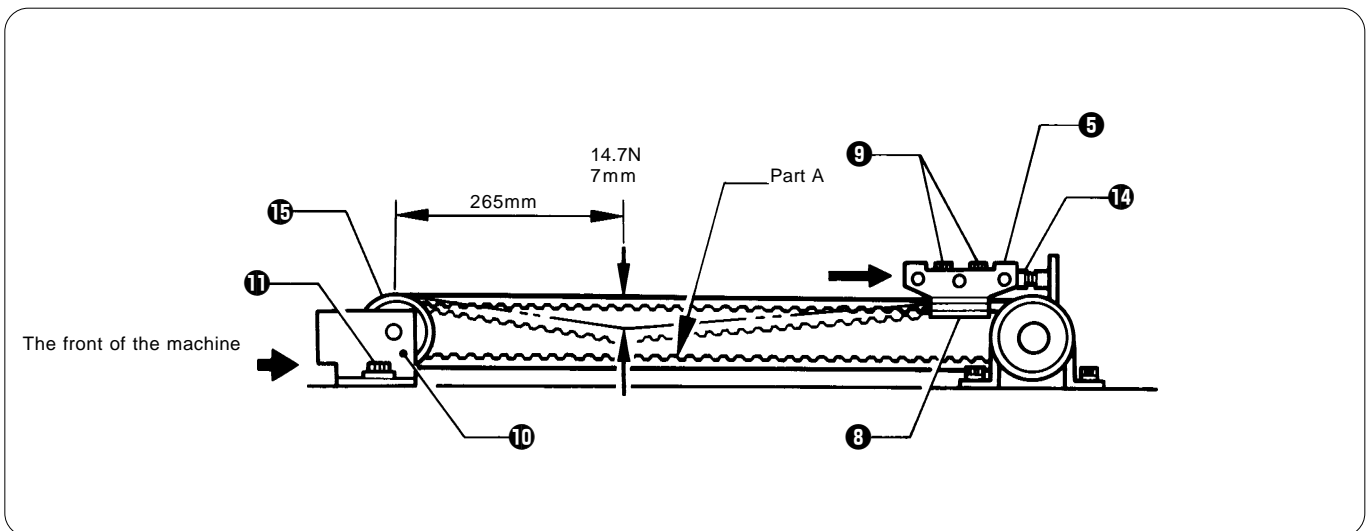

6. Move the Y carriage 5 all the way backward (from the front of the machine) until it makes contact with stopper R 10.
7. Tighten the screws 9 of the timing belt setting plate 6 which is on either timing belt Y to be measured. Apply a load of 14.7 N (1.5 kgf) to the position 265 mm away from the pulley 10 at the front, and adjust the belt tension so that the slack will be approx. 7 mm.

Note:

Do not adjust the belt tension when the timing belt setting plates on both sides are secured.

When measuring the slack using a sonic tension meter manufactured by Unitta Inc., input the following:

Weight: 4.0

Width: 20

Span: 640

When measuring at point A

Adjust the belt tension so that a sonic tension meter applies  $21 \pm 1$  kgf.

Note:

Before measuring the slack of the belt, tighten the eight bolts 11 securing the Y-pulley bracket 10.

8. After adjusting the tension of the four belts, tighten the bolts 9 of the timing belt setting plate 6.

Note:

After replacement, make sure that Y-feed resistance is 15 kgf with the tubular frame on, and 16 kgf with the cap frame attachment on. If the resistance is too great, adjust the Y carriage.



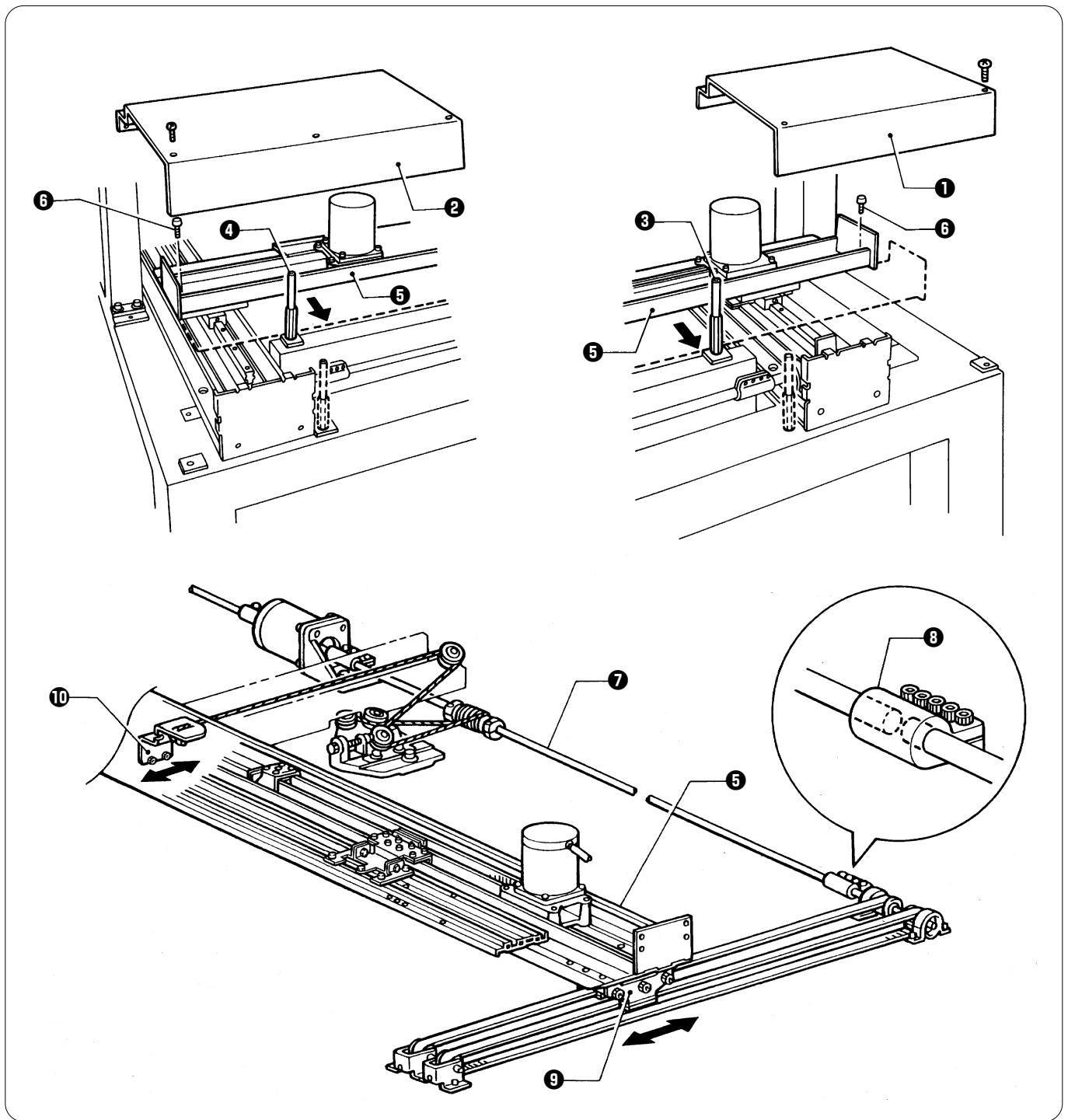

**Positioning Y-feed frame (Perform from the rear of the machine.)**

1. Remove the screws, and table covers L **1** and R **2**.
2. From the back of the frame, reinsert post LB **3** that is the third from the left, and post LB **4** that is the third from the right, into the extreme left and right holes on the second steel tube, respectively.
3. Press the Y-feed frame **5** against posts LB **3** and **4** and secure it using the 13 screws **6**.
4. Return posts LB **3** and **4** to their previous positions.

Note:

When the Y-feed frame **5** is secured and the screw holes do not match, loosen the bolts of coupling 15 **8** connected to the connecting shaft **7**, and move the Y carriage **9** or the rail connecting plate **10** back and forth to adjust the positions of the screw holes.

## 11. Adjusting the driving wire

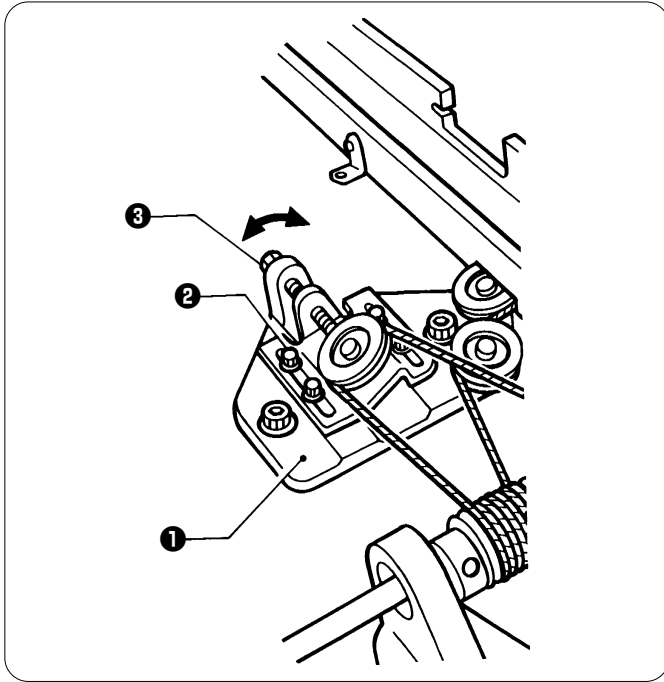

1. Loosen the four bolts **2** of the pulley base **1**, and turn the bolt **3** to adjust the wire tension.

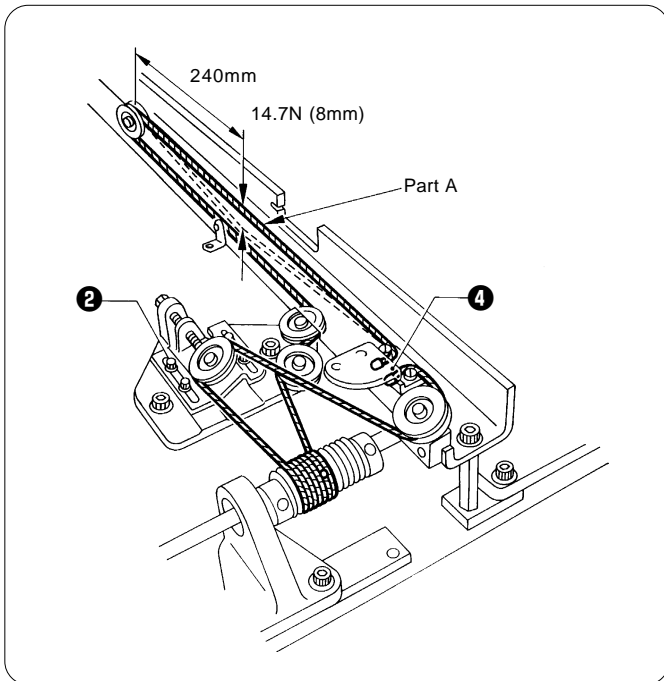

2. Move the rail connecting plate **4** all the way backward (viewed from the front), and adjust the wire tension so that the slack will be approx. 8 mm with a load of 14.7 N (1.5 kgf) applied to the position 240 mm away from the pulley at the front.

Note:

Before measuring the slack, tighten the four bolts **2** to secure the pulley base.

When measuring the slack using a sonic tension meter manufactured by Unitta Inc., input the following:

Weight: 19.1

Width: 1

Span: 480

When measuring at point A

Adjust the belt tension so that a sonic tension meter applies  $21 \pm 1$  kgf to the belt.

Note:

After replacement, make sure that Y-feed resistance is 15 kgf with the tubular frame on, and 16 kgf with the cap frame attachment on. If the resistance is too great, adjust the Y carriage.

## 12. Adjusting the Y-carriage

The sliding resistance of the Y carriage with the tubular frame on is 147 N (15 kgf), and with the cap frame attachment on, 157 N (16 kgf). If the measured sliding resistance is greater than these standard values, adjust the Y carriage as follows:

How to measure the sliding resistance of the Y carriage

- Using a push-pull gauge, slowly press the place where the Y-feed frame ❶ makes contact with the Y carriage ❷ in the direction of the arrow, and measure the sliding resistance of the Y-carriage for all of its stroke. (Compare the maximum measured sliding resistance to the standard value.)

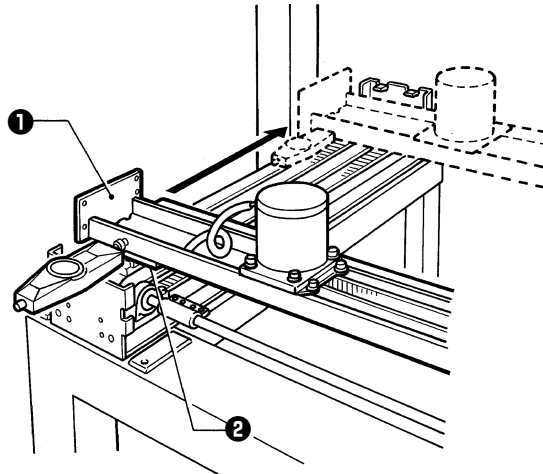

- If the Y-carriage movement is impeded, perform the following adjustments starting with step 1 until the resistance is equal to the standard value.
- If the Y carriage gradually becomes impeded as it is moved from the back to the front or in the latter half of the movement to the front, perform step 4.

Note:

After each adjustment, do not fail to measure the sliding resistance of the Y carriage in the manner described above.

- Remove the X-feed cover ❸ and the button head screws ❹ to separate the Y-feed frame ❺ and the rail connecting plate ❻, and measure the resistance of the Y-carriage ❼.

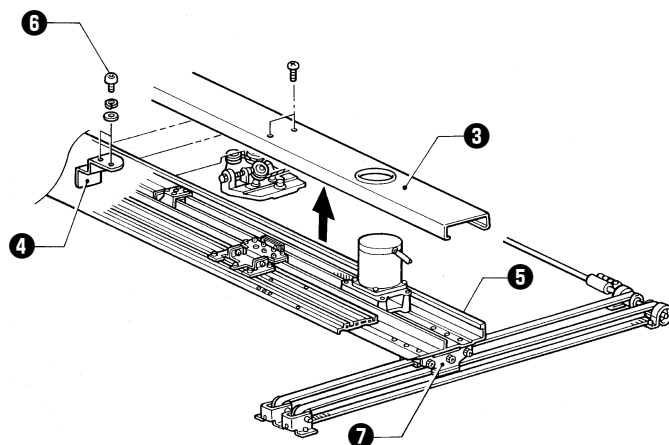

## 12-1. When the sliding resistance of the Y-carriage is below the standard value

Check the clearance between the Y-feed frame **3** and the rail connecting plate **2**.

When there is no clearance

Move the Y-feed frame **3** as close as possible to the needle plate side when viewed from the rear of the machine, and tighten the button head screws **4**.

Note:

When a button head screw can not be inserted into a hole in the rail connecting plate **2**, move the Y-feed frame **3**, temporarily insert another button head screw into the hole, and securely tighten the button head screw which is on the needle plate side.

When there is clearance

Insert the washer **6** between the Y-feed frame **3** and the rail connecting plate **2**, and tighten the button head screws **4** and the spring washers **7**.

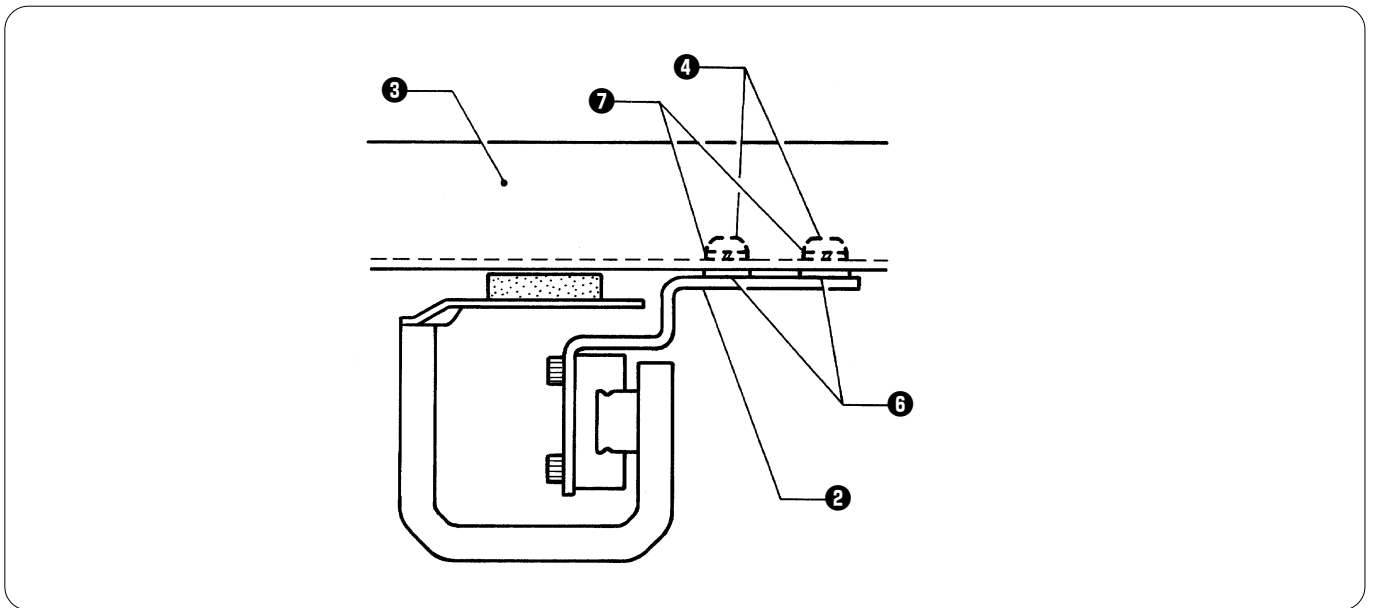

- After adjustment, measure the sliding resistance of the Y-carriage again. If the measured resistance is still not equal to the standard value, perform step 2.

## 12-2. When the sliding resistance of the Y-carriage is over the standard value

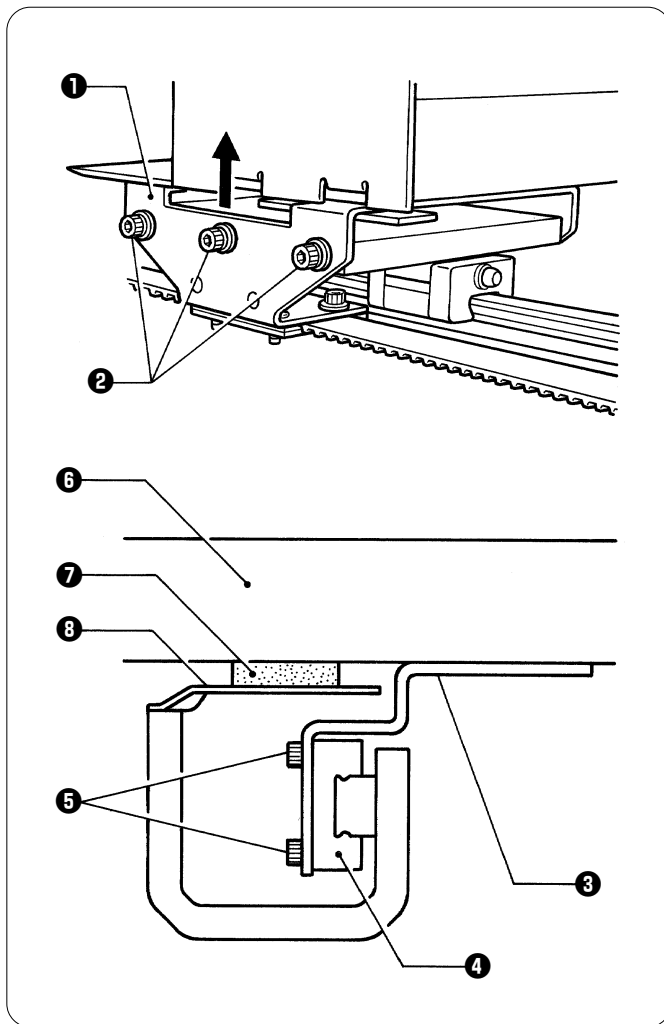

- Loosen the bolts ② on both sides of the Y-carriage ①, raise the Y-carriage ① to adjust the clearance between the Y carriage ① and the Y-feed frame, and retighten the bolts ②.
- Loosen the bolts ⑤ to separate the rail connecting plate ③ and the linear guide ④, raise the rail connecting plate ③ so as not to leave a gap between the felt ⑦ on the back of the Y-feed frame ⑥ and the bed cover ⑧, and then retighten the bolts ⑤.

**Note:**

When the position of the rail connecting plate ③ is changed as described above, the clearance between the tubular frame and the needle plate may become greater, resulting in the needle plate rattling during sewing. Do not raise the front (the needle plate side) of the rail connecting plate ③ too much.

- After this adjustment, measure the sliding resistance of the Y-carriage again. If it is still over the standard value, make adjustment written in 12-3.

## 12-3. When the sliding resistance of the Y-carriage is over the standard value even after adjustment 2

Remove both Y-feed covers U ❶, measure the sliding resistance of the Y-carriage again. If the sliding resistance becomes less, check the following items:

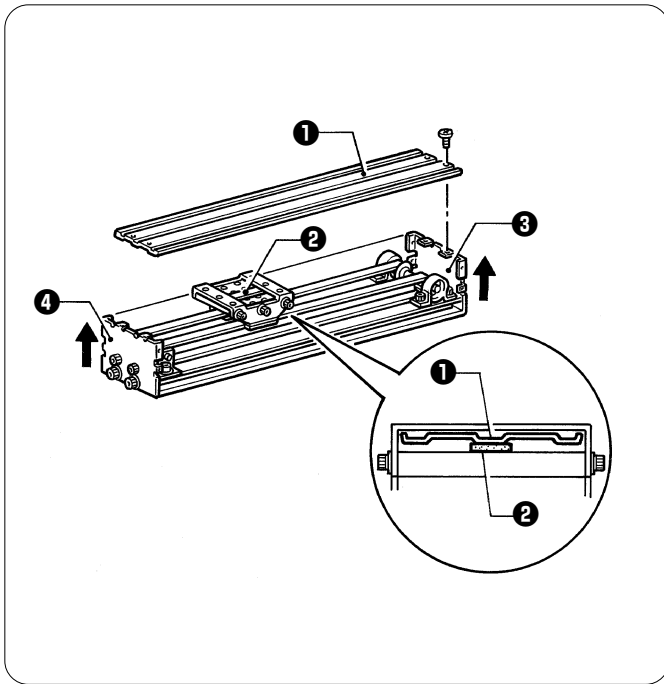

- Check if Y-feed covers U ❶ that hold spacer felt ❷ down are deformed. If they are, straighten them.
- When the sliding resistance becomes great before and after the Y-carriage, reattach the Y-feed cover support plates ❸ and ❹ as high as possible.

### Notes:

- If Y-feed cover U is raised too much, it may creak during sewing. Do not change its position more than necessary. (To prevent vibration, have the Y feed cover U just make contact with the Y carriage.)
- Finish adjustments 1 to 3 when the sliding resistance is equal to the standard value. There is no need to perform all adjustments.

## 12-4. When linear guide 505L, which is attached to machine head No.3, is not parallel to the top surface of the bed

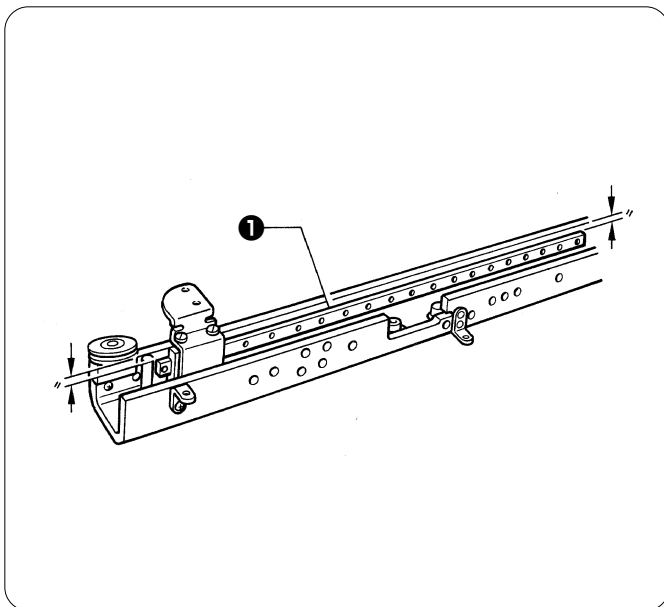

- Loosen the bolts of linear guide ❶, move the Y-feed frame to adjust the height of linear guide 505L ❶ at both ends of the stroke. (The felts should just touch the top surface of the bed.)

## 13. Adjusting the rotary encoder and sensor PCB

- The rotary encoder and sensor PCB is used to detect the needle stop position and synchronize hoop motion.
- When the machine stops after thread trimming or is stopped for an emergency during sewing, the needle bar is in the jump condition (stopped in the raised position), and its thread take-up stops at the same position as the other eight.

### 13-1. Adjusting the machine stop position signal

Use the [ECd] test mode on the operation panel.

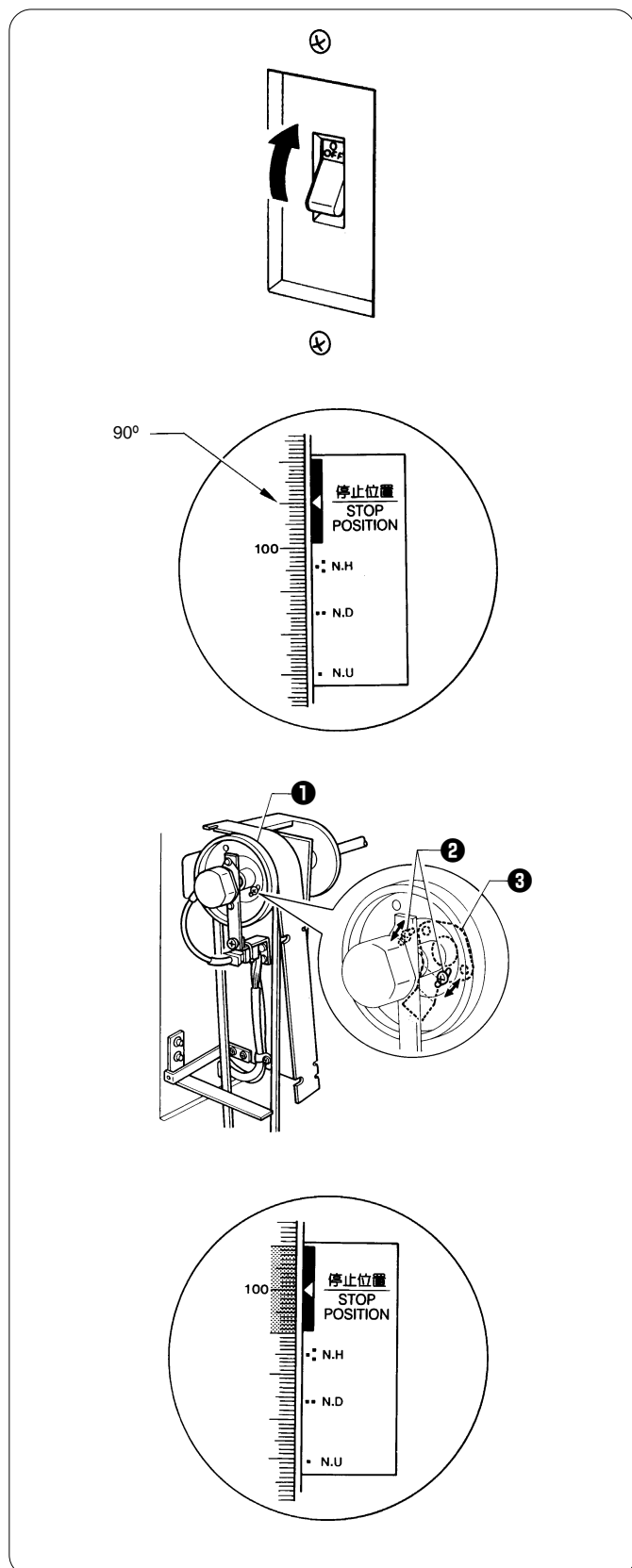

1. Turn on the power, and select the [ECd] test mode on the operation panel.  
Refer to page 76, "Test mode" for details.

2. Turn pulley B ❶ in the rotation direction until the stop position mark on the pulley indicates 90 degrees on the belt.

At this time, the buzzer should beep. Loosen the screws ❷ to adjust the position of the dog ❸.

- \* When pulley B is turned 90 - 110 degrees, a correctly adjusted stop position signal outputs "U-H," or "U-L" on the panel.

## 13-2. Adjusting the synchronizing signal

Use the [ECd] test mode on the operation panel.

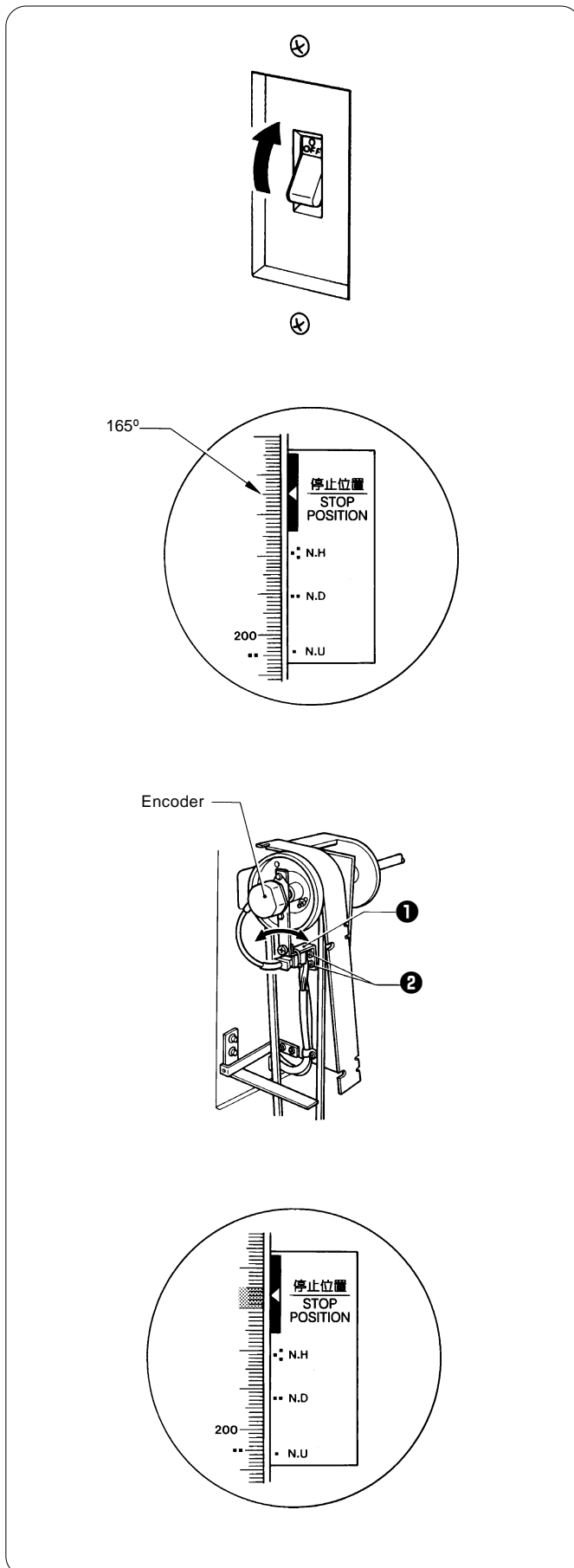

1. Turn on the power, and select the [ECd] test mode on the operation panel.  
Refer to page 76, "Test mode" for details.

2. Turn the pulley in the rotation direction until the stop position mark on the pulley indicates 165 degrees on the belt.  
At this time the buzzer should beep. Loosen the screws ② to adjust the angle of the encoder adjustment plate ①.

\* When the pulley is turned 165 - 170 degrees, a correctly adjusted stop position signal outputs "-dL," or "-dH" on the panel.



## 14. Adjusting the bobbin winder

### 14-1. Positioning the bobbin winder claw

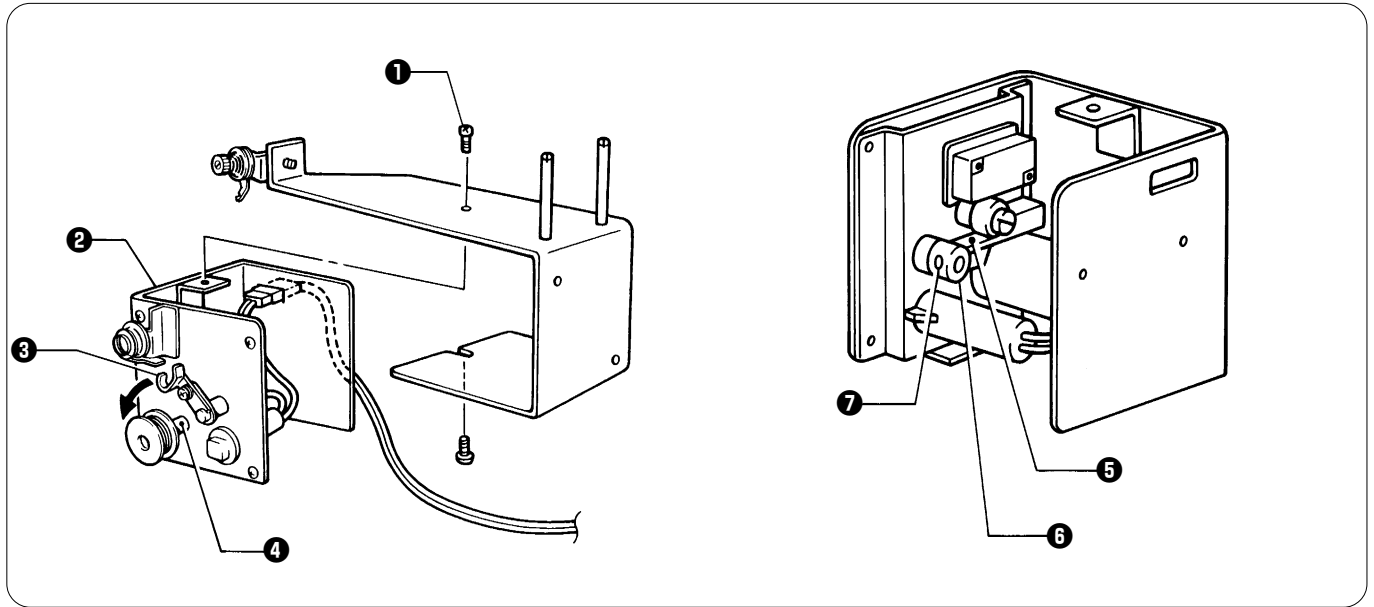

1. Remove the two screws ①, and the bobbin winder set ②.
2. Move the bobbin presser ③ toward the bobbin winder shaft ④ just before it reaches the position where thread winding ends.
3. Tighten the two screws ⑦ so that the spring plate ⑤ is at the stepped section of the bobbin winder claw ⑥.

### 14-2. Positioning the bobbin presser

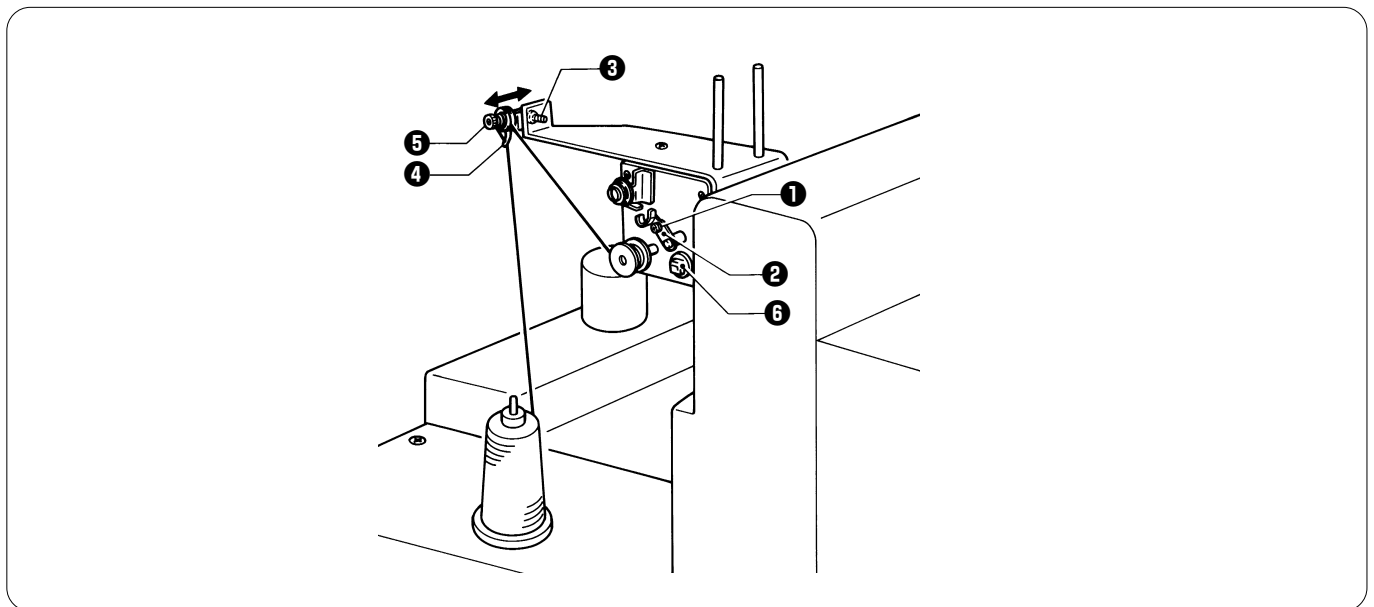

Loosen the screw ①, and adjust the bobbin presser ② by moving it so that the proper amount of thread can be wound on the bobbin.

**Notes:**

- If the thread is not wound evenly on the bobbin, loosen the screw ③, and move the thread guide ④ to the right and left. To wind more thread on the bobbin, loosen the screw ①, and move the bobbin presser ②.
- If the thread comes out of the thread guide ④, loosen the knob ⑤. If the thread is wound too loose, tighten the knob ⑤.
- The bobbin winder motor does not operate if the circuit protector ⑥ has tripped. In such a case, leave the circuit protector until it has cooled off, then reset it. (If the protector is not left to cool off and you reset it by pressing it, the protector will immediately trip again.)

## 15. Adjusting the wire of the cap frame attachment

### 15-1. Adjusting the wire tension

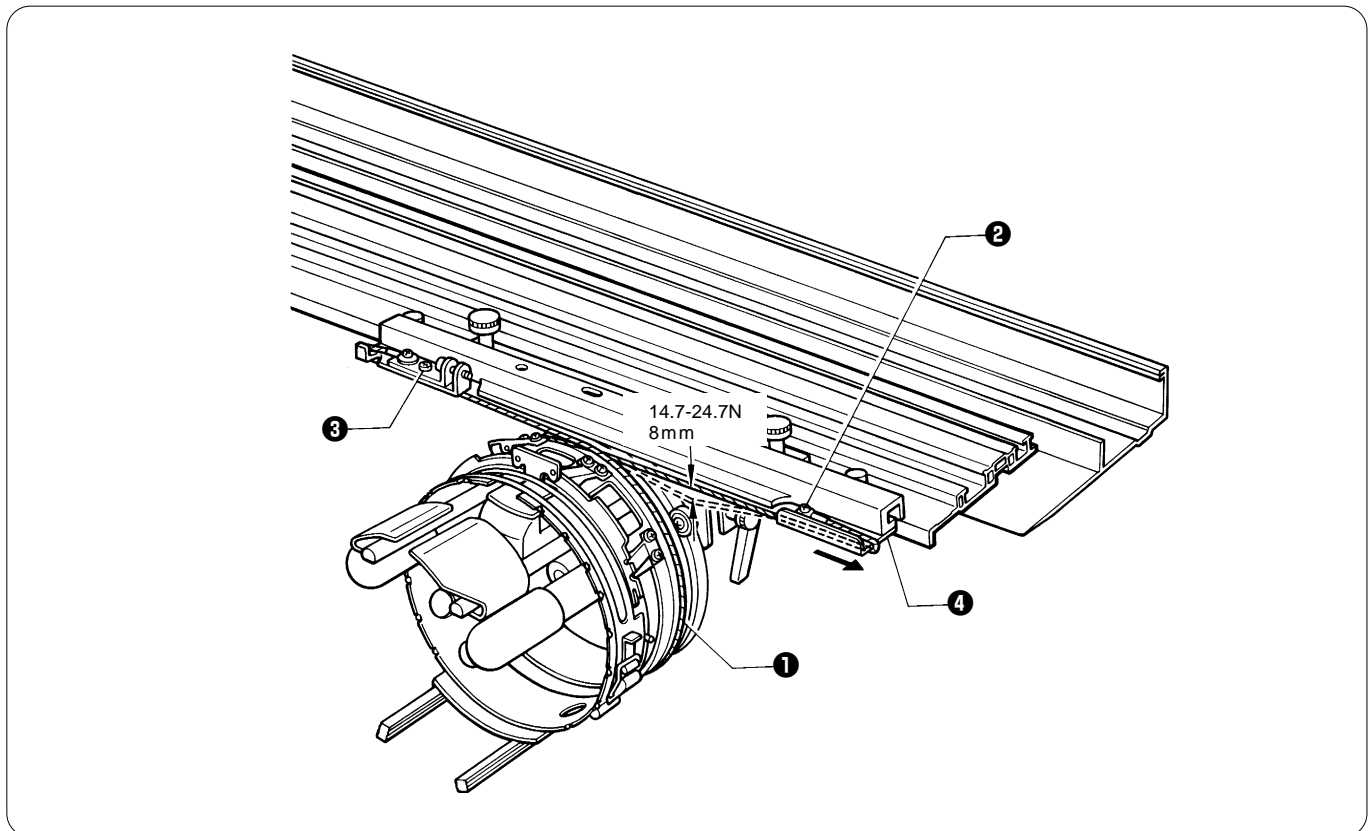

1. Loosen the screw ③, and adjust the wire tension ① by tightening the screw ② so that the wire is equally tensioned at each end.
2. After adjustment, tighten the screw ③.
3. Move the wire base ④ to either side. Adjust the wire tension so that the slack will be 8 mm with a load of 14.7 - 24.7 N (1.5 - 2.5 kgf) applied to the middle of the wire ①, as shown in the figure.

## 15-2. Adjusting the feed roller

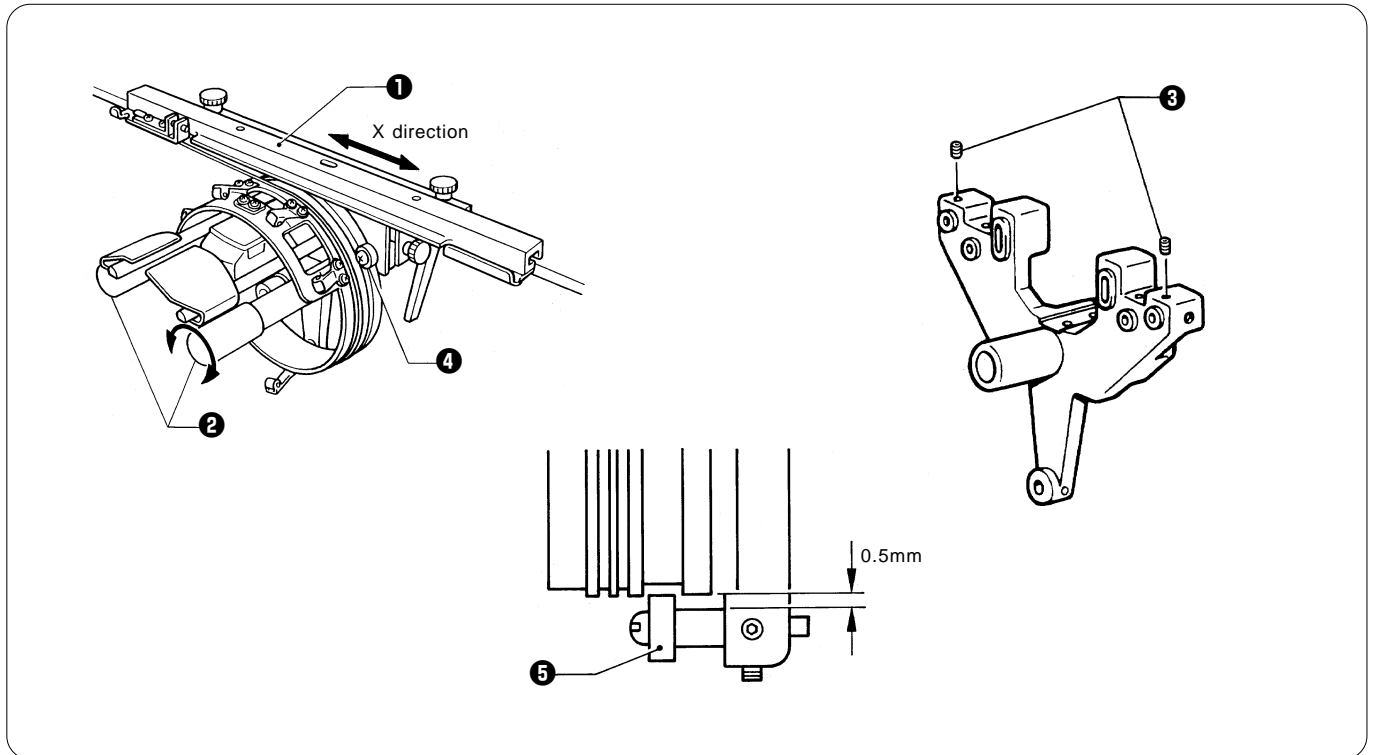

When the cap frame sash ① moves in the X direction, make sure that the feed roller ② turns. If it does not turn, loosen the two set screws ③ and retighten the bearings ④ on both sides. (Make sure that there is a 0.5 mm clearance for the bearing ⑤.)

## 15-3. Adjusting cap support plates L and R

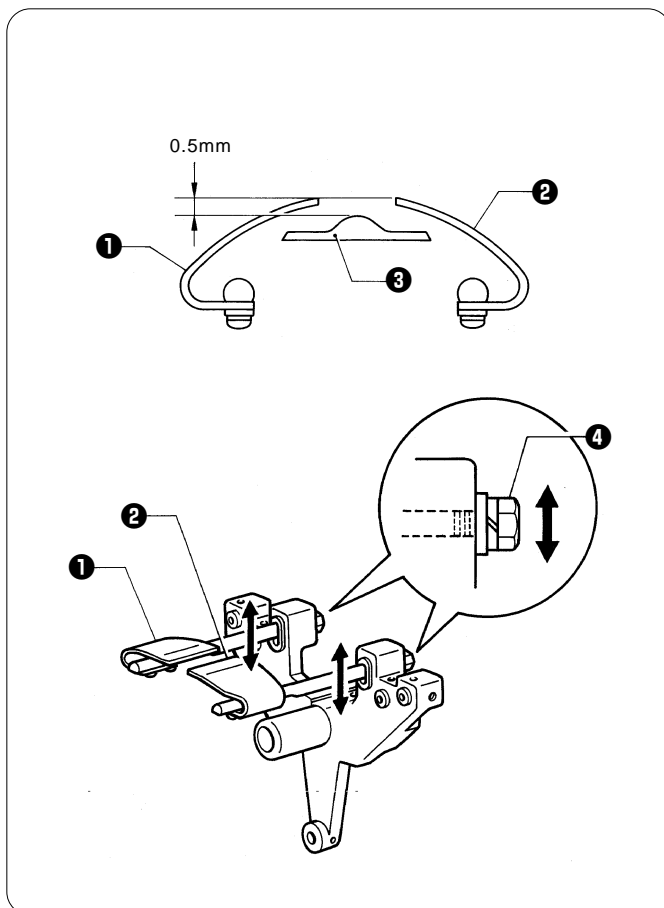

Loosen the nut ④, and move cap support plates L ① and R ② up and down to adjust their heights 0.5 mm above the top of the needle plate ③.

## 15-4. Adjusting the presser foot height

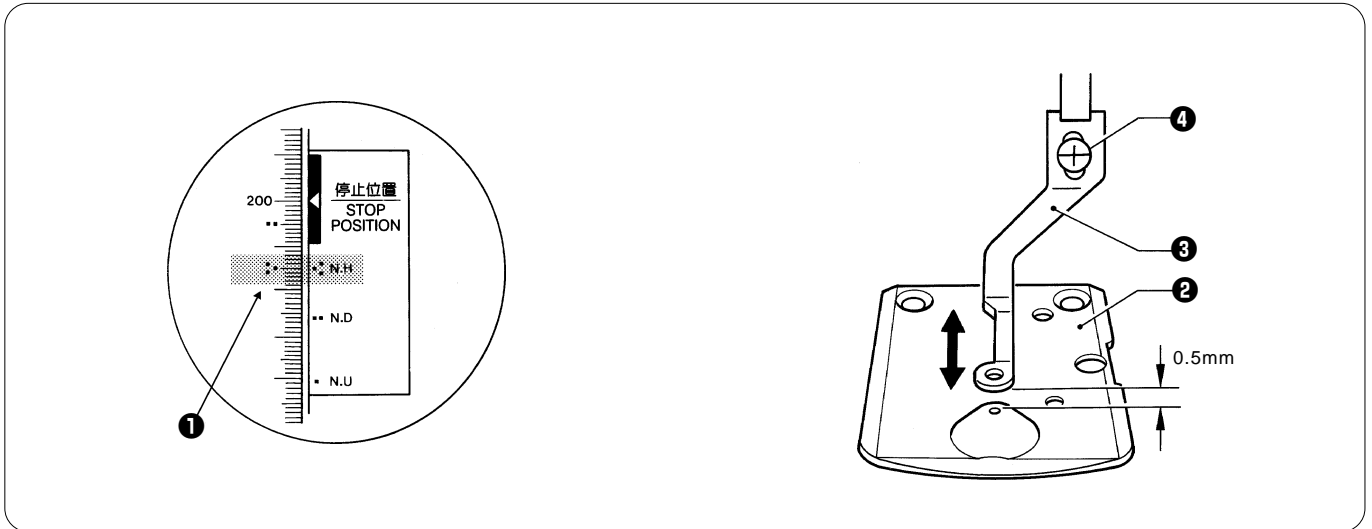

1. Turn the pulley ① until the "■" mark on the pulley ① is aligned with the "■" mark on the belt cover.
2. Loosen the screw ④, and adjust the presser foot height by moving it up and down so that there is a 0.5 mm clearance between the needle plate ② and the presser foot ③.

# Chapter 4 Test mode

[Test mode on the operation panel]

## 1. Starting test mode

With the PC in standby mode, press the STOP switch and jog switch ( $\Delta$ ). "tcut" appears in the window (7 segment LED), and the machine controller will enter test mode 1.

With the machine stopped, press the STOP switch and jog switch ( $\nabla$ ). "AJSt" appears in the window (7 segment LED), and the machine controller will enter test mode 2.

## 2. Selecting test mode menu

Jog switches ( $\leftarrow$ ,  $\rightarrow$ ) are used to indicate test mode menus from "tcut" to "A\_go" on the 7 segment LED.

In test mode 2, only "AJSt" (rotary hook meeting point adjustment) menu appears.

tcut	: Thread trimmer adjustment
CASE	: Needle bar case test
org	: Home position searching test
Ecd	: Encoder signal test
diSP	: Switches and LEDs test (operation panel and machine head)
Foot	: Presser foot test
SOL	: Solenoid test
FEEd	: Driving shaft rotation test
PLUS	: Stitch compensation
AJSt	: Rotary hook meeting point adjustment
PH-P	: Program version indication for heads and operation panel
AC	: Power voltage and frequency indication
Port	: Port check
7LEd	: 7 segment LED indication test
HEAd	: Machine head communication test
bEEP	: Error sound switching
A_go	: Automatic start at the end of mending

- Select a test item and press the START switch. The selected test starts.
- When the stop switch is pressed while any test item from "tcut" to "A\_go" is indicated on the 7 segment LED, the machine controller exits the test mode and returns to the previous condition before the test mode.
- "A\_go" does not appear when the PC controller is equipped with the automatic start function at the end of mending.

## 3. Test mode functions

### 3-1. Thread trimmer adjustment

1. Indication "tcut" will blink on the 7 segment LED, and the head will be ready for adjustment of the thread trimmer. (Refer to "Adjustment of Thread Trimmer" in BES-960BC instruction manual.)
2. Press the STOP switch after the thread trimmer has been adjusted.
3. Indication "tcut" on the 7 segment LED, which was blinking, will return to its usual status.

### 3-2. Needle bar case test

1. The 7 segment LED shows "\*\*-?."

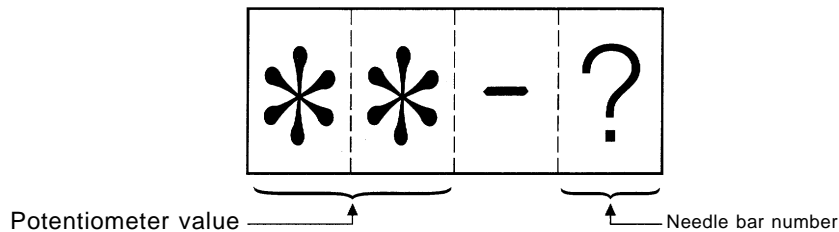

2. Press the left switch to change the needle bar to the next toward needle bar no.9 (for nine needles).

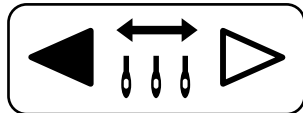

3. Press the right switch to change the needle bar to the next toward needle bar no.1.

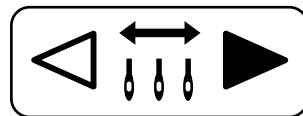

**Note:**

When the needle bar case is positioned at needle bar no.1 (standard position) and "19-1" appears on the display, the buzzer will beep.

If the buzzer does not beep, adjust the potentiometer so that buzzer will beep when the needle bar case is at needle bar no.1 and "19-1" appears on the display.

4. Press the check switch to display S-\*\* on the 7 segment LED. Change needle bar movement speed.
  - \*\* is a number that will be determined as a parameter of speed when the needle bar case moves; the number can be set from 5 (fastest) to 30 (slowest).
  - Jog switch ( $\triangle$ ) is used to decrease needle bar case speed parameter number one by one and increase movement speed.
  - Jog switch ( $\nabla$ ) is used to increase needle bar case speed parameter number one by one and decrease movement speed.
  - When the start switch is pressed, "1-9" (for nine needles) will appear on the 7 segment LED, and the needle bar case endurance test will start. Press the stop switch to finish the test.
  - When the thread trimming switch is pressed, "1-9" (for the BES-960) will appear on the 7 segment LED, and the thread trimming test will start. Press the stop switch to finish the test.
  - When the stop switch is pressed, the machine controller will return to the needle bar case test mode.
5. After needle bar case test, press the stop switch. Indication "CASE" will appear on the 7 segment LED.

### 3-3. Home position searching test

1. The 7 segment LED shows "C-F."
2. Press jog switch (▷) or (◁).  
 (▷): The 7 segment LED shows "FLA" with 3 beeps and the frame moves to the holder base frame home position.  
 (◁): The 7 segment LED shows "CAP" with 3 beeps and the frame moves to the cap frame home position.
3. Press the STOP switch to finish home position searching test. The 7 segment LED will show "Org."

### 3-4. Encoder signal test

1. In the range of the needle up stop position (while the indicator on the pulley is in the range from 90 degrees to 110 degrees), turn the pulley. The buzzer will beep and "U-\*" will appear on the 7 segment LED.

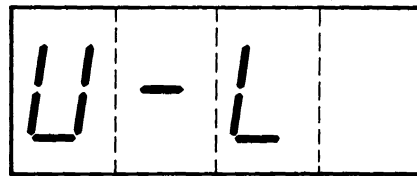
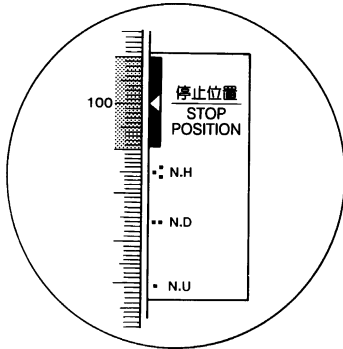

"H" or "L" will appear here.

2. In the range of the synchronizing signal (while the indicator on the pulley is in the range from 165 degrees to 170 degrees), turn the pulley. The buzzer will beep and "-d\*" will appear on the 7 segment LED.

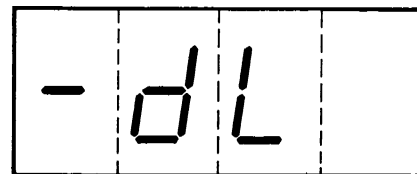
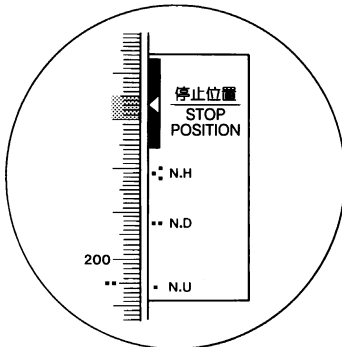

"H" or "L" will appear here.

**Note:**

"\*" will be "H" or "L" alternatively while the pulley rotates, it depending on the angle of the pulley.

3. Press the stop switch to finish the encoder signal test. "Ecd" will appear on the 7 segment LED.

### 3-5. Switch and LED test on operation panel and head

1. Indication "DISP" will blink on the 7 segment LED.
2. Set each of drive switch, mending switch, and step forward/backward switch as follows to test their LEDs.

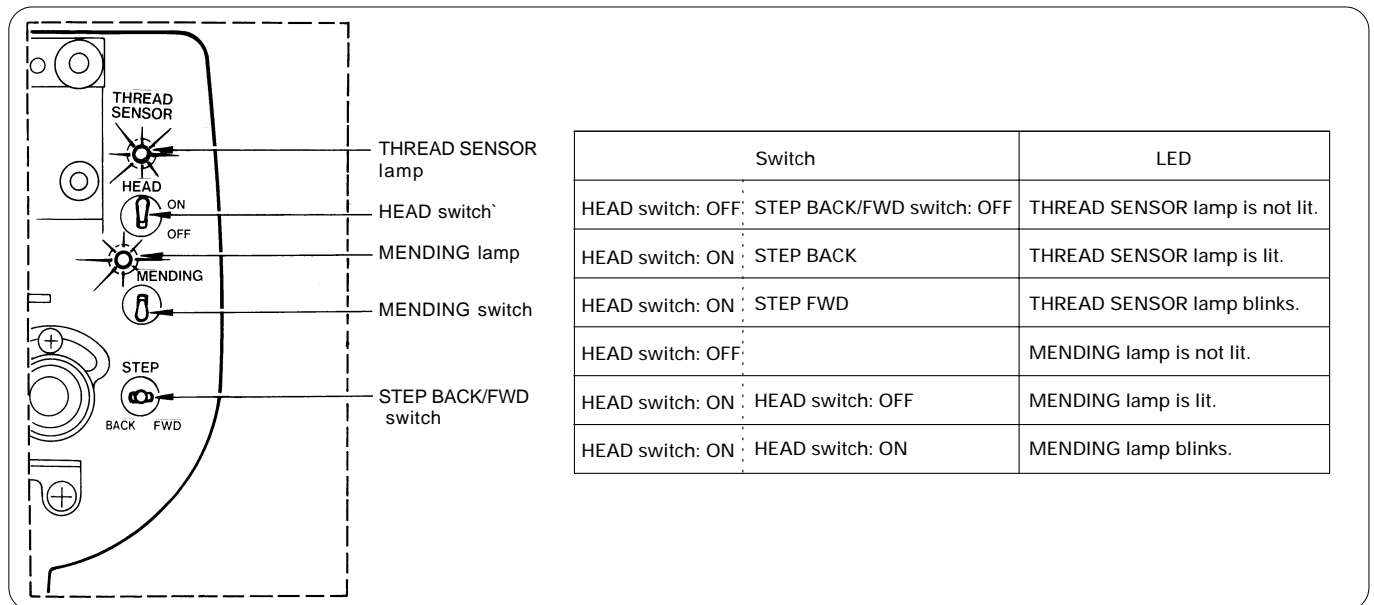

3. Press the start switch. The numbers from 10 to 1500 appear in order in multiples of 10.

Note:

If the test is finished halfway, press the stop switch.

4. Press the check switch to test switches. When a switch is pressed, the indication on the 7 segment LED will vary as follows:

No switch pressed:	"P-FF"
[Start] switch:	"P-0A"
[Stop] switch:	"P-0b"
[Thread trimming] switch:	"P-41"
[Hoop feed] switch:	"P-40"
[Needle bar change: left]:	"P-44"
[Needle bar change: right]:	"P-43"
[left] switch:	"P-05"
[right] switch:	"P-04"
[up] switch:	"P-06"
[down] switch:	"P-07"

5. Press the stop switch twice to finish the switch and LED tests. The indication "DISP" on the 7 segment LED, which was blinking, will return to its usual status.



## 3-6. Presser foot test

1. With "Foot" indicated on the 7 segment LED, press the start switch. The presser feet of all heads will be lowered and "F-00" will appear.

Note:

"\*\*" of "F-\*\*" shows the status of the presser foot sensor on each head using a hexadecimal number.

The 7 segment LED shows for example:

"F-20" when the presser feet of head 6 are raised using the manual lever.

"F-10" when the presser feet of head 5 are raised using the manual lever.

"F-08" when the presser feet of head 4 are raised using the manual lever.

"F-04" when the presser feet of head 3 are raised using the manual lever.

"F-02" when the presser feet of head 2 are raised using the manual lever.

"F-01" when the presser feet of head 1 are raised using the manual lever.

2. Press the jog switch ( $\Delta$ ). The presser feet of all heads will be raised, and "F-3F" will appear on the 7 segment LED with a buzzer sounding.

Note:

When the indication is not "F-00," the buzzer will beep.

3. Press the jog switch ( $\nabla$ ). The presser feet of all heads will be lowered, and "F-00" will appear.

4. Press the stop switch to finish the presser foot test. "Foot" will appear on the 7 segment LED.

## 3-7. Solenoid test

1. With "SOL" indicated on the 7 segment LED, press the start switch. The presser feet of all heads will be lowered, and "F-00" will appear on the 7 segment LED.

Note:

"\*\*" of "S-\*\*" shows the status of the wiper sensor on each head using a hexadecimal number.

The 7 segment LED shows for example:

"F-20" when the wiper of the head 6 only is advanced.

"F-0" when the wiper of the head 5 only is advanced.

"F-08" when the wiper of the head 4 only is advanced.

"F-04" when the wiper of the head 3 only is advanced.

"F-02" when the wiper of the head 2 only is advanced.

"F-01" when the wiper of the head 1 only is advanced.

2. Press the jog switch ( $\Delta$ ), the check switch, or the hoop feed switch to execute the following functions:

Jog switch ( $\Delta$ ): Operates the wiper solenoid once.





Check switch: Repeats operation of the jump solenoid. (Press the stop switch to finish it.)

Hoop feed switch: Keeps the jump solenoid activated.

3. Press the stop switch to finish the solenoid test. "SOL" will appear on the 7 segment LED.

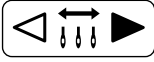
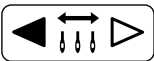
## 3-8. Driving shaft rotation test

1. Press either of the following switches to set the rotation of the driving shaft:

Switch	Description
Needle bar change left switch 	Sets rotation speed to +50. (Can increase up to 1200.) The set rotation speed will appear on the 7 segment LED.
Needle bar change right switch 	Sets rotation speed to -50. (Can decrease to 1000.) The set rotation speed will appear on the 7 segment LED.
Jog switch 	Do not press these keys during this test.
Jog switch 	Do not press these keys during this test.
Thread trimming switch 	Do not press these keys during this test.
Check switch 	Do not press these keys during this test.

2. Press the jog switch (right) or (up) or the hoop feed switch to rotate the driving shaft.

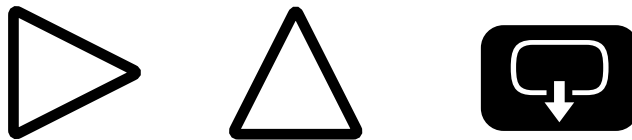

The driving shaft will rotate and can be stopped using the stop switch.



## 3-9. Stitch compensation

Stitch compensation can be set in increments of 0.1 mm from 0.0 mm to 1.0 mm.

The set stitch compensation value is kept memorized in a program even when the power of the machine is turned off. It is unnecessary to set it again every time the power is turned on.

1. With the machine in standby mode, press the stop switch and the jog switch (up) to enter the test mode.

Note:

This function can be used as long as the machine is in standby mode.

2. Press the jog switch (right) to select "PLUS" from the test menu.

3. While sewing is suspended, stitch compensation can not be changed.

4. Press the start switch. "XXYY" will appear on the 7 segment LED.  
XX: X stitch compensation value  
YY: Y stitch compensation value
5. Use the jog switches to set the stitch compensation value as follows:  
Jog switch (◀): Decreases the X stitch compensation value in increments of 1 (0.1 mm) (Min. 0)  
Jog switch (▶): Increases the X stitch compensation value in increments of 1 (0.1 mm). (Max. 10)  
Jog switch (▽): Decreases the Y stitch compensation value in increments of 1 (0.1 mm) (Min. 0)  
Jog switch (△): Increases the Y stitch compensation value in increments of 1 (0.1 mm). (Max. 10)
6. After the stitch compensation has been completed, press the stop switch. "PLUS" will reappear on the 7 segment LED.
7. Press the stop switch again to exit the test mode.  
Note:  
If the stitch is compensated too much, the pattern shape may be deformed. Confirm the finished pattern and compensate the stitch appropriately.

### 3-10. Adjusting the timing between the needle and the rotary hook

1. Select "AJSt" test mode, and press the start switch. "StEP" will appear on the 7 segment LED, and all rotary hooks will rotate until their specified meeting points.
2. Using the step forward/backward switch on the head, adjust the meeting point as follows:  
Step forward switch: Rotates the rotary hook clockwise by inching.  
Step backward switch: Rotates the rotary hook anti-clockwise by inching.
3. After adjustment for all rotary hooks has been completed, press the stop switch. "AJSt" will appear on the 7 segment LED.

Note:

When this adjustment has been performed in test mode 2, the test mode ends.

As to the details, refer to chapter 3, "3. Adjustment of Timing Between Needle and Rotary Hook."

### 3-11. Program version indication on the operation panel and head display

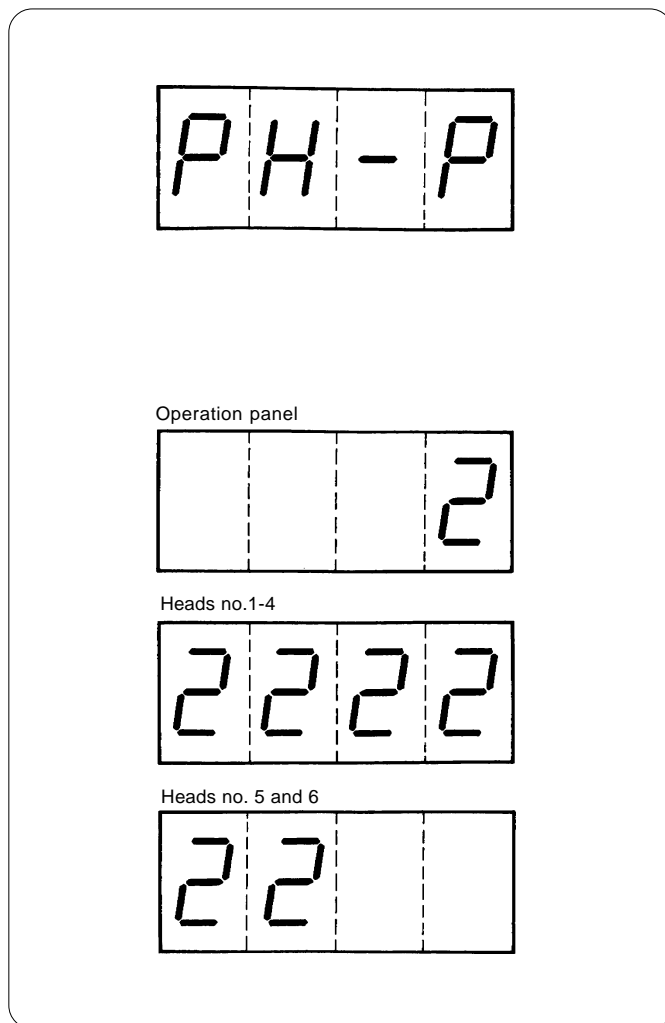

1. With "PH-P" indicated on the 7 segment LED, press the start switch.

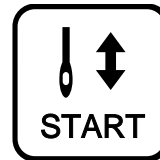

2. The versions of the operation panel, heads 1-4, and heads 5-6 will appear on the 7 segment LED in order.

3. After versions have been indicated, "PH-P" will reappear on the 7 segment LED.

### 3-12. Power voltage and frequency indication

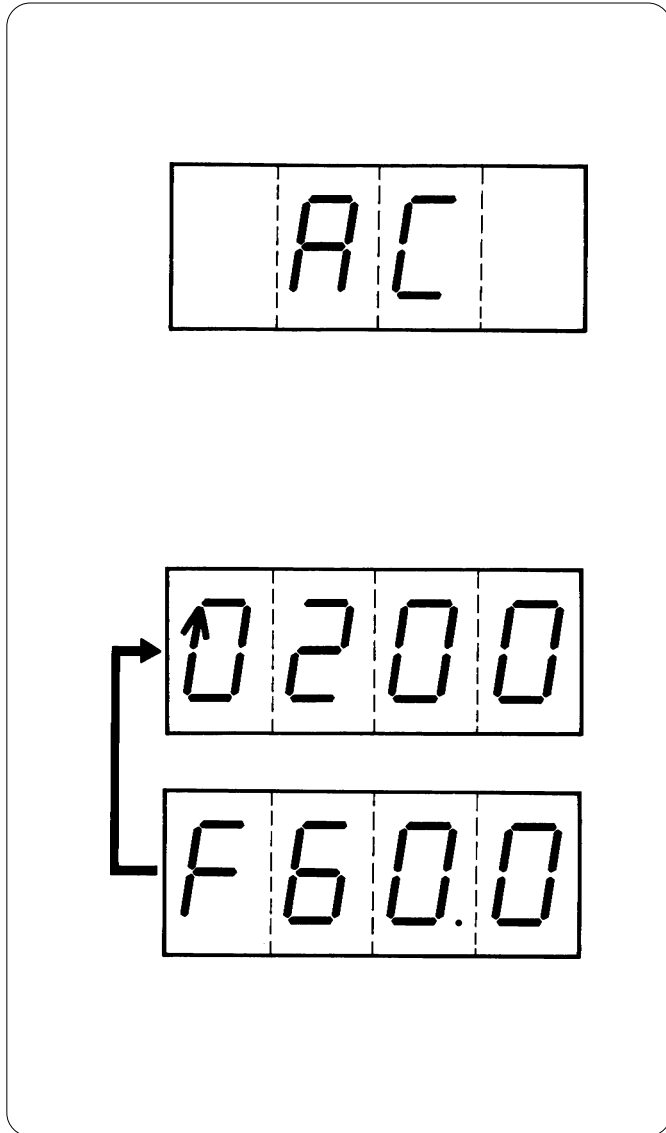

1. With "AC" indicated on the 7 segment LED, press the start switch.

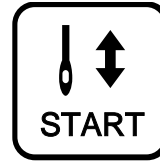

2. The voltage measured on the machine will appear on the 7 segment LED.

3. Press the check switch to indicate the frequency for a time.



4. Press the stop switch to finish the indication. "AC" will reappear on the 7 segment LED.



### 3-13. Port check

- "P--" will appear on the 7 segment LED.
- Press the jog switch ( $\Delta$ ), ( $\triangleright$ ), or ( $\nabla$ ) to check each port.
  - ( $\Delta$ ) Indicates the condition of external port A using a hexadecimal code, "PA\*\*."
  - ( $\triangleright$ ) Indicates the condition of external port B using a hexadecimal code, "PB\*\*."
  - ( $\nabla$ ) Indicates the condition of external port C using a hexadecimal code, "PC\*\*."
- When the stop switch is pressed, the indication will be finished. "P--" will reappear on the 7 segment LED.
- With "P--" indicated on the 7 segment LED, press the stop switch to finish the port check. "Port" will appear on the 7 segment LED.

	BIT7	BIT6	BIT5	BIT4	BIT3	BIT2	BIT1	BIT0
Port A	0	0	0	0	1	Head 6 bed retracting flag 1: Retracted	Head 4 bed retracting flag 1: Retracted	Head 2 bed retracting flag 1: Retracted
Port B	X over-current 1: X over-current 0: Normal	Y over-current 1: Y over-current 0: Normal	X home position sensor 0->1 Goes to home position.	Y home position sensor 0->1 Goes to home position.	-X area sensor 1: Area over 0: Inside Area	+X area sensor 1: Area over	1	1
Port C	Cooling fan motor stop plug 1: Stop 0: Rotate	Lower shaft CPU error flag 0: Lower shaft error 1: No error	Main shaft CPU error flag 0: Driving shaft error 1: No error	0	0	0	0	0

### Meaning of code on 7 segment LED

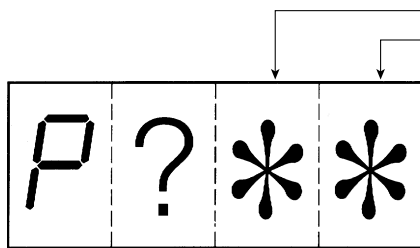

"A," "b," or "c" will appear here.

BIT	7	6	5	4	BIT	3	2	1	0
0	0	0	0	0	0	0	0	0	0
1	0	0	0	1	1	0	0	0	1
2	0	0	1	0	2	0	0	1	0
3	0	0	1	1	3	0	0	1	1
4	0	1	0	0	4	0	1	0	0
5	0	1	0	1	5	0	1	0	1
6	0	1	1	0	6	0	1	1	0
7	0	1	1	1	7	0	1	1	1
8	1	0	0	0	8	1	0	0	0
9	1	0	0	1	9	1	0	0	1
A	1	0	1	0	A	1	0	1	0
b	1	0	1	1	b	1	0	1	1
c	1	1	0	0	c	1	1	0	0
d	1	1	0	1	d	1	1	0	1
E	1	1	1	0	E	1	1	1	0
F	1	1	1	1	F	1	1	1	1

### 3-14. 7 segment LED indication test

1. With "7LEd" indicated on the 7 segment LED, press the start switch.
2. The 7 segment LED indication test will start. Each segment that consists of a character to be displayed on the 7 segment LED will appear in order repeatedly.
3. After 7 segment LED indication test has been completed, "7LEd" will reappear on the 7 segment LED.
4. Press the stop switch to exit from the setting mode.
5. Press the stop switch again to exit from the test mode.

### 3-15. Machine head communication test

1. With "HEAD" indicated on the 7 segment LED, press the start switch.
2. The machine head communication test will start, and each process of the test will be indicated by the position of "-" moving on the 7 segment LED.
3. If an error occurs halfway, its error code will appear; if the test has finished normally, "E-00" will appear.
4. After the test has been completed, press the stop switch.
5. Press the stop switch again to exit from the test mode.

### 3-16. Error sound switching

1. "on" (with error sound) or "OFF" (without error sound) appears on the 7 segment LED.  
Note:  
This indication will be initialized when the power is turned on.
2. Press the check switch to switch on / OFF of the error sound.
3. Press the stop switch to finish the setting of error sound. "bEEP" will appear on the 7 segment LED.

### 3-17. Automatic start at the end of mending

When embroidering was suspended due to thread breakage and then restarted after returning the needle to a position just before where the thread was broken using the step back switch, with the previous version the machine always stopped 5 stitches before the position where the thread was broken.

This function enables the machine to stop at that position for just for 0.5 seconds and automatically restart embroidering, operators not needing to do anything on the machine at that time.

1. While the machine is in standby mode, press the stop switch and the jog switch (up) to enter the test mode. (This function is not available except while the machine is in standby mode.)
2. Press the jog switch (▷) or (◁) to select "A\_go" from the test menu.
3. Press the start switch to indicate OFF or on on the 7 segment LED.
4. Press the check switch to change the current setting.  
OFF: Deactivates the automatic start at the end of mending.  
on: Activates the automatic start at the end of mending.
5. After the setting has been done, press the stop switch to exit from the setting mode.
6. Press the stop switch again to exit from the test mode.  
Note:
  - The setting of this function is kept memorized in a program even when the power of the machine is turned off. It is unnecessary to set it again every time the power is turned on.
  - If this function is not installed in the machine controller, adjust this setting on the PC controller. (Refer to the instruction manual.)

## [Test mode and each function on the PC]

### Note:

Most functions are performed on the PC, however the emergency stop switch can not be controlled from the PC.  
Turn off the power of the machine in the case of unavoidable circumstances.

## 1. PC test mode

### Operation on the PC

1. Make the window for the machine to be tested active. Click on [Test] in the [Operation] menu.
2. The dialogue box will open. Input 960 (Password Common to BES-960 and 1260), and click on [OK].

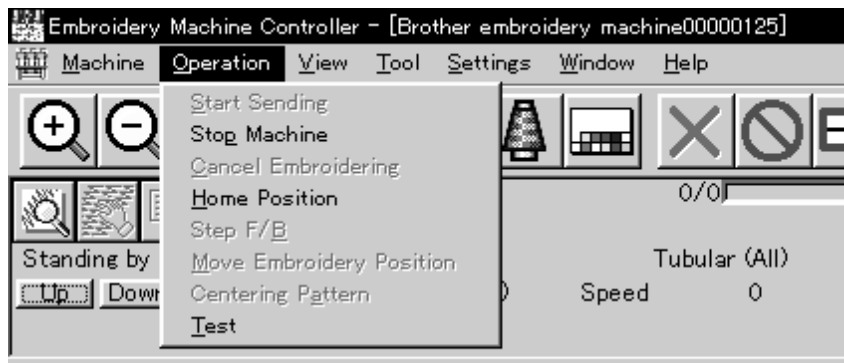

3. Test mode menu list 1 will open. Test modes are arranged in hierarchical order; see "Test mode menu list" for details. A menu screen has the menu title and available commands in the current level. Click on a command number, then [Send] to execute the command. You can also select a command using a number key and Enter key on the keyboard. If the command you select is a command to enter the next menu, the next menu appears; if you select a command to display results, the results appears.



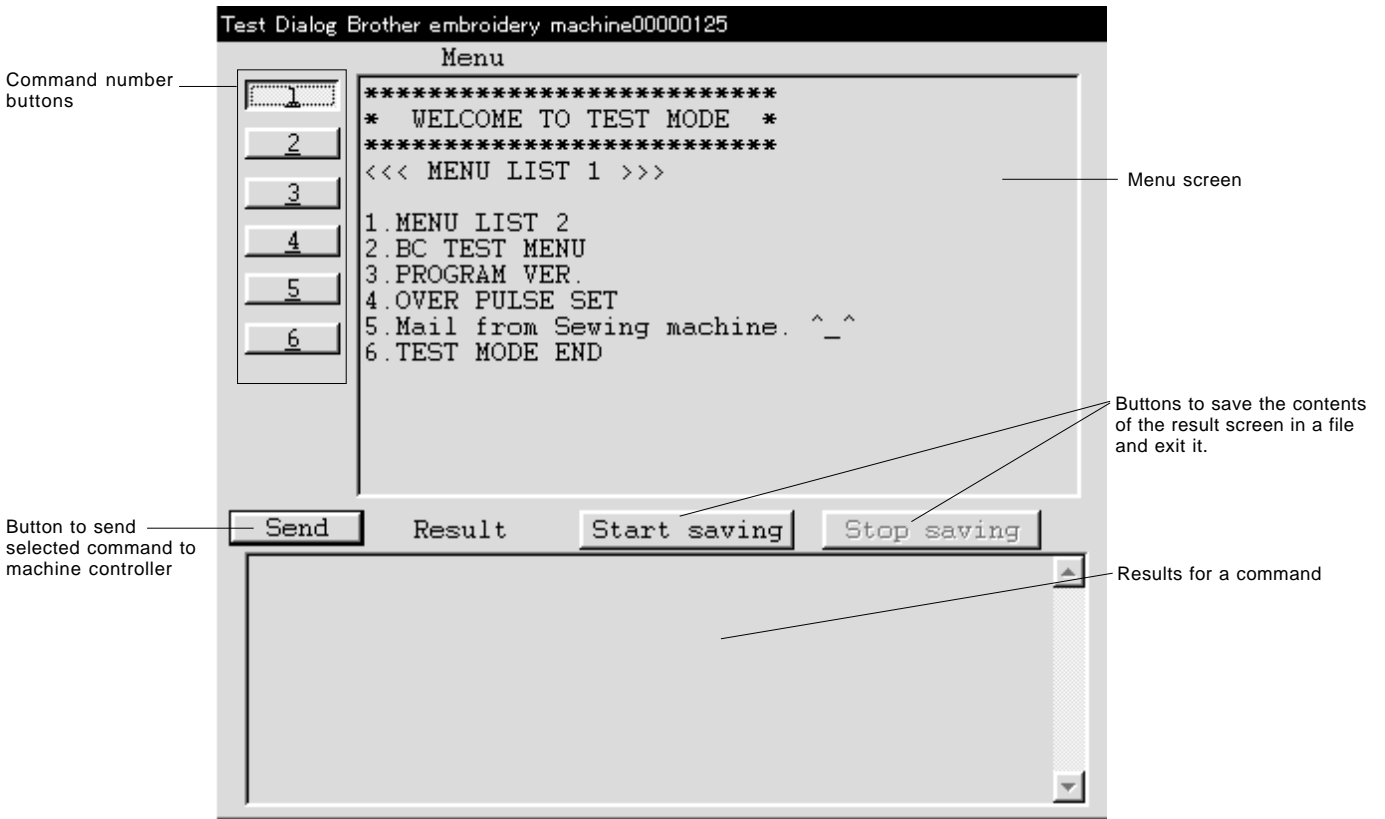

When finishing the test mode, return to the original stage from the current stage, and select command "6.TEST MODE END" to close the test mode dialog.

When executing save start, the contents of all result screens until save stop is executed will be saved in a file that has been specified.

## 2. Confirming the program version

<Version for machine controller and master I/F CPU program>

1. Click on [?] in the machine controller's toolbar.

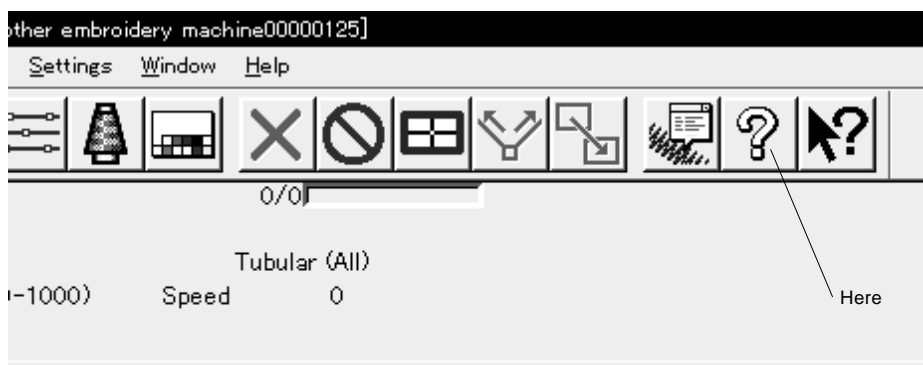

- The dialog box about this application will appear indicating machine controller's and master I/F's versions. After confirming the version number, click on [OK] to close the dialog.

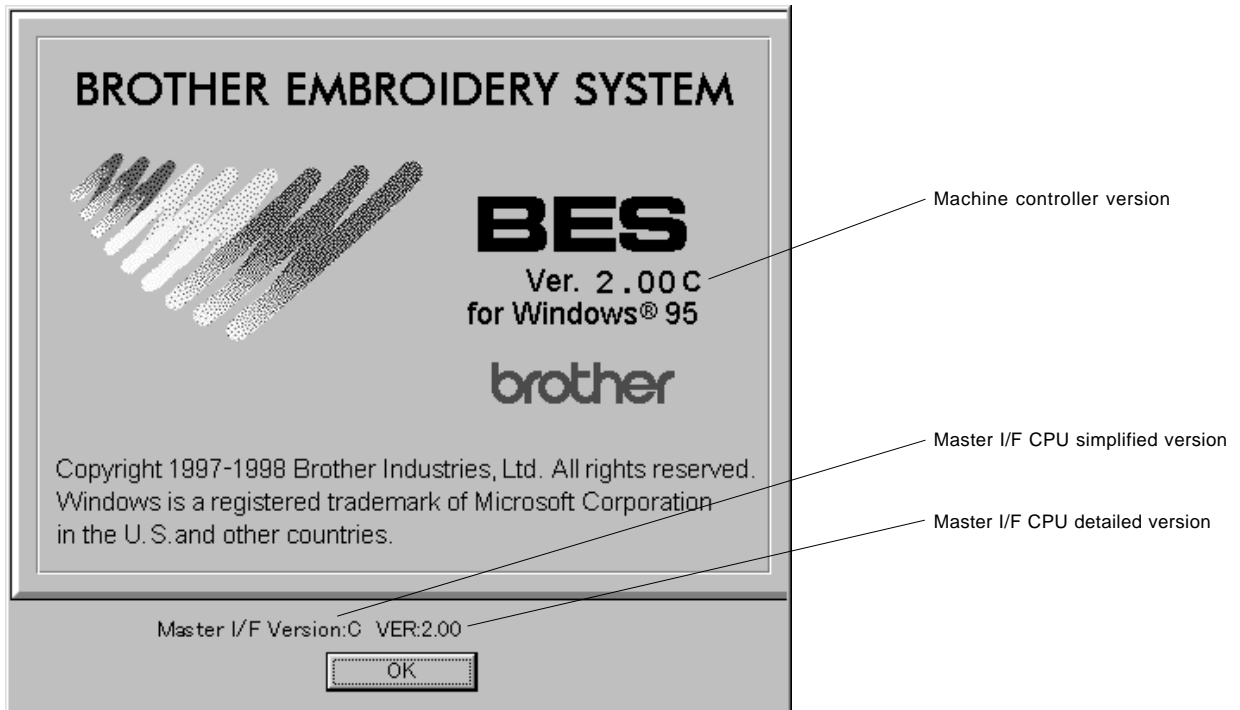

### <CPU simplified version>

- Activate the window of the machine you want to confirm its CPU program version, and select [Machine Information] from Machine menu.

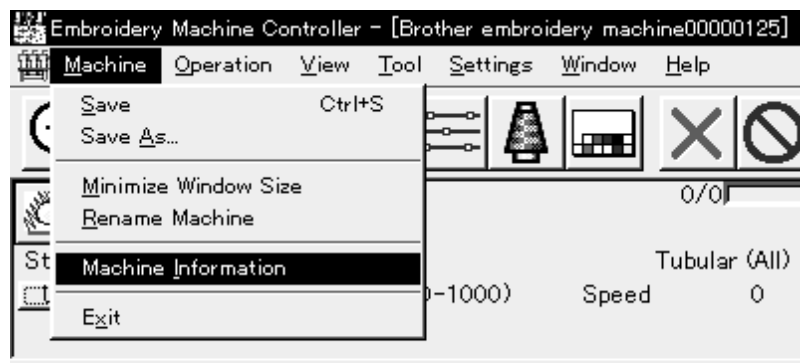

2. The machine feature dialogue will appear indicating the main CPU ROM version, the lower shaft CPU ROM version, the upper shaft CPU ROM version, the I/F CPU ROM version and so on.  
After confirming the versions, click on [OK] to close the dialog box.

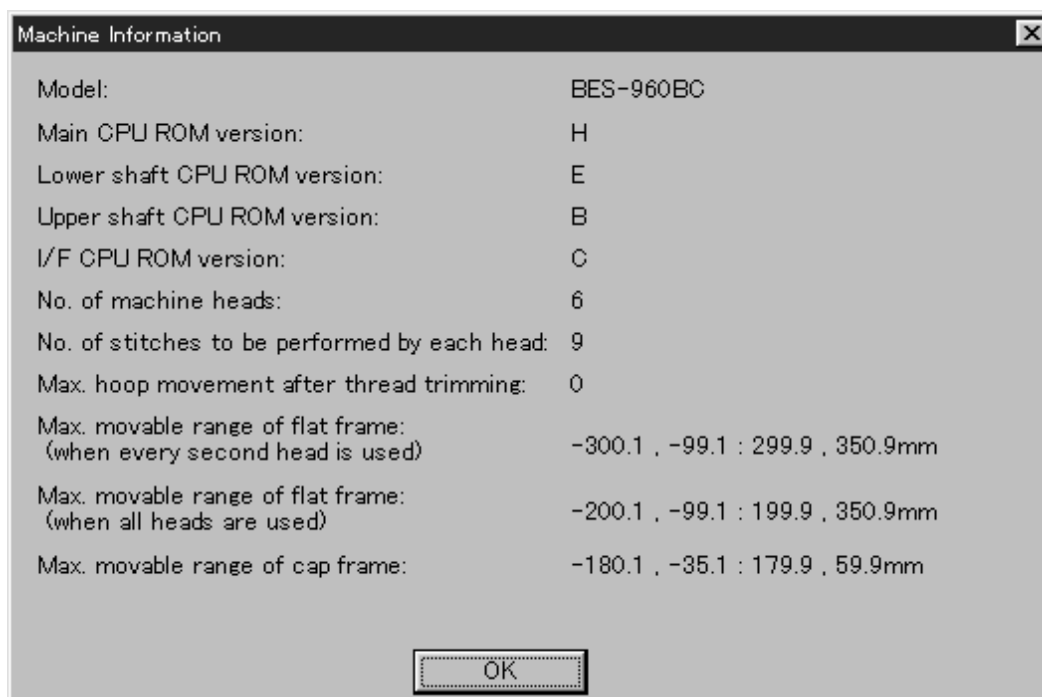

## &lt;CPU detail version&gt;

1. Referring to "1. PC test mode," enter the PC test mode menu list 1.
2. Perform command "3. PROGRAM VER."

Note: Refer to "1. PC test mode" for operation procedure.

3. Select a number from 2 to 6 to indicate the version number of a desired CPU program on the result screen.

- |                          |                                |
|--------------------------|--------------------------------|
| 2: Main CPU program      | 5: Panel and head CPU program  |
| 3: Bobbin motor program  | 6: XY wave form table          |
| 4: Slave I/F CPU program | 7: All CPU programs in machine |

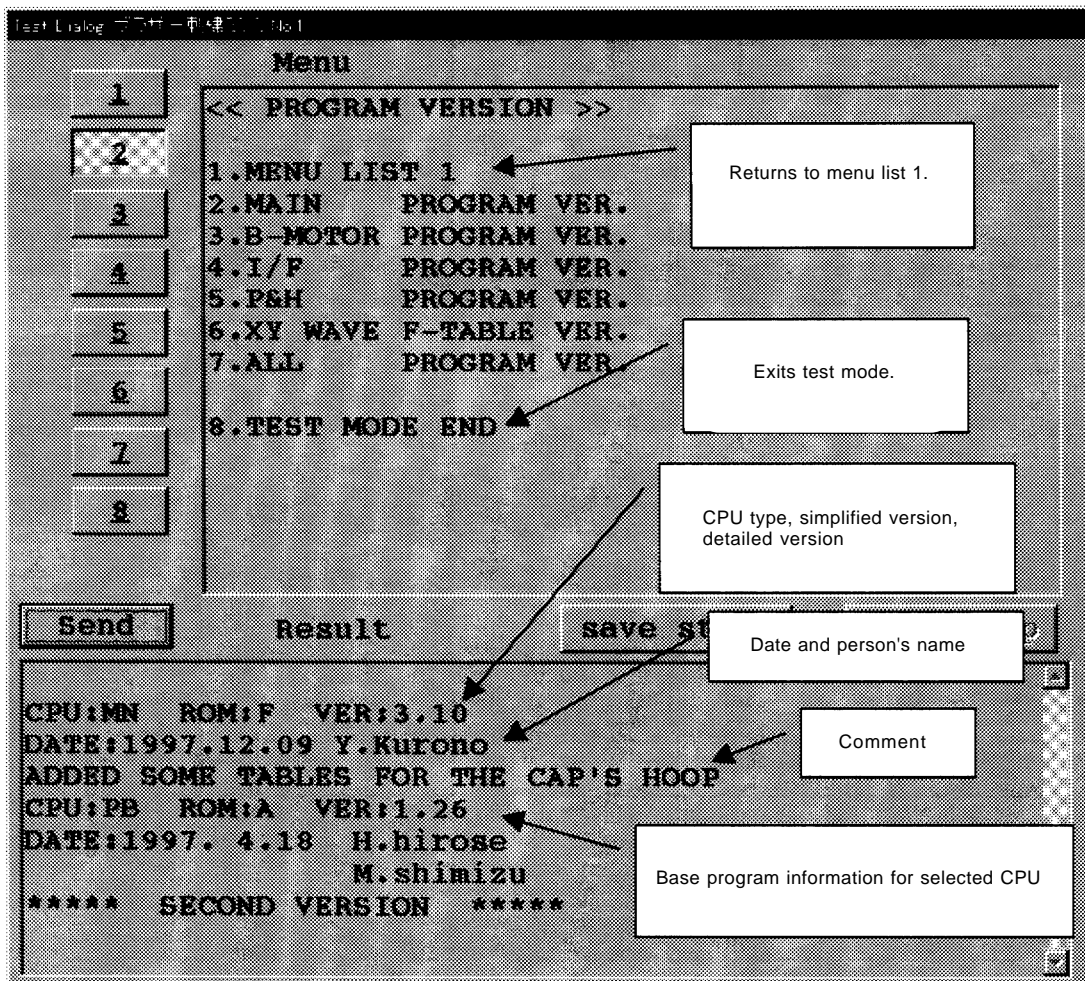

After confirming the information, exit the test mode to close the dialog box.

### 3. Confirming and deleting the BC error

Of the errors which occur in the machine, errors E-B1, B7, B8, D0, D1, D2, and D3 are memorized in the machine about 400 times as error data. The error data can be confirmed and deleted.

1. Referring to "1. PC test mode," enter the PC test mode menu list 1.
  2. Perform command "2. BC TEST MENU."
- Note:  
Refer to "1. PC test mode" for the operation procedure.
3. Perform command "5. Error data information" from the BC test menu.
  4. Confirm error information by clicking on the number indicating the information you want.

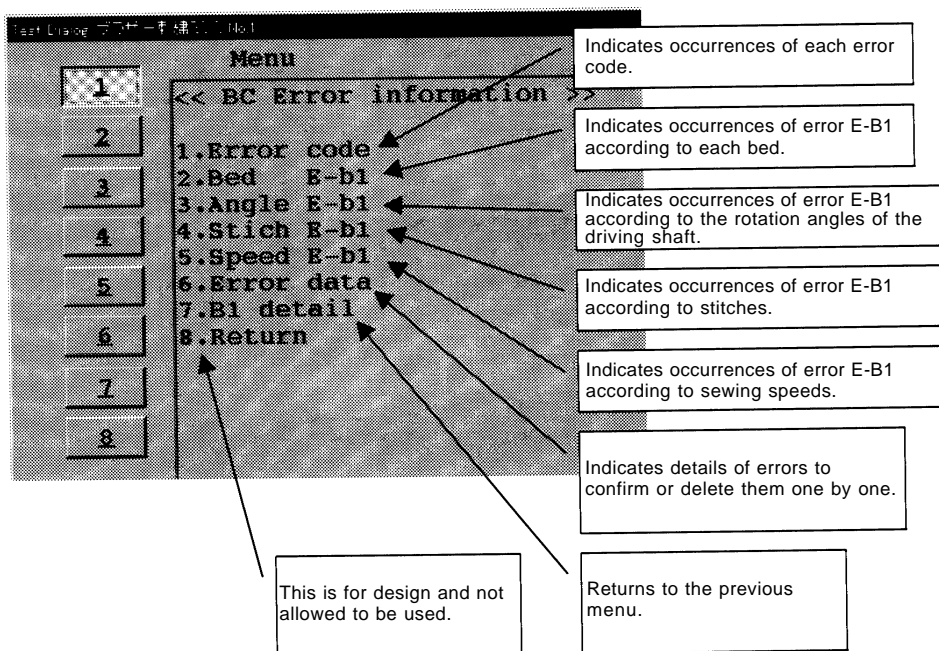

The following is an example of a result screen about error B1 which occurred at each bed, the screen showing how often error B1 occurred.

Error Bed information ...b1	
Bed	count
1	23
2	19
3	1
4	1
5	2
6	16

5. Perform command "6. Error data" to confirm or delete error details one by one.
  6. Select a command number from 1 to 4 in the error data menu to show error data. Data will appear in the order which it occurs. The last data displayed at the bottom page is the most recent. Error data is indicated with one error in one line and seven lines in one screen, as shown in the result screen below.
- There are seven error codes: B1, B7, B8, D0, D1, D2, and D3.
  - "x" indicates the bed in which the error occurred.
  - The angle is that of the driving shaft when the error occurred.
  - The number of stitches from thread trimming is how many stitches were sewn from the last time thread trimming was performed until the place the error occurred.
  - The number of stitches from restarting is how many stitches were sewn after the machine operation was suspended due to some reason such as a color change, thread breakage, or activation of the emergency stop switch.
  - The speed is that of the driving shaft when the error occurred.

Error codes except for E-B1 are not related to embroidering.

**Menu**

<< Error data >>

1. Top page
2. Bottom page
3. Next page
4. Back page
5. Data clear
6. Return

**Result**

B1	oxxxxo	233	49	49	507
B1	oxxxxo	241	105	54	546
B1	oxxxxo	250	352	245	507
B1	oxxxxo	241	618	264	579
B1	oxxxxo	259	1343	723	852
B1	oxxoox	274	4	4	110
B1	oxoooo	317	965	354	965

< 62/ 62 >

7. Perform command "5. Data clear" to delete error data.
8. Execute password. When you input a password, select a number for the password, and then [Send] button. When the password has been input, perform command "8. OK". If the password is correct, the result screen will show the message, "Data clear. OK?". Click on [OK] if you want to delete all error codes. If you cancel the deletion, select command "6. Return" to exit from the error data menu and return to the previous menu.

The following is a series of operation to input password for data clear:

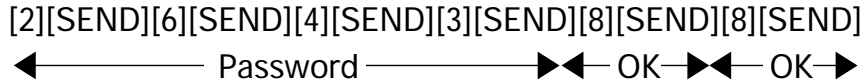

9. When error data is cleared normally, "Data clear complete" will appear on the result screen and the indication will return to the previous menu.

## 4. BC sensor test

This test checks the signal of the BC sensor by rotating the lower shaft on each machine head. Please keep in mind that the machine cannot be stopped even using the emergency stop switch while the lower shaft is rotated in this test mode. Turn off the power of the machine in the case of an emergency. The rotation speed indicated in the test mode is not the actual speed of the lower shaft but the speed in terms of the driving shaft. The actual lower shaft is rotated at a speed of twice as fast as the indicated one.

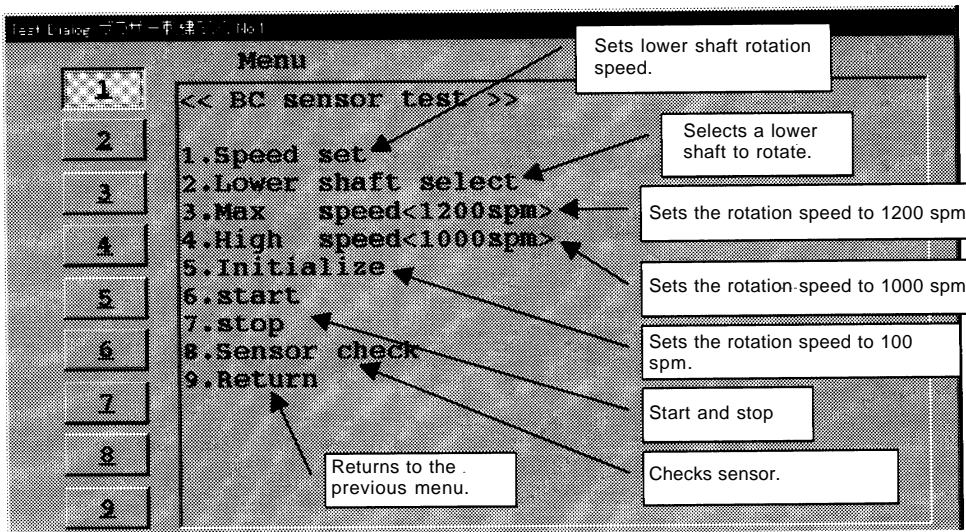

1. Referring to "1. PC test mode," enter the PC test mode menu list 1.
2. Perform command "2. BC TEST MENU" from the PC test mode menu list 1.

Note:

Refer to "1. PC test mode" for operation procedure.

3. Perform command "4. BC Sensor test" from the BC test menu to enter the BC sensor test menu.
4. Perform command "6. Start" from the BC sensor test menu. A lower shaft can be rotated. However, no lower shaft will turn because the lower shaft to rotate is not selected yet.
5. Perform command "2. Lower shaft select" from the BC sensor test menu to select a lower shaft to rotate from the BC sensor sub menu.

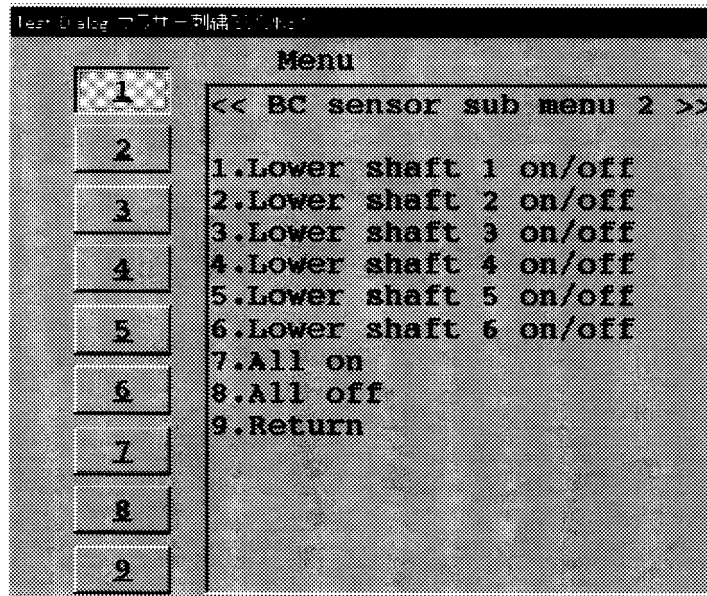

6. In the BC sensor sub menu 2, use commands 1 - 6 to determine lower shafts to rotate or not, one by one. Use commands 7 and 8 to set all lower shafts to on or off at once. However, a lower shaft that has been stopped can not be rotated suddenly with a speed of 200 spm or more. In this case, use command "5. Initialize" of the BC sensor test menu or "1. Speed set" of the BC sensor test to decrease the speed to 100 spm. The BC sensor test is performed for one lower shaft. If several lower shafts are rotating, only the lower shaft with the smallest bed number is checked. After selecting a lower shaft to test its sensor, select command "9. Return" to return to the previous menu.
7. Perform command "3. MAX speed <1200 spm>" from the BC sensor test menu. The lower shaft will rotate at a speed of 2400 rpm.



8. Perform command "8. Sensor check" from the BC sensor test menu. A BC sensor of the rotating lower shaft which is in the bed with the smallest number will be checked, and the results will appear.

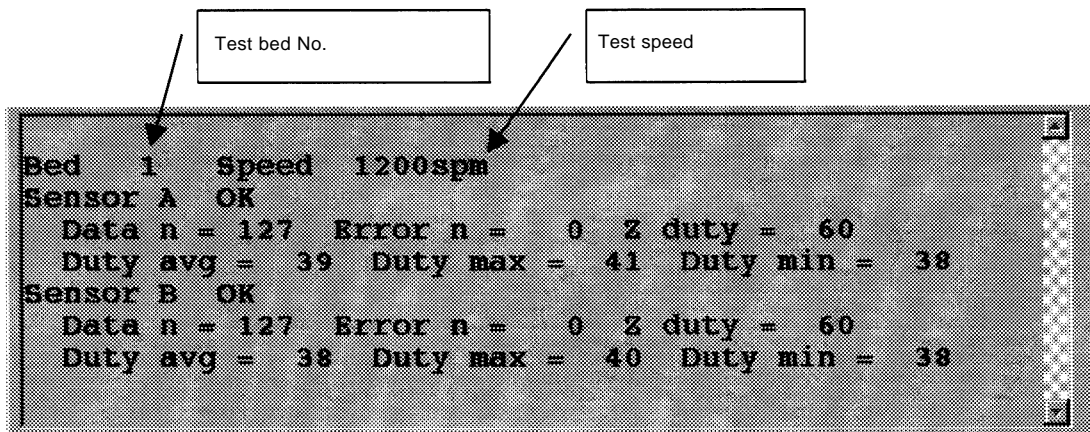

There are two sensors in the lower shaft module: sensor A and sensor B. The results of their signal checks will appear respectively. When the results of both sensors A and B are OK, the BC sensor PCB in the bed is normal. If the results are not OK, adjust sensors referring to chapter 2, "14. Replacing and adjusting the lower shaft module."

9. When sensor tests of all lower shafts are completed, be sure to select command "7. Stop" to stop all lower shafts, then "9. Return" to return to the previous menu, and finish the test mode. Please keep in mind that the lower shaft is not recognized it is stopped in the test mode when command "2. Lower shaft select" has been selected to stop the lower shaft.

## 5. Lower shaft module test (BC auto test)

The lower shaft module auto test (BC auto test) is included in the BES960BC upgrade file, BES-960-106.bup or later.

ROM:D Ver:1.03Å Date:1997.10.8

Following are functions of the BC auto test:

- Lower shaft running-in function  
This function enables all lower shaft modules repeatedly to be run-in using a combination of low and high speeds.
- Synchronization limitation among all lower shaft modules (auto test)  
Measures synchronization limitation among all lower shaft modules with four different speeds.

Note:

When any lower shaft is rotating in this test mode, the machine can not be stopped even with a push of the emergency stop switch. Turn off the power of the machine in an emergency.

### Procedure

1. Referring to "1. PC test mode," enter the PC test mode menu list 1.
2. Perform command "2. BC TEST MENU" from the PC test mode menu list 1.  
Note:  
Refer to "1. PC test mode" for the operation procedure.
3. Perform command "8. BC Auto Test" from the BC test menu to enter the BC auto test menu.

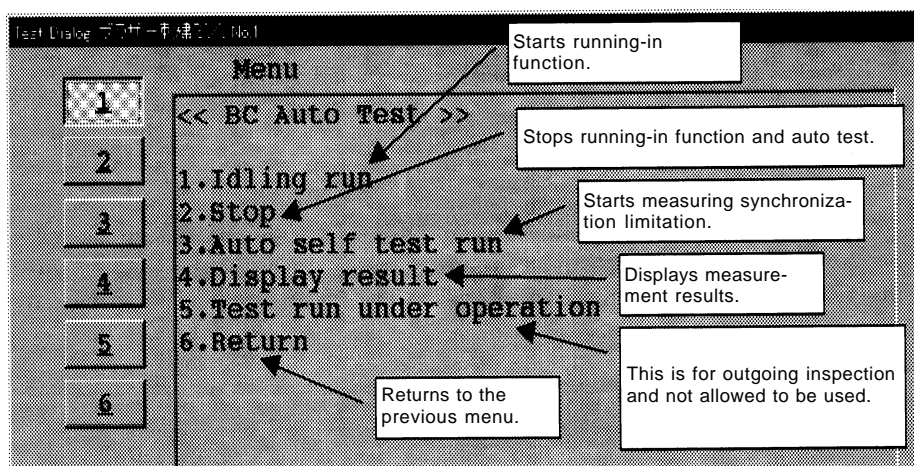

4. To start the lower shaft running-in function, perform command "1. Idling run" from the BC auto test menu. All lower shafts will start running-in operation with a certain speed pattern, and speed parameters will appear on the screen. It is recommended that four hours are allowed for this function. To stop this function, perform command "2. Stop."

5. To measure the synchronization limitation of the lower shaft module, perform command "3. Auto self test run." "Auto Motor test NOW!" will appear on the screen, and the synchronization limitation of each lower shaft module will be automatically measured in each of four speed ranges, in order starting with module No.1. After all modules have been measured, all rotary hooks will search for their home positions and then stop there. When all modules or a rotary hook to be measured have stopped, perform command "4. Display result" to see the test results.

The following is an example of the test results:

No.	TP1	TP2	TP3	TP4	JUDGE	
1	340	450	470	470	OK	← When auto test's result is OK
2	360	490	480	490	OK	
3	330	460	450	440	OK	
4	340	470	440	850	NG	← When the result is not accepted because it is beyond the synchronization limitation.
5	Error					← Module does not turn normally (because it is not connected).
6	340	0	0	0	--	← Measuring

To cancel the auto measurement halfway, perform command "2. Stop."

Even when the auto measurement is suspended halfway, you can confirm the results for up to the module that was being measured.

6. To exit the test mode while the running-in function or synchronization limitation function is being performed, perform command "6. Return" to return to the previous test menu, and then "9. TEST MODE END." In this manner, it is possible to test a machine while performing sewing on another machine, and testing another different machine at the same time.

To stop the running-in function or see the results of auto test, perform the above procedure from step 1 until the BC auto test menu appears, and perform a desired function from the BC auto test menu.

On the machine where the running-in function or auto test is being performed, sewing, manual thread trimming, or other tests can not be performed.

If you want to perform sewing, manual thread trimming, or other tests on the machine, stop the running-in function or auto test.

7. After the lower shaft module test has been completed, if any lower shaft is rotating, perform command "2. Stop" to stop it, and then return to the previous menu.

## 6. Power supply voltage adjustment

Note:

BES-960 checks the power supply voltage to control it optimally even if it varies or to cope with abnormal voltage supplies.

This function is adjusted before shipment from the factory. However, if the main PCB, the power supply PCB, or the control box is replaced, the adjustment becomes ineffective.

Be sure to adjust the power supply voltage as follows when replacing the main PCB, the power supply PCB, or the control box:

### Procedure

1. Referring to "1. PC test mode," enter the PC test mode menu list 1.

2. Perform command "2. BC TEST MENU."

Note:

Refer to "1. PC test mode" for the operation procedure.

3. Perform command "2. Voltage adjust" from the BC test menu. The Voltage adjust menu will appear.

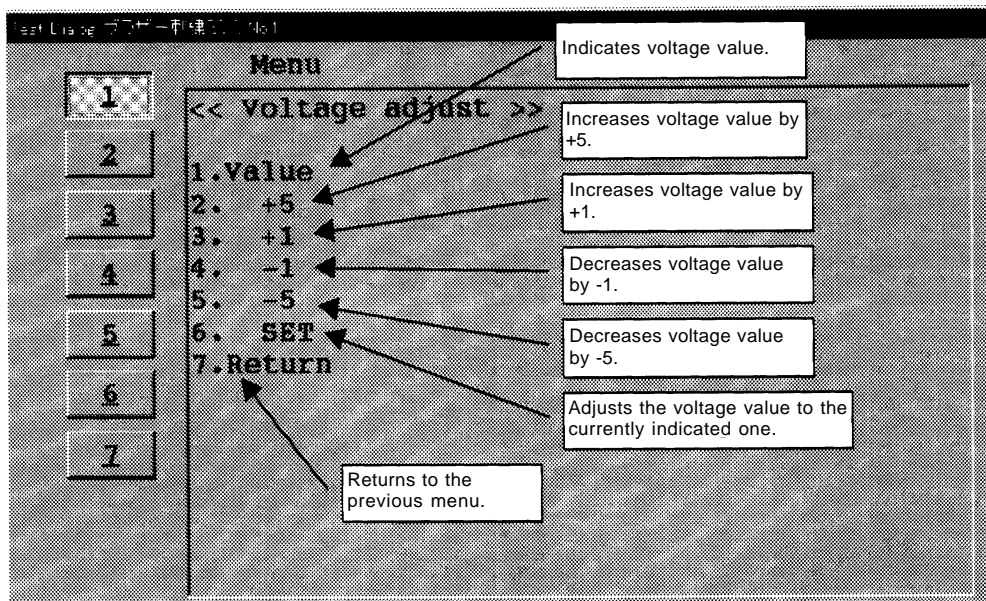

4. Perform command "1. Value" from the Voltage adjust menu. The current voltage value will appear.

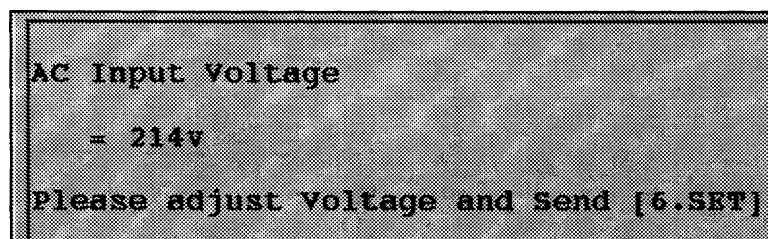

5. Carefully measure power supply voltage of the machine using a tester. Major measuring points are breaker terminals in the machine, between pins 1 and 2 of connector 18 at the rear of the control box, and power source outlet.
6. Using commands 2-5, change the value indicated on the screen to the measured value, and perform command "6. SET" to adjust the value indicated on the screen to the measured value.  
For example, assume the measured value is 220 V and the value indicated on the screen is 214 V. To display the measured value, 220 V, on the screen, perform command "2. +5" once ( $214 + 5 = 219$ ), and then command "3. +1" once ( $219 + 1 = 220$ ).
7. Perform command "1. Value" again to reconfirm the voltage. The power supply voltage slightly fluctuates while it is being adjusted. If it is within  $\pm 2$  V, it is OK. After the voltage has been adjusted, perform command "7. Return" to return to the previous menu, and exit from the test mode.

# Chapter 5 Upgrading version of machine program

This chapter explains how to upgrade the version of BES960BC programs using the upgrade file which is supplied on the machine controller CD-ROM, a floppy disk, or sent by e-mail.

1. Copy the upgrade file for BES960BC onto the hard disk of the PC connected to the machine.

File to copy : Copy the file "BES960-xxx.bup". "xxx" of the file name is a 3-digit number to identify the version.

Where to copy : In the Verup folder in which the machine controller has been installed.  
If you have not specified the drive or folder when installing, the file will be copied to C:/Program Files/Bes-960/Verup. (Refer to that below.)

This folder is automatically created when the machine controller is started. If this folder already contains an old upgrade file, create another folder and move it to avoid misoperation because of handling the inappropriate upgrade file.

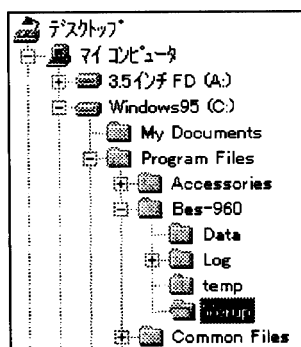

If you copy from the CD-ROM : while pressing the Shift key, put the disk of BROTHER EMBROIDERY SYSTEM in the CD-ROM drive, and copy the upgrade file from the Verup folder in the CD-ROM drive. The Shift key is used to prevent any setup programs from booting up; it should be kept pressed for a while. If any setup program boots up, cancel the setup before copying.

2. Start the machine controller, and turn on the machine that will be upgraded. If the machine is about to restart sewing after suspension, cancel sewing from the machine panel, and then click x button on the machine's toolbar. (A pattern in the middle of sewing will be canceled.) When the READY lamp on the machine panel is lit, click x button on the machine's toolbar to cancel the sewing data.

3. In the window for a machine to be upgraded, move the pointer to the Tool menu to select the Upgrade Interface Board. The sub menu will appear with four commands to upgrade CPUs. The number of CPUs to be upgraded once is only one. When upgrading each CPU, repeat steps 3-8 for each. Select "1. Lower shaft." (Refer to the figure below.)

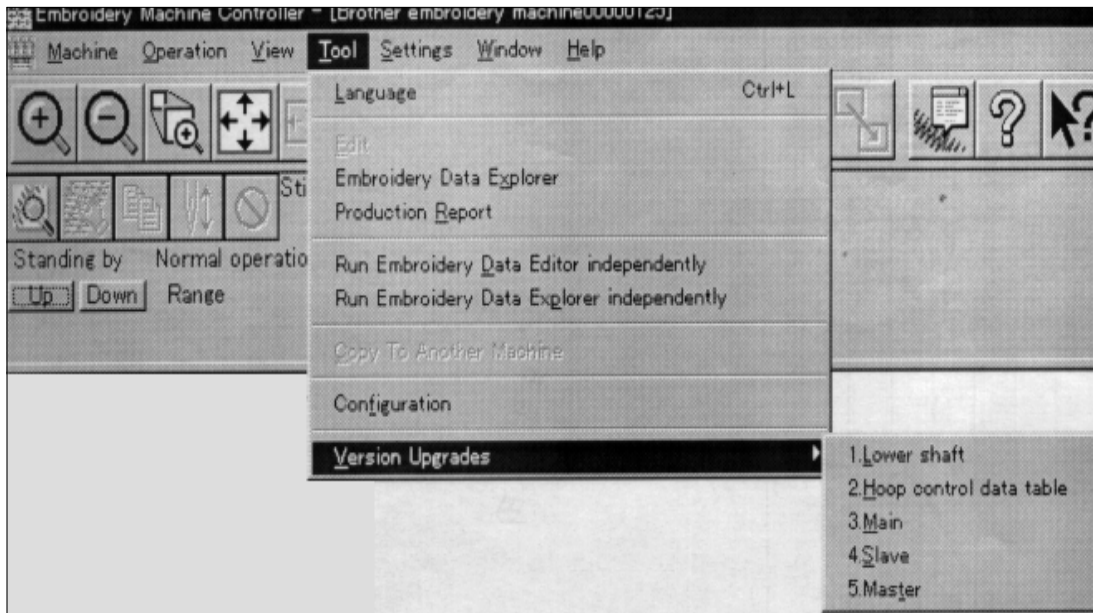

4. The password dialog box will open. Input 960, and click [OK].
5. The system will ask you whether to upgrade the CPU or not. Click [OK] to upgrade it.
6. The dialogue box for selecting an upgrade file will open. Select the latest upgrade file copied in step 1, and click [Open].
7. When the upgrade for the version of the selected CPU starts, the indicator shows the degree of the upgrade progress performed. On the machine panel, "P. Upd" will be blinking with the buzzer sounding. (When upgrading the version of a slave CPU, nothing appears on the machine panel.) Do not operate the machine while upgrading.
8. Once upgrading of the version has been normally completed, the status bar (on the bottom of the PC's screen) shows "Normal operation: Version upgrade has been completed," and the machine panel shows "P.End." For a slave CPU, the machine window shuts and re-opens. When upgrading of the version is not normally completed, perform the upgrade for the CPU again.

9. With "P.End" displayed on the machine panel, repeat the above steps 3 to 8 until the versions of all CPUs on the machine have been upgraded. After upgrading the versions of all CPUs, press the stop switch on the machine panel. The machine will restart with its version upgraded.
10. If the PC is connected to multiple machines, repeat the above steps 2-9 to upgrade the versions of other machines.
11. When all machines connected to the PC have been upgraded completely, go to step 3, and click "5. Master" to upgrade the version of the interface board inserted in the slot of the PC. Then perform the above steps 4 - 7.
12. When the version of the master (the interface board) has been upgraded completely, the status bar shows "version upgrade has been completed," and the machine's window shuts and re-opens. When the upgrade is not normally completed, perform the master version upgrade again. This completes version upgrade of the machine.



# Chapter 6 Maintenance

## ⚠ CAUTION

- ⚠ Turn off the power switch before starting maintenance.  
Failure to do so may start the machine unintentionally through an accidental activation of the START switch, resulting in bodily injuries.
- ⊘ Be sure to wear protective goggles and gloves when handling the lubricating oil or grease, so that no oil or grease gets into your eyes or onto your skin, otherwise inflammation can result.  
Furthermore, do not drink the oil or grease under any circumstances, as they can cause vomiting and diarrhoea.  
Keep the oil out of the reach of children.

- Keep the machine clean at all times to prevent machine trouble.
- Keep the machine clean.  
Remove dirt with a soft, dry cloth. If necessary, clean with the detergent-soaked cloth, then wipe off the detergent with a cloth dampened with (hot) water.
- Caution  
Never use benzene or thinner for cleaning the machine.

## 1. Cleaning Rotary Hook

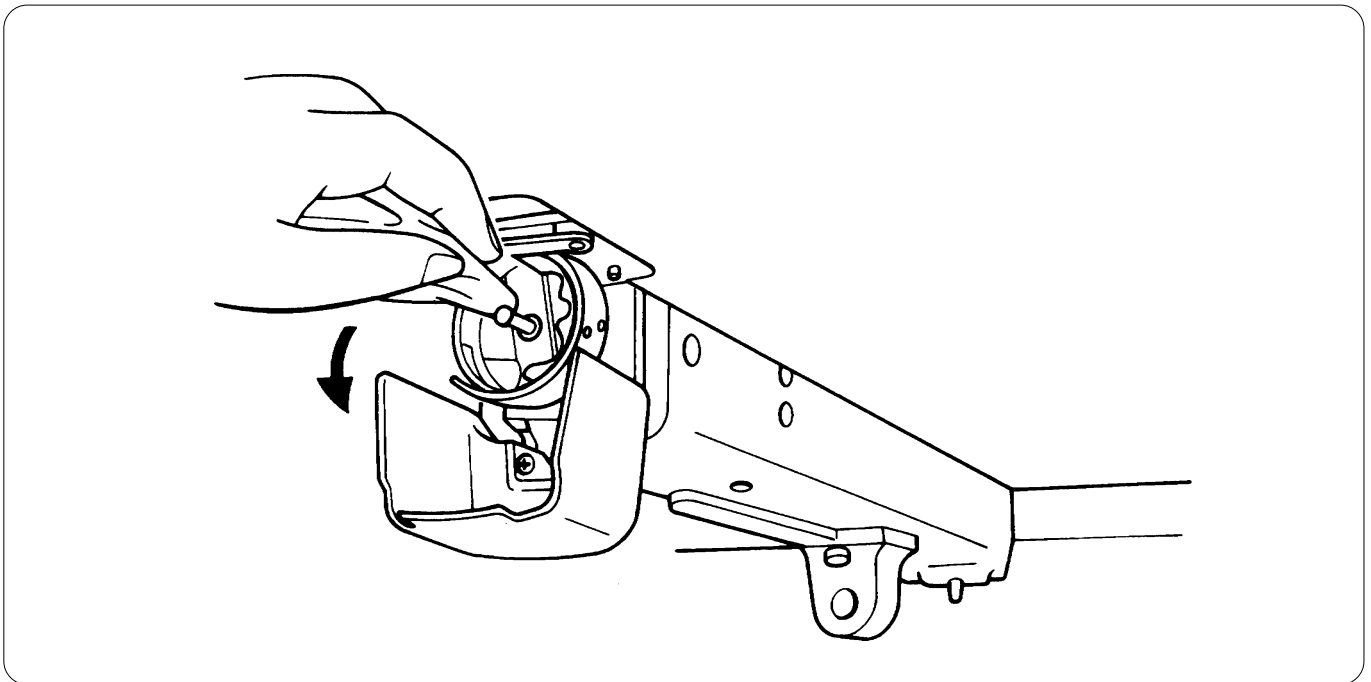

## 2. Oiling

To extend the machine's service life, supply oil to the following places at regular intervals.

Note:

- When oiling, be sure to supply Brother's machine oil (Nisseki Sewing Lube #10 or the equivalent) using the dropper.
- Excessive oiling may cause the material to be stained.

### 2-1. Head

#### BES-960BC

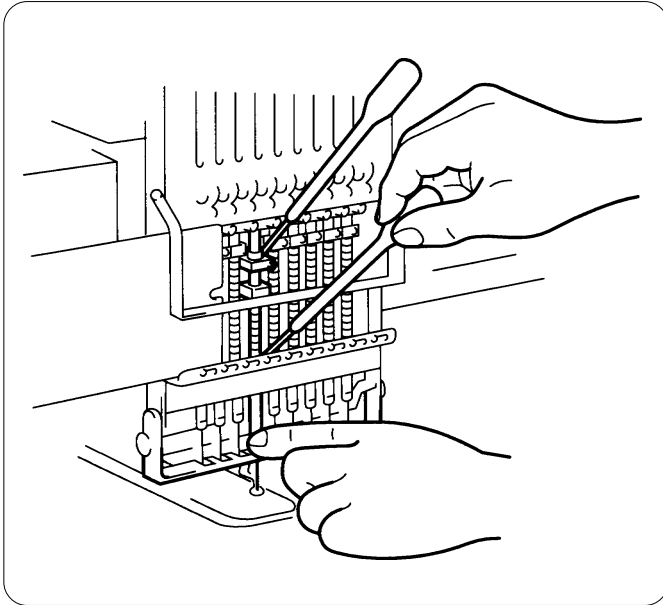

Supply oil to the needle bars (18 positions) once a day as shown on the left.

#### BES-1260BC

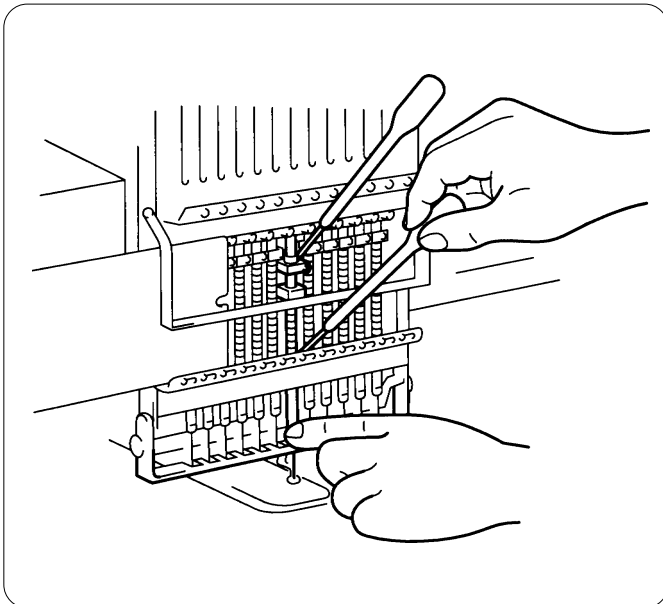

Supply oil to the needle bars (24 positions) once a day as shown on the left.

### BES-960BC

Lubricate the following part indicated by the arrow ("clearance" between the connecting rod and the needle thread take-up bearing) once a week.

Note:

- In lubrication, select needle bar No.9 and remove arm cover L to check the lubrication area. Be sure to wipe off excessive oil spill at the lower part of the arm.

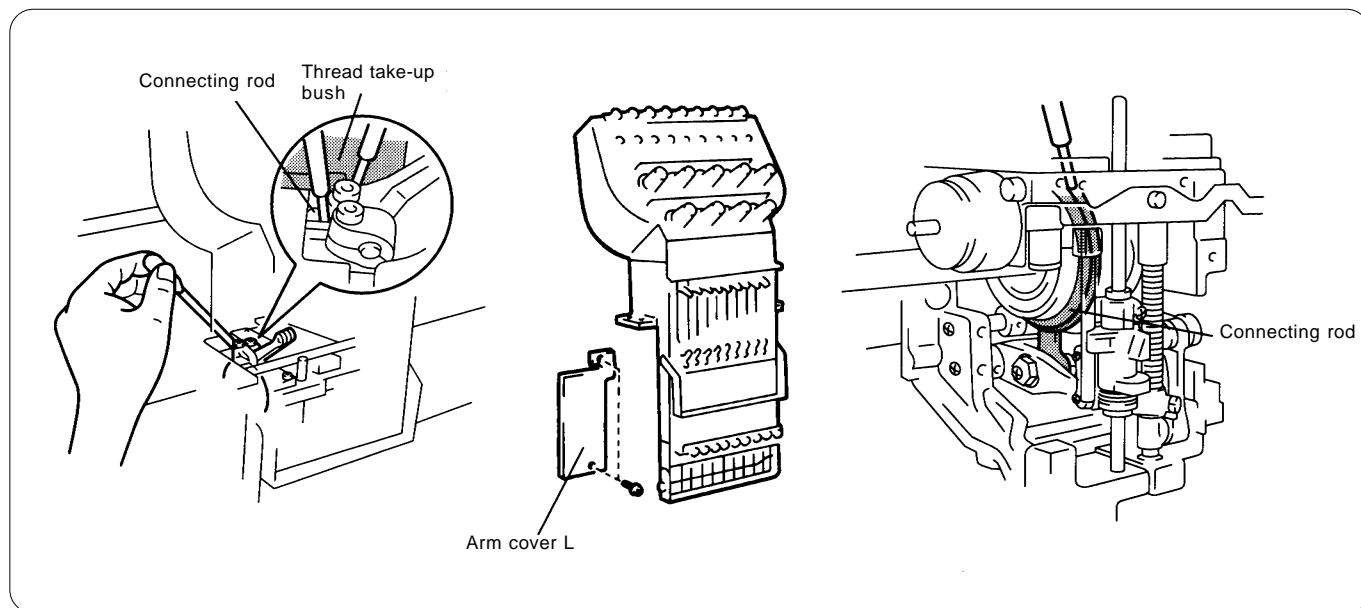

### BES-1260BC

Lubricate the following part indicated by the arrow ("clearance" between the connecting rod and the needle thread take-up bearing) once a week.

Note:

- In lubrication, select needle bar No.12 and remove the head cover to check the lubrication area. Be sure to wipe off excessive oil spill at the lower part of the arm.

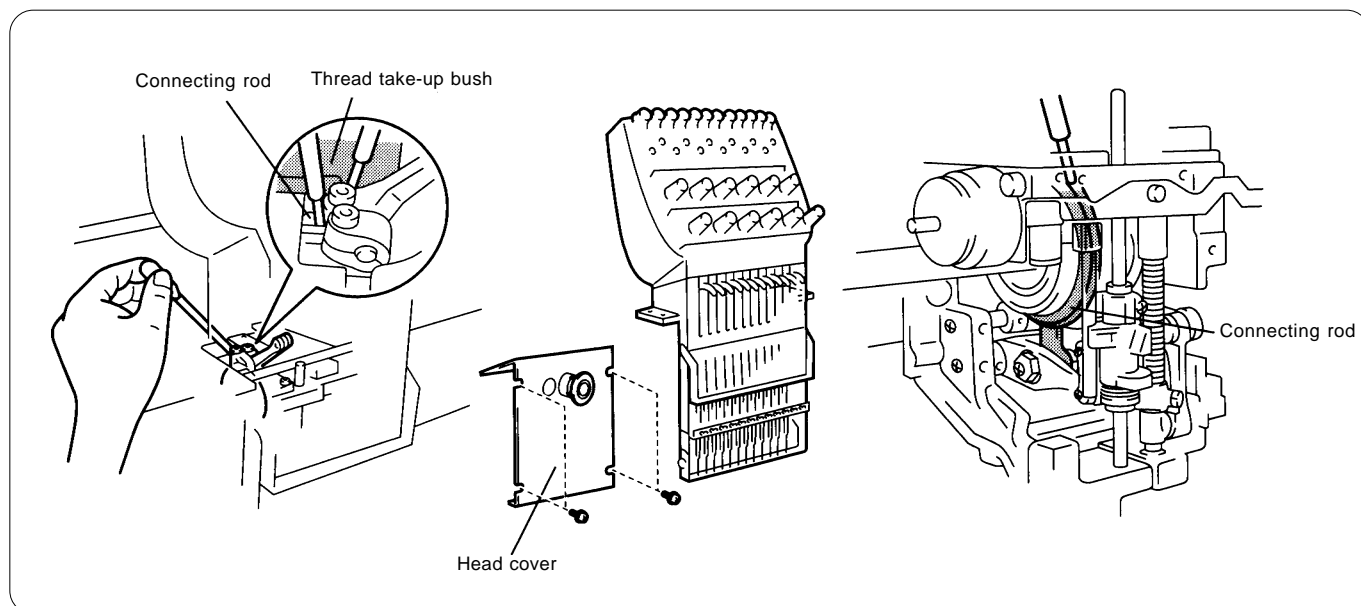

## 3. Greasing

To extend the machine's service life, supply grease to the following places at regular intervals.

Note:

- When greasing, be sure to use the grease tank BR2 (black) provided with the machine.
- For overhauling, contact your distributor or refer it to trained experts.

### 3-1. Head

Grease two places indicated by the arrow once a month.

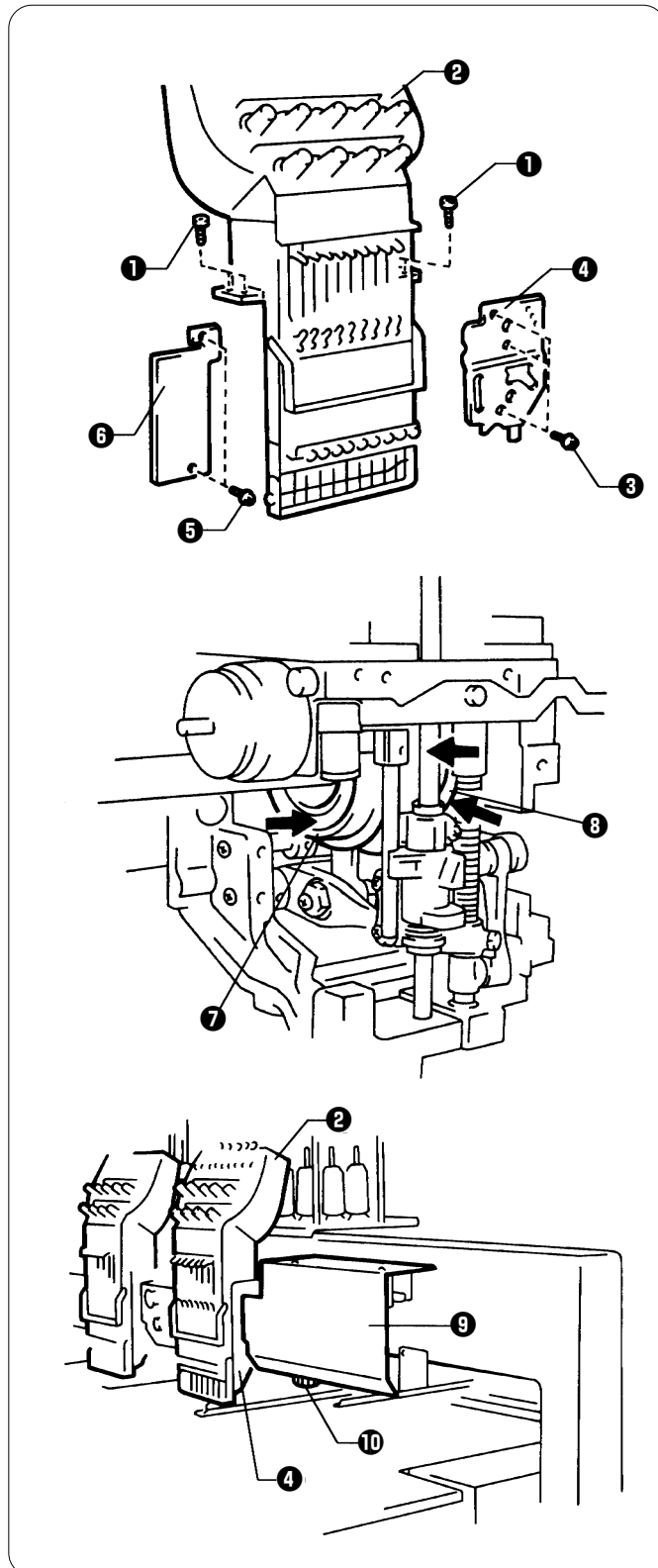

#### BES-960BC

1. Remove two connectors from the rear of the needle bar case.
2. Loosen four bolts ①, and remove the needle case ②.
3. Loosen three screws ③, and remove the presser foot guide plate ④.
4. Loosen two bolts ⑤, and remove the arm cover L ⑥.
5. Grease all the grooves of the thread take-up cam ⑦ and the work clamp cam ⑧.
6. After greasing, assemble in the reverse order.

Note:

- When assembling the needle bar case ②, place it on the machine and turn the change pulley ⑩ behind the cover ⑨ at right. Check that it is engaged, and then tighten the bolts.
- When attaching the presser foot guide plate ④, move the presser foot up and down by the retracting lever to check that it is not distorted.

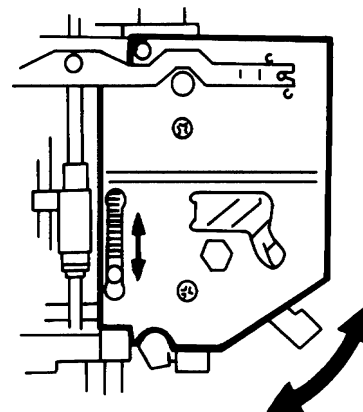

BES-1260BC

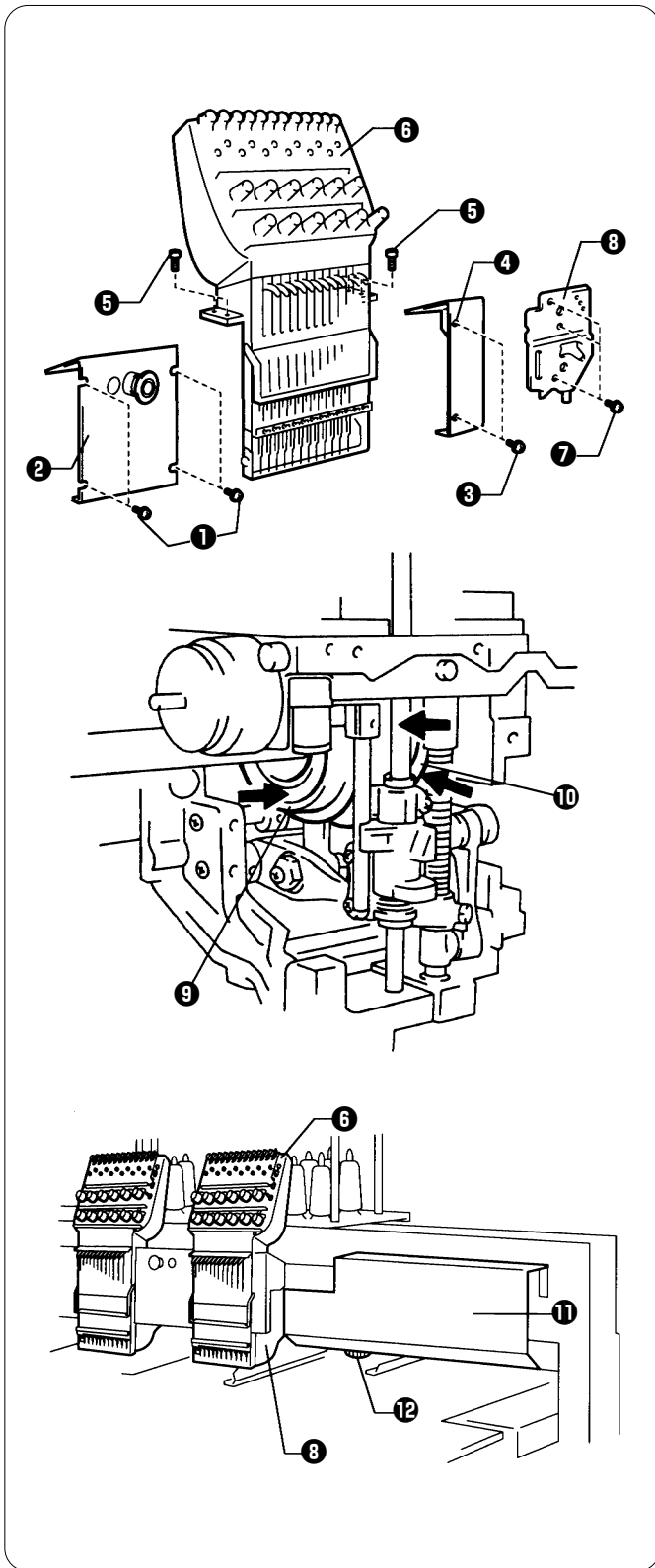

1. Remove two connectors from the rear of the needle bar case.

2. Loosen four screws ①, and remove the head cover ②, and loosen two screws ③ and remove the head cover R ④.

Note:

Because the heads No.1 and No.2 have the head covers R and L respectively, remove both the the covers when greasing.

3. Loosen four bolts ⑤, and remove needle bar case ⑥.

4. Loosen three bolts ⑦, and remove presser foot guide plate ⑧.

5. Grease all the grooves of the thread take-up cam ⑨ and the work clamp cam ⑩.

6. After greasing, assemble in the reverse order.

Note:

- When assembling the needle bar case ⑥, place it on the machine and turn the change pulley ⑫ behind the cover ⑪ at right. Check that it is engaged, and then tighten the bolts.

- When attaching the presser foot guide plate ⑧, move the presser foot up and down by the retracting lever to check that it is not distorted.

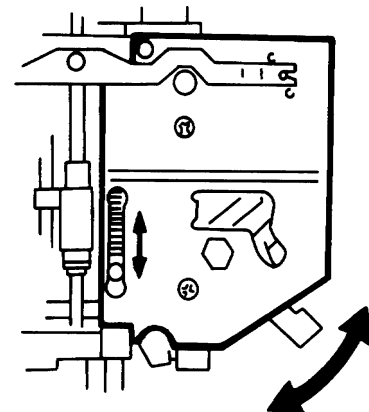

Grease the places indicated by the arrow once in six months.

Note:

When greasing, be sure to use the grease tank BR2 (black) provided with the machine.

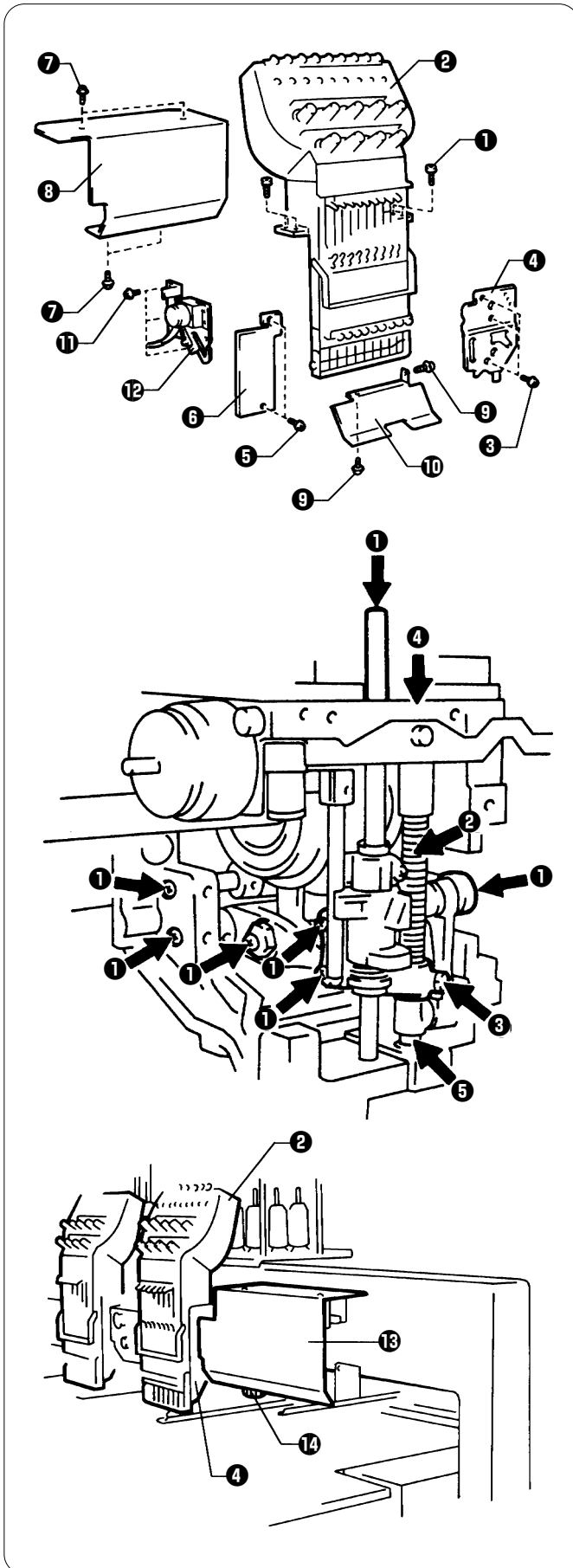

## BES-960BC

1. Remove two connectors from the rear of the needle bar case.
2. Loosen four bolts ①, and remove the needle case ②.
3. Loosen three screws ③, and remove the presser foot guide plate ④.
4. Loosen two screws ⑤, and remove the arm cover L ⑥.
5. Loosen four screws ⑦, and remove the head cover ⑧.
6. Loosen two bolts ⑨, and remove the cap eaves guide ⑩.
7. Loosen three bolts ⑪, and remove the wiper solenoid assembly ⑫.

8. Remove the screws at the places indicated by the arrow, insert grease into the tapped hole using the syringe. Then tighten the bolts.

9. After greasing, assemble in the reverse order.

Note:

- When assembling the needle bar case ②, place it on the machine and turn the change pulley ⑭ behind the cover ⑬ at right. Check that it is engaged, and then tighten the bolts.
- When attaching the presser foot guide plate ④, move the presser foot up and down by the retracting lever to check that it is not distorted.

BES-1260BC

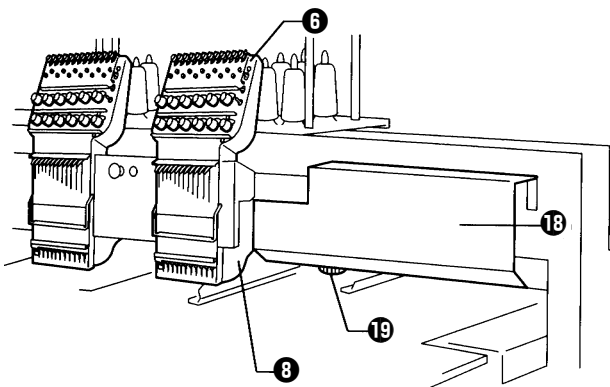
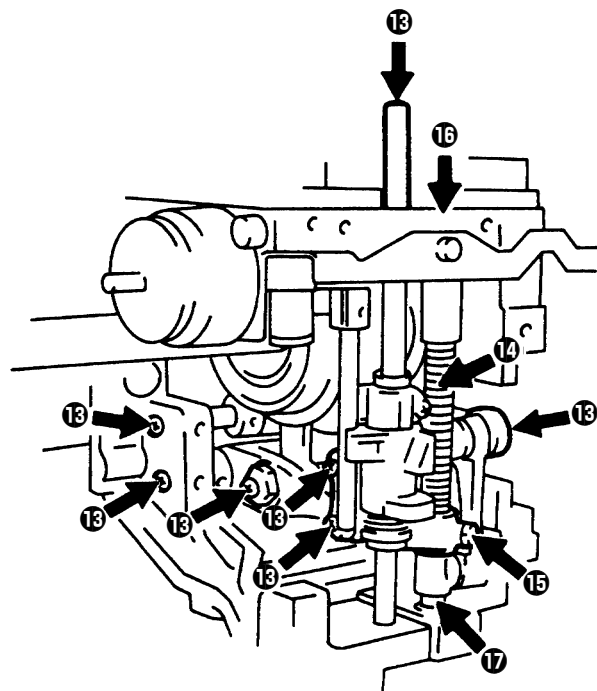
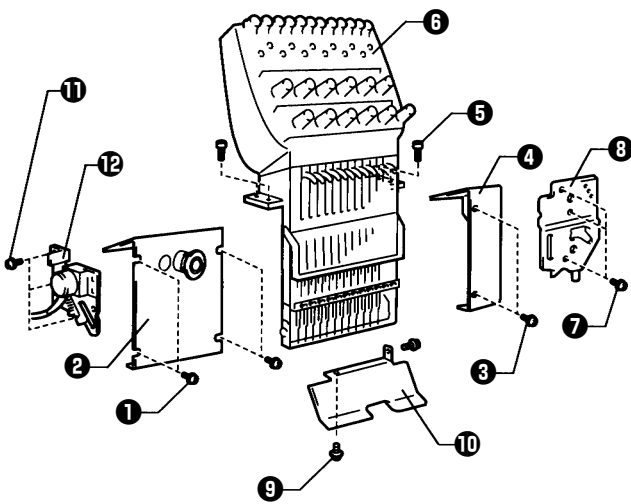

1. Remove two connectors from the rear of the needle bar case.

2. Loosen four screws ①, and remove the head cover ②, and loosen two screws ③ and remove the head cover R ④.

Note:

Because the heads No.1 and No.2 have the head covers R and L respectively, remove both the the covers when greasing.

3. Loosen four bolts ⑤, and remove the needle case ⑥.

4. Loosen three screws ⑦, and remove the presser foot guide plate ③.

5. Loosen two bolts ⑨, and remove the cap eaves guide ⑩.

6. Loosen three bolts ⑪, and remove the wiper solenoid assembly ⑫.

7. Remove the screws ⑬ at the places indicated by the arrow, insert grease into the tapped hole using the syringe. Then tighten the screws. Also grease the presser bar spring ⑭, the presser bar guide bracket ⑮, the presser bar metal U ⑯ and D ⑰.

8. After greasing, assemble in the reverse order.

Note:

- When assembling the needle bar case ⑥, place it on the machine and turn the change pulley ⑱ behind the cover ⑲ at right. Check that it is engaged, and then tighten the bolts.
- When attaching the presser foot guide plate ③, move the presser foot up and down by the retracting lever to check that it is not distorted.

## 3-2. Feed Guide Section

Check the X-feed linear guides (3 positions) and the Y-feed linear guides (one each on the right and left).

Note:

When greasing, be sure to use the grease tank 30 provided with the machine.

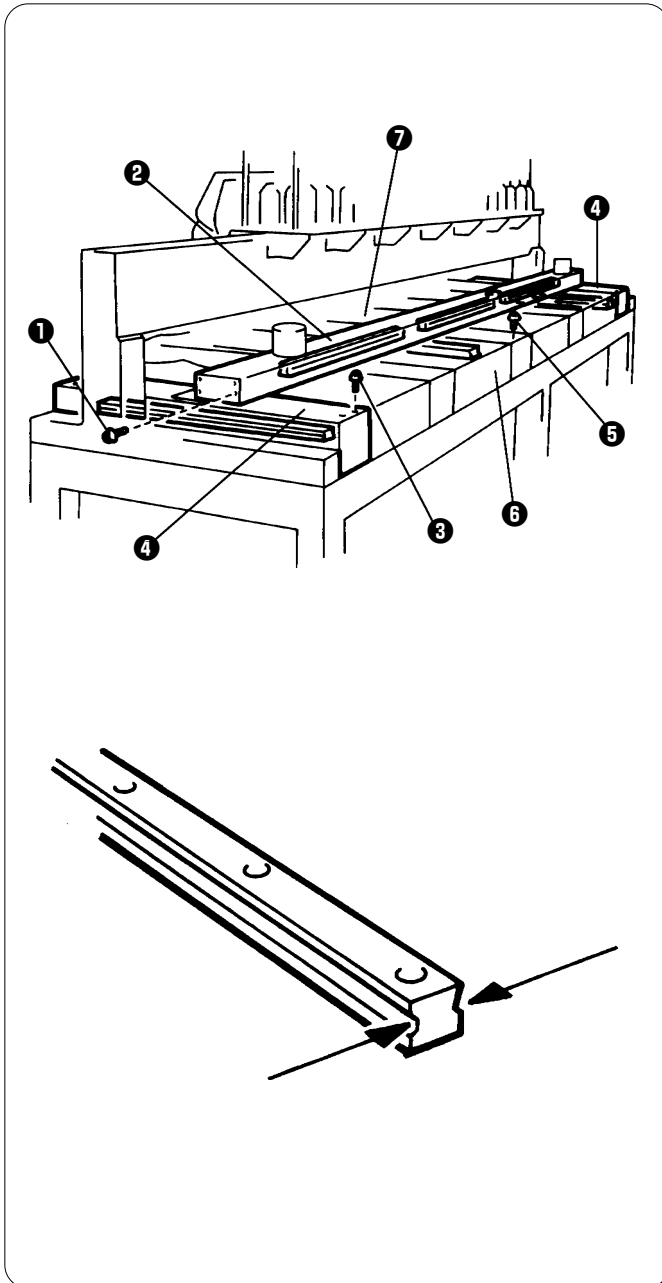

### Procedure

1. Loosen 12 screws **1**, and remove the X-feed cover **2**.
2. Loosen eight screws **3**, and remove the Y-feed cover **4** from the right and left.
3. Loosen 13 screws **5**, and remove the bed covers B **6** and C **7**.
4. Grease the X-feed linear guides (3 positions), the Y-feed linear guides (one each on the right and left), and the linear guide inside the No. 3 bed. Slide the guide to spread grease entirely.
5. After greasing, assemble in the reverse order.



# Chapter 7 Electric Components

## 1. PCBs locations

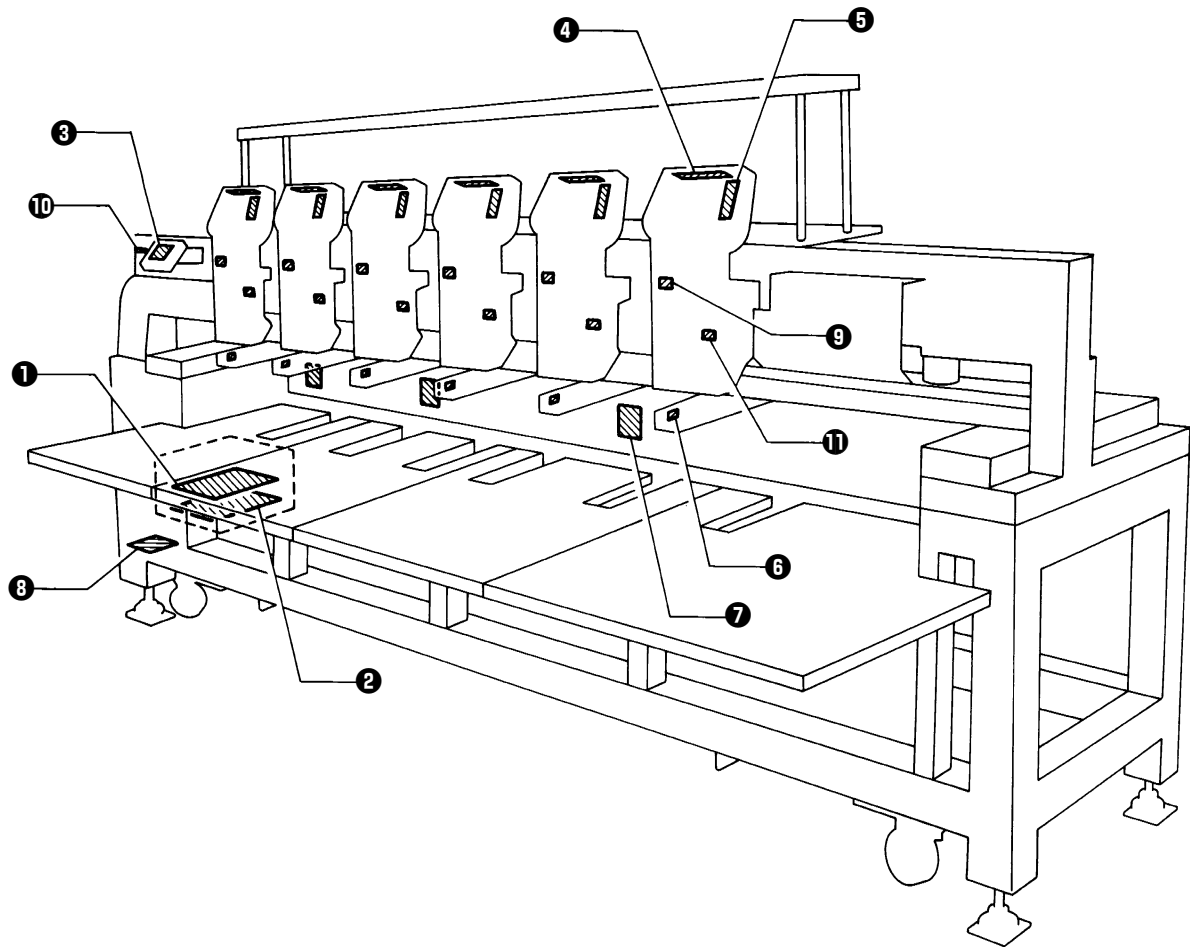

❶ Main PCB ❷ Power supply PCB in control box ❸ Panel PCB ❹ TR breakage sensor PCB ❺ Head switch PCB ❻ BC sensor PCB ❼ BC PCB ❽ Power supply PCB B (in power supply base) ❾ Sensor PCB ❿ Sensor PCB ⓫ Switch assy

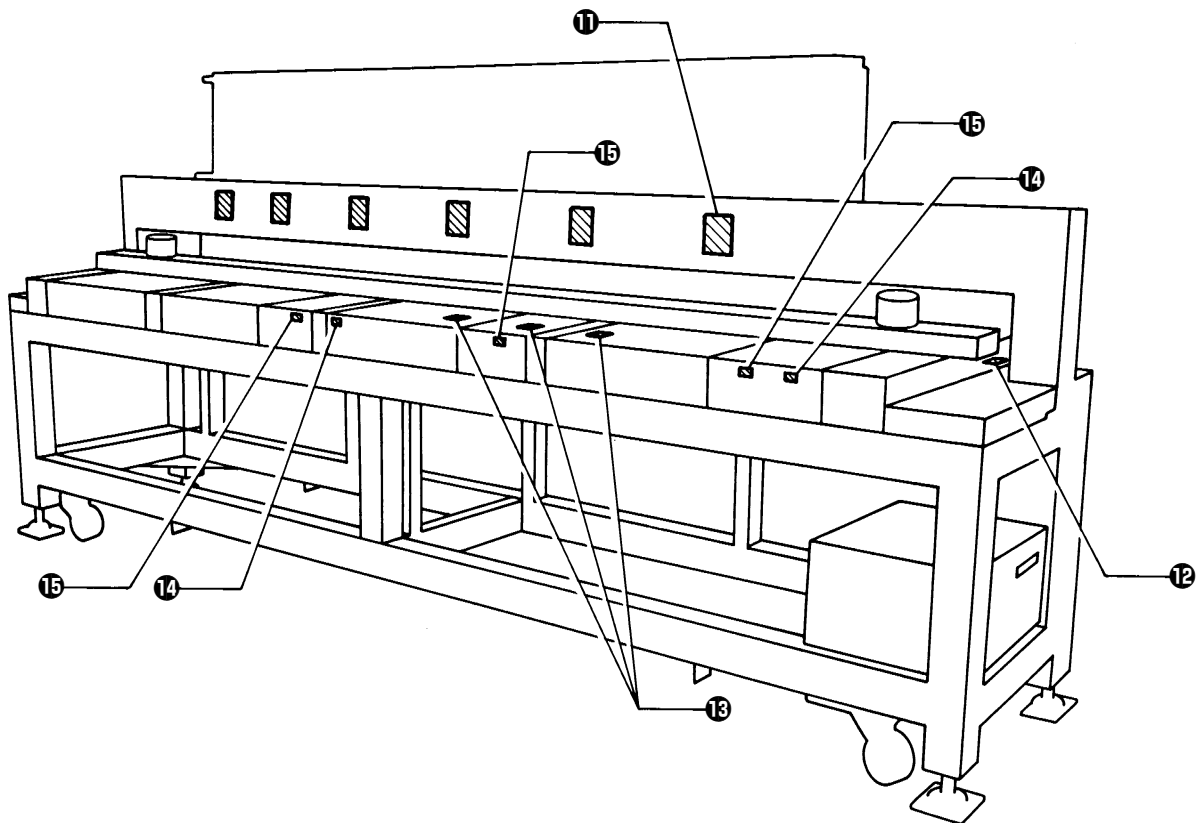

11 Head PCB 12 Y feed sensor PCB 13 X feed sensor PCB 14 Thread trimming sensor PCB 15 Retracting bed sensor PCB

**! DANGER**



Wait at least 5 minutes after turning off the power switch and disconnecting the power cord from the wall outlet before opening the face plate of the control box. Touching areas where high voltages are present can result in severe injury.

**Note:**

Before replacing or adjusting any PCB in the control box, be sure to turn off the power and remove the power supply plug from the socket.

## 2. Replacing the PCBs in the control box

### 2-1. Removing and reattaching the control box

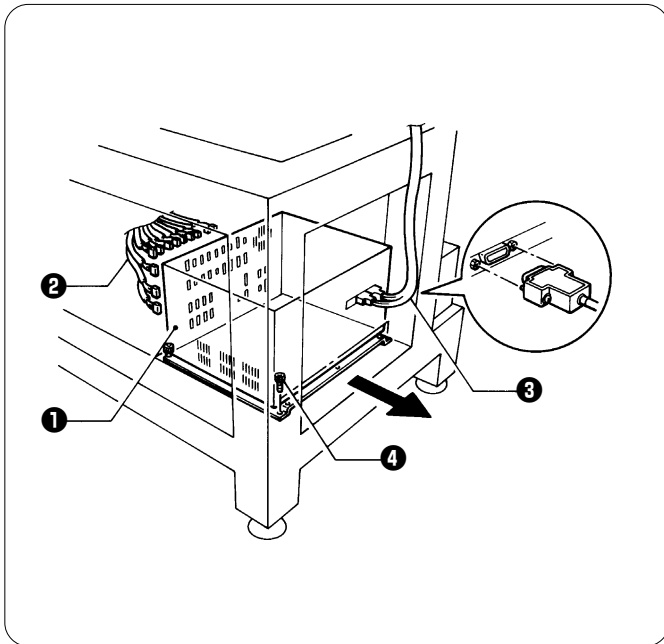

1. Remove all connectors **2** from the rear of the control box **1**.
2. Loosen the two screws of the cable **3** to remove its connector.
3. Remove the four bolts **4** to separate the control box **1** from the machine.
- Reverse the above procedure for re-assembly.

### 2-2. Removing and reattaching the control box cover

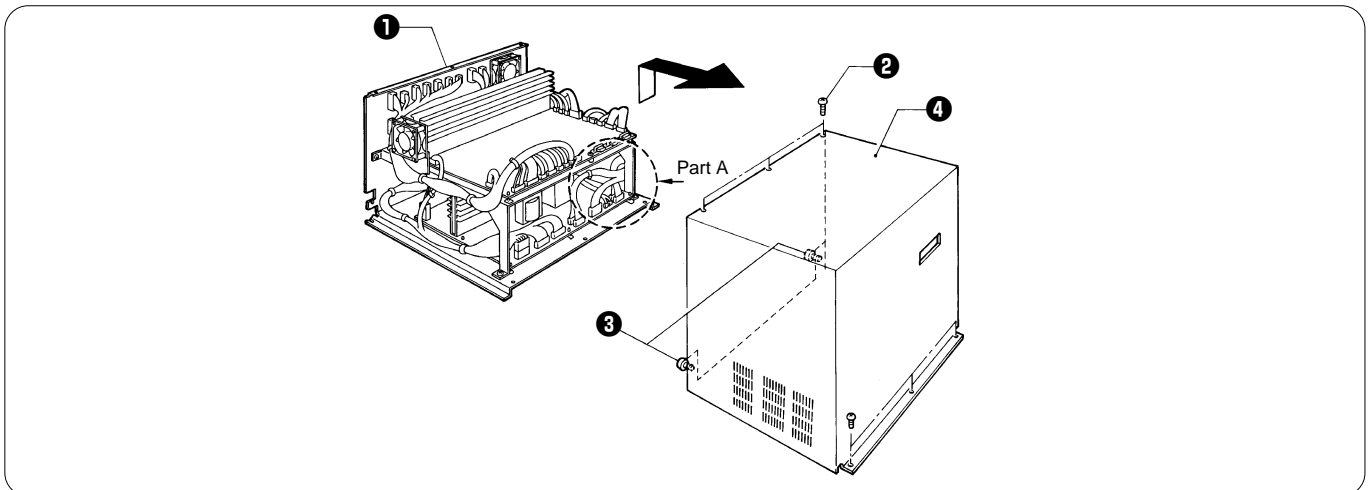

1. Remove the eight screws **2** from the control box **1**. (Loosen the two screws **3**.)
2. Remove the control box cover **4** by lifting it a little and pulling toward the front.  
Pay attention not to cut any harnesses wired inside the control box especially around part A.
- Reverse the above procedure for re-assembly.

## 2-3. Replacing the main PCB

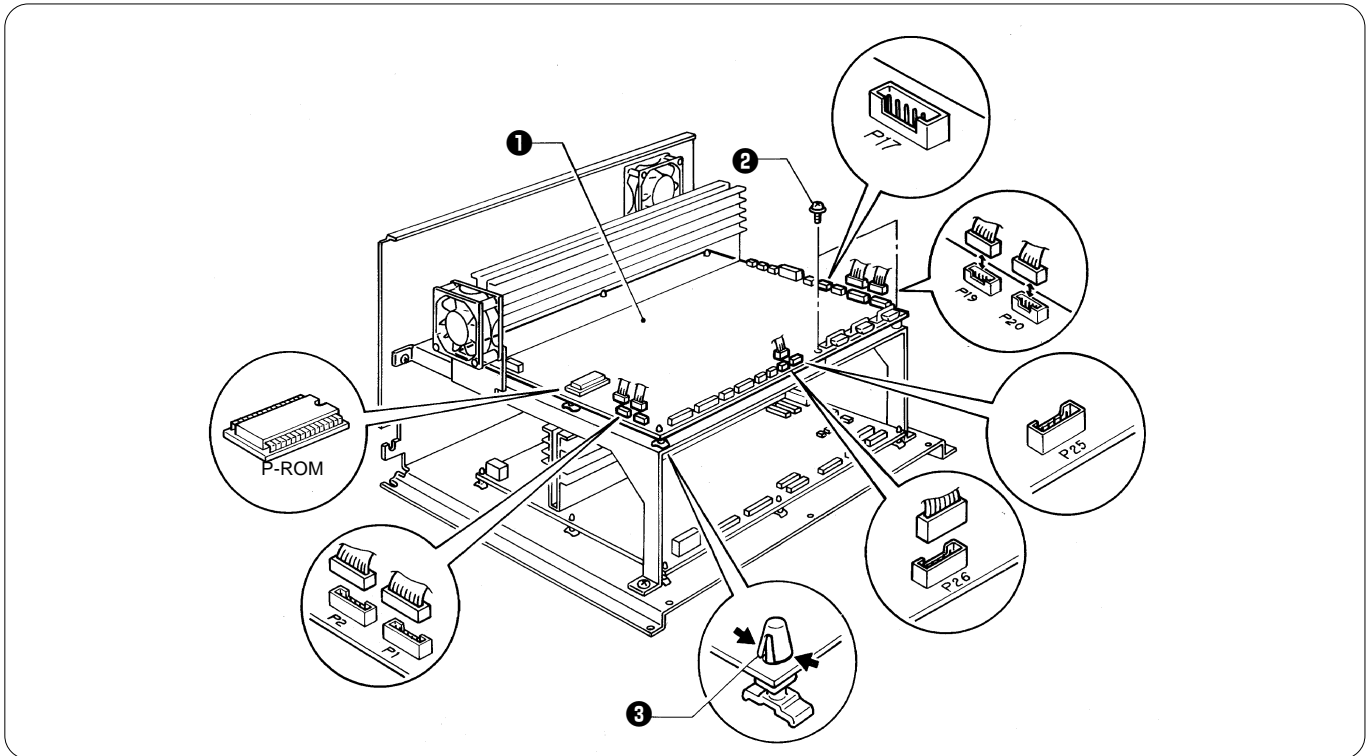

1. Remove all connectors from the main PCB ❶.
2. Remove the two screws ❷ and then separate the main PCB ❶ from the control box by pressing the clamps of the four PCB supports ❸ inward.
- Reverse the above procedure for re-assembly.

### Notes:

- When reattaching connectors, support the rear of the main PCB ❶, and insert them without excessive force.
- When removing and reattaching connectors, do not pull on the cables; hold the connectors. Especially for connectors P1, P2, P19, P20, and P26, hold them straight so as not to apply any force to their surroundings.
- Treat PCBs carefully as ICs in the PCBs are easily damaged by static electricity. Also, do not touch the IC pins.
- Connectors P17 and P25 are unused and are not connected to cables.
- Make sure the replaced PCBs and the P-ROM chips are mounted.

## 2-4. Replacing the power supply PCB

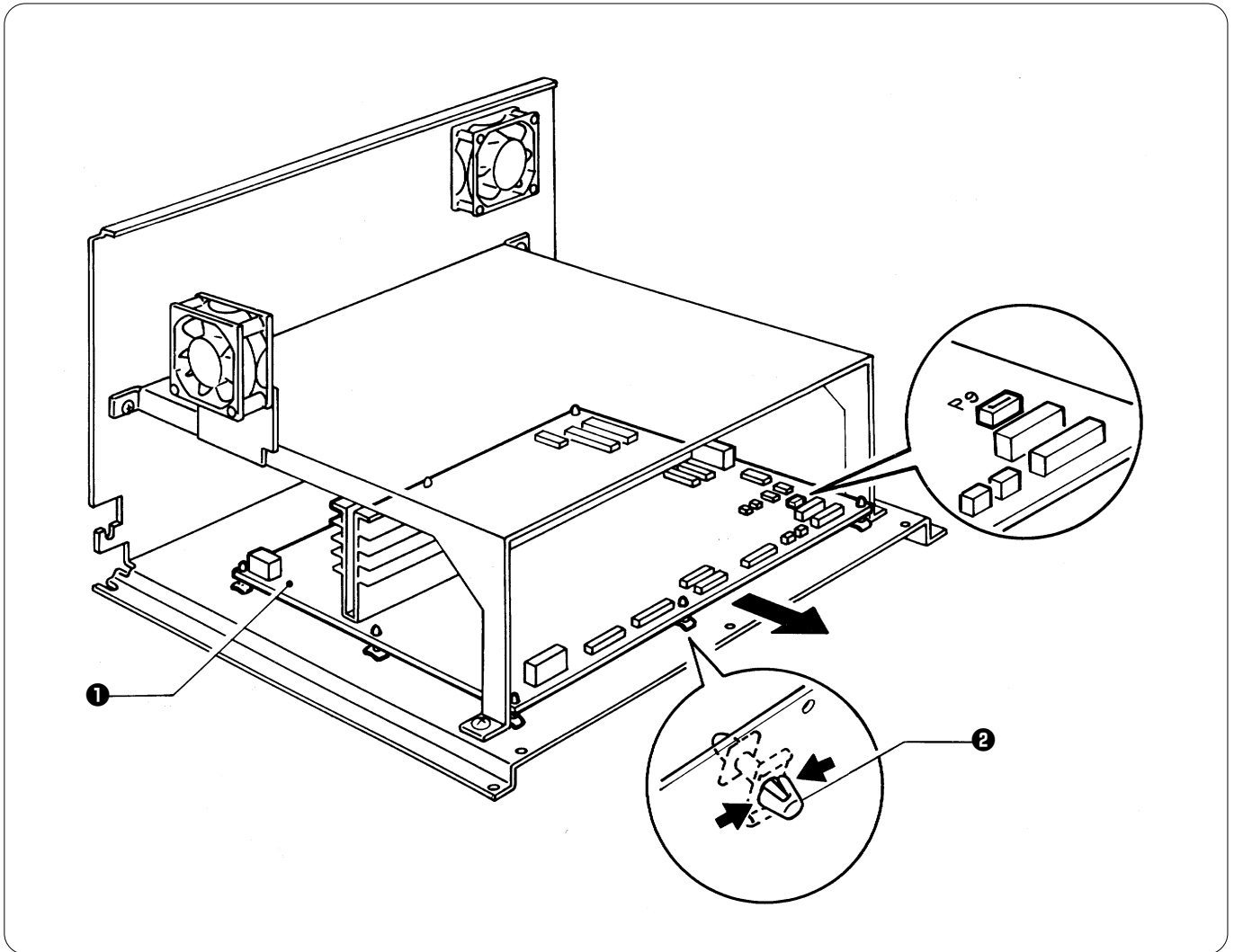

1. Remove all connectors from the power supply PCB ❶.
2. While pressing the clamps of the nine supports ❷ inward from the bottom of the control box, remove the power supply PCB ❶ and supports ❷ from the control box.
3. Remove the supports ❷ from the power supply PCB ❶, and attach them to the power supply PCB to be replaced.
4. Match the supports ❷ with the holes on the bottom of the control box, and attach the power supply PCB to the control box by pressing each support.

### Notes:

- When reattaching connectors, support the rear of the power supply PCB ❶, and insert them without excessive force.
- When removing and reattaching connectors, do not pull on the cables; hold the connectors.
- Treat PCBs carefully as ICs in the PCBs are easily damaged by static electricity. Also, do not touch the IC pins.
- When removing the PCB, turn off the power, leave it as it is for at least 5 minutes, and make sure that electrical charge of the capacitor on the PCB has been released.
- Since an electrical charge may remain in the removed power supply PCB, do not touch the bottom (soldered surface) of the board and anything lead in part. As well, pay attention not to cause a short by putting the board on anything metal.
- Connector P9 is unused and not connected to a cable.

### 3. Replacing power supply PCB B in the power supply base

#### 3-1. Removing and attaching the leg cover and the power supply base cover

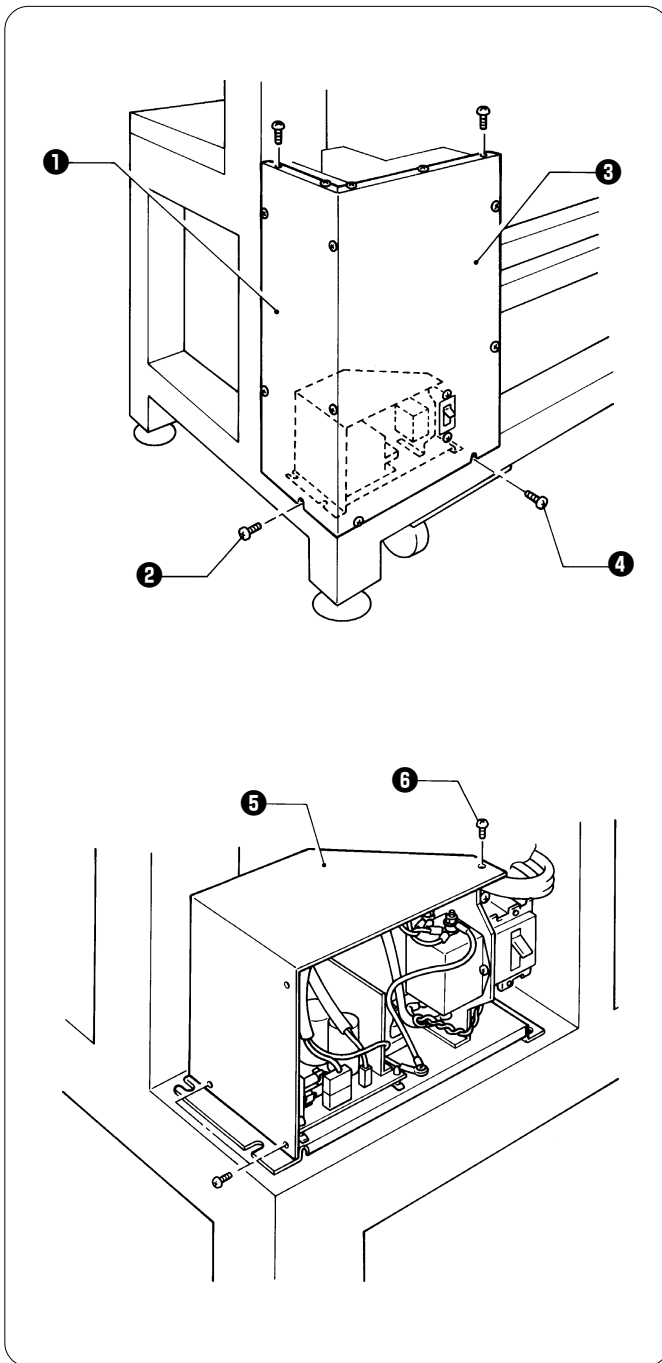

1. Remove the seven screws **2** on the top and side of motor cover L **1**, and then separate it from the machine leg.

2. Remove the seven screws **4** on the top and side of motor cover F **3**, and then separate it from the machine leg.

3. Remove the three screws **6**, and the power base cover **5**.  
 • Reverse the above procedure for re-assembly.

### 3-2. Replacing power supply PCB B in the power supply base

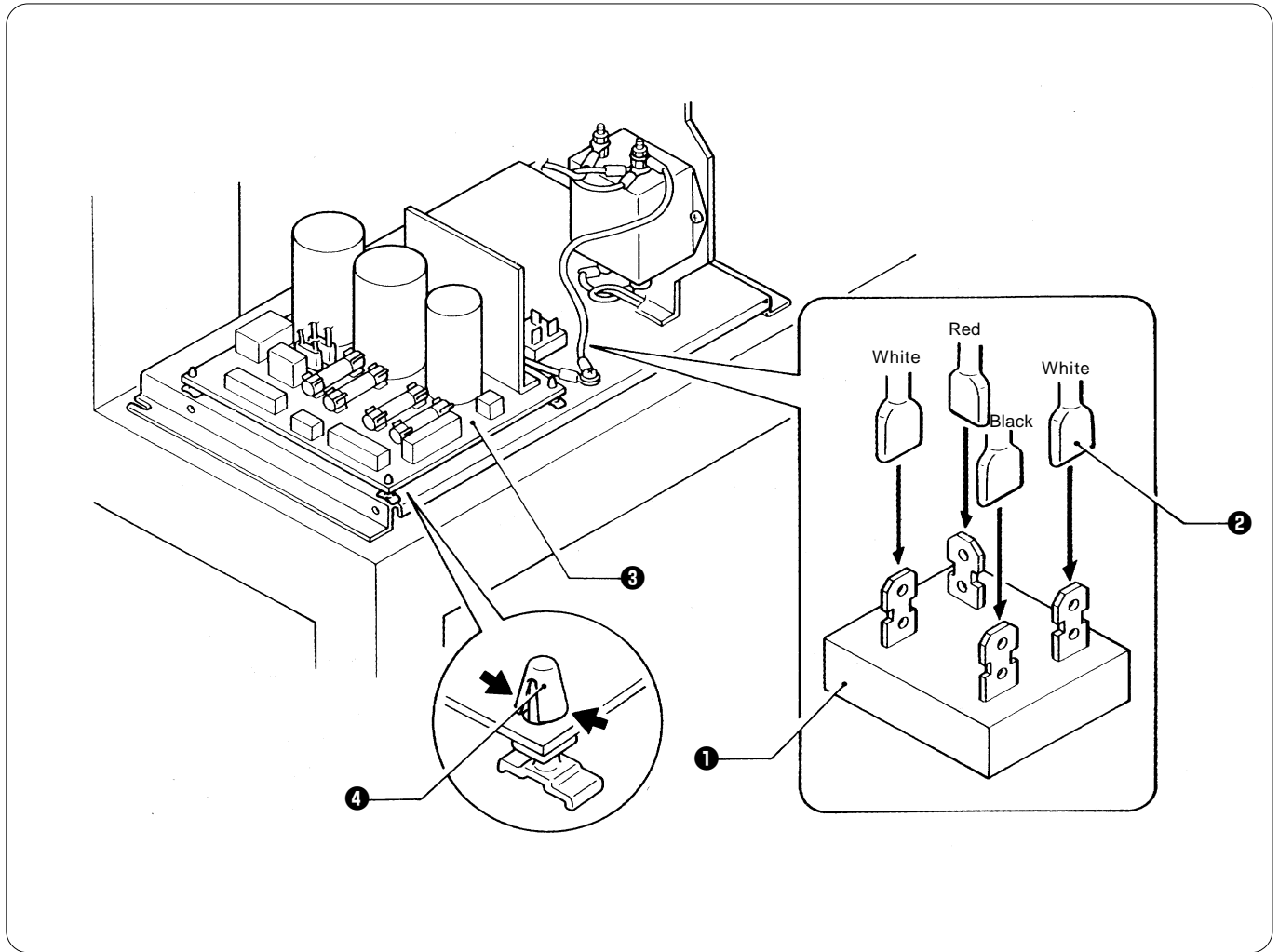

1. Remove the four faston receptacles ② from the bridge diode ①.
2. Remove all connectors from power supply PCB B ③.
3. Remove power supply PCB B ③ while pressing the clamps of the four supports ④ inward, and replace it with a new one.
- Reverse the above procedure for re-assembly.

Notes:

- When removing and reattaching connectors, do not pull on the cables; hold the connectors.
- When attaching the faston receptacles, refer to figure A; attach them to their respective positions according to the color of each lead wire.
- When removing the PCB, turn off the power, leave it as it is for at least 5 minutes, and make sure that electrical charge of the capacitor on the PCB has been released.
- Since an electrical charge may remain in the removed power supply PCB, do not touch the bottom (soldered surface) of the board and anything lead in part. As well, pay attention not to cause a short by putting the board on anything metal.

## 4. Replacing the head switch PCB on the adjustment base

### 4-1. Removing and reattaching the adjustment base cover

BES-960BC

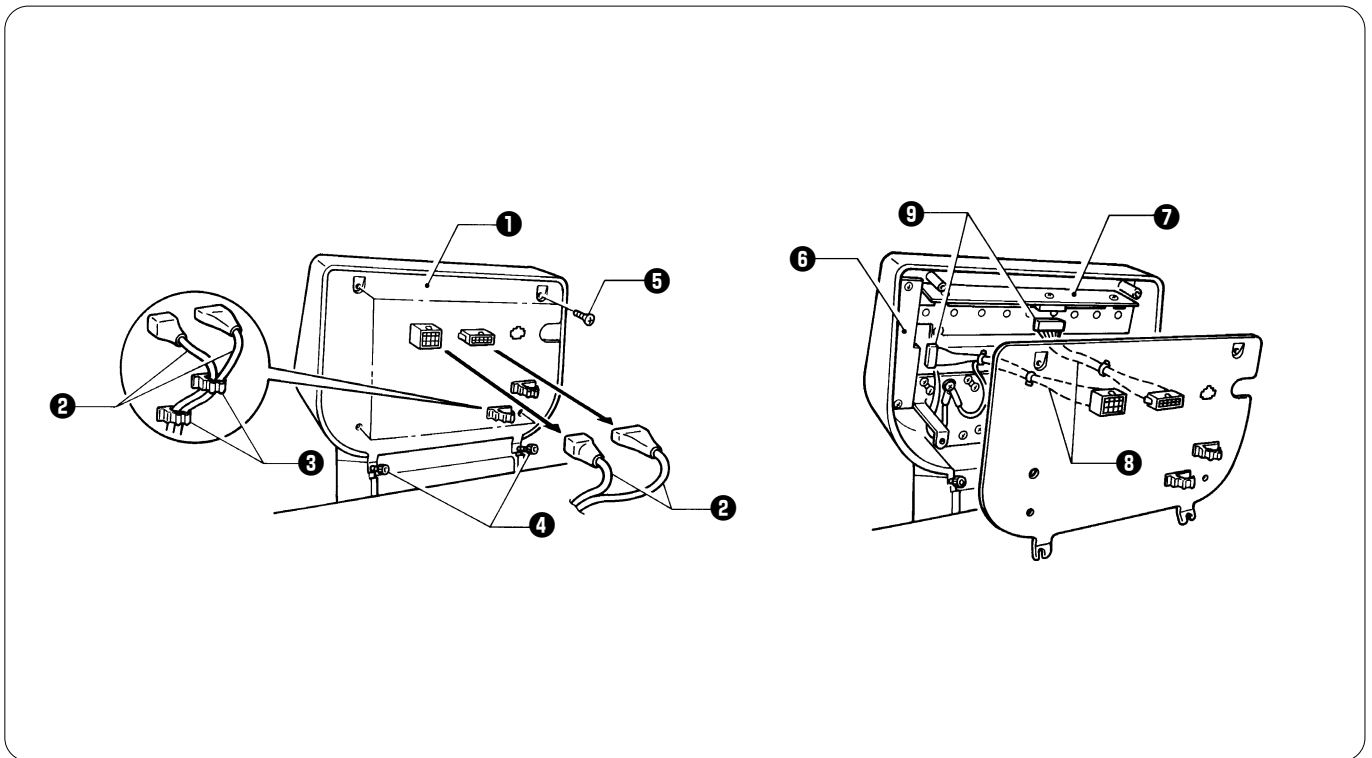

1. Remove the two connectors **2** from the adjustment base cover **1**. Unlock the cord holders **3** and remove the cables.
  2. Loosen the two bolts **4** of the adjustment base cover **1**.
  3. Remove the four screws **5**, and the adjustment base cover **1**.  
Inside of the adjustment base cover **1**, the two harnesses **8** are connected to the head switch PCB **6** and the TR breakage sensor PCB **7**. Remove the two connectors **9** from the head switch PCB **6** and the TR breakage sensor PCB **7**.
- Reverse the above procedure for re-assembly.

**Note:**

If the harnesses of the connectors **2** are not fixed by the cord holders **3** after reattachment, the harnesses may make contact with the driving shaft of the needle bar case.



## BES-1260BC

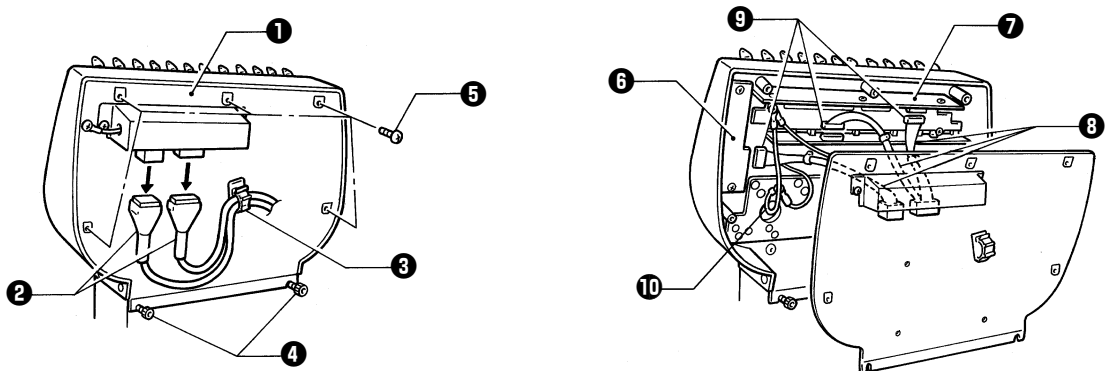

1. Remove the two connectors **2** from the adjustment base cover **1**. Unlock the cord holders **3** and remove the cables.
  2. Loosen the two bolts **4** of the adjustment base cover **1**.
  3. Remove the six screws **5** (one is for attaching the ground wire ), and the adjustment base cover **1**. Inside of the adjustment base cover **1**, the three harnesses **8** are connected to the head switch PCB **7** and the TR breakage sensor PCBs **7**. Remove the three connectors **10** from the head switch PCB **6** and the TR breakage sensor PCBs **7**.
- Reverse the above procedure for re-assembly.

## Note:

- Attach the blue connector to the upper TR breakage sensor PCB **7**, and the white connector to the lower one.
- If the harnesses of the connectors **2** are not fixed by the cord holders **3** after reattachment, the harnesses may make contact with the driving shaft of the needle bar case.
- Be sure to reattach the ground wire **10**.

## 4-2. Replacing the head switch PCB

BES-960BC

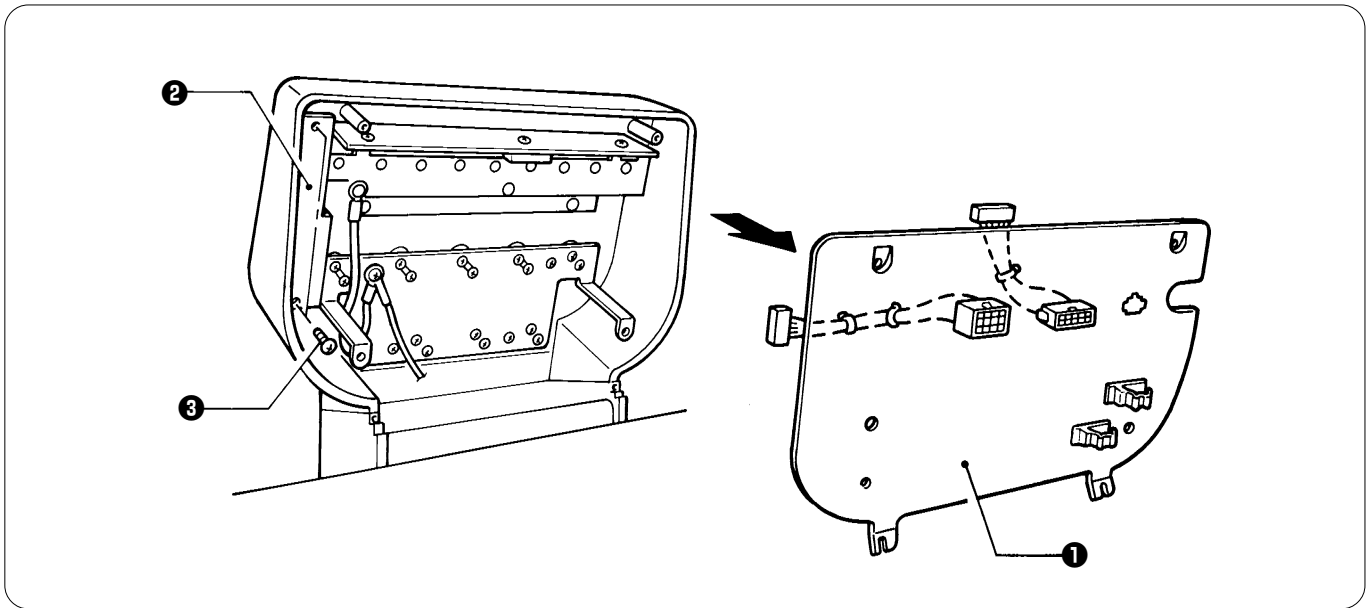

BES-1260BC

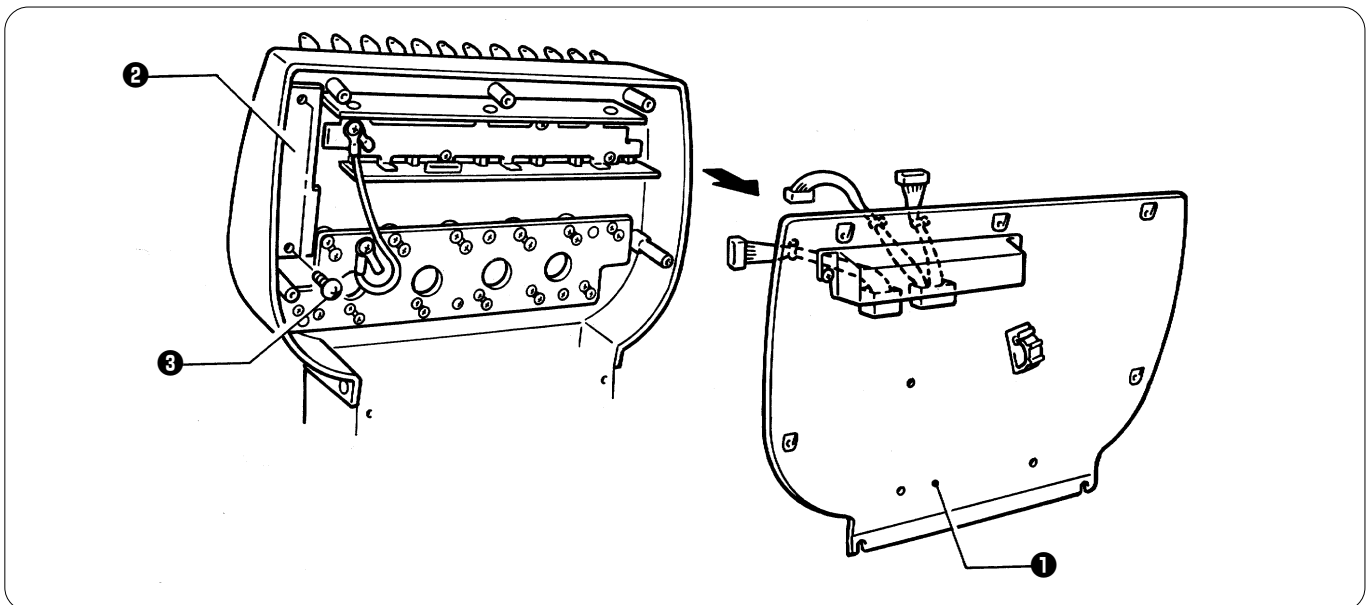

1. Remove the adjustment base cover ①.  
Note:  
Refer to 4-1 for details.
2. Remove the two screws ③ securing the head switch PCB ②.
3. Remove the head switch PCB ②.  
Reverse the above procedure for re-assembly.

## 4-3. Removing the TR breakage sensor PCB

BES-960BC

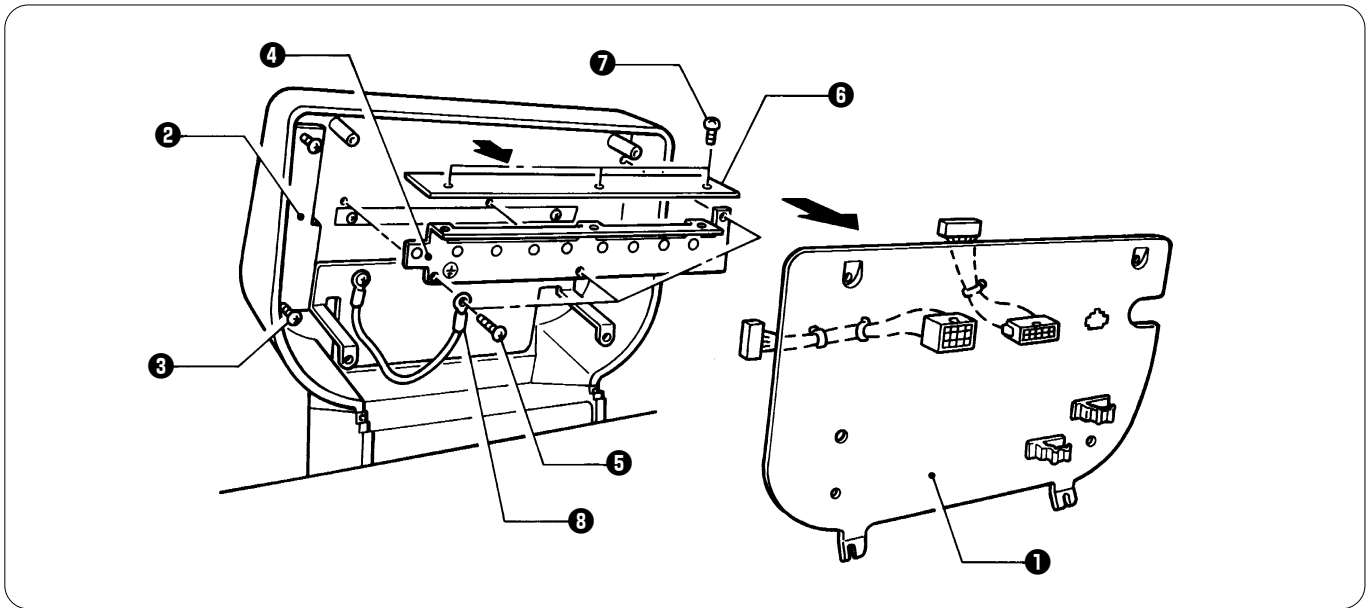

1. Remove the adjustment base cover **1**.

Note:

Refer to 4-1 for details.

2. Loosen the two screws **3** securing the head switch PCB **2**.
3. Remove the three screws **5** securing the thread breakage plate **4**.
4. Remove the thread breakage plate **4** and the TR breakage sensor PCB **6** from the adjustment base cover **1**.
5. Remove the three screws **7** securing the thread breakage plate **4** to the TR breakage sensor PCB **6**.
6. Remove the TR breakage sensor PCB **6**.

Reverse the above procedure for re-assembly.

Note:

Attach the ground wire **8** to the thread breakage plate **4** using the screw **5**.

After replacing the PCB, be sure to attach the ground wire and connectors.

When removing and reattaching connectors, do not pull on the cables; hold the connectors.

When removing the TR breakage sensor PCB **6** and the thread breakage plate **4**, do not make contact with the head switch PCB **2**.

BES-1260BC

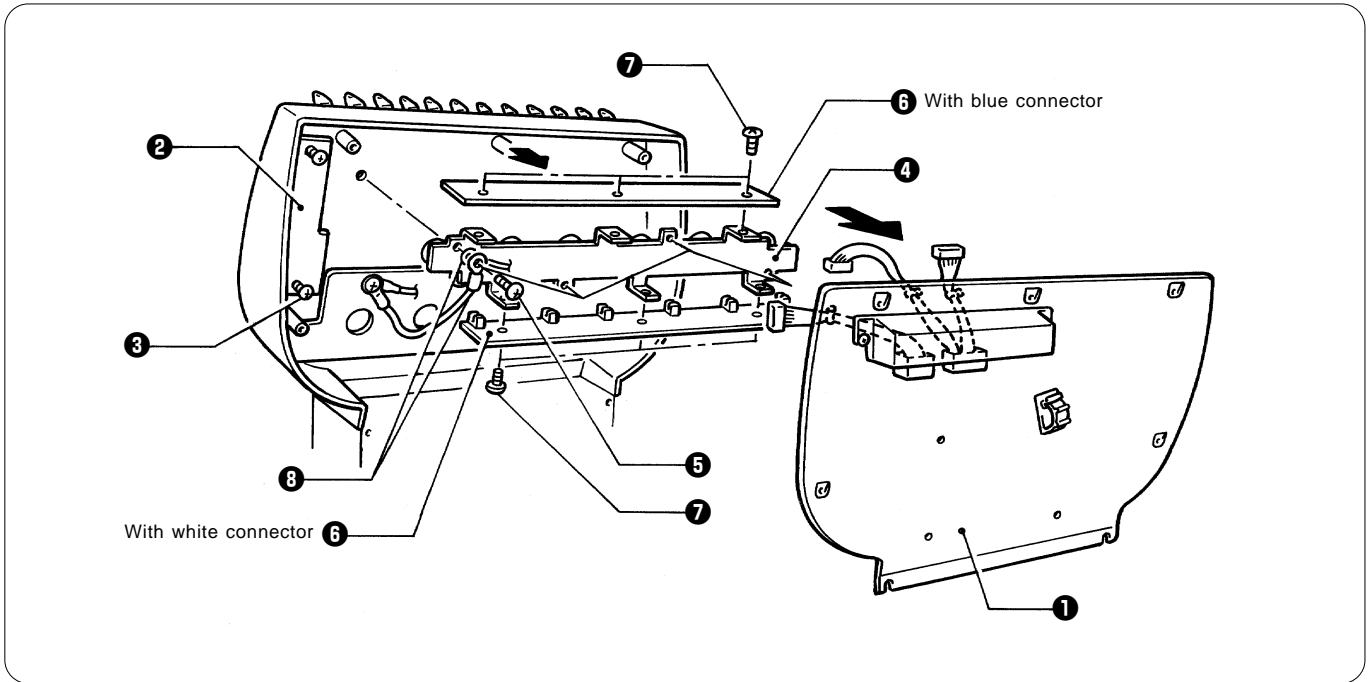

1. Remove the adjustment base cover ①.

Note:

Refer to 4-1 for details.

2. Loosen the two screws ③ securing the head switch PCB ②.
3. Remove the four screws ⑤ securing the thread breakage plate ④.
4. Remove the thread breakage plate ④ and the TR breakage sensor PCBs ⑥ from the adjustment base cover ①.
5. Remove the six screws ⑦ securing the TR breakage sensor PCBs ⑥ to the thread breakage plate ④.
6. Remove the TR breakage sensor PCBs ⑥.

- Reverse the above procedure for re-assembly.

Note:

- Attach the ground wire ⑧ to the thread breakage plate ④ using the screw ⑤.
- After replacing the PCB, be sure to attach the ground wire ⑧ and connectors.
- When removing and reattaching connectors, do not pull on the cables; hold the connectors.
- When removing the TR breakage sensor PCBs ⑥ and the thread breakage plate ④, do not make contact with the head switch PCB ②.
- The blue and the white connectors are attached to the upper and lower TR breakage sensor PCBs ⑥, respectively.

## 5. Replacing the head PCB

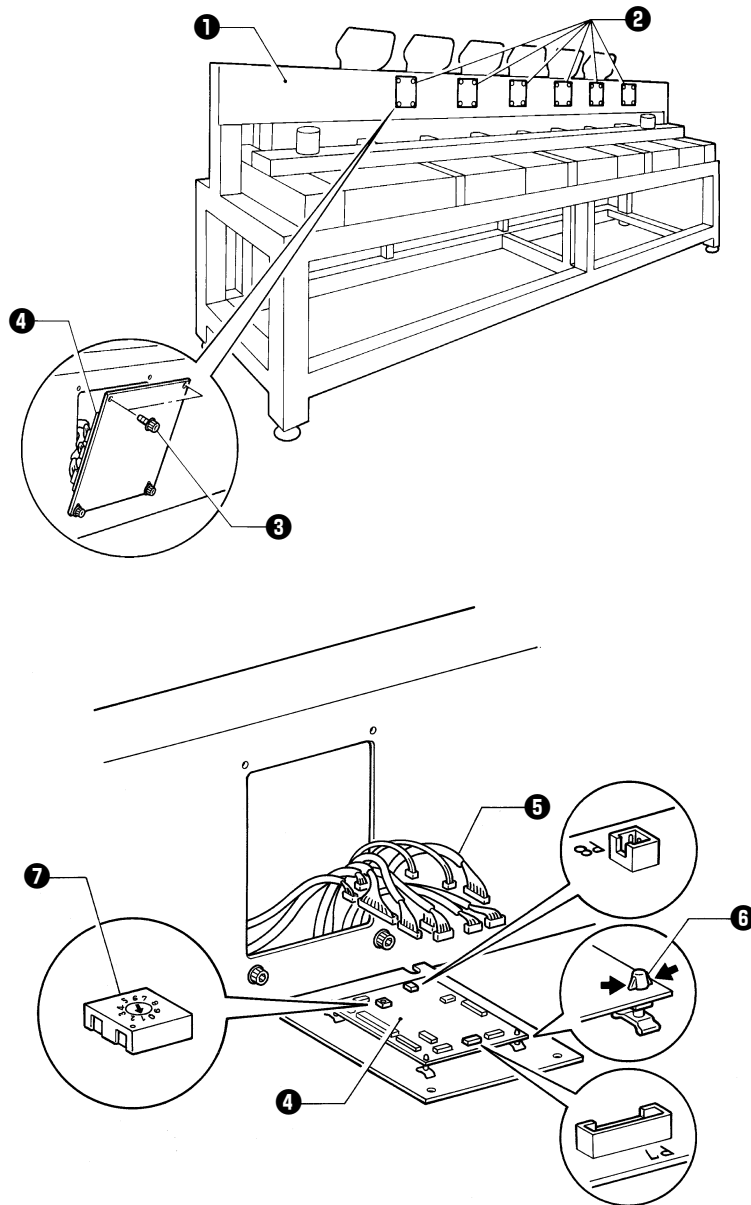

1. Remove the two upper bolts **3** of the bridge cover **2**. (Just loosen the lower bolts.)
  2. Remove the bridge cover **2**. The head PCB **4** is attached to the inside of the bridge cover **2**.  
 Note:  
 The head PCB **4** has the connectors **5** on it. Handle it carefully so as not to damage any wires nor apply excessive force.
  3. Remove connectors **5** from the head PCB **4**.
  4. Remove the head PCB **4** by pressing the clamps of the four supports **6** inward, and replace it with a new one.
- Reverse the above procedure for re-assembly.
- Notes:
- When removing and reattaching connectors, do not pull on the cables; hold the connectors.
  - When attaching the head PCB **4**, set the rotary switch **7** on the head PCB **4** to the head number.
  - Connectors P7 on the head, except for no.1, are unused and not connected to a cable.
  - Connector P8 is unused and not connected to cable.

## 6. Replacing the BC PCB

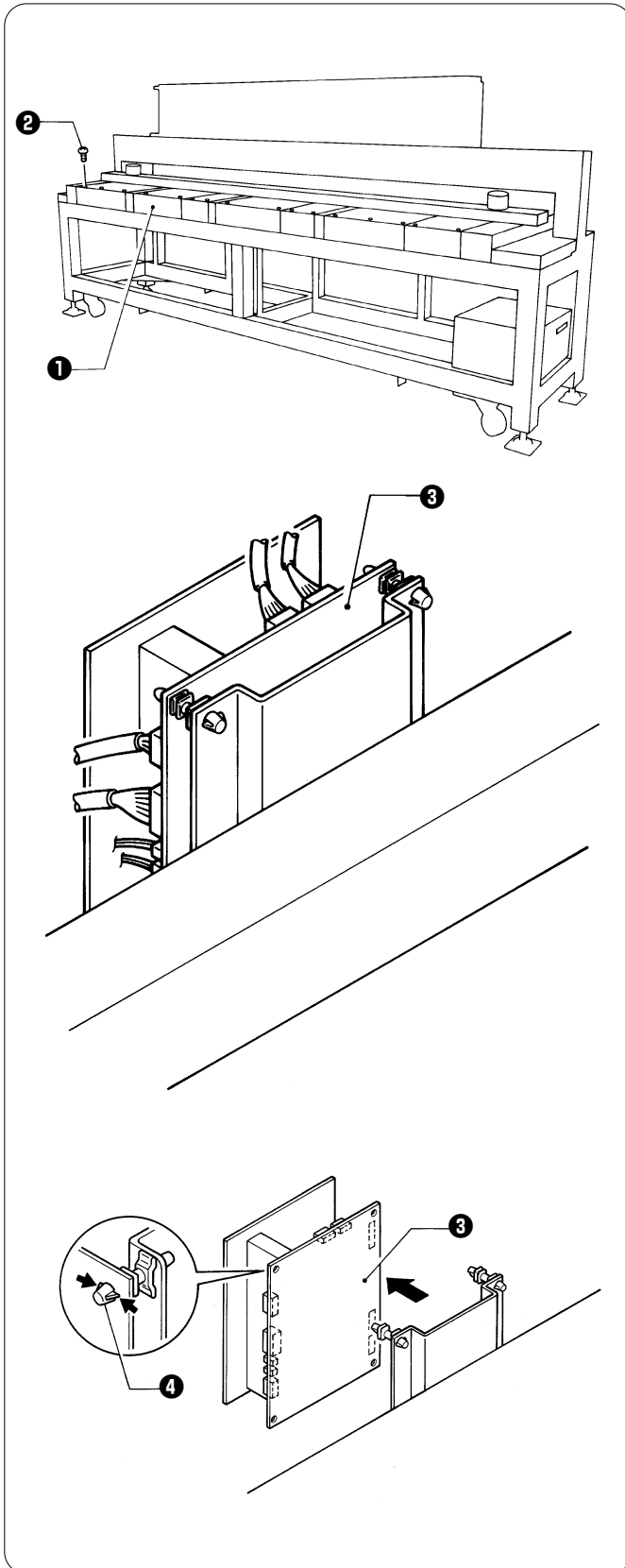

1. Remove the eight screws **2**, and the table cover **1** upward.

2. Remove all connectors from the BC PCB **3**.

3. Remove the BC PCB **3** by pressing the clamps of the four supports **4** inward, and replace it with a new one. Reverse the above procedure for re-assembly.

Notes:

Pay close attention to the handling of the PCB.

## 7. Replacing the BC sensor PCB

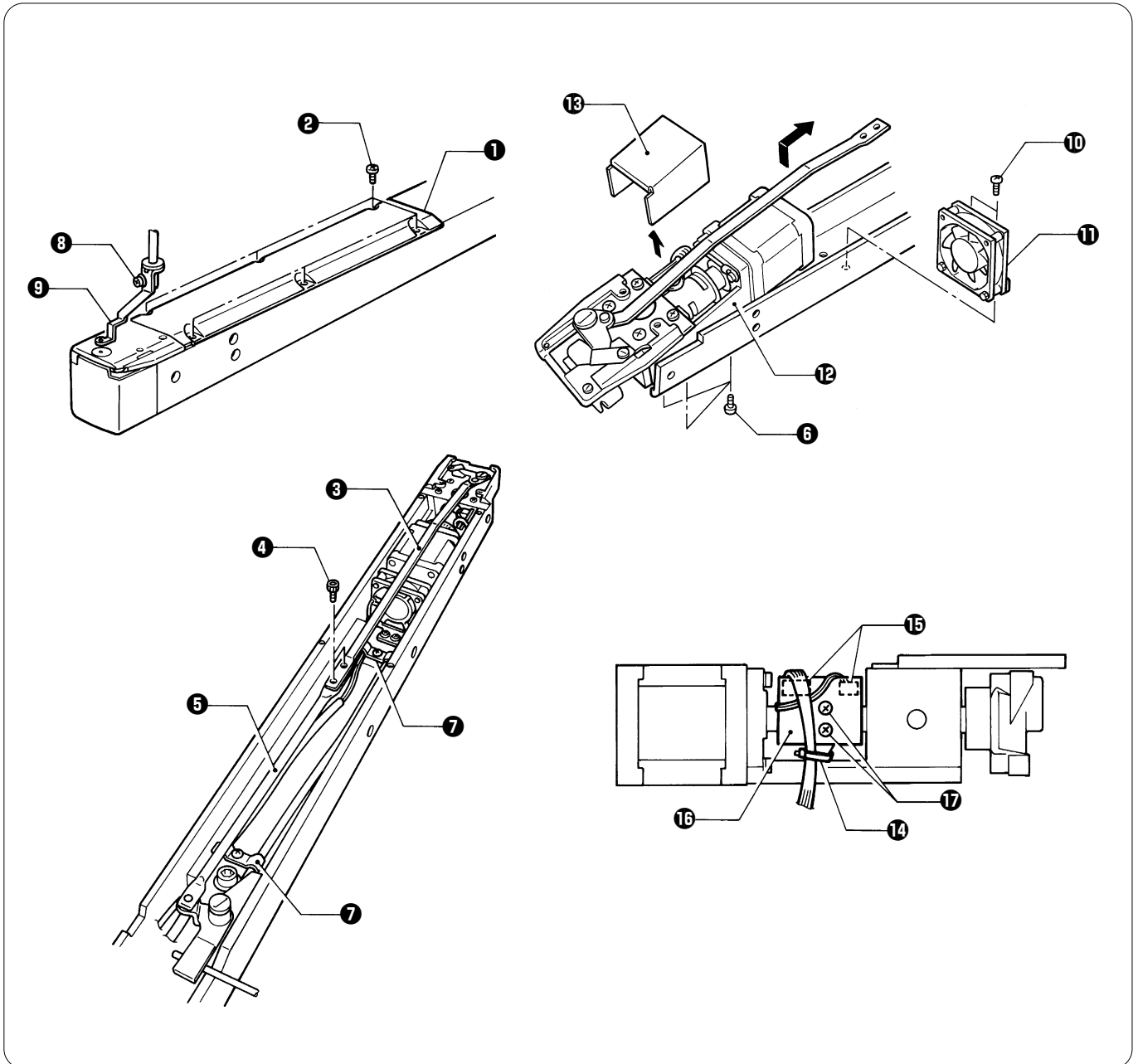

1. Remove the six screws **2** and the bed cover **1**.
2. Remove the two bolts **4** and separate connecting rod B **3** from connecting rod C **5**.
3. Remove the three screws **6** from the lower shaft module.
4. Remove the two cord clamps **7**.
5. Remove the screws **8** and separate the presser foot **9**.
6. Remove the two screws **10**, and the fan **11** from the bed.
7. Lift the lower shaft module **12** at the rear, and pull it backward as shown in the figure.
8. Remove the lower shaft case cover **13**.
9. Cut the band **14**, and remove the two connectors **15**.
10. Remove the two screws **17**, and replace the BC sensor PCB **16** with a new one.
  - Reverse the above procedure for re-assembly.

### Notes:

- When removing and reattaching connectors, do not pull on the cables; hold the connectors.
- Refer to chapter 2, "14. Replacing and adjusting the lower shaft module" for checking the needle penetration point.
- Refer to chapter 2, "13. Replacing and adjusting the movable and fixed knives" for adjusting the movable knife.

## 8. Replacing the panel PCB

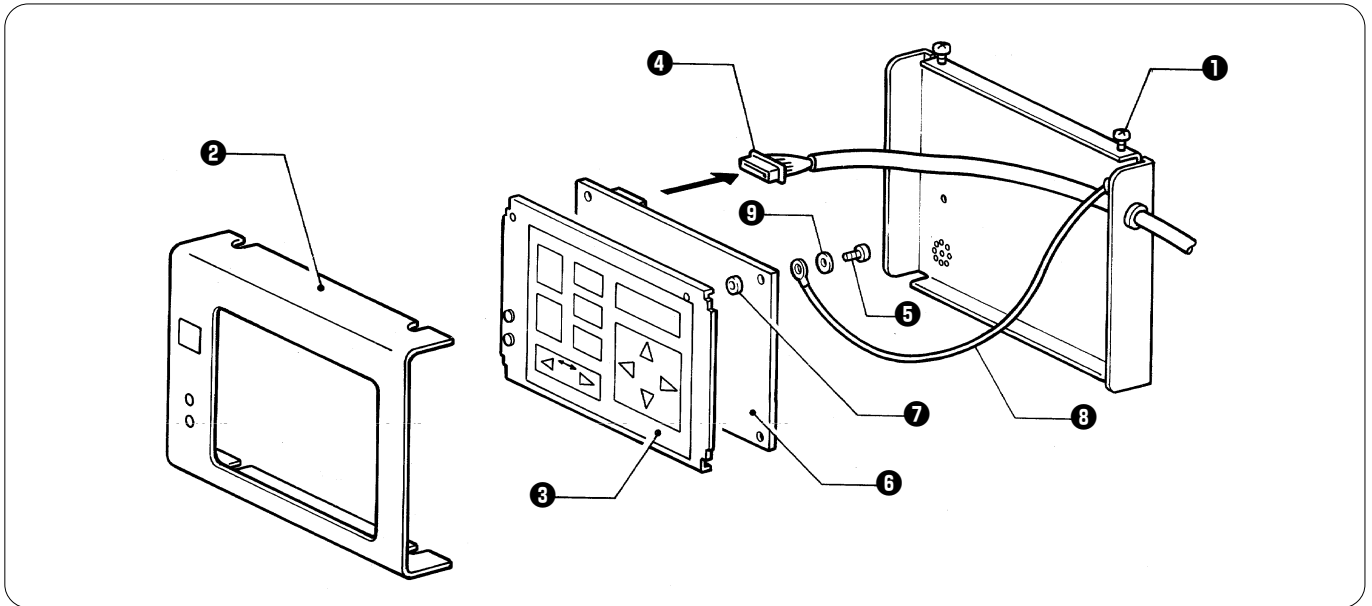

1. Loosen the four screws ① securing the operation panel at the top and bottom, and remove the panel cap ② by lifting it.
2. Separate the sheet holder plate ③ slowly, and remove the connector ④ from the rear of the panel PCB.
3. Remove the five screws ⑤ from the rear of the PCB, and replace the panel PCB ⑥ with a new one.
- After replacing the panel PCB, reverse the above procedure for re-assembly.

### Notes:

- After replacing the panel PCB, be sure to attach the ground wire and connector.
- When removing and reattaching connectors, do not pull on the cables; hold the connectors.
- Do not lose the collar ⑦ which is to be placed between the shaft holder plate ③ and the panel PCB ⑥.
- Attach the ground wire ⑧ to the panel PCB ⑥ using the screw ⑤ and the plain washer ⑨. As to the remaining three holes, insert screws with two plain washers on each. Pay attention to the number of plain washers as they influence the position of the holes.



## 9. Replacing the Y-feed sensor PCB

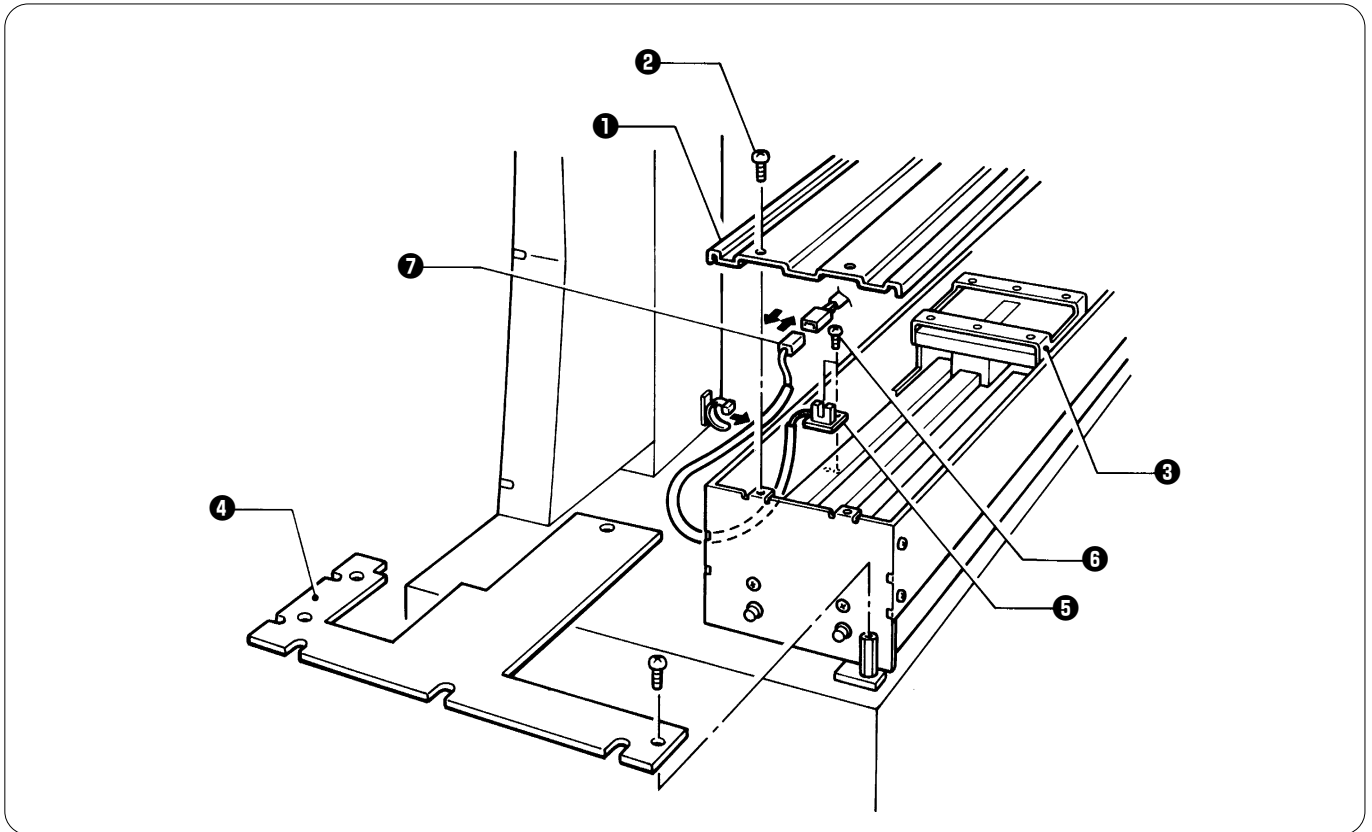

1. Remove the four screws ②, and separate Y-feed cover U ① from the Y carriage ③ slowly.
  2. Remove the four screws, and side cover LF ④.
  3. Remove the two screws ⑥, and the connector ⑦, and replace the Y-feed sensor PCB ⑤.
- Reverse the above procedure for re-assembly.

Notes:

- When removing and reattaching connectors, do not pull on the cables; hold the connectors.
- Do not forget to attach the spacer to the bottom of the PCB.

## 10. Replacing the X-feed sensor PCB

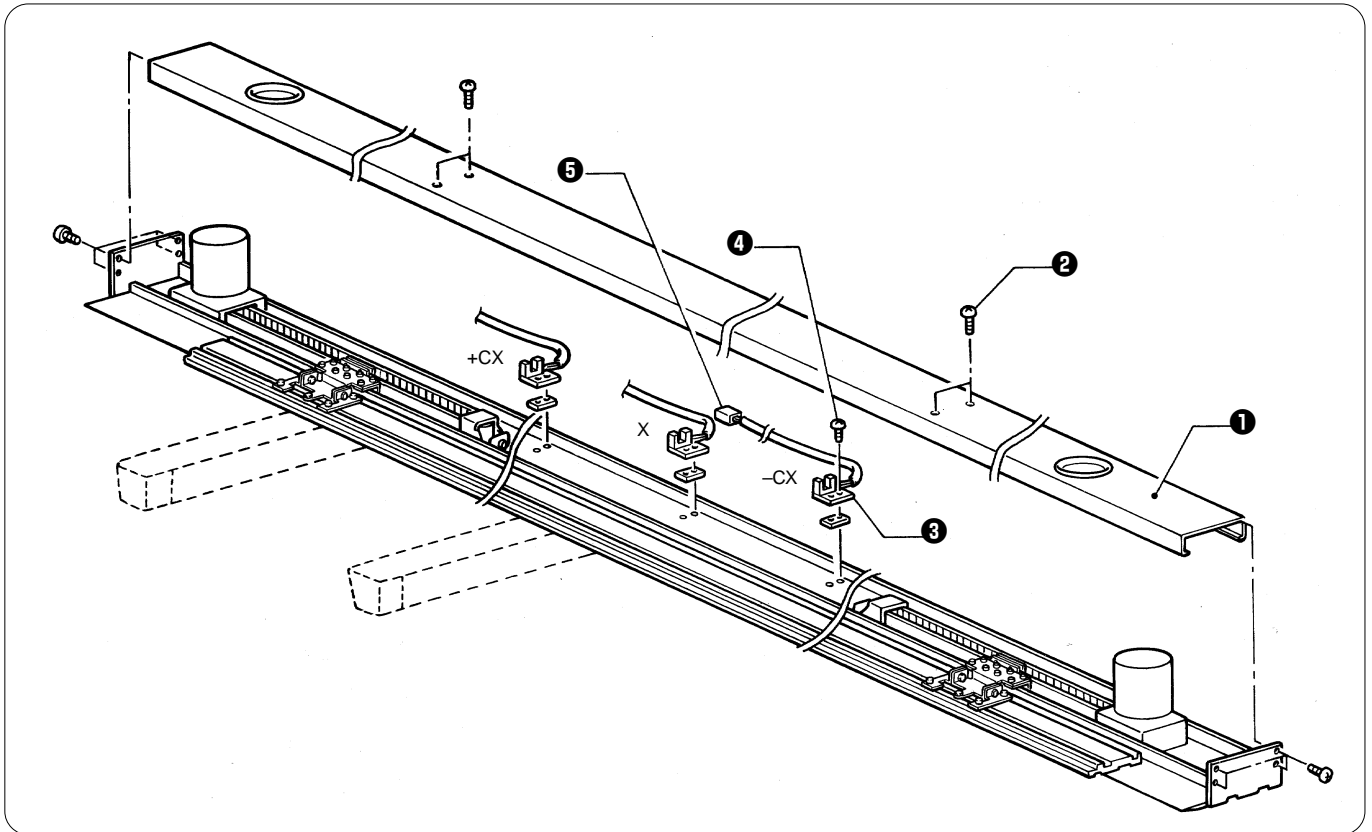

1. Remove the 12 screws **2**, and the X-feed cover **1**.
  2. Remove the two screws **4**, and the connector **5**, and replace the X-feed sensor PCB **3** with a new one.
- Reverse the above procedure for re-assembly.

### Notes:

- When removing and reattaching connectors, do not pull on the cables; hold the connectors.
- Do not forget to attach the spacer to the bottom of the PCB.
- There are three kinds of X-feed sensor PCBs **3**: +CX, X, and -CX. Do not put them in other than their specified positions.

## 11. Replacing the retracting bed sensor PCB

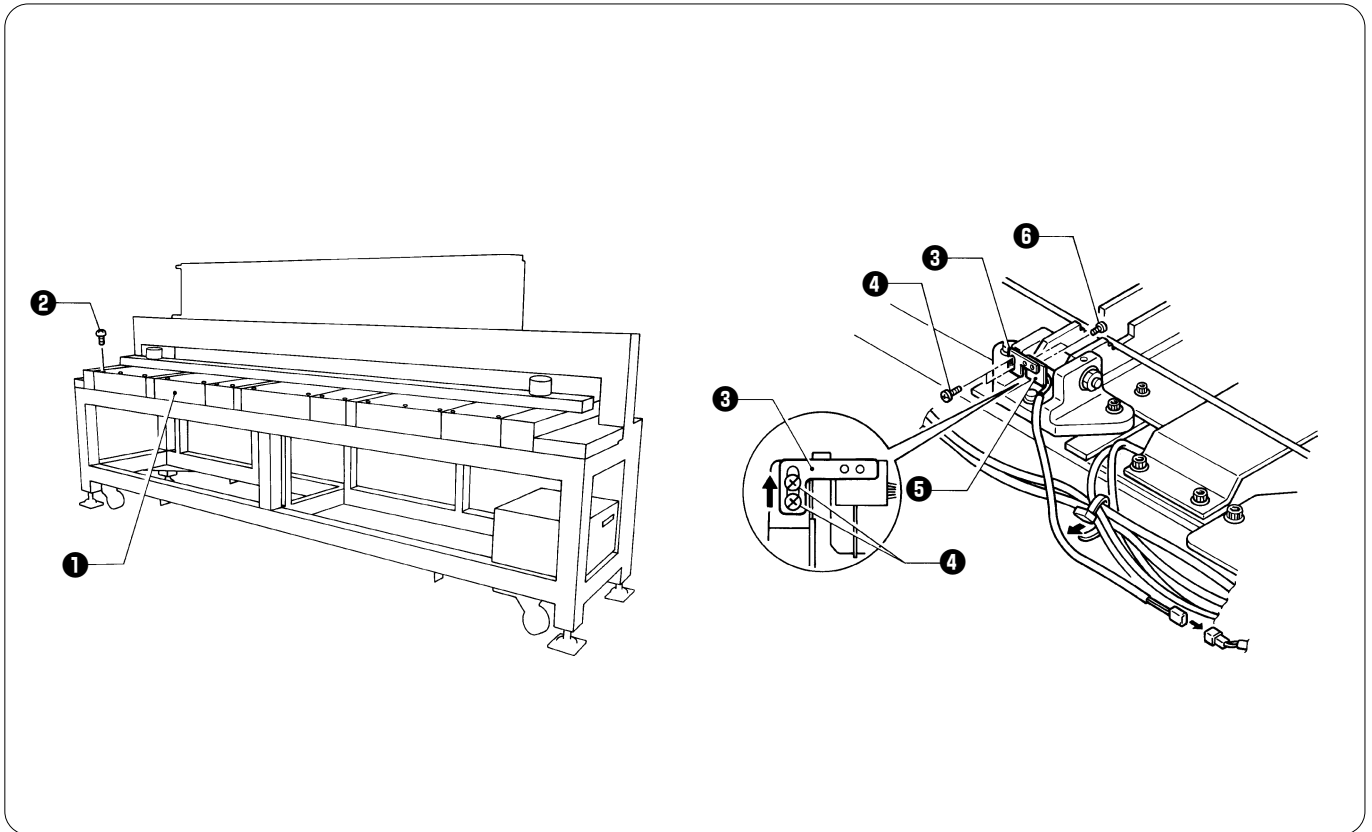

1. Remove the eight screws **2**, and then the table cover **1** by slowly pulling it upward.
2. Remove the two screws **4**, and the retracting bed sensor PCB **5** along with the dog plate **3**.
3. Remove the connector from the retracting bed sensor PCB **5**.
4. Remove the two screws **6**, and replace the retracting bed sensor PCB **5** with a new one.
5. After replacing the retracting bed sensor PCB, adjust the position of the bed retracting sensor.  
Attach the dog plate **3** to the highest position.  
The machine will start to recognize the head which is stopped via the dog plate **3** after the bed is inclined about **10** degrees.

**Notes:**

When retracting the beds and operating the machine, the beds should make complete contact with the machine leg.  
When removing and reattaching connectors, do not pull on the cables; hold the connectors.

## 12. Replacing the thread trimming sensor PCB

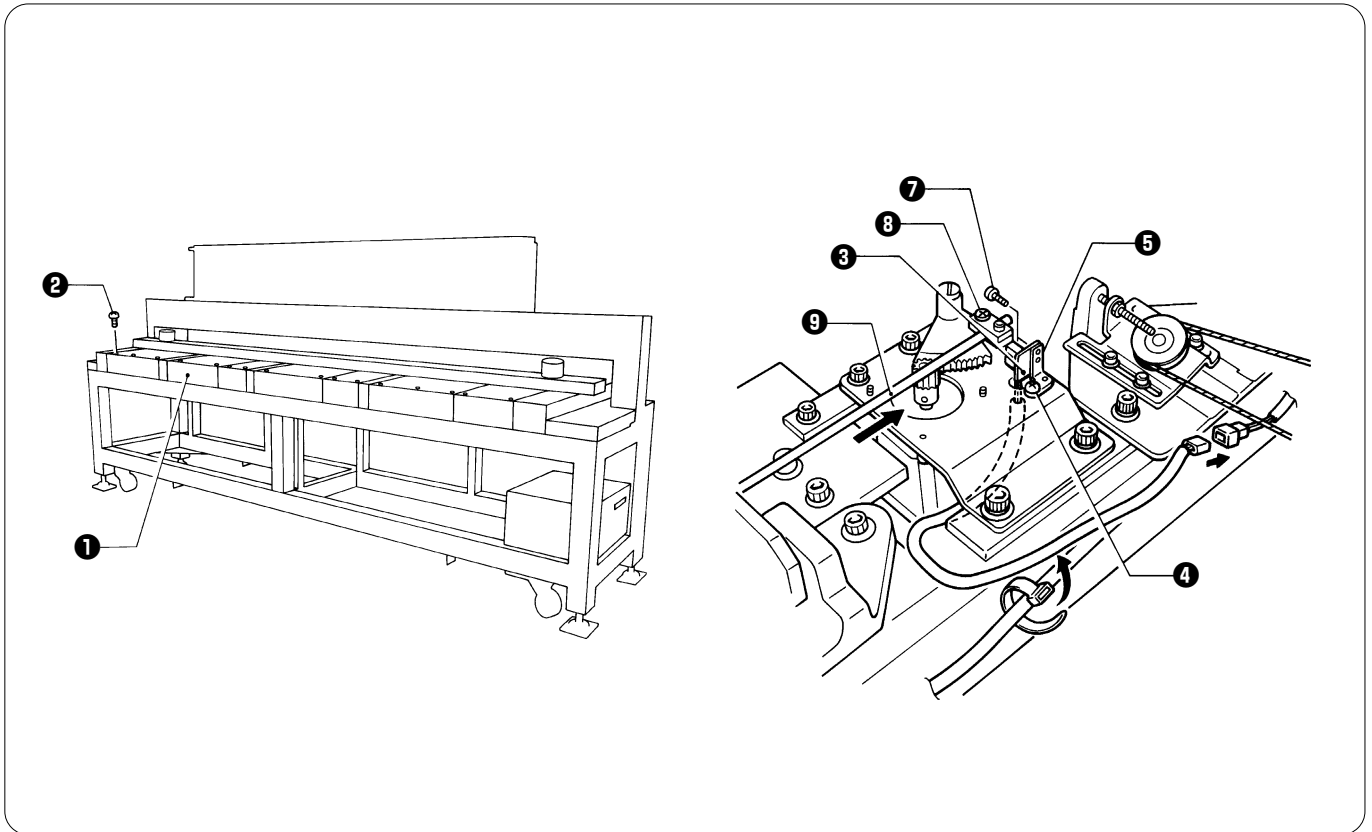

1. Remove the five screws ②. Remove the table cover ① by slowly pulling it upward.
2. Remove the screw ④, TR dog plate ③, and thread trimming sensor PCB ⑤.
3. Remove the two screws ⑦, and replace the thread trimming sensor PCB ⑤ with a new one.  
Reverse the above procedure for re-assembly.
4. After replacing the thread trimming sensor PCB, loosen the screw ⑧, and turn on the power.
5. Move the connecting rod ⑨ all the way in the direction of the arrow, and tighten the screw ⑧.

### Notes:

When removing and reattaching connectors, do not pull on the cables; hold the connectors.

# 13. Replacing the cooling fans

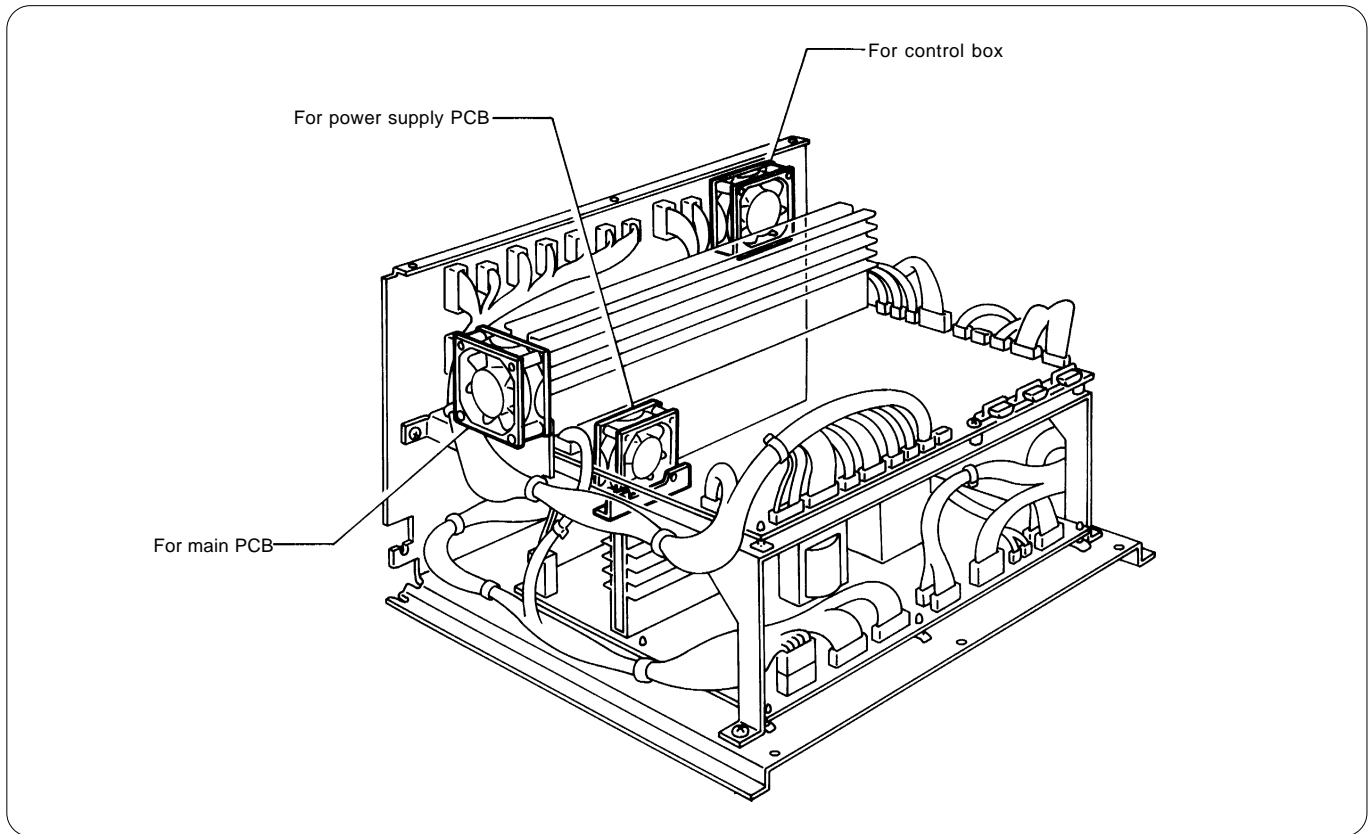

Note:  
As to the control box, refer to "2-2. Removing and attaching the control box cover."

## 13-1. Replacing the control box fan

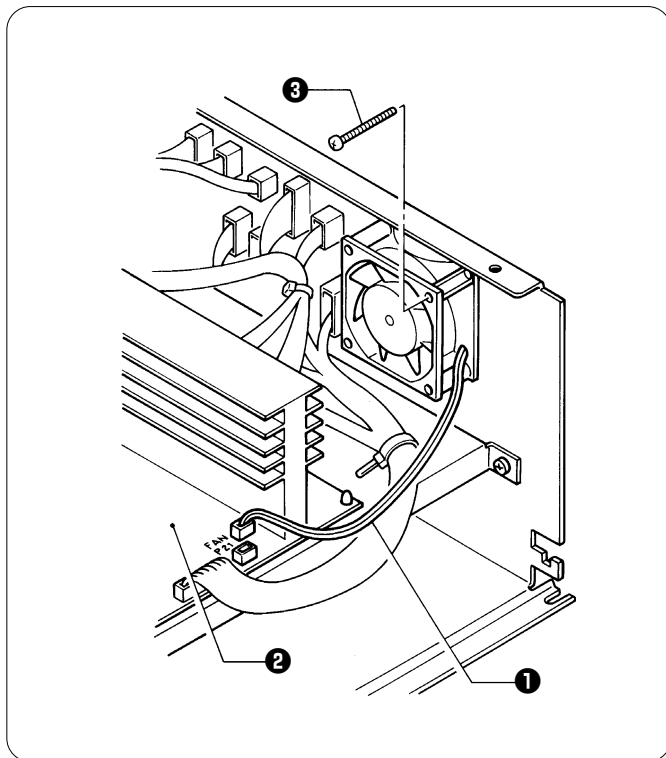

1. Remove the connector ❶ of the control box fan from P12 (FAN) on the main PCB ❷.
2. Remove the four screws ❸, and replace the control box fan with a new one.  
Reverse the above procedure for re-assembly.

## 13-2. Replacing the main PCB fan

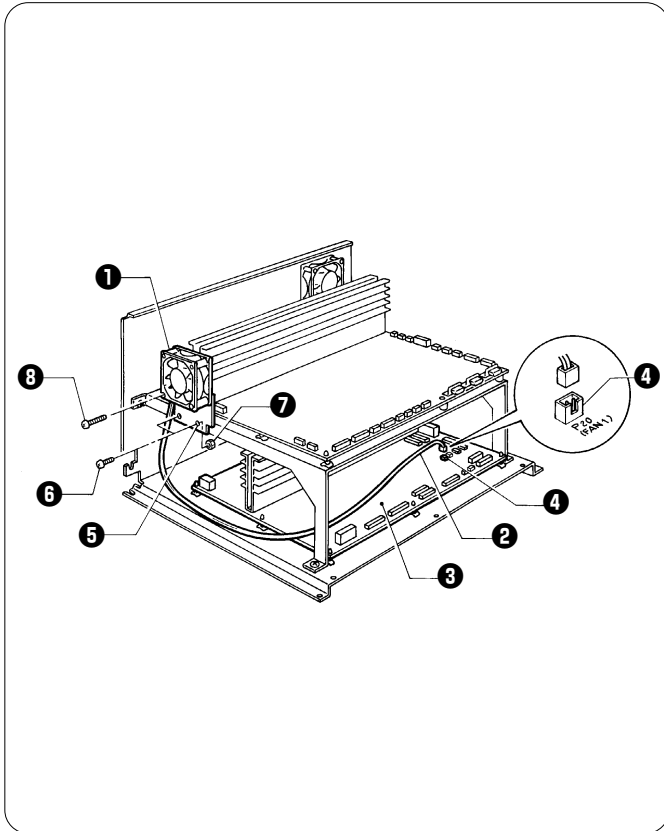

1. Remove the connector ② of the main PCB fan ① from P20 (FAN1) ④ on the power supply PCB ③.
2. Remove the two screws ⑥ and the nut ⑦ to separate the main PCB fan ① and the fan setting plate ⑤ together.
3. Remove the two screws ⑧, and replace the main PCB fan ① with a new one.  
Reverse the above procedure for re-assembly.

## 13-3. Replacing the power supply PCB fan

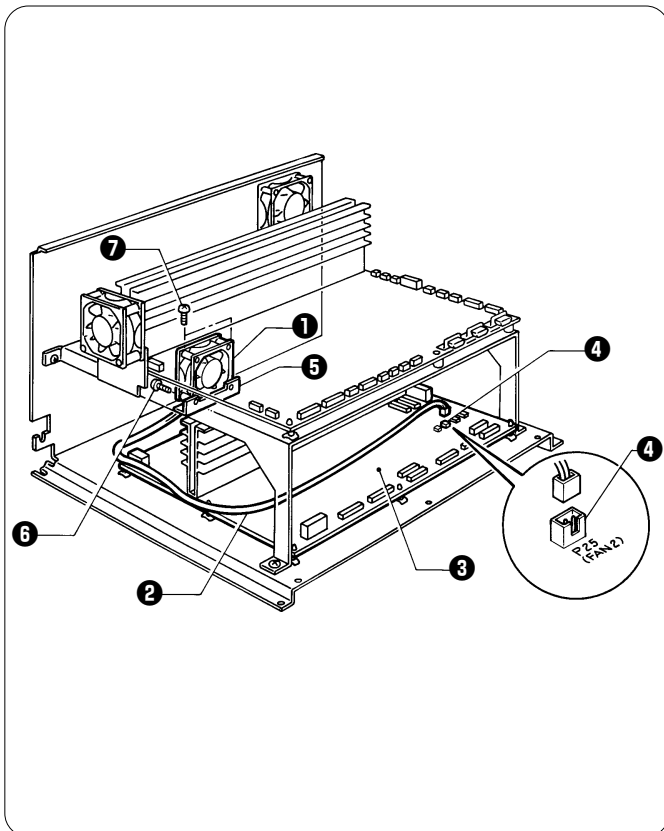

1. Remove the connector ② of the power supply PCB fan ① from P25 (FAN2) ④ on the power supply PCB ③.
2. Remove the two screws ⑥ from the rear of the control box, and separate the power supply PCB fan ① and the fan setting plate ⑤ together.
3. Remove the two screws ⑦, and replace the power supply PCB fan ① with a new one.  
Reverse the above procedure for re-assembly.

# 14. Fuses

## 14-1. Fuse positions

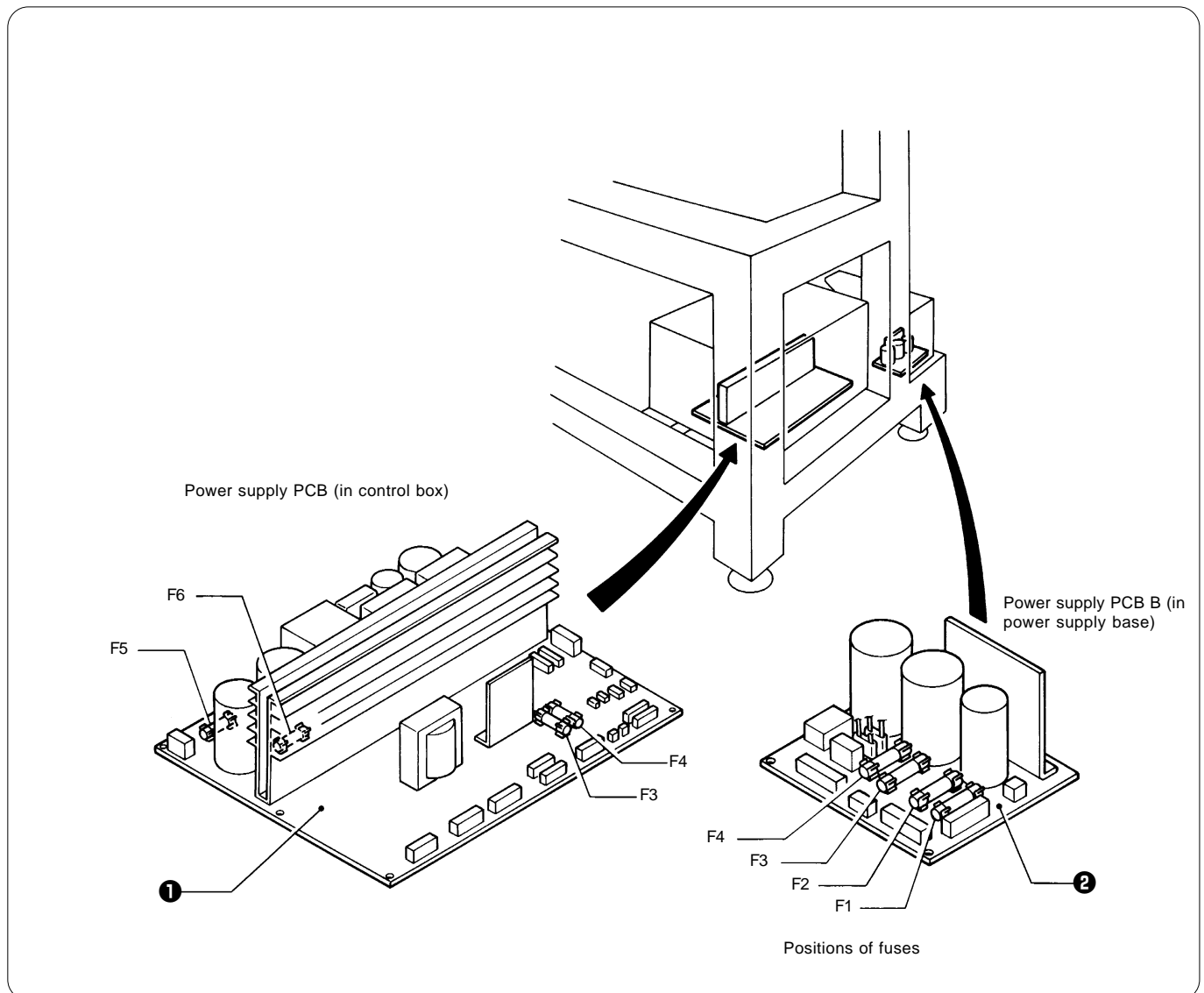

**Notes:**

- As to the control box, refer to "2-2. Removing and attaching the control box cover."
- As to the leg cover and the power base cover, refer to "3-1. Removing and attaching the leg cover and the power supply base cover."

1. Fuses F3-F6 are mounted on the power supply PCB in the control box.
2. Fuses F1-F4 are mounted on power supply PCB B in the power supply base.

**Notes:**

- Before replacing a fuse, .be sure to turn off the power and wait for at least 5 minutes after the power plug has been removed from the socket.
- Be sure to use only fuses of authorized types and capacities.
- During replacement, tightly install each fuse into its socket.

## 14-2. Fuse type and capacity

Fuses on the power supply PCB in the control box

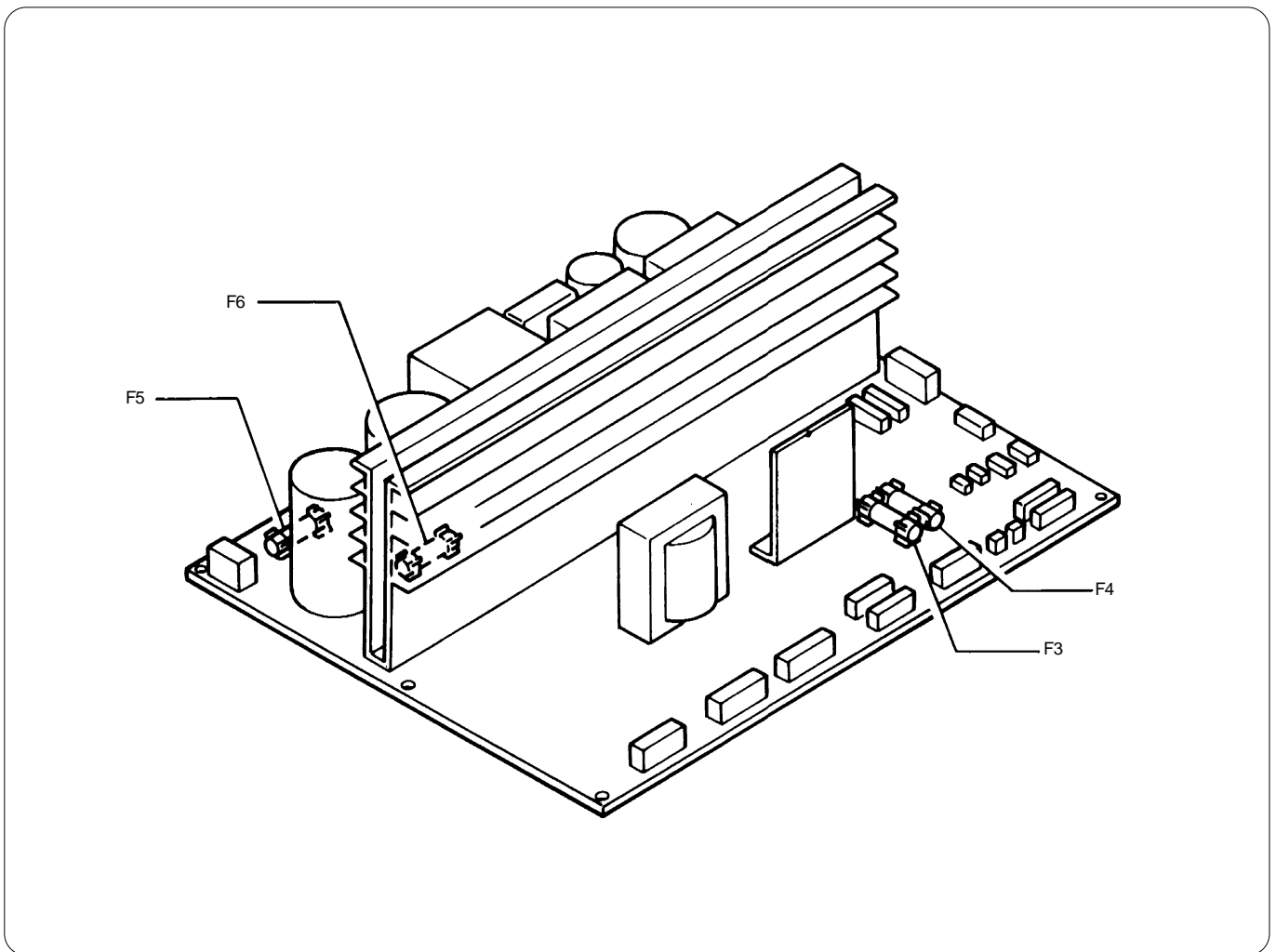

Note:  
Fuses F1 and F2 are not used.

No	Address	Fuse type and capacity	Part code	Remarks
1	F3	Glass tube fuse 0.2A/125V	S43643000	For RS232
2	F4	Glass tube fuse 1A/125V	S43642000	For RS232 and lower shaft fan
3	F5	Glass tube fuse 8A/250V (instantaneous fuse)	S43641000	For driving shaft motor
4	F6	Glass tube fuse 8A/250V (instantaneous fuse)	S43641000	+55V switching power supply (X and Y motors)



Fuses on power supply PCB B in the power supply base

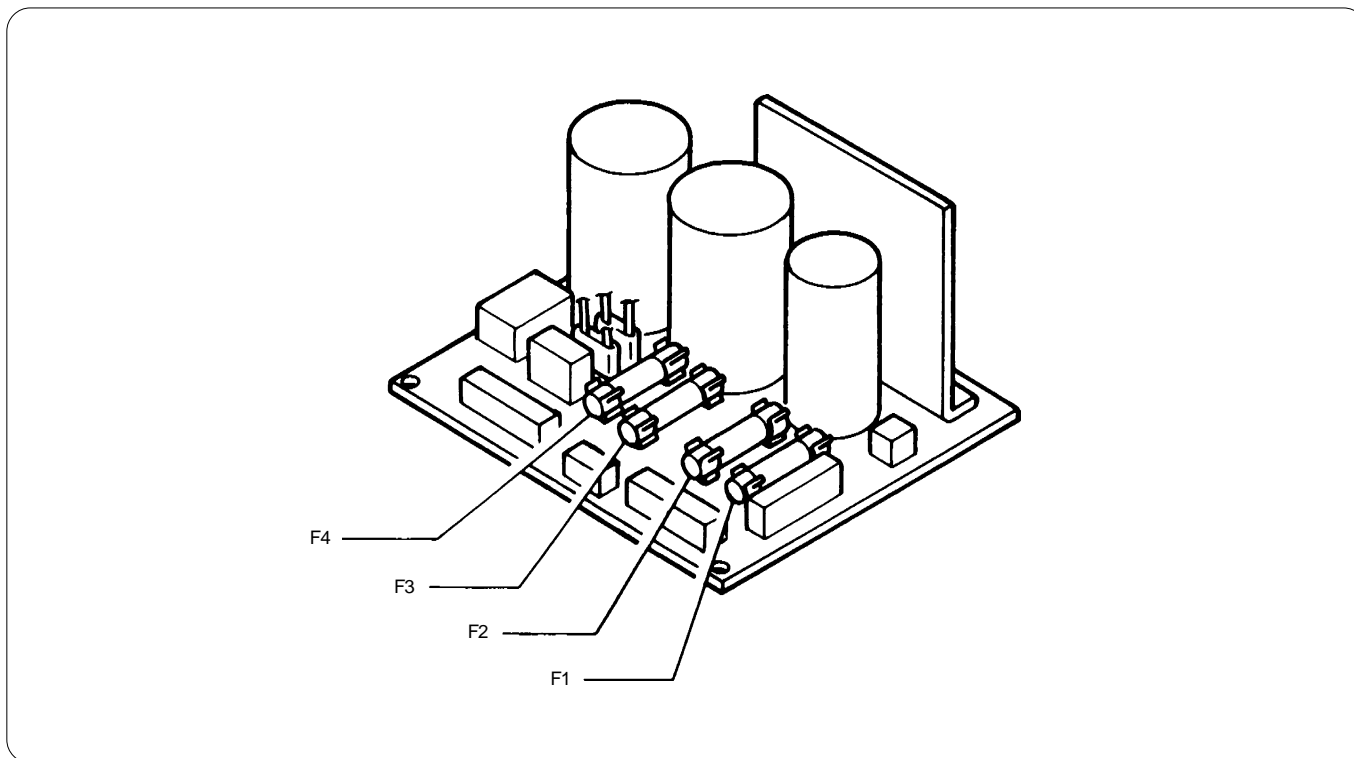

No.	Address	Fuse type and capacity	Part code	Remarks
5	F1	Glass tube fuse 8A/250V	620833080	For AC power supply This supplies AC power supply to the control box.
6	F2	Glass tube fuse 8A/250V	620833080	
7	F3	Glass tube fuse 8A/250V	620833080	+24 V power supply (Color change motor, presser foot motor, main shaft brake solenoid, fan in control box, lower shaft, thread trimming control power supply)
8	F4	Glass tube fuse 15A/250V	S02887000	+50V power supply (Jump solenoid, wiper solenoid)

## 14-3. Replacing the fuses

The following shows problems when a fuse has blown. (For reference when replacing fuses)

### Fuses on the power supply PCB in the control box

No.	Fuses on the power supply PCB in the control box Problem
F3	No problem under the current specifications
F4	All lower shaft fans do not turn.
F5	The main shaft motor does not run. Error E-A1 occurs.
F6	X axis, Y axis, and lower shaft do not move at all. Thread trimmer does not operate. Error E-09 or B9 occurs.

### Fuses on power supply PCB B in the power supply base

No.	Fuses on power supply PCB B in the power supply base Problem
F1	Machine does not work even when power is turned on. POWER LED is not lit.
F2	The same above
F3	Color change can not be done. Thread trimmer and lower shaft do not work. Error E-07, B9, or C4 occurs.
F4	Wiper and jump bracket do not work.

## 15. Handling the circuit protector of the bobbin winder (optional)

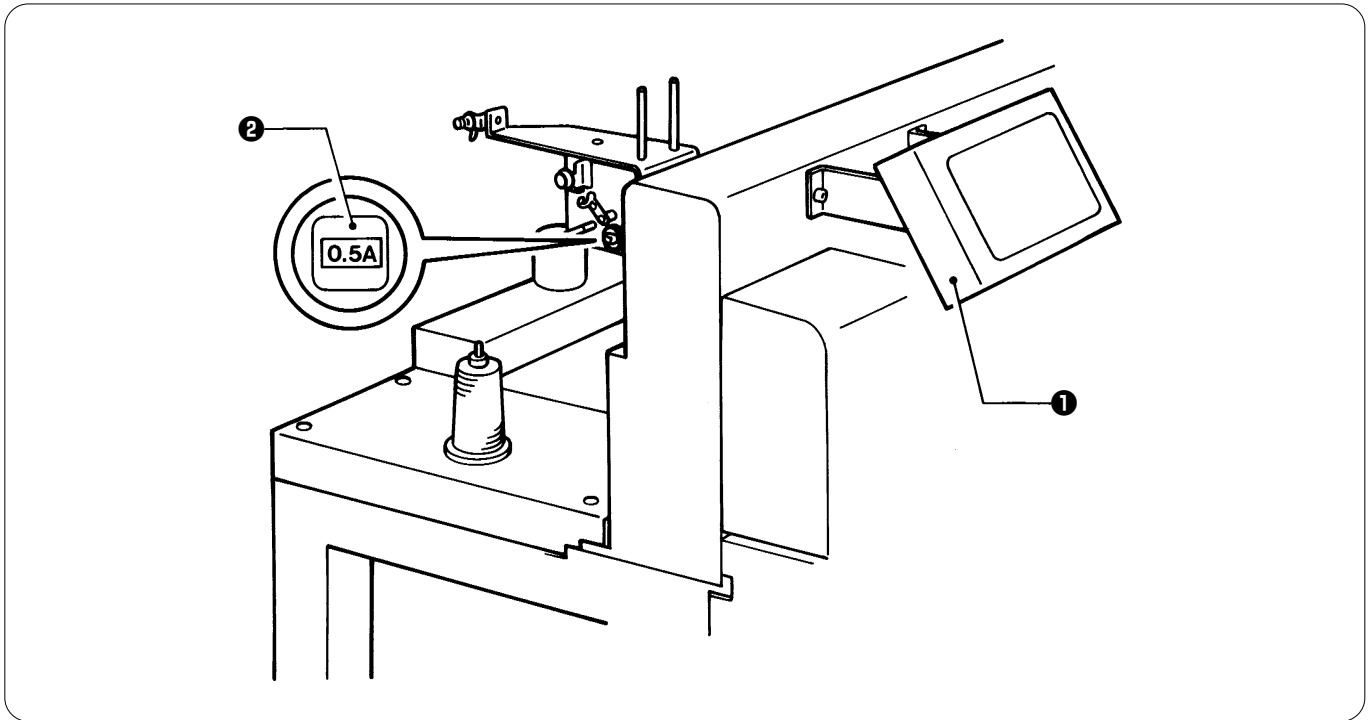

The bobbin winder is installed at the rear of the bridge which is attached to the operation panel **1** (on the left head when viewed from the operator side).

Note:

After the circuit protector **2** has tripped, the bobbin winder motor will not rotate. Let the protector **2** cool for a while before resetting it or it may trip again soon.

## 16. P-ROM position

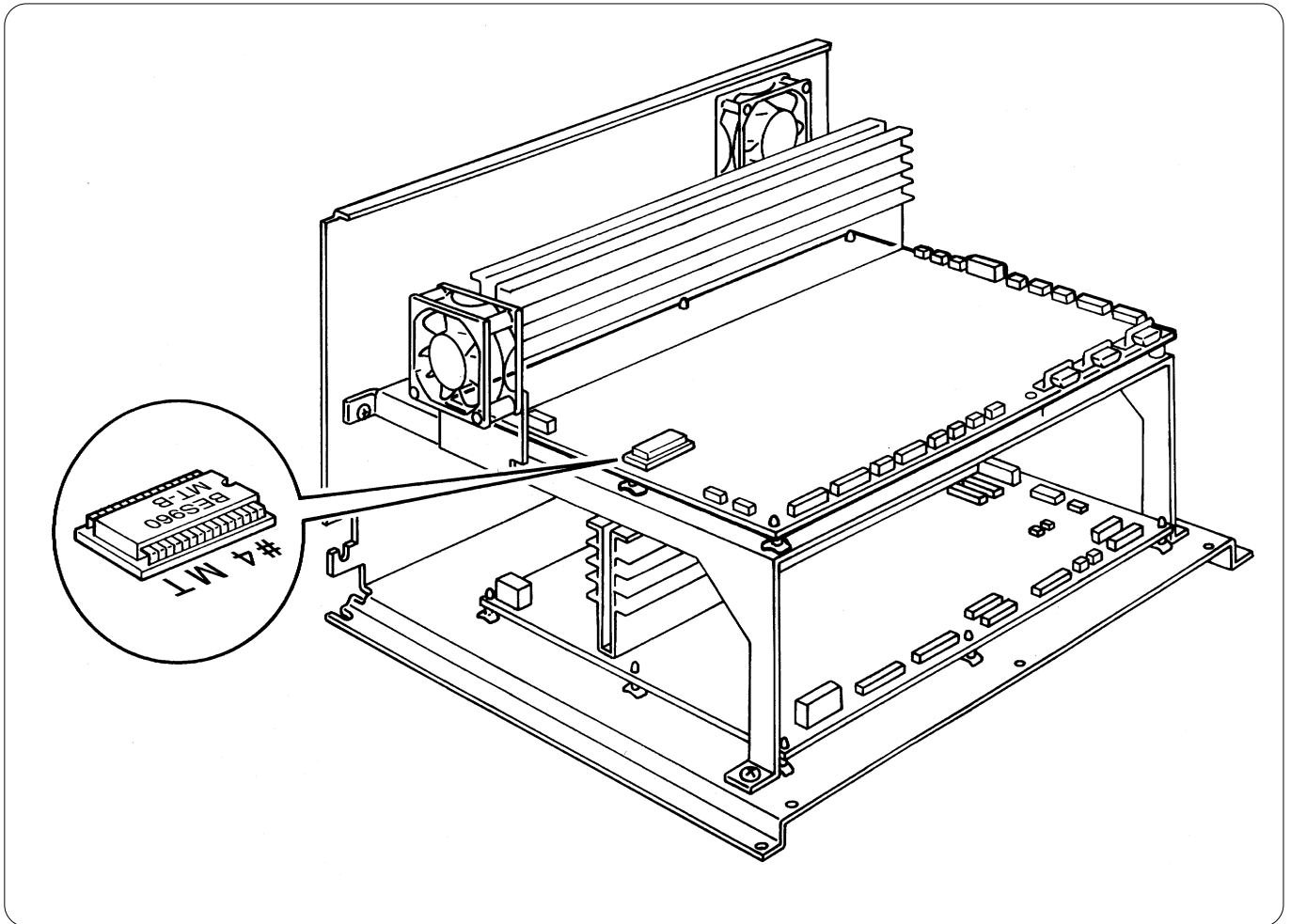

Be sure to turn off the power before replacement  
notes:

- Use care when handling the PROMs. Make sure the pins are properly inserted in the sockets.
- Do not apply excessive force when mounting the PROM on the circuit board.
- Confirm that the PROMs are in the correct position and direction.
- Use of the special PROM removal tool is recommended when removing the PROM. If a screwdriver must be used, be careful not to damage the PROM socket and the circuit board. Carefully lift the PROM little by little from both sides. See the figure.

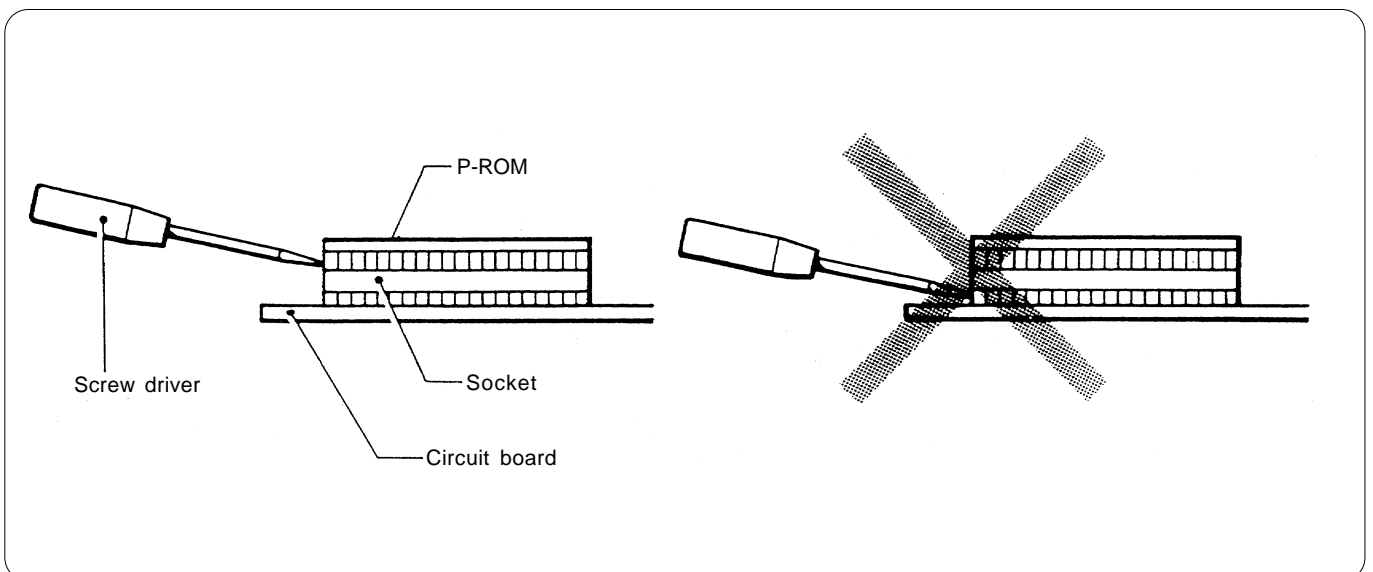

# 17. Connectors

## 17-1. Main PCB connectors

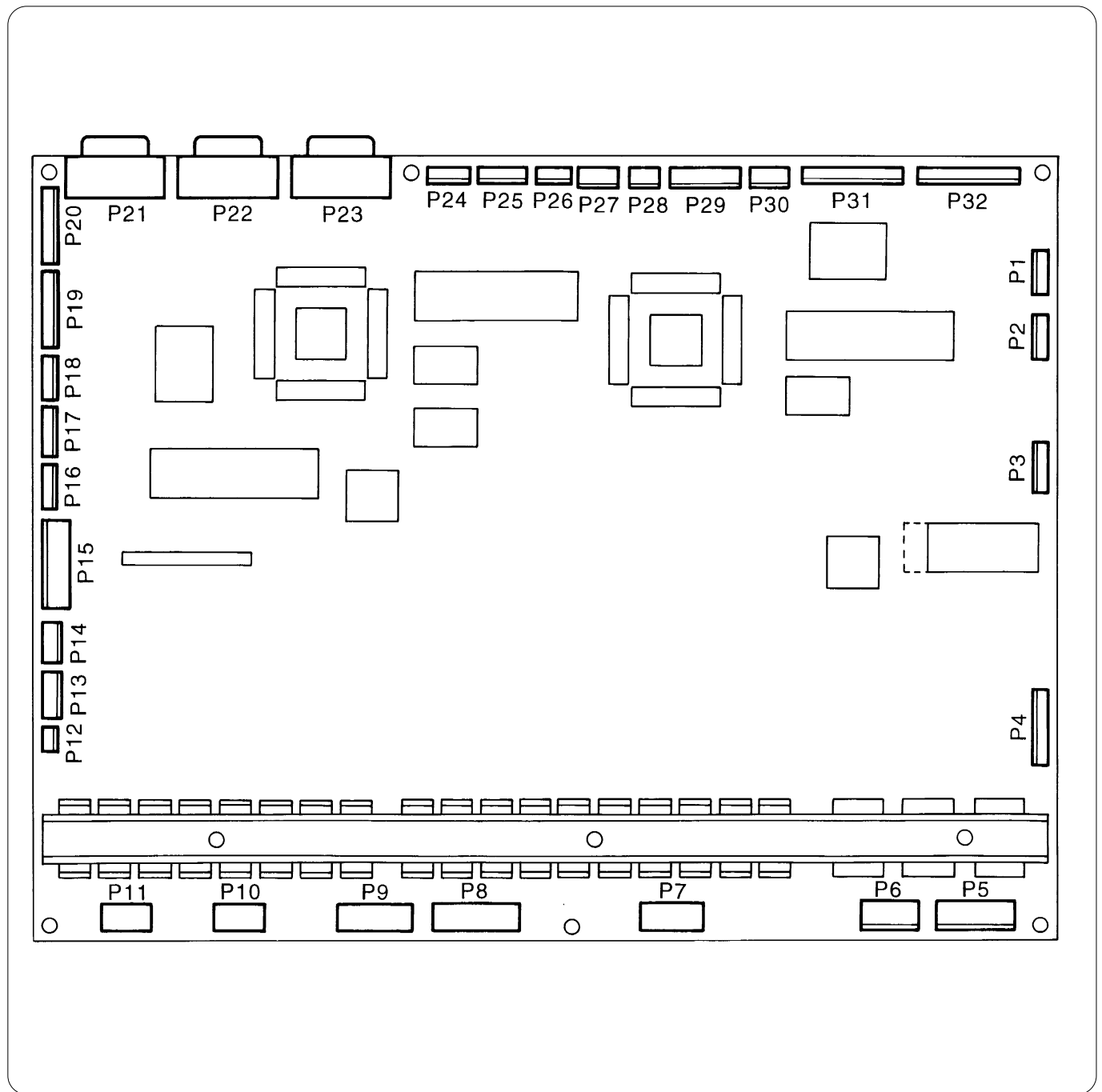

## Connectors on the main PCB

Connector No.	Connecting point	Drive signal	Symptoms resulting from improper connection or breakage
P1	Main PCB - Power supply PCB in control box (P27)	Main shaft brake Expansion signal	Main shaft brake remains locked .
P2	Main PCB - Bed retracting sensor	Bed retracting sensor	Red lamp is not lit even when HEAD switch is on (thread breakage sensor is activated). Heads No. 2, 4, and 6 are suspended. Presser foot does not retract.
P3	Unused	For testing	
P4	Main PCB - Power supply PCB in control box (P12)	Inverter control power supply	Error E-A1 appears when embroidering is started.
P5	Main PCB - Main shaft motor	Main shaft motor output	Error E-A1 appears when embroidering is started.
P6	Main PCB - Power supply PCB in control box (P19)	Main shaft motor power supply	Error E-A1 appears when embroidering is started.
P7	Main PCB - Y motor	Y motor output	Error E-14 appears when power is turned on.
P8	Main PCB - X motor	X motor output	Error E-18 appears when power is turned on.
P9	Main PCB - Power supply PCB in control box (P3)	+55 V power supply (X and Y motors, and thread trimmer motor)	Error E-B9 appears when power is turned on.
P10	Main PCB - Thread trimmer motor 1	Thread trimmer motor 1 output	Error E-B9 appears when power is turned on.
P11	Main PCB - Thread trimmer motor 2	Thread trimmer motor 2 output	Error E-B9 appears when power is turned on.
P12	Main PCB - Cooling fan in control box	Cooling fan power supply Cooling fan stop signal	Error E-E3 appears when power is turned on.
P13	Main PCB - BC PCB	Lower shaft drive signal	Error E-B2 appears when power is turned on.
P14	Main PCB - INDEX motor	INDEX motor output	Error E-07 appears when needle bar is changed for color change.

## Connectors on the main PCB

Connector No.	Connecting point	Drive signal	Symptoms resulting from improper connection or breakage
P15	Main PCB - Power supply PCB in control box (P17)	Main PCB power supply	Nothing works. POWER LED is not lit.
P16	Main PCB - Power supply PCB in control box (P10)	Power supply control	Error E-D2 appears when power is turned on.
P17	Unused	For lower shaft testing	
P18	Main PCB - Thread trimming sensor	Thread trimming sensor	Error E-B9 appears when power is turned on.
P19	Main PCB - BC PCB 1 (p10) - BC PCB 2 (P10)	+5 V power supply Control signal	Error E-B2 appears when power is turned on.
P20	Main PCB - BC PCB 3 (P10)	+5 V power supply Control signal	Error E-B2 appears when power is turned on.
P21	Main PCB -	For communication cable (SBUS)	For a cable on PC side, window of machine is not open even when controller is activated.
P22	Main PCB -	For communication cable (SBUS)	
P23	This is not used in this specification	For communication cable (RS232C)	
P24	Not mounted	For testing	
P25	Not mounted	For testing	
P26	Main PCB - Needle position detection sensor - rotary encoder	Main shaft encoder Stop position sensor	Error E-A1 appears when embroidering is started..
P27 P28	Main PCB - START-EM switch	Start switch Emergency stop switch	P27: Embroidering is not started even when start switch has pressed. P28: STOP is indicated when power is turned on.
P29	Main PCB - Operation panel	+5V Communication line Stop switch	When power is turned on, the machine will work with its default settings but nothing will appear on the panel. POWER LED will not be lit.
P30	Main PCB - Head PCB (P4)	Communication line	Error E-07 appears when power is turned on.

## Connectors on the main PCB

Connector No.	Connecting point	Drive signal	Symptoms resulting from improper connection or breakage
P31	Main PCB - Y area sensor	Y home position sensor	Error E-14 appears when power is turned on.
P32	Main PCB - X area sensor	X home position sensor CAP limit sensor	Error E-09 appears when power is turned on.



## Cable signals

Main PCB		Power supply PCB in control box	
<b>P15</b>	1 +24V 2 GND 3 +12V 4 GND 5 -12V 6 +5V 7 GND	<b>P17</b>	1 +24V 2 SOV 3 +12V 4 SOV 5 -12V 6 +5V 7 SOV
<b>P9</b>	1 +Vm 2 +Vm 3 4 5 GND 6 GND	<b>P3</b>	1 +55V 2 +55V 3 4 5 POV 6 POV
<b>P6</b>	1 GND 2 DC300V	<b>P19</b>	1 ±0V 2 DC300V
<b>P4</b>	1 VA 2 GA 3 4 VB 5 GB 6 7 VC 8 GC 9 10 VN 11 GN	<b>P12</b>	1 E20V 2 E0V 3 4 F20V 5 F0V 6 7 G20V 8 G0V 9 10 H20V 11 H0V
<b>P16</b>	1 ZCROSS 2 DCMON 3 GND 4 IERR 5 FSTOP 6 P-OFF	<b>P10</b>	1 ZCROSS 2 DCMON 3 GND 4 IERR 5 FSTOP 6 P-OFF

## Cable signals

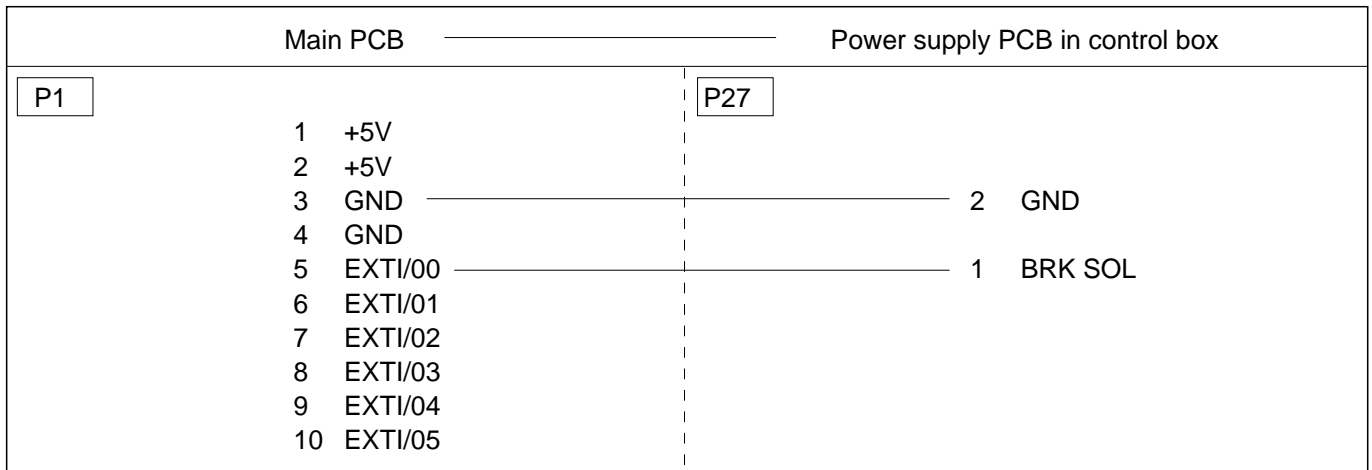

Cable signals

Main PCB		PANEL BACK	LOCAL	
<b>P32</b>		32	X area sensor	
1	+5V	1	Vk	1 AN
2	XINDEX	2	XINDEX	2 C
3	GND			
4	F 5V			
5	OVTR-X			
6	GND			
7	F 5V			
8	OVTR+X			
9	GND			
10	C 5V	3	Vk	1 AN
11	COVTR-X	4	COVTR-X	2 C
12	GND			
13	C 5V	5	Vk	1 AN
14	COVTR+X	6	COVTR+X	2 C
15	GND	7	GND	3 COMX,COM-CX,COM+CX
		8		
<b>P31</b>		31	Y area sensor	
1	+5V	1	Vk	1 AN
2	YINDEX	2	YINDEX	2 C
3	GND	3	GND	3 COM
4	F 5V	4	Vk	
5	OVTR-Y	5	OVTR-Y	
6	GND	6	GND	
7	F5V	7	Vk	
8	OVTR Y	8	OVTR+Y	
9	GND	9	GND	
10	C 5V	10	Vk	
11	COVTR-Y	11	COVTR-Y	
12	GND	12	GND	
13	C 5V	13	Vk	
14	COVTR+Y	14	COVTR+Y	
15	GND	15	GND	
		16		
<b>P26</b>		26	Rotary encoder	
1	A	1	A	1 A
2	B	2	B	6 B
3	Z	3	Z	3 Z
4	+5V	4	+5V	4 +5V
5	GND	5	GND	5 GND
6				
7	+5V	6	Vk	1 AN
8	NLUP	7	NLUP	2 C
9	GND	8	GND	3 COM
				Needle position detection sensor

## Cable signals

Main PCB		PANEL BACK		LOCAL	
<b>P14</b>		<b>C</b>		<b>INDEX motor (color change motor)</b>	
1	OUT1	1	OUT1	1	A Orange
2	OUT2	2	OUT2	2	$\bar{A}$ Blue
3	OUT3	3	OUT3	3	B Red
4	OUT4	4	OUT4	4	$\bar{B}$ Yellow
Power supply PCB in control box		<b>6</b>		<b>Bobbin winder motor</b>	
<b>P6</b>				1.	+24V White
1	+24V	1	+24V	2.	GND Black
2		2	GND		
3	GND				
Main PCB		<b>M</b>		<b>Machine motor</b>	
<b>P5</b>				1	U Red
1	U	1	U	2	V White
2	V	2	V	3	W Black
3	W	3	W	4	E Yellow/Green
		4	E		
<b>P8</b>		<b>X</b>		<b>X motor</b>	
1	A	1	A	1	A Black
2	B	2	B	2	B Red
3	C	3	C	3	C Orange
4	D	4	D	4	D Yellow
5	E	5	E	5	E Blue
6	CONNECT	6	CONNECT	6	CNT
7	GND	7	GND	7	
		8		8	
<b>P7</b>		<b>Y</b>		<b>Y motor</b>	
1	A	1	A	1	A Black
2	B	2	B	2	B Red
3	C	3	C	3	C Orange
4	D	4	D	4	D Yellow
5	E	5	E	5	E Blue
		6		6	
Main PCB		PANEL BACK		Local	
<b>P30</b>	30	<b>P4</b>	<b>P6</b>	<b>P4</b>	<b>P6</b>
1	DATA+	1	SDT	1	SDT
2	DATA-	2	$\overline{\text{SDT}}$	2	$\overline{\text{SDT}}$
3	CLK+	3	SCK	3	SCK
4	CLK-	4	$\overline{\text{SCK}}$	4	$\overline{\text{SCK}}$
					$\overline{\text{SCK}}$

Cable signals

Main PCB		PANEL BACK	LOCAL		
<b>P27</b>		27	START-EM switch		
1	<u>START</u>	1	<u>START</u>	1	<u>START</u>
2	<u>GND</u>	2	<u>GND</u>	2	<u>GND</u>
3	<u>STOP</u>	3	<u>STOP</u>		
4	<u>GND</u>	4	<u>GND</u>		
<b>P28</b>					
1	N. C.	5	N. C.	3	N. C.
2	N. O	6	N. O	4	N. O
3	COM	7	COM	5	GND
<b>P29</b>		29	Operation panel		
1	DATA+	1	SDT		
2	DATA-	2	<u>SDT</u>		
3	CLK+	3	SCK		
4	CLK-	4	<u>SCK</u>		
5	+5V	5	+5V		
6	<u>GND</u>	6	<u>GND</u>		
7	<u>STOP</u>	7	<u>STOP</u>		
8	<u>GND</u>	8	<u>GND</u>		
		9			
		10	FG		
<b>P2</b>		2	Bed retracting sensor		
1	Vk	1	Vk	1	AN
2	BED1	2	BED1	2	C
3	<u>GND</u>	3	<u>GND</u>	3	COM
4	Vk	4	Vk	1	AN
5	BED2	5	BED2	2	C
6	<u>GND</u>	6	<u>GND</u>	3	COM
7	Vk	7	Vk	1	AN
8	BED3	8	BED3	2	C
9	<u>GND</u>	9	<u>GND</u>	3	COM
10	Vk	10			
11	BED4	11			
12	<u>GND</u>	12			
Main PCB	PANEL BACK	BC PCB(No2,3)		BC PCB(No1)	
<b>P13</b>	13	<b>P8</b>	<b>P9</b>	<b>P8</b>	<b>P9</b>
1 +24V	1 +24	1 +24V	1 +24V	1 +24V	1 +24
2 BCLK	2 BCLK	2 CLK0	2 CLK1	2 CLK0	2 CLK1
3 BDIR	3 BDIR	3 DIR0	3 DIR1	3 DIR0	3 DIR1
4 BSAV	4 BSAV	4 SAY0	4 SAV1	4 SAV0	4 SAV1
5 BBRK	5 BBRK	5 BRK0	5 BRK1	5 BRK0	5 BRK1
	6	6 GND		6 GND	

## Cable signals

Main PCB	Panel back	BC PCB
<b>P19</b>	<b>19A</b>	<b>P10</b>
1 +5V	1 +5V	1 +5V
2 GND	2 GND	2 GND
3 BSEL	3 BSEL0	3 LENB
4 BENCA	4 BENCA0	4 LOUTA
5 BENC B	5 BENC B0	5 LOU T B
6 +5V	6 +5V	6 +5V
7 GND	7 GND	7 GND
8 BSEL	8 BSEL1	8 RENB
9 BENCA	9 BENCA1	9 ROUTA
10 BENC B	10 BENC B1	10 ROUTB
11 EMGX	11 EMGX	11 EMG
12 +5V	1 +5V	1 +5V
13 GND	<b>19B</b> 2 GND	<b>P10</b> 2 GND
14 BSEL	3 BSEL2	3 LENB
15 BENCA	4 BENCA2	4 LOUTA
16 BENC B	5 BENC B2	5 LOU T B
17 +5V	6 +5V	6 +5V
18 GND	7 GND	7 GND
19 BSEL	8 BSEL3	8 RENB
20 BENCA	9 BENCA3	9 ROUTA
21 BENC B	10 BENC B3	10 ROUTB
22 EMGY	11 EMGY	11 EMG
<b>P20</b>	<b>A20</b>	<b>P10</b>
1 +5V	1 +5V	1 +5V
2 GND	2 GND	2 GND
3 BSEL	3 BSEL4	3 LENB
4 BENCA	4 BENCA4	4 LOUTA
5 BENC B	5 BENC B4	5 LOU T B
6 +5V	6 +5V	6 +5V
7 GND	7 GND	7 GND
8 BSEL	8 BSEL5	8 RENB
9 BENCA	9 BNCA5	9 ROUTA
10 BENC B	10 BENC B5	10 ROUTB
11 EMGX	11 EMGX	11 EMG
12 +5V		
13 GND		
14 BSEL		
15 BENCA		
16 BENC B		
17 +5V		
18 GND		
19 BSEL		
20 BENCA		
21 BENC B		
22 EMGY		

Cable signals

Main PCB		Panel back	
<b>P18</b>		18	Thread trimming sensor
1	Vk	1	Vk
2	TSENS1	2	TSENS1
3	GND	3	GND
4	Vk	4	Vk
5	TSENS2	5	TSENS2
6	GND	6	GND
7	Vk	7	
8	TSENS3	8	
9	GND	9	
10	Vk	10	
11	TSENS4	11	
12	GND	12	
<b>P10</b>		T	Thread trimming motor
1	A+	1	A Orange
2	A-	2	$\bar{A}$ Blue
3	B+	3	B Red
4	B-	4	$\bar{B}$ Yellow
<b>P11</b>			
1	A+	5	A Orange
2	A-	6	$\bar{A}$ Blue
3	B+	7	B Red
4	B-	8	$\bar{B}$ Yellow

## 17-2. Connectors in power supply PCB in the control box

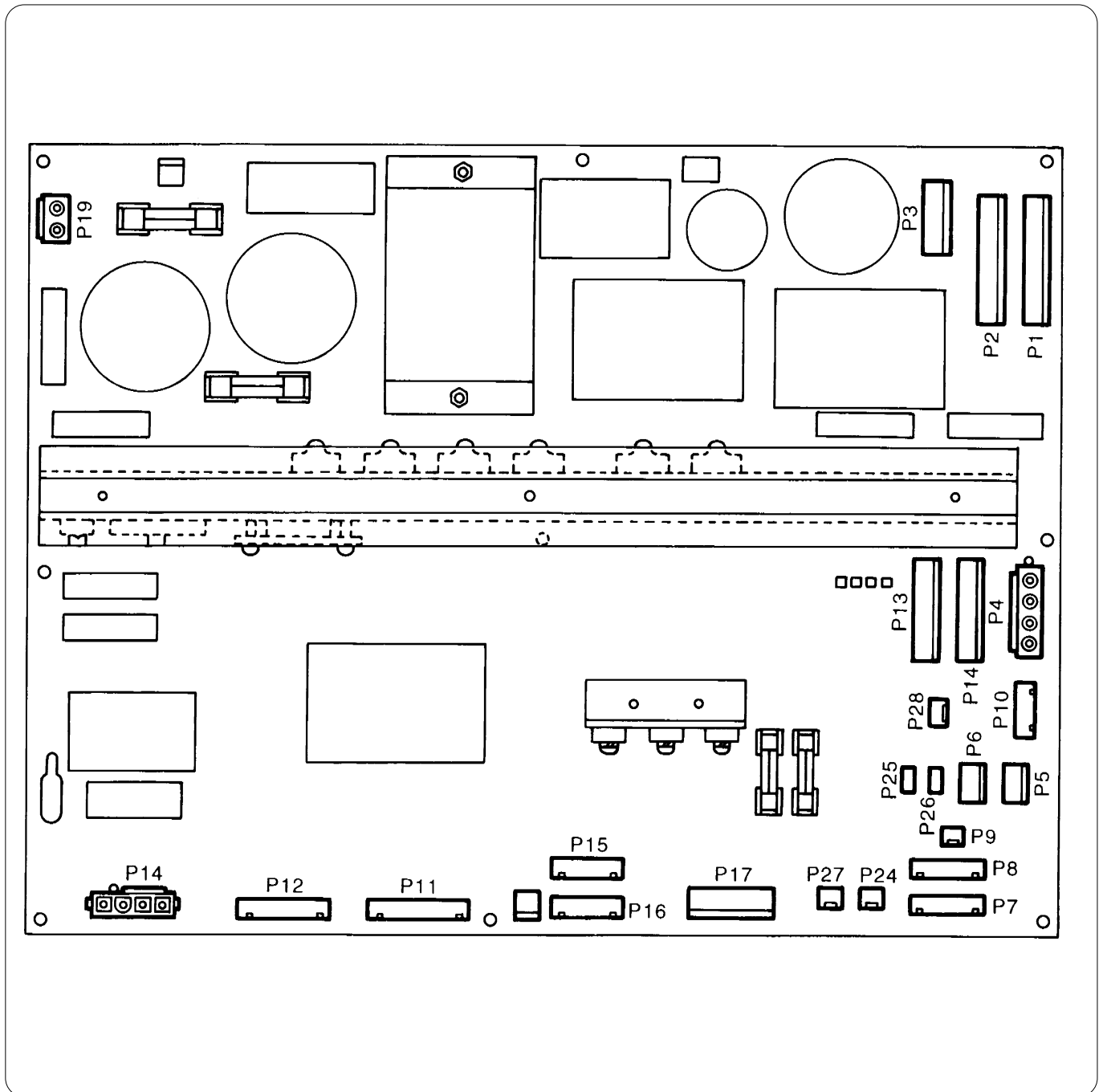



## Power supply PCB in control box

Connector No.	Connecting point	Drive signal	Symptoms resulting from improper connection or breakage
P1 P2	Power supply PCB - BC PCB	Power supply for +55V (lower shaft motor) and +12V (lower shaft fan)	Error E-B2 occurs when power is turned on.
P3	Power supply PCB - Main PCB (P9)	+55V power supply (X and Y motors, and thread trimming motor)	Error E-B9 occurs when power is turned on.
P4	Power supply PCB - Power supply PCB B in power supply base (P6)	+50V power supply	Needle bar does not jump. Wiper does not work.
P5	Power supply PCB - Power supply PCB B in power supply base (P1)	+24V power supply	Errors E-BA, E3, and D1 appear in sequence when power is turned on. Finally, error E-E3 appears.
P6	Power supply PCB in control box - Bobbin winder motor	+24V power supply	Bobbin can not be wound when bobbin winder motor is connected.
P7 P8	Power supply PCB - Head PCB	+24V power supply	Error E-C4 occurs when power is turned on.
P9	Unused	+24V power supply for expansion	/
P10	Power supply PCB - Main PCB (P16)	Power supply control	Error E-D2 occurs when power is turned on.
P11	Power supply PCB - Transformer 729VA	AC 14 V	Error E-A1 occurs when embroidering is started.
P12	Power supply PCB - Main PCB (P12)	Inverter control power supply	Error E-A1 occurs when embroidering is started.
P13 P14	Power supply PCB - Head PCB	+50V power supply	Needle bar does not jump. Wiper does not work.
P15 P16	Power supply PCB - Head PCB	+5V power supply	Error E-07 or E-C4 occurs when power is turned on.
P17	Power supply PCB - Main PCB	Main PCB power supply (+5V, ±12V, +24V)	Nothing works. POWER LED on panel is not lit.
P18	Power supply PCB - Power supply PCB B in power supply base (P2)	AC 200 V power supply	Nothing works. POWER LED on panel is not lit.
P19	Power supply PCB - Main PCB (P6)	Main shaft motor power supply (+300V)	Error E-A1 occurs when embroidering is started.
P20	Power supply PCB - Cooling fan 1	Cooling fan power supply Cooling fan stop signal	Error E-D1 occurs when power is turned on.

## Power supply PCB in control box

Connector No.	Connecting point	Drive signal	Symptoms resulting from improper connection or breakage
P25	Power supply PCB- Cooling fan 2	Cooling fan power supply Cooling fan stop signal	Error E-D1 occurs when power is turned on.
P26	Power supply PCB - Power supply PCB B in power supply base (P7)	Power cut detection input	Error E-BA occurs when power is turned on.
P27	Power supply PCB - Main PCB (P1)	Main shaft brake signal	Driving shaft stop position is apt to be improper. Error E-05 occurs.
P28	Power supply PCB - Main shaft brake solenoid	Main shaft brake solenoid output	The same above

## Cable signals

Power supply PCB in control box						PANEL BACK	Head PCB
P7	P8	P13	P14	P15	P16	1H	P12
1 DC24V		1 DC50V				1 Vmm	1 Vmm
5 GND		"				2 Vmm	2 Vmm
		5 GND				3 POV	3 POV
		"				4 POV	4 POV
				5 GND		5 +24V	5 +24V
				1 +5V		6 24VGND	6 24VGND
						7 GND	8 GND
						8 +5V	7 +5V
		2 DC50V				2H	P12
2 DC24V		"				1 Vmm	1 Vmm
6 GND		6 GND				2 Vmm	2 Vmm
		"				3 POV	3 POV
				6 GND		4 POV	4 POV
				2 +5V		5 +24V	5 + 24V
						6 24VGND	6 24VGND
						7 GND	8 GND
						8 +5V	7 +5V
		3 DC50V				3H	P12
3 DC24V		"				1 Vmm	1 Vmm
7 GND		7 GND				2 Vmm	2 Vmm
		"				3 POV	3 POV
				7 GND		4 POV	4 POV
				3 +5V		5 +24V	5 +24V
						6 24VGND	6 24VGND
						7 GND	8 GND
						8 +5V	7 +5V
		4 DC50V				4H	P12
4 DC24V		"				1 Vmm	1 Vmm
8 GND		8 GND				2 Vmm	2 Vmm
		"				3 POV	3 POV
				8 GND		4 POV	4 POV
				4 +5V		5 +24V	5 +24V
						6 24VGND	6 24VGND
						7 GND	8 GND
						8 +5V	7 +5V
			1 DC50V			5H	P12
			"			1 Vmm	1 Vmm
			5 GND			2 Vmm	2 Vmm
			"			3 POV	3 POV
	1 DC24V					4 POV	4 POV
	5 GND					5 +24V	5 +24V
						6 24VGND	6 24VGND
					5 GND	7 GND	8 GND
					1 +5V	8 +5V	7 +5V

Power supply PCB in control box						PANEL BACK	Head PCB
P7	P8	P13	P14	P15	P16	6H	P12
			2 DC50V			1 Vmm	1 Vmm
			"			2 Vmm	2 Vmm
			6 GND			3 POV	3 POV
			"			4 POV	4 POV
	1 DC24V					5 +24V	5 +24V
	5 GND					6 24VGND	6 24VGND
					6 GND	7 GND	8 GND
					2 +5V	8 +5V	7 +5V

Cable signals

Power supply PCB in control box			PANEL BACK			BC PCB			
<b>P1</b>			1	<b>P4</b>					
1	+55V	-----	1	+55V	-----	1	+Vmm		
2	+55V		2	+55V		2	+Vmm		
5	+12V		3	+12V		3	+12V		
7	POV		4	GND		4	GND		
8	POV		5	GND		5	GND		
3	+55V		6	+55V		-----			
4	+55V		7	+55V		<b>P4</b>	1	+Vmm	
6	+12V		8	+12V		2	+Vmm		
9	POV		9	GND		3	+12V		
10	POV		10	GND		4	GND		
						5	GND		
<b>P2</b>			2	<b>P4</b>					
1	+55V		1	+55V		1	+Vmm		
2	+55V		2	+55V		2	+Vmm		
5	+12V		3	+12V		3	+12V		
7	POV		4	GND		4	GND		
8	POV		5	GND		5	GND		
3	+55V		6						
4	+55V		7						
6	+12V		8						
9	POV		9						
10	POV		10						
Power supply PCB in control box			PANEL BACK			Power supply PCB B in power supply base			
<b>P5</b>			5	<b>P1</b>					
1	DC24V	-----	1	DC24V	-----	1	DC24V		
2			2	GND		2	GND		
3	GND								
<b>P4</b>			4	<b>P6</b>					
1	DC50V	-----	1	DC50V	-----	1	DC50V		
2	DC50V		2	DC50V		4	DC50V		
3	GND		3	0V		3	GND		
4	GND		4	0V		6	GND		
						2			
						5			
<b>P11</b>			11	Transformer					
1	AC14V	-----	1	AC14V	-----	10	AC14V		
2	0V		2	0V		11	0V		
3									
4	AC14V					12	AC14V		
5	0V		3	AC14V		13	0V		
6			4	0V					
7	AC14V		5	AC14V		14	AC14V		
8	0V		6	0V		15	0V		
9									
10	AC14V		7	AC14V		16	AC14V		
11	0V		8	0V		17	0V		

## Cable signals

Power supply PCB in control box	PANEL BACK	Power supply PCB in control box
<b>P18</b> 1 AC200V 2 AC200V 3 FG	18 1 AC200V 2 AC200V 3 4 E	<b>P2</b> 1 AC200V 2 AC200V 3 4 FG
<b>P28</b> 1 +24V 2 0V	20B 1 SOL 2 0V	Pulley stop solenoid 1 + 2 -
<b>P26</b> 1 AC18V 2 3 AC18V	3 AC18V 4 AC18V	Power supply PCB B in power supply base <b>P7</b> 1 AC18VO 2 AC18VO
Power supply PCB B in power supply base	Bridge diode	
P14 +Red P13 -Black P12 ~ White P11 ~ White	+ - ~ ~	
<b>P5</b> 1 AC39V 2 AC39V 3 0V 4 0V	Transformer AC39V AC39V 0V 0V	
<b>P4</b> 1 AC18V 2 3 0V	AC18V 0V	
<b>P3</b> 1 2 3 4	Nozzle filter 3 4	

## 17-3. Connectors in power supply PCB B in power supply base

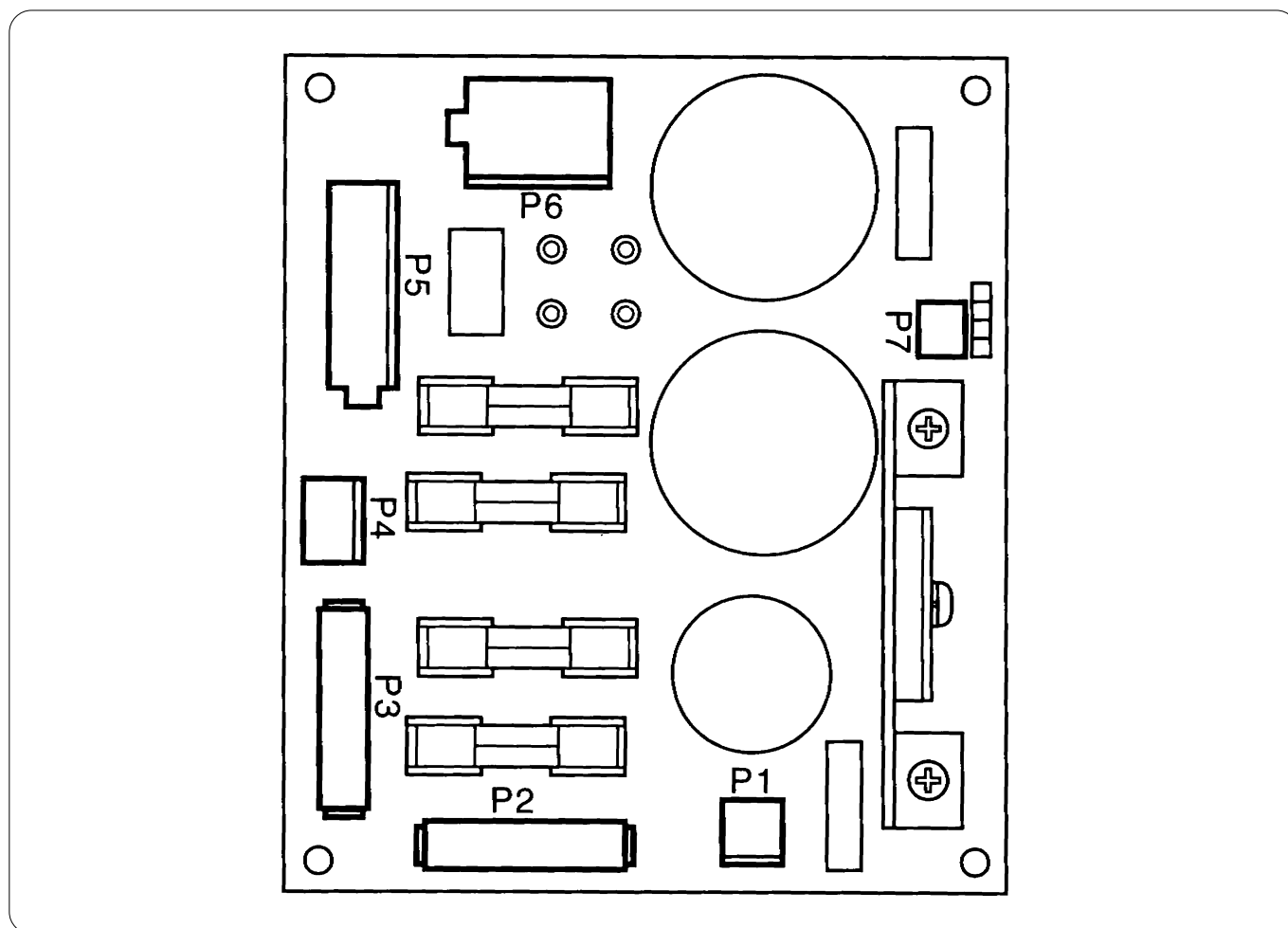

Connector No.	Connecting point	Drive signal	Symptoms resulting from improper connection or breakage
P1	Power supply PCB B - Power supply PCB in control box (P5)	+24V power supply	Error E-BA, E3, or D1 appears when power is turned on.
P2	Power supply PCB B - Power supply PCB in control box (P18)	AC200V power supply	Nothing works. POWER LED on panel is not lit.
P3	Power supply PCB B - Noise filter 3.4	AC power supply input	Nothing works. POWER LED on panel is not lit.
P4	Power supply PCB B - Transformer	AC18V input	Error E-BA, E3, or D1 appears when power is turned on.
P5	Power supply PCB B in power supply base - Transformer	AC39V input	Needle bar does not jump. Wiper does not work.
P6	Power supply PCB B - Power supply PCB in control box (P4)	DC50V output	The same above
P7	Power supply PCB B - Power supply PCB in control box (P26)	Power cut detection	Error E-BA appears when power is turned on.

### 17-4. Connector in panel PCB

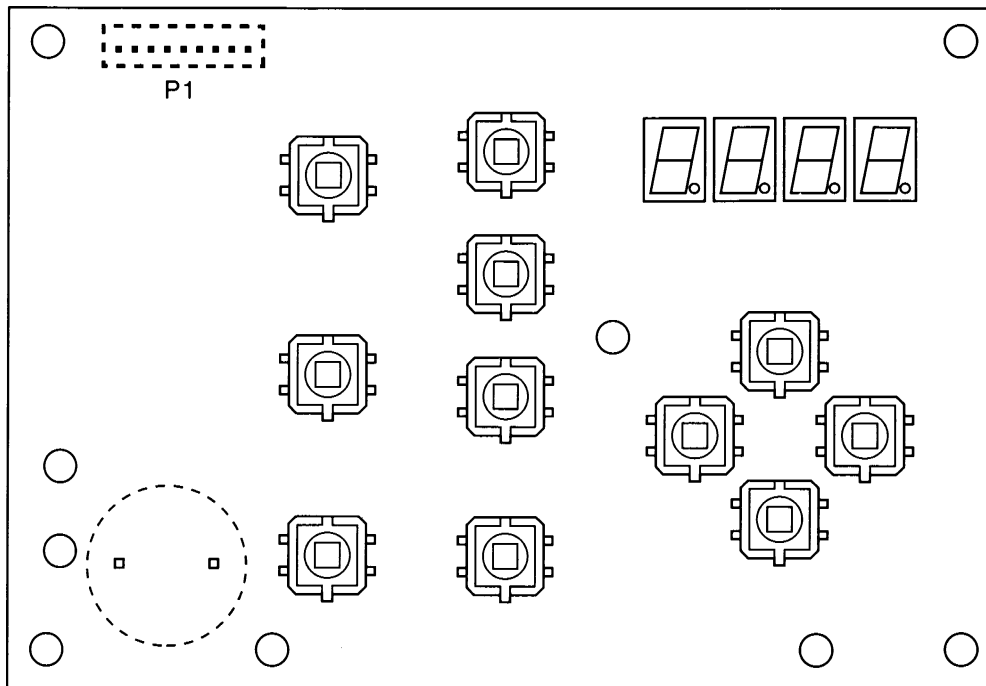

Connector No.	Connecting point	Drive signal	Symptoms resulting from improper connection or breakage
P1	Panel PCB - Main PCB (P29)	+5V power supply Communication line Stop switch	When power is turned on, the machine will work with its default settings but nothing will appear on the panel. POWER LED will not be lit.



### 17-5. Connectors in BC PCB

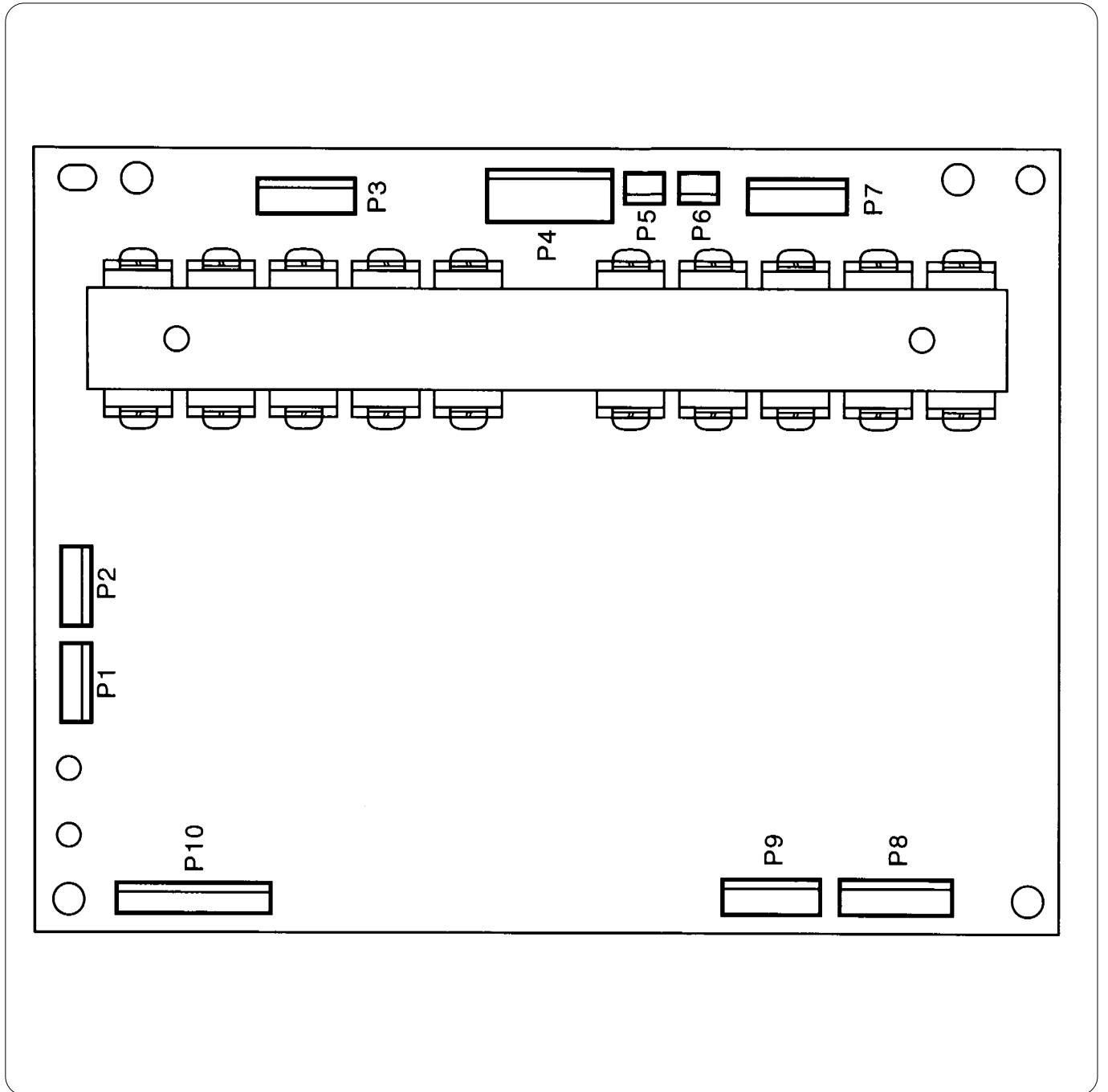

Connector No.	Connecting point	Drive signal	Symptoms resulting from improper connection or breakage
P1	BC PCB - Fixed bed lower shaft sensor	Lower shaft encoder input Thermister input	Error E-B2 appears when power is turned on.
P2	BC PCB - Retracting bed lower shaft sensor	Lower shaft encoder input Thermister input	Error E-B2 appears when power is turned on.
P3	BC PCB - Fixed bed lower shaft stepping motor	Motor output	Error E-B2 appears when power is turned on.
P4	BC PCB - Power supply PCB in control box	+55V power supply +12V power supply	Error E-B2 appears when power is turned on.
P5	BC PCB - Fixed bed DC fan motor	Fan power supply	Error E-B1 or E-B7 appears when power is turned on.
P6	BC PCB - Retracting bed DC fan motor	Fan power supply	The same above
P7	BC PCB - Retracting bed DC fan motor	Motor output	Error E-B2 appears when power is turned on.
P8	BC PCB - Main PCB or next BC PCB	Common control signal	Error E-B2 appears when power is turned on.
P9	BC PCB - Next BC PCB or terminal harness	Common control signal	Error E-B2 appears when power is turned on.
P10	BC PCB - Main PCB	+5V power supply Control signal	Error E-B2 appears when power is turned on.

## Cable signals

BC PCB			
P1	1	BENCA	BC sensor PCB (thermister) 1 PH1
	2	BENCB	2 PH2
	3	GND	3 0V
	4	BTHM	4 THM
	5	+5V	5 +5V
P2	1	BENCA	BC sensor PCB (thermister) 1 PH1
	2	BENCB	2 PH2
	3	GND	3 0V
	4	BTHM	4 THM
	5	+5V	5 +5V
P3 (LMOTOR)	1	A	Lower shaft motor 1 Black
	2	B	2 Blue
	3	C	3 Yellow
	4	D	4 Orange
	5	E	5 Red
P7 (RMOTOR)	1	A	Lower shaft motor 1 Black
	2	B	2 Blue
	3	C	3 Yellow
	4	D	4 Orange
	5	E	5 Red
P5 (LFAN)	1	+12V	Lower shaft DC fan motor 1 White +12V (red)
	2	GND	2 Black GND (black)
P6 (RFAN)	1	+12V	Lower shaft DC fan motor 1 White +12V (red)
	2	GND	2 Black GND (black)

## 17-6. Connectors in head PCB

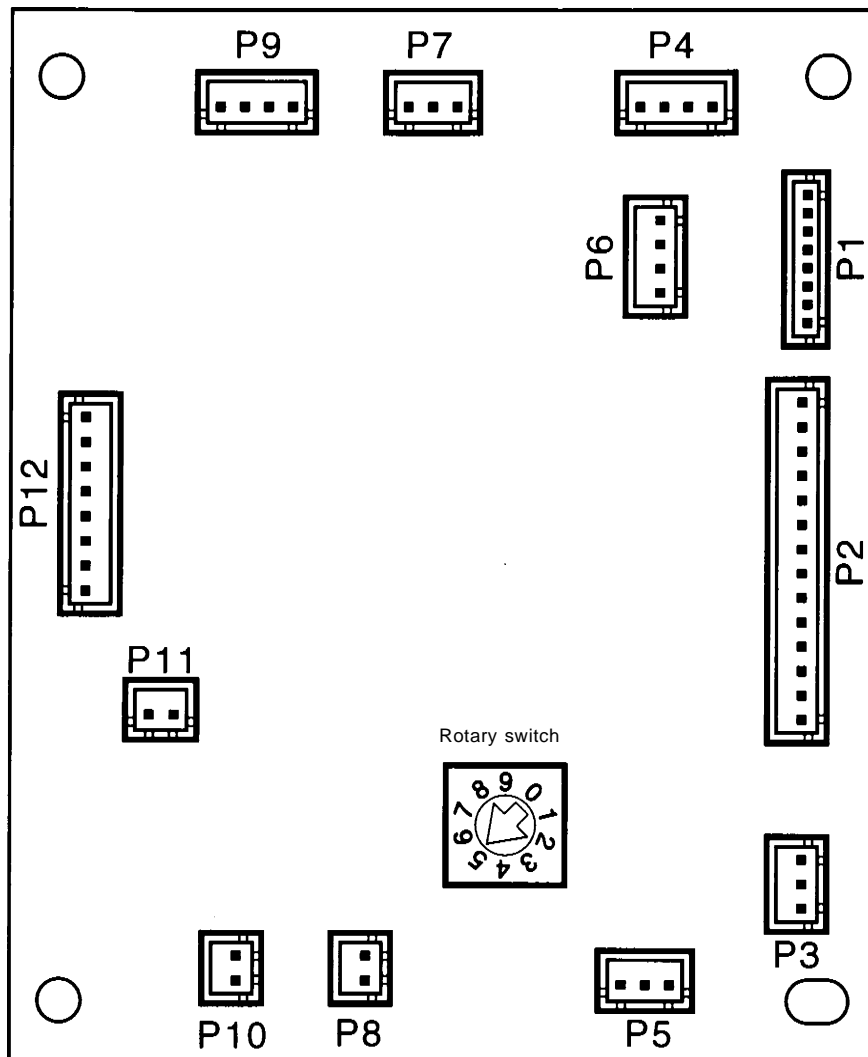

Rotary switch is used by setting it to the same number as the head to be used (1-6).

Connector No.	Connecting point	Drive signal	Symptoms resulting from improper connection or breakage
P1	Head PCB - Head switch PCB	Head switch POWER LED	Head switch malfunctions. Head LED is not lit.
P2	Head PCB - TR breakage sensor PCB	Sensor selection signal Sensor signal	Thread breakage detection often happens.
P3	Head PCB - Switch	Presser foot switch	When presser foot rises, a strange sound is made, and error E-C4 appears.
P4	Head PCB - Main PCB or next head PCB	Communication line	Error E-07 appears when power is turned on.
P5	Head PCB - Wiper sensor	Wiper sensor	When wiper has not retracted properly, it is not regarded as an error.
P6	Head PCB - Next head PCB or terminal harness	Communication line	Error E-07 appears when power is turned on.
P7	Head PCB - Needle position detection sensor (for head No.1 only: unused for other heads.)	Potentiometer	Error E-07 appears when power is turned on.
P8	Unused	For expansion Solenoid output	
P9	Head PCB - Presser foot motor	Presser foot motor output	Error E-C4 appears when power is turned on.
P10	Head PCB - Jump solenoid	Jump solenoid output	Needle bar does not jump.
P11	Head PCB - Wiper solenoid	Wiper solenoid output	Wiper does not work. Note: No error code appears.
P12	Head PCB - Power supply PCB in control box	+50V, +24V, +5V power supply	Error E-C4 appears when power is turned on.

## Cable signals

Head PCB			
<b>P7</b> (INDEX)	1 +5V 2 INDEX 3 GND	Needle bar position sensor 1 +5V 2 SIG 3 GND	
<b>P9</b> (F-PM)	1 A 2 $\bar{A}$ 3 B 4 $\bar{B}$	Presser foot motor 1 B Red 2 $\bar{B}$ Yellow 3 $\bar{A}$ Blue 4 A Orange	
<b>P-1</b> (H-SW)	1 +5V 2 $\overline{\text{MENDLED}}$ 3 $\overline{\text{UBKLED}}$ 4 $\overline{\text{MENDSW}}$ 5 $\overline{\text{OFFSW}}$ 6 $\overline{\text{FWDSW}}$ 7 $\overline{\text{BACKSW}}$ 8 GND	Relay connector 1 +5V 2 $\overline{\text{MENDLED}}$ 3 $\overline{\text{UBKLED}}$ 5 $\overline{\text{MENDSW}}$ 6 $\overline{\text{OFFSW}}$ 7 $\overline{\text{FWDSW}}$ 8 $\overline{\text{BACKSW}}$ 9 0V	Head switch PCB 1 +5V 2 $\overline{\text{MENDLED}}$ 3 $\overline{\text{UBKLED}}$ 4 $\overline{\text{MENDSW}}$ 5 $\overline{\text{OFFSW}}$ 6 $\overline{\text{FWDSW}}$ 7 $\overline{\text{BACKSW}}$ 8 GND 9 FG
<b>P2</b> (UPBRK)	1 NB1 2 NB2 3 NB3 4 NB4 5 NB5 6 NB6 7 NB7 8 NB8 9 NB9 10 NB10 11 NB11 12 NB12 13 UBRK 14 GND	Relay connector 1 NB1 2 NB2 3 NB3 4 NB4 5 NB5 6 NB6 7 NB7 8 NB8 9 NB9 10 UBRK 11 GND 12	TR breakage sensor PCB 1 PH1 2 PH2 3 PH3 4 PH4 5 PH5 6 PH6 7 PH7 8 PH8 9 PH9 10 UBRK(C-COM) 11 GND(E-COM)

Head PCB					
P3 (FSENS)	Presser foot sensor				
	1	+5V	_____	1	AN
	2	FOOT		2	C
	3	GND		3	COM
P5 (WSENS)	Wiper sensor				
	1	+5V	_____	1	AN
	2	WIPER		2	C
	3	GND		3	COM
P10 (JUNP)	Jump solenoid				
	1	Vmm	_____	1	J
	2	JSOL		2	
P11	Wiper solenoid				
	1	Vmm	_____	1	W
	2	WSOL		2	

### 17-7. Connectors on the rear of the control box

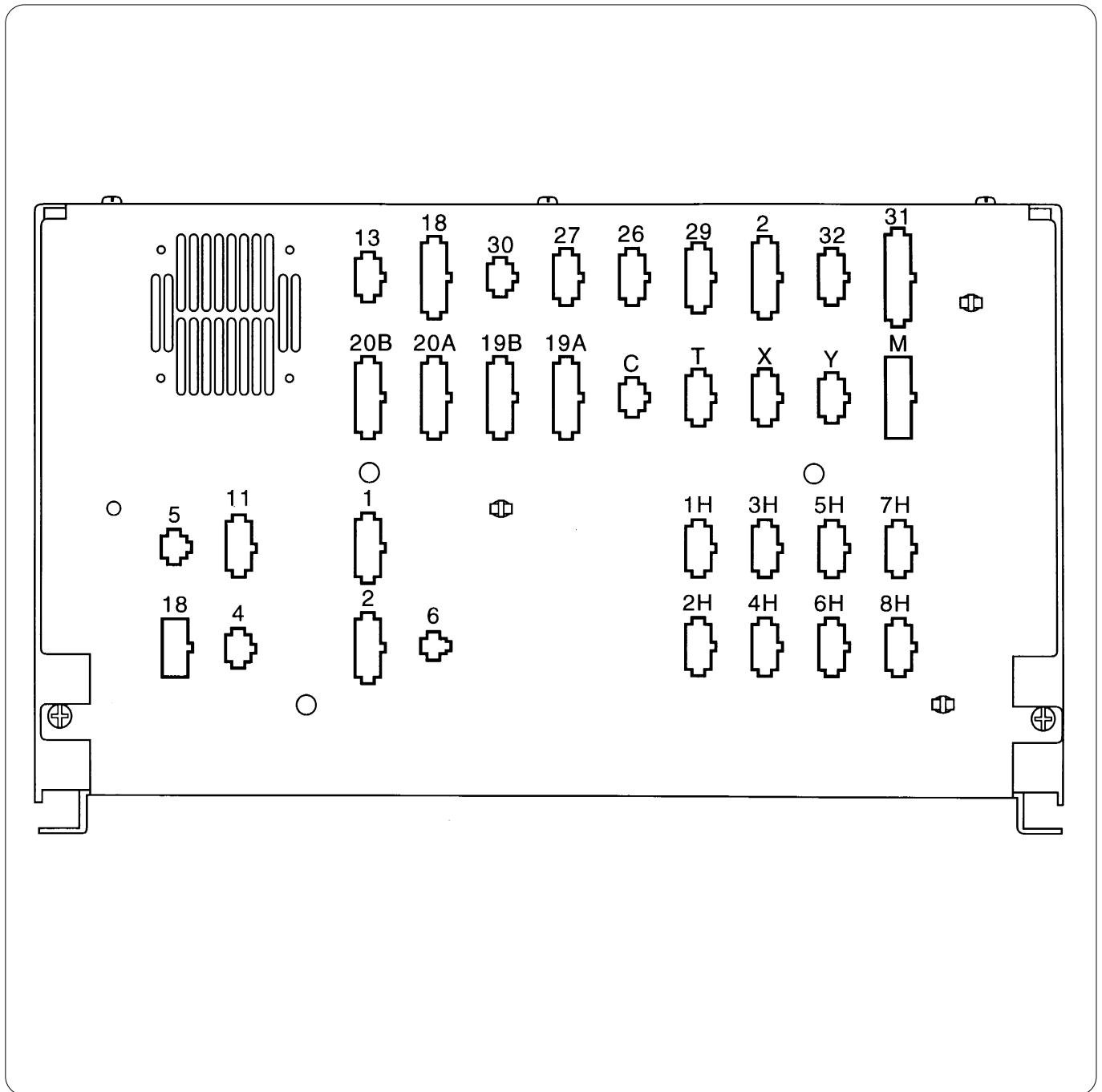



## Connectors on the rear of the control box

Connector No.	Connecting point	Symptoms resulting from improper connection or breakage
13	BC PCB (P8)	Error E-B2 appears when power is turned on.
18	Thread trimming sensor	Error E-B9 appears when power is turned on.
30	Head PCB (P4)	Error E-07 appears when power is turned on.
27	START - EM switch	STOP appears when power is turned on.
26	Needle position detection sensor and rotary encoder	Error E-A1 appears when power is turned on.
29	Operation panel	POWER LED is not lit when power is turned on, and any error appears.
2	Bed retracting sensor	Even when HEAD switch is on, no red lamps on heads Nos.2, 4, and 6 are lit, and embroidering can not be done. Presser feet of heads Nos. 2, 4, and 6 can not be retracted.
32	X area sensor	Error E-09 appears when power is turned on.
31	Y area sensor	Error E-14 appears when power is turned on.
20B	Power supply PCB B in power supply base (P26) - main shaft brake solenoid	Error E-BA appears when power is turned on.
20A	BC PCB (1) (P10)	Error E-B2 appears when power is turned on.
19B	BC PCB (2) (P10)	Error E-B2 appears when power is turned on.
19A	BC PCB (3) (P10)	Error E-B2 appears when power is turned on.
C	INDEX motor	Error E-07 appears when power is turned on.
T	Thread trimming motor	Error E-B9 appears when power is turned on.
X	X motor	Error E-18 appears when power is turned on.

## Connectors on the rear of the control box

Connector No.	Connecting point	Symptoms resulting from improper connection or breakage
Y	Y motor	Error E-14 appears when power is turned on.
M	Machine motor	Error E-A1 appears when embroidering starts.
1H-6H	Head PCB (P12)	Error E-07 or E-C4 appears when power is turned on.
7H-8H	Unused	
5	Power supply PCB B in power supply base (P1)	Error E-BA, E-E3, or E-D1 appears when power is turned on.
11	Transformer	Error E-A1 appears when power is turned on.
18	Power supply PCB B in power supply base (P2)	Nothing works. POWER LED on panel is not lit.
4	Power supply PCB B in power supply base (P6)	Needle bar does not jump. Wiper does not work. Note: No error code appears.
1	BC PCB (P4)	Error E-B2 appears when power is turned on.
2	BC PCB (P4)	Error E-B2 appears when power is turned on.
6	Bobbin winder motor	Bobbin winding can not be done when bobbin winder is connected.

# Chapter 8. Finding Cause of Problem

## 1. Mechanical problems

In case of a malfunction, diagnose the problem referring to the table below.  
 If the problem persists, turn off the power and contact your dealer.

Problem	Check point
Machine operates incorrectly.	<ul style="list-style-type: none"> <li>• Is set screw of rotary encoder loosened?</li> <li>• Is set screw of machine pulley loosened?</li> <li>• Is set screw of pulley B loosened?</li> <li>• Are timing belts for X- and Y-carriages loosened?</li> <li>• Are timing belts for X- and Y-carriages damaged?</li> <li>• Are set screws of pulleys A and B loosened?</li> <li>• Are set screws of couplings in X- and Y-pulse motors loosened?</li> <li>• Is sewing data in floppy disk normal?</li> </ul>
Upper shaft is locked at some point of a cycle.	<ul style="list-style-type: none"> <li>• Is thread take-up stopped with striking upper case cover? [HOW to adjust]</li> </ul> <div data-bbox="794 1077 1452 1361" style="text-align: center;"> <p>The diagram illustrates the thread take-up mechanism. It shows a vertical shaft with a thread take-up lever attached. The lever is connected to a set bolt. The upper case cover is positioned above the lever. The needle bar case and inner thread guide are also shown. The thread take-up operating lever is at the bottom of the mechanism.</p> </div> <p>Remove adjustment base.                      Loosen bolt of thread take-up coupled driving lever to adjust movable range of thread take-up. Then retighten it.</p> <ul style="list-style-type: none"> <li>• Are positions of needle bar clamp and top dead center stopper correct?</li> </ul>

## 2. Electrical parts

### Notes:

Before checking cable connections, be sure to turn off the sewing machine and remove the power supply plug from the socket.

When checking cable connections, perform continuity test between connectors.

In the Check and solution column, follow the items in order from the top.

Problem	Check and solution
<p>The power is turned on but the machine does not operate. The power LED on the panel is not lit either.</p>	<ul style="list-style-type: none"> <li>• Is the power plug of the machine correctly connected? Connect it properly.</li> <li>• Has the connector on the rear of the control box come off? Connect it properly while checking the connector number and harness number.</li> <li>• Have any connectors in the power supply base and inside the control box come off? Connect them after checking type and color.</li> <li>• Has fuse F1 or F2 of the power supply PCB inside the power supply base blown? Replace with a new one. If the either one blows again, there may be potential trouble. Is there any wrong wiring? If yes, replace the control box.</li> </ul>
<p>The power is turned on, but the machine does not operate. The STOP indication on the panel is blinking.</p>	<ul style="list-style-type: none"> <li>• Emergency stop switch remains activated? Reset the emergency stop switch.</li> </ul>
<p>When the power is turned on, the machine controller shows a message indicating the presser foot has been removed. The LED on machine head no.2, no.4, or no.6 does not come on, and the presser foot remains lowered.</p>	<ul style="list-style-type: none"> <li>• Is retracting bed sensor adjusted properly? Adjust the sensor on the machine head which is affected. (Refer to "Adjusting retracting bed sensor.")</li> <li>• Refer to the cable connection block diagram to check the connections from retracting bed sensor to the main PCB.</li> <li>• Is "every second head" set in the machine controller?</li> </ul>
<p>Error E-02 occurs.</p>	<ul style="list-style-type: none"> <li>• Is the frame out of cap frame area? Move the frame into the cap frame area, and turn on the power.</li> <li>• In PORT test mode, check ON/OFF signal of X area sensor. If the signal does not change, refer to the cable connection block diagram to check the connections from the X area sensor to the main PCB. If trouble still continues, replace the X area sensor</li> </ul>

<p>Error E-05 occurs.</p>	<ul style="list-style-type: none"> <li>• After the pulley is turned manually, is it beyond the stop angle? Turn the pulley manually until it is aligned with the stop position, and cancel the error.</li> <li>• In the encoder test mode, check the signal of the stop position sensor. Adjust or refer to the cable connection block diagram to check the connections from the needle position sensor to the main PCB. Replace the needle position sensor.</li> <li>• Does the main shaft brake solenoid operate? If not, refer to the cable connection block diagram to check the connections from the brake solenoid to the power supply PCB and between connector P27 on the power supply PCB and connector P1 on the main PCB.</li> <li>• Check the resistance of the main shaft brake solenoid at the connector of the solenoid. If it is approx. 50 ohms, it is OK. If it is nowhere near 50 ohms, replace the solenoid. In this case, the power supply PCB inside the control box may be broken. If the solenoid does not operate after replacement, replace the power supply PCB inside the control box.</li> <li>• Is there any problem with the main shaft mechanism such as a loose screw in the main shaft pulley?</li> </ul>
<p>Error E-07 occurs.</p>	<ul style="list-style-type: none"> <li>• Does the INDEX motor turn? If not, refer to the cable connection diagram to check the connections from the INDEX motor to the main PCB.</li> <li>• At the connector of the INDEX motor, check the resistance between pins 1 and 2, and pins 3 and 4. If they are approx. 4.4 ohms, they are OK. If they are nowhere near 4.4 ohms, replace the INDEX motor. If there is still problem after that, replace the main PCB.</li> <li>• Turn the color changing pulley manually. If it is too sluggish, adjust the color change mechanism and the needle bar case.</li> <li>• Deactivate the initial settings of the machine, and turn on the power. In SOL test mode, operate the head solenoids. When a head solenoid and the ones following it do not operate, refer to the cable connection diagram, and check the connection of the machine head communication line.</li> <li>• When only machine head 1 does not work Check the connection of communication line to machine head 1 and the power supply harness for machine head 1.</li> <li>• Does the setting of the rotary switch on the machine head PCB conform to each machine head? If not, adjust the setting of the rotary switch according to each machine head.</li> <li>• Deactivate the initial settings of the machine, and turn on the power. In CASE test mode, turn the color changing pulley manually. Does the figure on the panel change? If not, check the connection between the connector of the needle position sensor and connector P7 on machine head 1 PCB.</li> <li>• Replace the needle bar position sensor (potentiometer).</li> <li>• Replace machine head PCB 1.</li> </ul>

Error E-09 or E-14 occurs.	<ul style="list-style-type: none"> <li>• Does the XY carriage move? If it moves, refer to the cable connection diagram to check the connections from the XY area sensor to the main PCB.</li> <li>• Does the XY motor turn? If it turns, check the XY carriage mechanism.</li> <li>• If the XY motor does not turn, refer to the cable connection block diagram to check the connections from the XY motor to the main PCB.</li> </ul>
Error E-0A occurs even though thread has not broken.	<ul style="list-style-type: none"> <li>• In CASE test mode, activate the needle bars from no.1 in order using switches to find which needle bar has this problem. Turn the thread breakage sensor pulley corresponding to the needle bar which has the problem, and check whether the red LED on the machine head is blinking. If it is blinking, set the value of the thread breakage sensitivity in the machine controller to a lower number. (The standard is 10.)</li> <li>• When the red LED is not blinking, check the connections from thread breakage sensor PCB to the machine head PCB.</li> <li>• Replace the thread breakage sensor PCB.</li> </ul>
Error E-18 occurs.	<ul style="list-style-type: none"> <li>• Refer to the cable connection block diagram to check the connections from the two X motors on both sides to the main PCB.</li> </ul>
Error E-A1 occurs.	<ul style="list-style-type: none"> <li>• In "Ecd" test mode, turn the main shaft pulley manually. If it is too sluggish, the main shaft mechanism may have a problem.</li> <li>• With this error, does the main shaft motor turn? If it does not turn at all, check fuse F5 on the power supply PCB inside the control box. Refer to the cable connection block diagram to check the connections from the main shaft motor to the main PCB. Check the connections between connector P6 on the main PCB and connector P19 on the power supply PCB inside the control box, and between connector P4 on the main PCB and connector P12 on the power supply PCB inside the control box, and the connections from connector P11 on the power supply PCB to 14v terminal of the transformer.</li> <li>• In "Ecd" test mode, turn the main shaft pulley manually. Are the stop position signal and encoder signal correct? If either signal is not changed, refer to the cable connection block diagram to check the connections from the encoder, through the stop position sensor, to the main PCB.</li> </ul>
Error E-A8 occurs.	<ul style="list-style-type: none"> <li>• Check the upper shaft CPU ROM version. If it is version A, replace with a newer ROM whose version is B or later. (PROM #4 on the main PCB)</li> </ul>
Error E-B1 often occurs.	<ul style="list-style-type: none"> <li>• Is there any thread tangled around the rotary hook? Remove any waste thread from the rotary hook.</li> <li>• Conduct BC sensor test in PC test mode. If there is anything abnormal, replace the lower shaft module. (Refer to "Replacing the lower shaft module.")</li> </ul>

<p>Error E-B1 often occurs.</p>	<ul style="list-style-type: none"> <li>• In PC test mode, check the synchronization limitation among all lower shaft modules (auto test). If the test shows a lower shaft module whose timing is different from others, replace it. (Refer to "Replacing the lower shaft module.")</li> <li>• Check whether the lower shaft fan in the bed where the error often occurs turns normally. If the fan is not turning, check the connection between the lower shaft fan and the BC PCB. If trouble still continues though connection is OK, replace the lower shaft fan. If no lower shaft fan is turning, check fuse F4 on the power supply PCB in the control box.</li> <li>• Is the hole on the side of the bed where the error often occurs clogged with dust? Clean the hole</li> </ul>
<p>Error E-B2 occurs.</p>	<ul style="list-style-type: none"> <li>• Is there any thread tangled around the rotary hook? Remove any waste thread from the rotary hook.</li> <li>• Does the lower shaft where the error occurs turn? If it turns, check the connection between the lower shaft sensor PCB and the BC PCB. Adjust the lower shaft sensor. If trouble still continues, replace the lower shaft sensor PCB.</li> <li>• If the lower shaft where the error occurs does not turn, check the connection between the lower shaft motor and the BC PCB. Replace the lower shaft module. (Refer to "Replacing the lower shaft module.") Replace the BC PCB.</li> </ul>
<p>Error E-B3 occurs.</p>	<ul style="list-style-type: none"> <li>• Did you turn the rotary hook manually? If so, this is not error.</li> <li>• Check the connection between the lower shaft sensor PCB and the BC PCB. If trouble still continues, replace the lower shaft module. (Refer to "Replacing the lower shaft module.")</li> </ul>
<p>Error E-B7 occurs.</p>	<ul style="list-style-type: none"> <li>• Make sure that the lower shaft fan turns normally. If the fan is not turning, check the connection between the lower shaft fan and the BC PCB. If trouble still continues, replace the lower shaft fan. If no lower shaft fan is turning, check fuse F4 on the power supply PCB in the control box.</li> <li>• Is the hole on the side of the bed where the error often occurs clogged with dust? Clean the hole.</li> <li>• Check the connections from the thermistor in the lower shaft module to the BC PCB.</li> </ul>
<p>Error E-B8 occurs.</p>	<ul style="list-style-type: none"> <li>• Does the red LED for the BC PCB go off? If not, refer to the cable connection block diagram to check the connections from the BC PCB to the main PCB.</li> <li>• Check the connections from the lower shaft motor to the BC PCB in the bed whose red LED is off. If there is a short circuit because of a wire being caught, replace a harness or lower shaft module. (Refer to "Replacing the lower shaft module.")</li> <li>• Using a tester, measure the resistance between the following pairs of pins in the connector of the lower shaft motor: pins 1 and 2, pins 2 and 3, pins 3 and 4, pins 4 and 5, and pins 5 and 1. Make sure that resistance is approx. 2.6 ohms. If there is anything abnormal, replace the lower shaft module. (Refer to "Replacing the lower shaft module.")</li> <li>• Replace the BC PCB.</li> </ul>

Error E-B9 occurs.	<ul style="list-style-type: none"> <li>• Is waste thread tangled around the movable knife? Clean it.</li> <li>• Does the thread trimming motor run? If it runs, refer to the cable connection block diagram to check the connections from the thread trimming sensor to the main PCB. If trouble still continues, adjust the thread trimming sensor PCB. (Refer to "Replacing the thread trimming sensor PCB.")</li> <li>• If it does not run, refer to the cable connection block diagram to check the connections from the thread trimming motor to the main PCB.</li> <li>• Check the connection between connector P3 on the main PCB and connector P9 on the power supply PCB inside the control box.</li> <li>• Check fuse F6 of the power supply PCB inside the control box. When the fuse has blown, replace it with a new one. If it blows again, replace the power supply PCB.</li> </ul>
Error E-BA occurs.	<ul style="list-style-type: none"> <li>• Check the connection between connector P16 on the main PCB and connector P10 on the power supply PCB inside the control box.</li> <li>• Refer to the cable connection block diagram to check the connections from connector P26 on the power supply PCB inside the control box to connector P7 on the power supply PCB in the power supply base.</li> <li>• Check fuse F3 of the power supply PCB in the power supply base. When the fuse has blown, replace it with a new one. If it blows again, there may be a problem in the 24v circuit.</li> </ul>
Error E-C2 occurs.	<ul style="list-style-type: none"> <li>• Does the wiper in the erroneous machine head remain advanced? If a thread is tangled, remove it. If the wiper does not retract smoothly, adjust it.</li> <li>• In SOL test mode, check the figure indicated on the panel. If it is not S-00, check the connection between the wiper sensor and the machine head PCB. Replace the wiper sensor. Replace the machine head PCB.</li> </ul>
Error E-C3 occurs. NOTE This error may rarely occur according to your PC's performance. If it occurs, check the items shown on the left.	<ul style="list-style-type: none"> <li>• Has the IF cable come off?</li> <li>• Has the RS cable on the PC come off?</li> <li>• Is the PC or machine controller down? Reboot the PC or machine controller.</li> <li>• Replace the IF cable.</li> </ul>
Error E-C4 occurs.	<ul style="list-style-type: none"> <li>• Is the presser foot attached? If not, attach it.</li> <li>• When the presser foot rises to the top and immediately lowers Adjust the presser foot sensor.</li> <li>• When the presser foot rises to the top and generates noise for a while Check the connections from the presser foot sensor to the machine head PCB. Replace the presser foot sensor. Replace the machine head PCB.</li> <li>• When the presser foot does not move at all Check the connections from the presser foot motor to the machine head PCB. Replace the presser foot motor. Replace the machine head PCB.</li> </ul>



<p>Error E-CB occurs.</p>	<ul style="list-style-type: none"> <li>• In ENC test mode, turn the main shaft pulley manually. If it is too sluggish, there is a problem in the main shaft mechanism.</li> <li>• Refer to the cable connection block diagram to check the connections from the main shaft motor to the main PCB. Check the connections between connector P6 on the main PCB and connector P19 on the power supply PCB inside the control box, and between connector P4 on the main PCB and connector P12 on the power supply PCB inside the control box, and the connections from connector P11 on the power supply PCB to 14v terminal of the transformer.</li> </ul>
<p>Error E-CE occurs.</p>	<ul style="list-style-type: none"> <li>• Is retracting bed sensor adjusted properly? Adjust the sensor on the machine head which is affected. (Refer to retracting bed sensor adjustment.)</li> </ul>
<p>Error E-D0 occurs.</p>	<ul style="list-style-type: none"> <li>• Check the connection between connector P16 on the main PCB and connector P10 on the power supply PCB inside the control box.</li> <li>• Refer to the cable connection block diagram to check the connections from connector P4 on the BC PCB to the power supply PCB inside the control box, and between connector P9 on the main PCB and connector P3 on the power supply PCB inside the control box.</li> <li>• Replace the power supply PCB.</li> <li>• Replace the main PCB.</li> </ul>
<p>Error E-D1 occurs. Error E-E3 occurs. Three fans in the control box have stopped.</p>	<ul style="list-style-type: none"> <li>• Refer to the cable connection block diagram to check the connections between connector P5 on the power supply PCB inside the control box and connector P1 on the power supply PCB in the power supply base, and between connector P4 on the power supply PCB in the power supply base and 18v terminal of the transformer.</li> <li>• Check fuse F3 of the power supply PCB in the power supply base. When the fuse has blown, replace it with a new one. If it blows again, there may be a problem in the 24v circuit.</li> </ul>
<p>Only error E-D1 occurs.</p>	<ul style="list-style-type: none"> <li>• Make sure that cooling fans on the left of the main PCB and at the rear of the power supply PCB turn. When either fan is stopped, check the connection between stopped fan and connector P20 or P25 on the power supply PCB inside the control box. If there is no connection problem, replace the stopped fan.</li> <li>• When both fans turn Check the connection between connector P16 on the main PCB and connector P10 on the power supply PCB inside the control box. Replace the main PCB.</li> </ul>
<p>Only error E-E3 occurs.</p>	<ul style="list-style-type: none"> <li>• Make sure that the cooling fan on the right of the main PCB turns. When it is stopped, check the connection between the cooling fan and connector P12 on the main PCB. If there is no connection problem, replace the stopped fan.</li> <li>• When the fan turns Replace the main PCB.</li> </ul>

<p>Error E-D2 occurs. Error E-D3 occurs.</p>	<ul style="list-style-type: none"> <li>• Is voltage setting done in machine controller? If it is not set, set the power supply voltage as specified in the area the machine is used.</li> <li>• Is the transformer's tap voltage (at terminal indicated as "T") equal to power supply voltage where the machine is used? If not, change the connection of the terminal.</li> <li>• In AC test mode on the machine, check the figure of the input voltage and using a tester, measure the power supply voltage for comparison. When the measured voltage value is greatly different (more than plus/minus 5 volts), rectify the voltage in PC test mode.</li> <li>• If this error often occurs and the machine cannot go into the test mode, change the voltage setting in the machine controller to a higher number for error E-D2 or a lower number for error E-D3, to prevent reoccurrence of error. Check it in the test mode for rectification.</li> <li>• Check the connection between connector P16 on the main PCB and connector P10 on the power supply PCB inside the control box.</li> <li>• Does the power supply sharply drop for a machine with a large capacity such as a compressor? Separate the power source to the machine and compressor, or use a stabilizer.</li> <li>• Replace the power supply PCB. If trouble still continues, replace the main PCB.</li> </ul>
<p>Error E-E1 occurs.</p>	<ul style="list-style-type: none"> <li>• At the respective connectors of the two X-axis motors, measure the resistance between pins 1 and 2, pins 2 and 3, pins 3 and 4, pins 4 and 5, pins 5 and 1 using a tester. It is OK if the resistance is approx. 2.1 ohms. If there is anything abnormal, replace the motor.</li> <li>• Refer to the cable connection block diagram to check the connections from the X-axis motor to the main PCB.</li> <li>• Replace the main PCB.</li> </ul>
<p>Error E-E2 occurs.</p>	<ul style="list-style-type: none"> <li>• At the respective connectors of the Y-axis motor, measure the resistance between pins 1 and 2, pins 2 and 3, pins 3 and 4, pins 4 and 5, pins 5 and 1 using a tester. It is OK if the resistance is approx. 2.4 ohms. If there is anything abnormal, replace the motor.</li> <li>• Refer to the cable connection block diagram to check the connections from the Y-axis motor to the main PCB.</li> <li>• Replace the main PCB.</li> </ul>
<p>Error E-E4 occurs.</p>	<ul style="list-style-type: none"> <li>• In PC test mode, is the lower shaft being tested? If it is being tested, refer to the page indicating how to operate in PC test mode to finish the test mode or turn the power off and then on again.</li> <li>• Turn the power off and then on again. If the error occurs again, replace the main PCB.</li> </ul>
<p>The following errors occur: E-BD, BE, E5 to FF</p>	<p>Replace the main PCB.</p>

<p>Jump solenoids and wiper solenoids on all the machine heads do not work.</p>	<ul style="list-style-type: none"> <li>• Refer to the cable connection block diagram to check the connections from connector P4 on the power supply PCB inside the control box to connector P6 on the power supply PCB in the power supply base, and from connector P5 on the power supply PCB in the power supply base to 39 v terminal of the transformer.</li> <li>• Check fuse F4 on the power supply PCB in the power supply base. When it has blown, replace it. When the power is turned on after replacement and it immediately blows again, the 50 v circuit has a problem.</li> </ul>
<p>Jump solenoid does not work.</p>	<ul style="list-style-type: none"> <li>• Check the connections from jump solenoid to connector P10 on the machine head PCB.</li> <li>• Check the resistance for a jump solenoid that does not work, at the connector. It is OK if the resistance is approx. 56 ohms. If it is nowhere near 56 ohms, replace the solenoid. In this case, machine head PCB may be out of order. When even a new solenoid does not work, replace the machine head PCB.</li> <li>• Refer to the cable connection block diagram to check the connections from connector P12 on the machine head PCB to connectors P7, P8, P13, P14, P15, and P16 on the power supply PCB inside the control box.</li> <li>• Replace the machine head PCB.</li> </ul>
<p>Wiper solenoid does not work.</p>	<ul style="list-style-type: none"> <li>• Check the connections from wiper solenoid to connector P11 on the machine head PCB.</li> <li>• Check the resistance for a wiper solenoid that does not work, at the connector. It is OK if the resistance is approx. 28 ohms. If it is nowhere near 28 ohms, replace the solenoid. In this case, machine head PCB may be out of order. When even a new solenoid does not work, replace the machine head PCB.</li> <li>• Refer to the cable connection block diagram to check the connections from connector P12 on the machine head PCB to connectors P7, P8, P13, P14, P15, and P16 on the power supply PCB inside the control box.</li> <li>• Replace the machine head PCB.</li> </ul>
<p>The BC PCB has an abnormality.</p>	<ul style="list-style-type: none"> <li>• Turn off the machine power.</li> <li>• Separate connectors P4 and P10 from the BC PCB.</li> <li>• At this time, if the BC PCB is removed from the machine or connectors P8 and P9 are separated from the PCB, a lower shaft connected to other BC PCB can not work.</li> <li>• Turn on the power.</li> <li>• Error E-B2 will occur. The green LEDs on the two machine heads controlled by the defective BC PCB will blink. Press the HEAD switch on the machine head downward (off), and press the MENDING switch upward until the green LED goes off.</li> <li>• After all green LEDs go off, press the STOP key on the panel or step back key on the machine head to cancel the error.</li> </ul>











The lower shaft module has an abnormality.





- Turn off the machine power.
- Separate connectors P1, P3, and P5 for fixed bed or P2, P4, and P6 for retracting bed, from the defective lower shaft module.
- Turn on the machine power.
- Error E-B2 will occur. The green LEDs on the two machine heads controlled by the defective BC PCB will blink. Press the HEAD switch on the machine head downward (off), and press the MENDING switch upward until the green LED goes off.
- After all green LEDs go off, press the STOP key on the panel or step back key on the machine head to cancel the error.









**Note:**

The operation above is to stop the operations of the lower shaft and lower shaft module which are connected to a defective BC PCB, resulting in causing the corresponding machine head to pause. The pause can be canceled by turning on the machine power. When you want to stop the operations of the lower shaft and lower shaft module again, return to step 3.

# Chapter 9 Error code list

Code	Error	Measures
E-00	No error occurs.	This code does not usually appear.
E-01	Either motor of main shaft, X- or Y-axis, or lower shaft has locked.	This code does not usually appear.
E-02	Overtravel occurs during home position detecting movement.	Turn the power off once, then on again. If the same error occurs again, the area sensor is faulty.
E-03	The stop switch is pressed during home position detecting movement.	Press  and clear the error message. Pressing  restarts the home position detecting movement again.
E-04	Zero detecting movement out of range	Turn the power off once, then on again. If the same error occurs again, the X- or Y-axis mechanism is faulty.
E-05	Needle stop position error	Adjust the pulley stop position (100°) above the needle and press  .
E-06	Needle bar case position error	Press  . If the error persists, the color-change mechanism is faulty.
E-07	Needle bar case lock	
E-09	X-axis home position detection error	Turn the power off once, then on again. If the same error occurs again, the X-axis mechanism is faulty.
E-0A	Thread breakage error	After passing through the thread, press  .
E-0B	Stop or emergency stop during sewing	This code does not usually appear.
E-0C	Insufficient bobbin thread	This code does not usually appear.
E-0D	The machine does not return to the home position.	Turn power off and then on again.
E-0E	Mending finish	This code does not usually appear.
E-14	Y-axis home position detection error	Turn the power off once, then on again. If the same error occurs again, the Y-axis mechanism is faulty.
E-15	Stop key was pressed while hoop was moving during non-sewing.	
E-16	Needle with specified number sent from PC is out of movable area.	This code does not usually appear.
E-17	Speed Vol. No. sent from PC is out of range.	This code does not usually appear.
E-18	X-axis stepping motor connector error	Check that the connector of the X-axis stepping motor is properly connected, and turn power off and then on again.
E-1A	Destination coordinates error	This code does not usually appear.
E-1B	The machine has reached the mending stop position.	This code does not usually appear.
E-1C	The machine stops during mask tracing.	Press the  key to cancel tracing. Press the  key to continue tracing.
E-1D	The machine stops while the needle is moving between patterns during repeat sewing.	Press the  key to continue tracing.
E-1E	When the power is turned on, bed can not be retracted.	Remove the presser foot from the retracting bed. If the bed is not retracted, the retraction sensor is the cause.
E-1F	Presser foot down error while searching for home position just after the power is turned on.	Press the  key on the operation panel. If the error occurs again, adjust the presser foot switch.
E-21	Hoop overhang (+X)	Set the embroidering area again on the personal computer or move the hoop to a sewable position. (The hoop can be moved to a sewable position by pressing  .)
E-22	Hoop overhang (+Y)	
E-23	Hoop overhang (+X, +Y)	
E-24	Hoop overhang (-X)	
E-25	Hoop overhang (+X, -X)	
E-26	Hoop overhang (-X, +Y)	

Code	Error	Measures
E-27	Hoop overhang (+X, -X, +Y)	Set the embroidering area again on the personal computer or move the hoop to a sewable position. (The hoop can be moved to a sewable position by pressing  .)
E-28	Hoop overhang (-Y)	
E-29	Hoop overhang (+X, -Y)	
E-2A	Hoop overhang (+Y, -Y)	
E-2B	Hoop overhang (+X, +Y, -Y)	
E-2C	Hoop overhang (-X, -Y)	
E-2D	Hoop overhang (+X, -X, -Y)	
E-2E	Hoop overhang (-X, +Y, -Y)	
E-2F	Hoop overhang (+X, -X, +Y, -Y)	Set the embroidering area again on the personal computer or move the hoop to a sewable position.
E-31	Needle overhang (+X)	
E-32	Needle overhang (+Y)	
E-33	Needle overhang (+X, +Y)	
E-34	Needle overhang (-X)	
E-36	Needle overhang (-X, +Y)	
E-38	Needle overhang (-Y)	
E-39	Needle overhang (+X, -Y)	
E-40	The status of the presser foot is issued as an alarm when every second machine is used.	Remove the presser foot according to the message on display (when every second machine is used).
E-3C	Needle overhang (-X, -Y)	Set the embroidering area again on the personal computer or move the hoop to a sewable position.
E-A1	Spindle motor lock	Press  . If the same error occurs frequently, the spindle mechanism is faulty.
E-A2	Main PC board temperature too high	Turn the power off once, then on again. If the same error occurs again, the spindle motor or main PC board is faulty.
E-A3	Spindle motor voltage too low	
E-A4	Spindle motor voltage too high	
E-A5	Main shaft motor CPU communication error	
E-A6	Main shaft motor CPU communication command error	
E-A7	Main shaft motor CPU send/receive error	
E-A8	Main shaft stop position signal error	Turn the pulley to set the needle up stop position (100 degrees), and press the  key on the operation panel. If the error often occurs, the main shaft stop position sensor may be defective.
E-B0	Lower shaft CPU error Press u.	Turn the power off once, then on again. If the same error occurs again, the spindle motor or main PC board is faulty.
E-B1	Thread tangle in rotary hook	Check that no tint is tangled in the rotary hook and press
E-B2	Lower shaft motor zero point error	
E-B3	Lower shaft standby position error	Press  .
E-B4	Lower shaft motor mode error	
E-B5	Lower shaft communication error	
E-B6	Lower shaft parameter error	

Code	Error	Measures
E-B7	Lower shaft overheat error	Turn the power off once, then on again. If the same error occurs again, the lower shaft or fan motor is stopped main PC board is faulty.
E-B8	Lower shaft motor overcurrent error	
E-B9	Thread trimming motor zero point error	Turn the power off, and check the thread trimming mechanism. Press u . If the same error occurs again, the thread trimming mechanism is faulty.
E-BA	Power frequency error	Turn the power off once, then on again. If the same error occurs again, the power PC board or power supply is faulty.
E-BC	Service interruption error	Press  .
E-BD	Lower shaft flash memory error	Turn the power off once, then on again. If the same error occurs, the main PC board is faulty.
E-BE	Lower shaft version-up error	Press R and clear the error display and upgrade the verslon agam.
E-BF	Lower shaft motor undefined error	This code does not usually appear.
E-C1	Area over during embroidering	Set the embroidering area again on the personal computer.
E-C2	Wiper out error	If the wiper is tangled with a thread, remove it. Then press  .
E-C3	Embroidering data buffer empty	IF cable is disconnected. If it is connected, IF cable or main PCB may malfunction .
E-C4	Presser foot down error	Press  .
E-C5	Measured voltage value could not be received from the lower shaft motor CPU.	This code does not usually appear.
E-C6	Voltage value could not be transferred to the lower shaft motor CPU.	This code does not usually appear.
E-C8	Lower shaft motor home position error	Check the operation of the main shaft brake and the main shaft stop position (100 degrees).
E-C9	Embroidering start error	Press  . Check that the READY lamp is on, before pressing  .
E-CA	No sewing permission from PC	This code does not usually appear.
E-CB	Spindle rotation speed error	Press  and clearthe error dsplay. Then press  . If the same error occurs again, there is a possibility that the spindle is overloaded.
E-CD	Speed command can not be received.	Turn power off and then on again. If the error occurs again, the main PCB may be defective.
E-CE	Cylinder bed position error	Secure to bed.
E-CF	Rated voltage value could not be received from the lower shaft motor CPU.	Turn power off and then on again. If the error occurs again, the main PCB may be defective.
E-DO	Power PC board error	Turn the power off once, then on again. If the same error occurs again, the power PC board is faulty.
E-D1	Cooling fan motor stop B Turn the power off.	Check that the fan on the left or bottom rear of the control box is not tangled with a hames, etc. before turning tie power on ag If the same error occurs again, the fan or the power PC board is faulty.
E-D2	Power voltage upper iimit error	Press  . If the same error occurs again, the power PC board or the power supply js faulty.
E-D3	Power voltage lower limit error	Turn the power off once, then on again. If the same error occurs again, the pulse motor or the main PC.
E-E1	X-axis pulse motor overcurrent stop	
E-E2	Y-axis pulse motor overcurrent stop	If "OFF" is displayed, turn the power off. Check that the fan at the right rear of the control box is not tangled with a harness, etc. before turning the power on again. If the same error occurs again, the fan or the power PC board is faulty.
E-E3	Cooling fan motor stop A Press R .	
E-E4	Lower shaft communication error	Turn power off and then on again. If the error occurs again, the main PCB may be defective.
E-E5	Over-run error during interfacing to main PCB CPU	This code does not usually appear.
E-E6	Framing error during interfacing to main PCB CPU	

Code	Error	Measures
E-E7	Parity error during interfacing to main PCB CPU	This code does not usually appear.
E-E8	Receiving time up error during interfacing to main PCB CPU	
E-E9	Send/Receive inconsistent error during interfacing to main PCB CPU	
E-EA	ACK code receiving error during interfacing to main PCB CPU	
E-EB	Send/Receive ID code error during interfacing to main PCB CPU	
E-EC	Send data checksum error during interfacing to main PCB CPU	
E-ED	Data empty error during interfacing to main PCB CPU	
E-EF	Receiving error on interface	
E-F1	Send time up error	
E-F2	Request-to-send waiting time up error	
E-F3	Request-to-receive time up error	
E-F4	Receive command error	
E-F5	NACK code receiving error	
E-F6	Data requested for needle position can not be returned.	
E-F7	It is not receive command for the request one.	
E-F8	PRE code error	
E-F9	No applicable command	
E-FA	Interface receive data sum check error	
E-FB	Send time up error	
E-FF	No status is returned from main shaft, lower shaft motor, or CPU.	



### 3. Test mode menu list

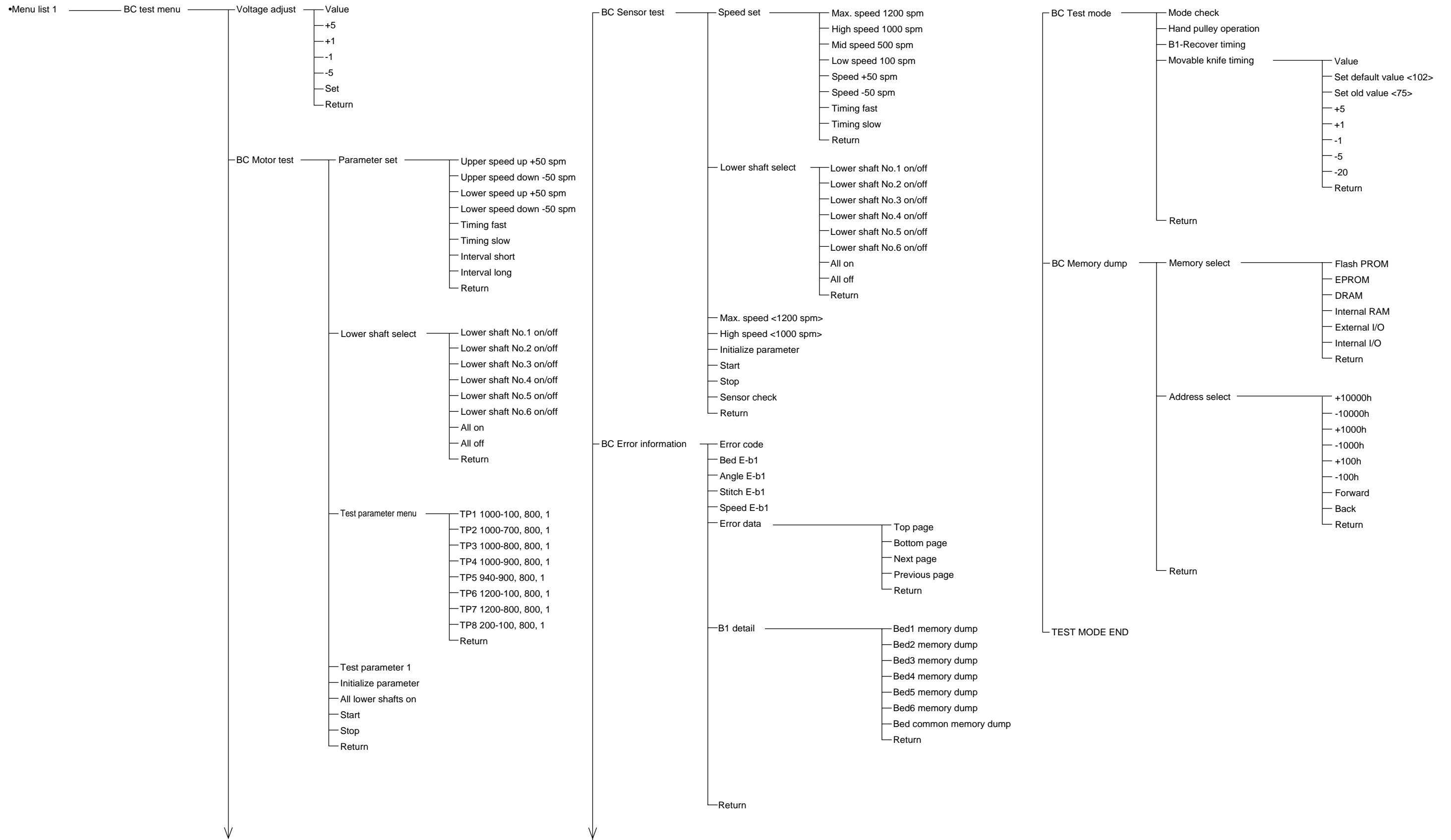

# Control Block Diagram (BES-960BC, 1260BC)

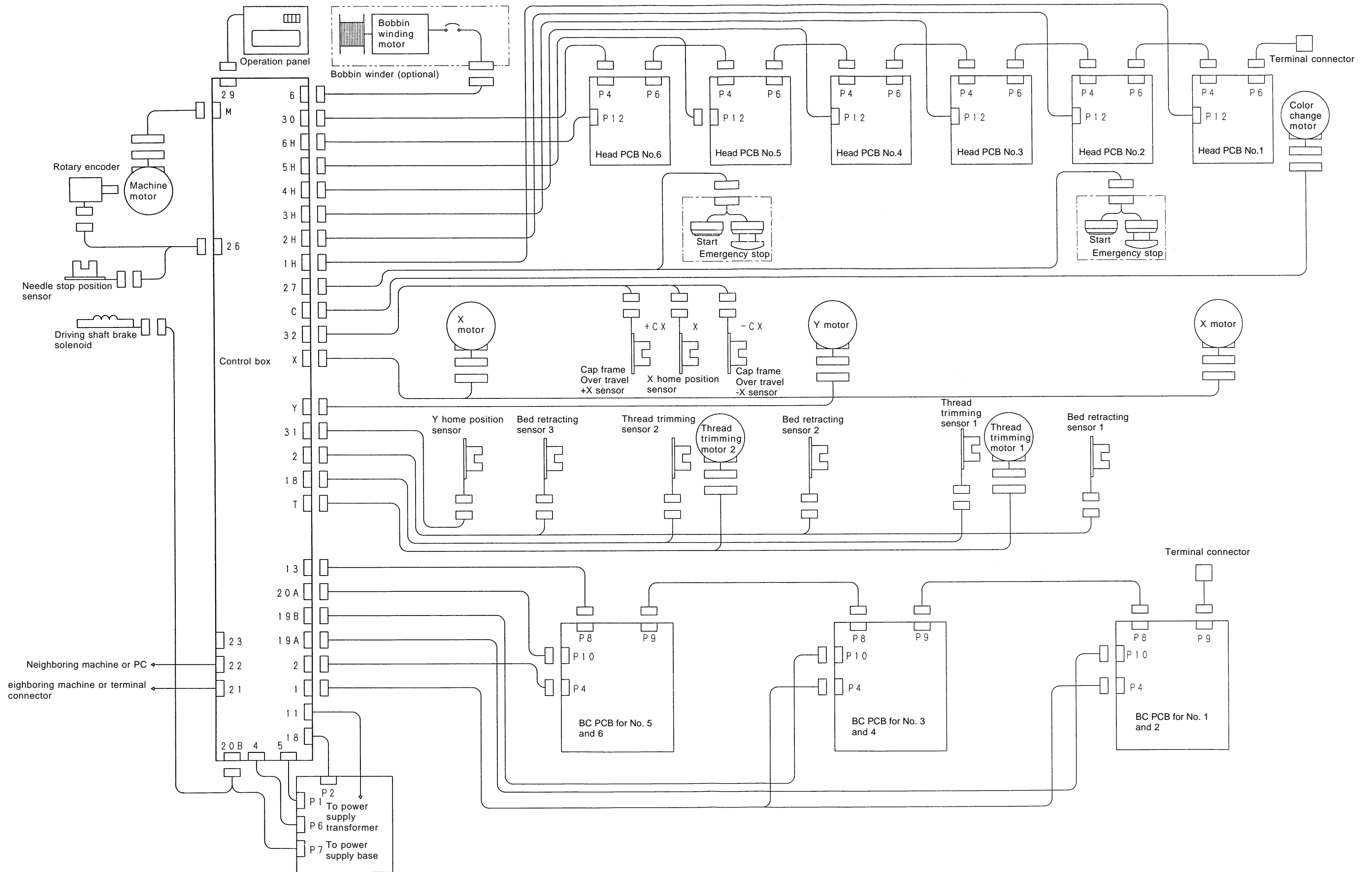

# Control box (BES-960BC, 1260BC)

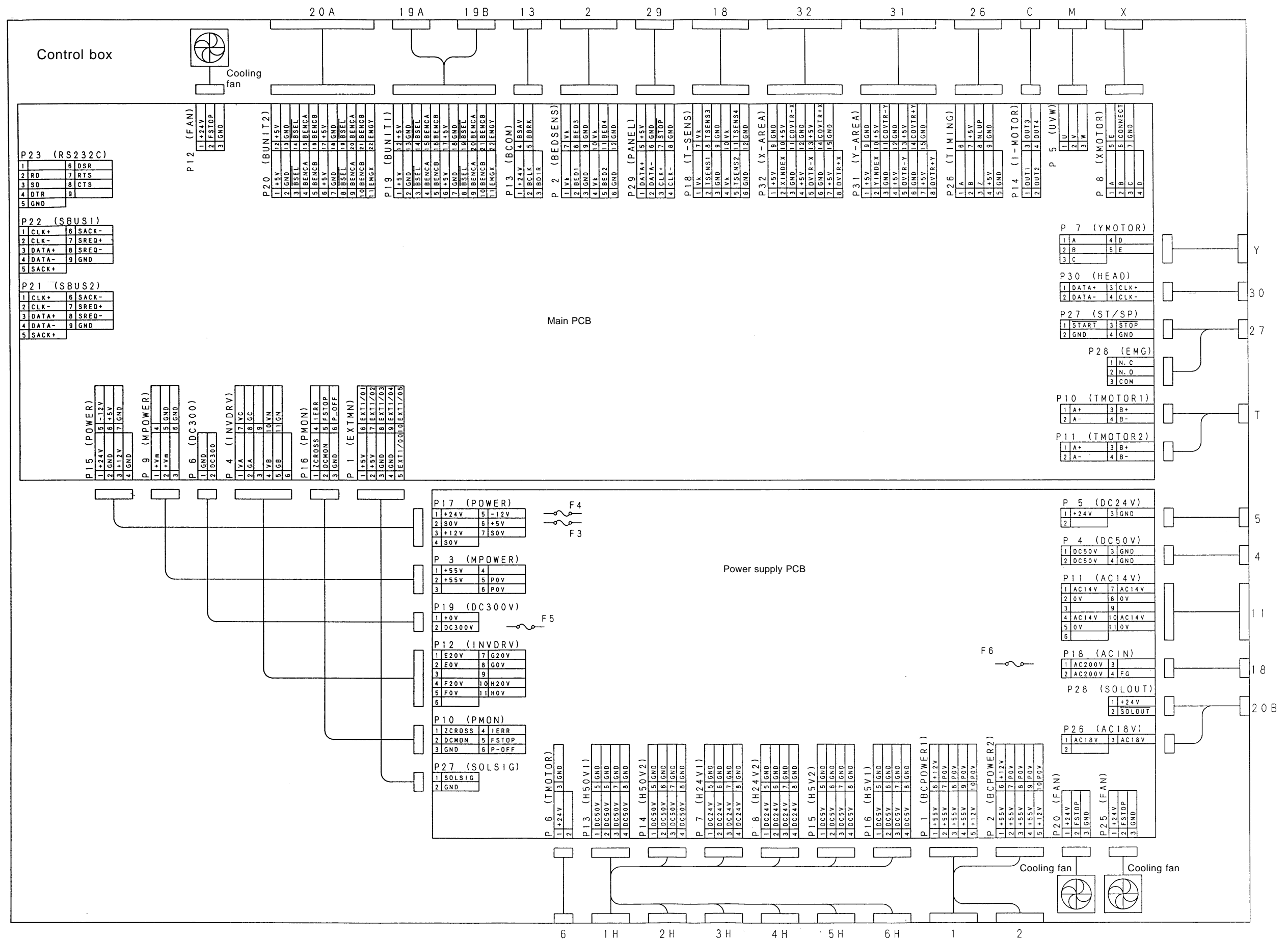

# Heads (1-6) (BES-960BC)

## Heads (1-6)

Rotary switch is used by setting it to the same number as the head to be used.

Head no.	Switch no.
1	1
2	2
3	3
4	4
5	5
6	6

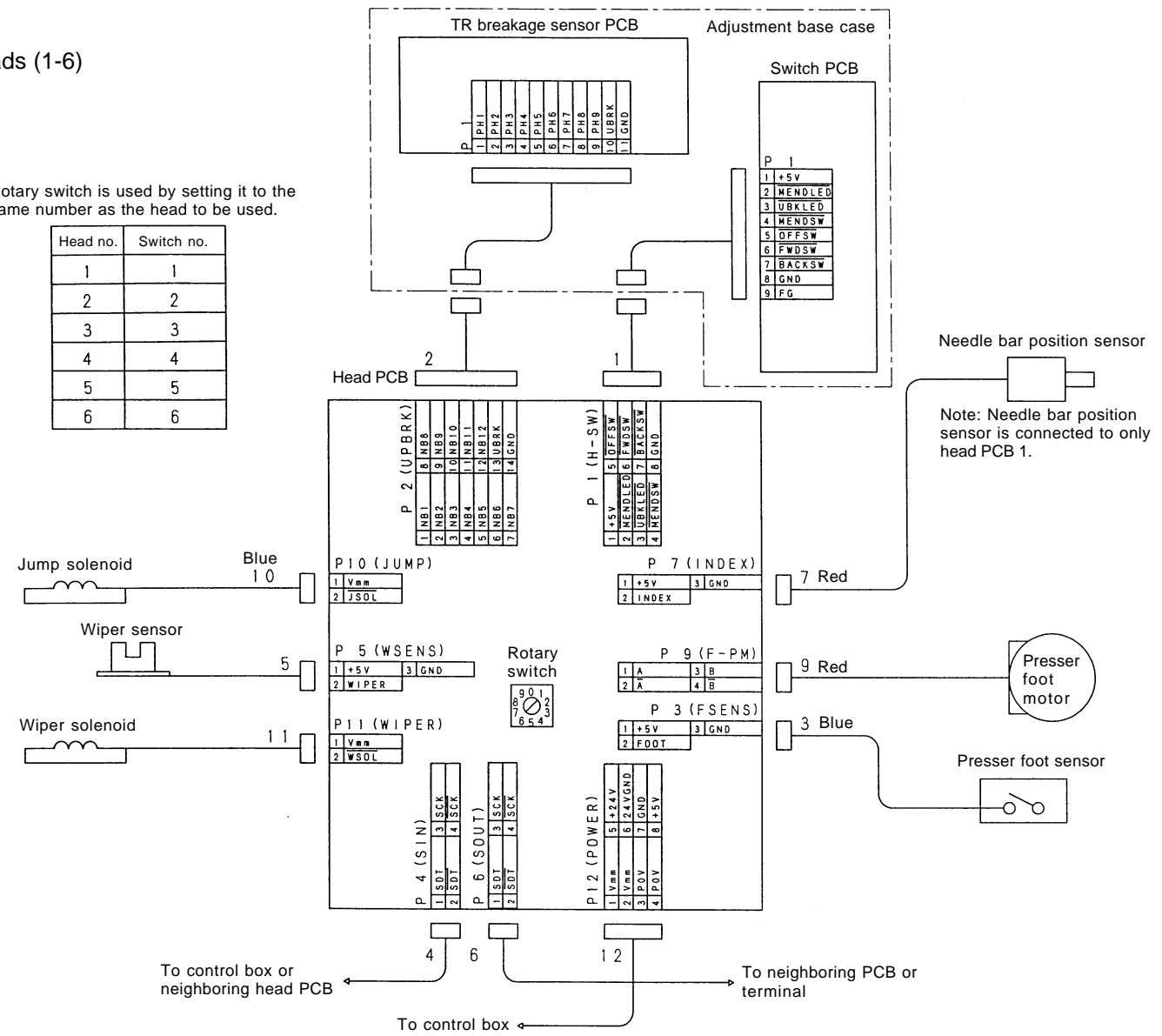

## Power supply base

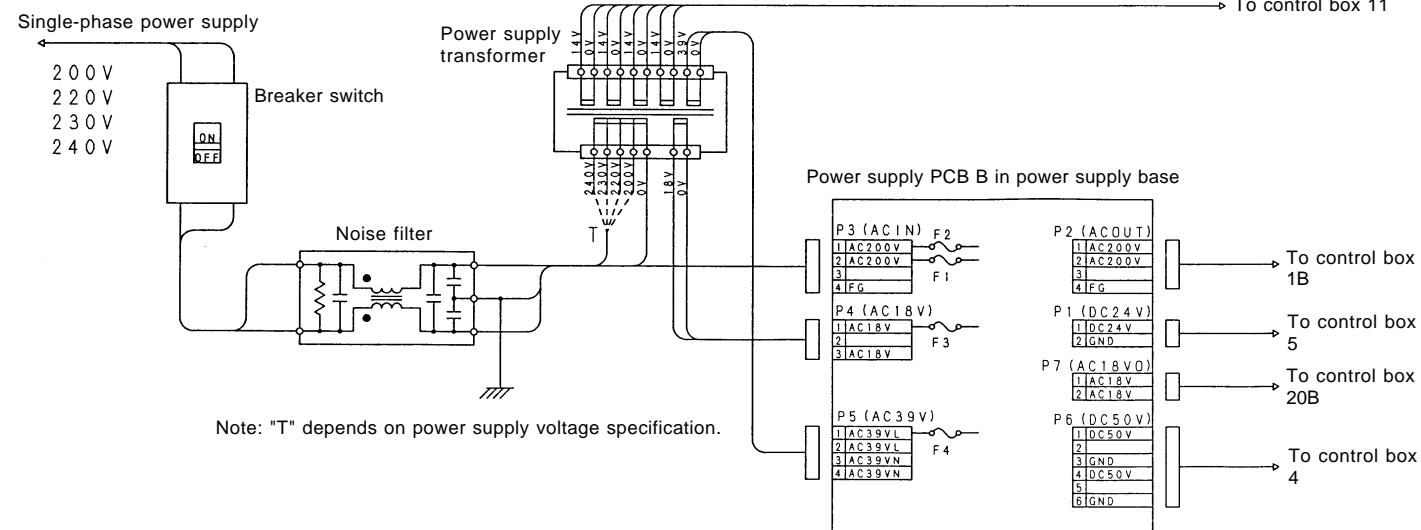

Note: "T" depends on power supply voltage specification.

## Lower shafts (1-6)

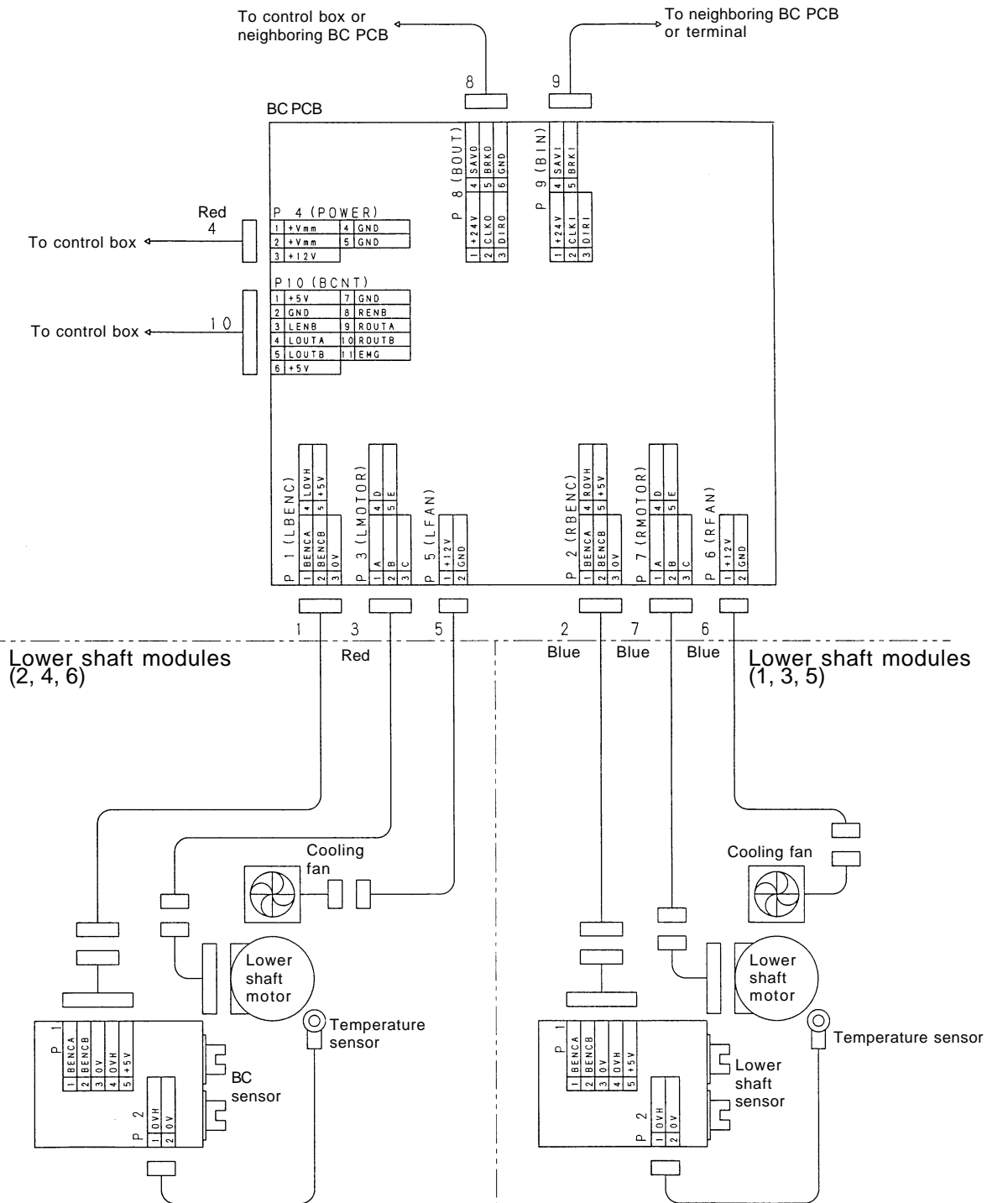

# Heads (1-6) (BES-1260BC)

## Heads (1-6)

Rotary switch is used by setting it to the same number as the head to be used.

Head no.	Switch no.
1	1
2	2
3	3
4	4
5	5
6	6

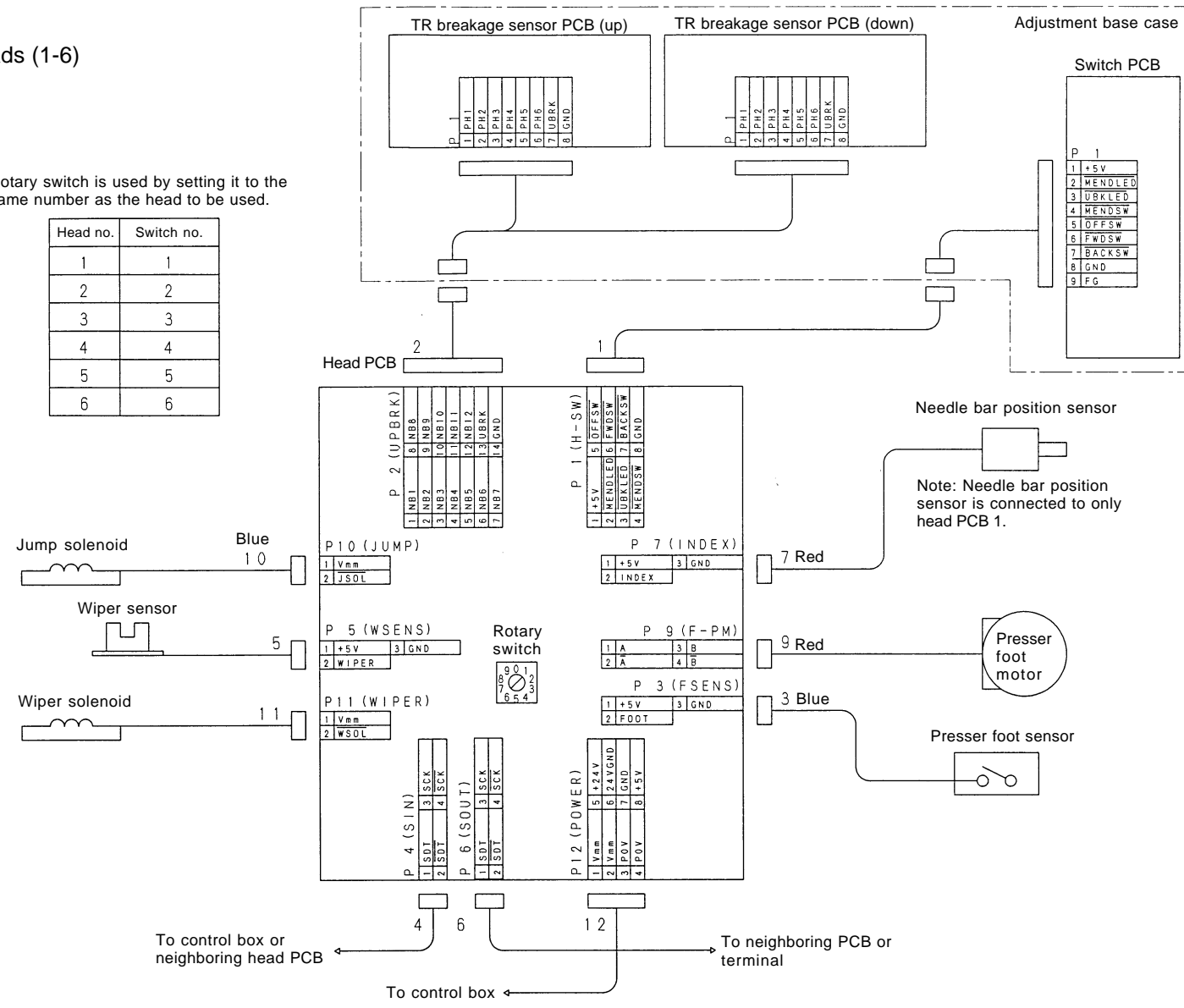

## Power supply base

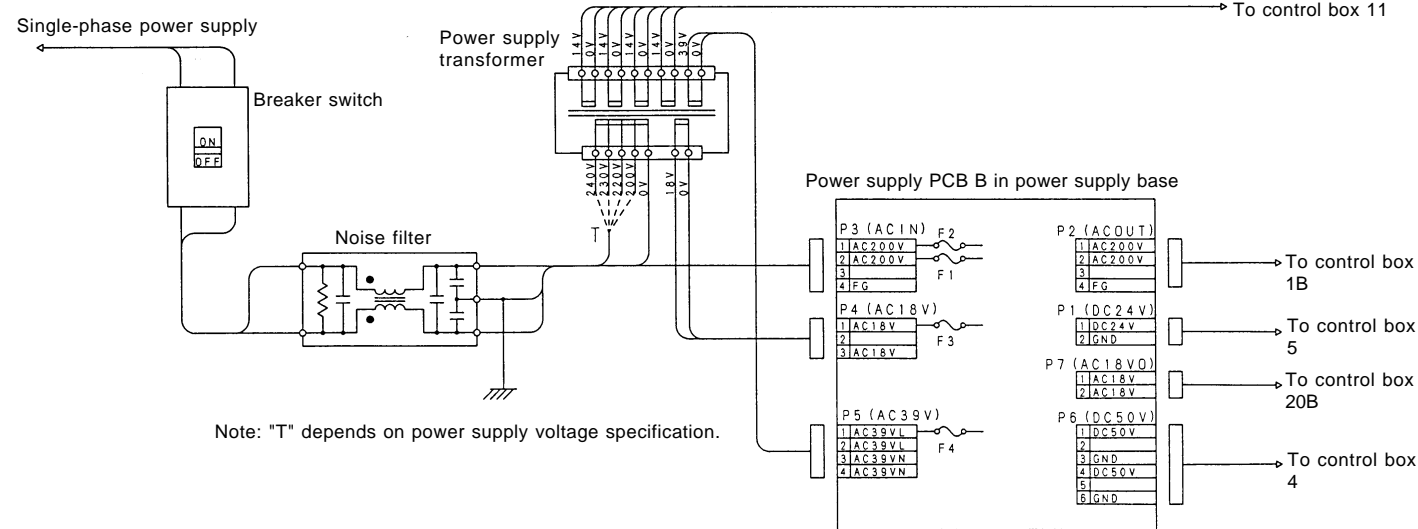

## Lower shafts (1-6)

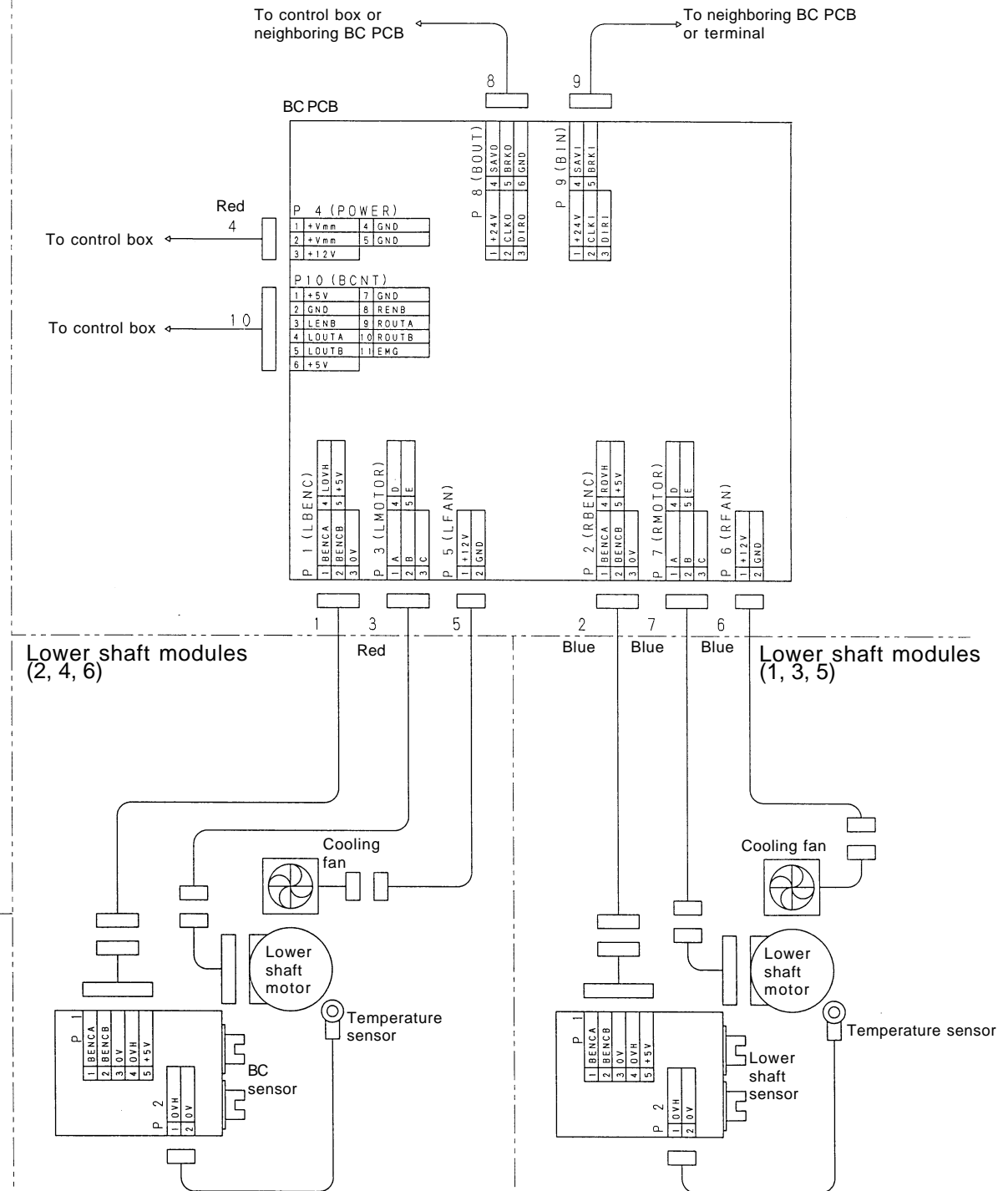

**brother**<sup>®</sup>

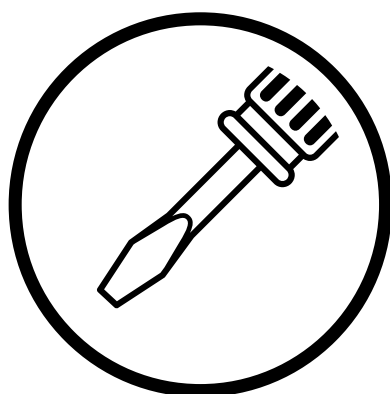

SERVICE MANUAL

**BROTHER INDUSTRIES,LTD. NAGOYA,JAPAN**

---

Printed in Japan

155-960, C60  
I8040742B  
1998.11. (1)