

brother.

COMPACT COMPUTERIZED MONOGRAMMING MACHINE

BAS-47

INSTRUCTION MANUAL

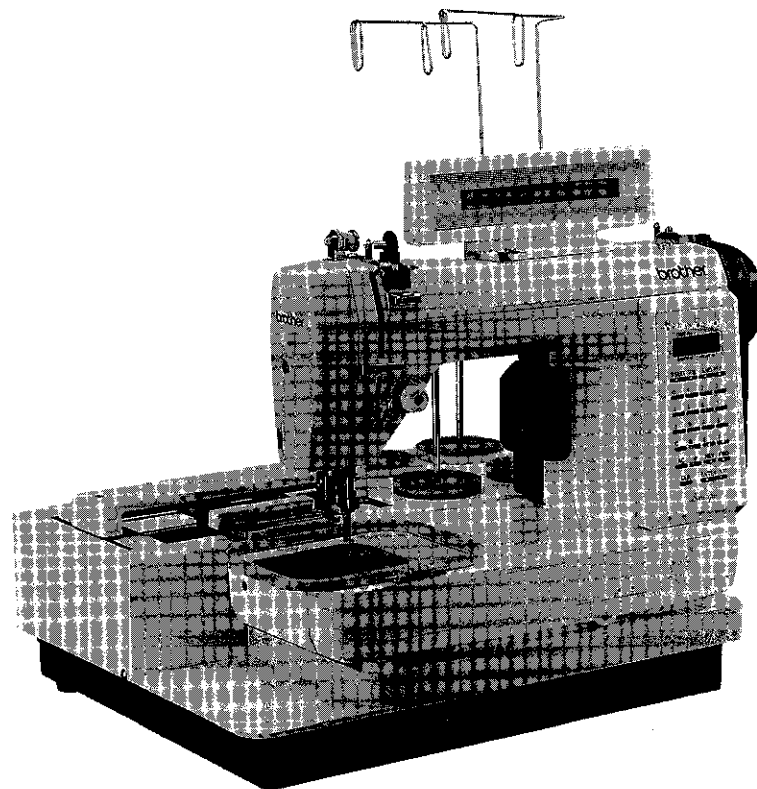

CONTENTS

SPECIFICATIONS	1
SETTING UP	2
1 Part names	2
2 Lubrication	4
3 Replacing the bobbin	5
4 Replacing the needle	5
5 Winding the bobbin thread	6
6 Adjusting the bobbin thread guide	7
7 Threading the needle thread	8
8 Drawing out the bobbin thread	9
9 Installing the embroidery hoop	9
10 Adjusting the presser foot height	10
11 Thread tension	11
12 Cleaning	11
OPERATION PROCEDURE	12
1 Operation panel part names and functions	12
2 DIP switch function	15
FLOW CHART	16
I. PREPARATION	17
Insert the floppy disk	17
II. LETTER SELECTION	18
1 Connecting a keyboard and entering characters	18
2 Alphanumerics (upper and lower case letters, numbers)	20
3 Correcting a letter	21
4 Setting the letter spacing	22
5 Pause	26
Space codes and sewing position	27
6 Carriage return	28
FONT SELECTION	29
Selecting fonts for letters and numbers	29
To embroider the letters	30
Letter monogram specification (optional)	31
III. SEWING	33
1 Sewing	33
2 If "Area over" is displayed	35
3 Test sewing	36
4 To change the sewing start position after test sewing	37
5 Cancel	37

RESEWING 38

- 1 Changing and editing monogram letters 38
- 2 Resewing 38
- 3 Replacing the floppy disk 40

IV. EDITING 41

- 1 Editing letters and numbers 41
- 2 Edit item selection 42
- 3 Setting the sewing area 43
 - Setting sewing area for hoop number 02 43
 - Setting the monogram area 45
- 4 If "Short of area" is displayed 47
- 5 Enlarging or reducing 48
- 6 Thread density and letter width 57
- 7 Arrange 59
- 8 Setting a curved monogram 60
- 9 Rotation 65
- 10 Centering 67
 - Setting the needle start position and sewing position 70
- 11 Editing item confirmation 71
- 12 Setting the sewing speed 73
- 13 Tatami stitching 74
- 14 Storing character data on disk (creating a storage disk) 75
- 15 Reading character data 77

OPTIONAL PARTS 80

- 1 Sub table 80
- 2 Spring 80
- 3 Bobbin thread sensor 81

TROUBLESHOOTING 84

ERROR MESSAGES 86

CHARACTER CODE LIST 87

FLOPPY DISK INPUT CONTENTS LIST 88

Cautions concerning Use

1. Using this product near radios or televisions may cause interference to their reception. If this happens, move the monogramming machine and radio or TV farther apart.
2. The power cord for this product is equipped with a ground terminal. Be sure to ground the machine whenever possible.

SPECIFICATIONS

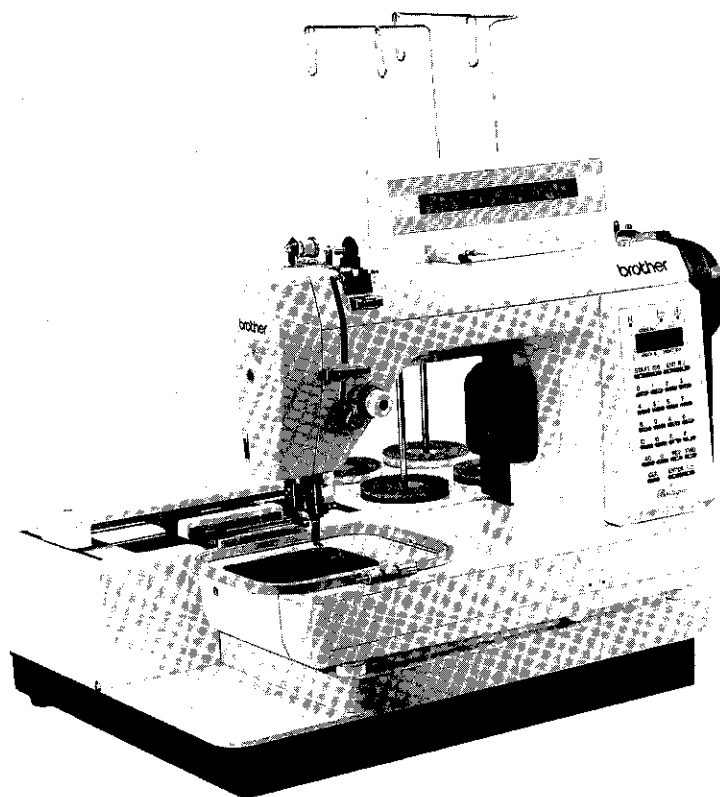

- ☆ Interactive operation makes monogramming names easier than ever for beginners.
- ☆ Designed to be compact. Minimal installation space is required.
- ☆ Company names, club or team names, and other letters sewn can be stored on floppy disk for later use.
- ☆ Twenty-eight styles of lettering are available.
- ☆ Letter size, thread density and letter width, letter alignment, and sewing area can be easily set, and letters can be individually added or deleted for easier editing of the monogram.
- ☆ Optional disks of pattern designs (for sports, animals, flowers, Zodiac signs, design frames) are also available.

Sewing machine model	BAS-47
Application	Monogramming on suits, shirts, sportswear, handkerchiefs, other articles
Maximum sewing speed	1000 spm
Sewing area	120 mm x 100 mm
Stitch length	0.1 - 12.7 mm
Storage medium	3.5" floppy disk
Power supply	Single phase, 120, 220, 240 V
Dimensions	400 mm (D) x 520 mm (W) x 460 mm (H)
Weight	30 kg

SETTING UP

Part names

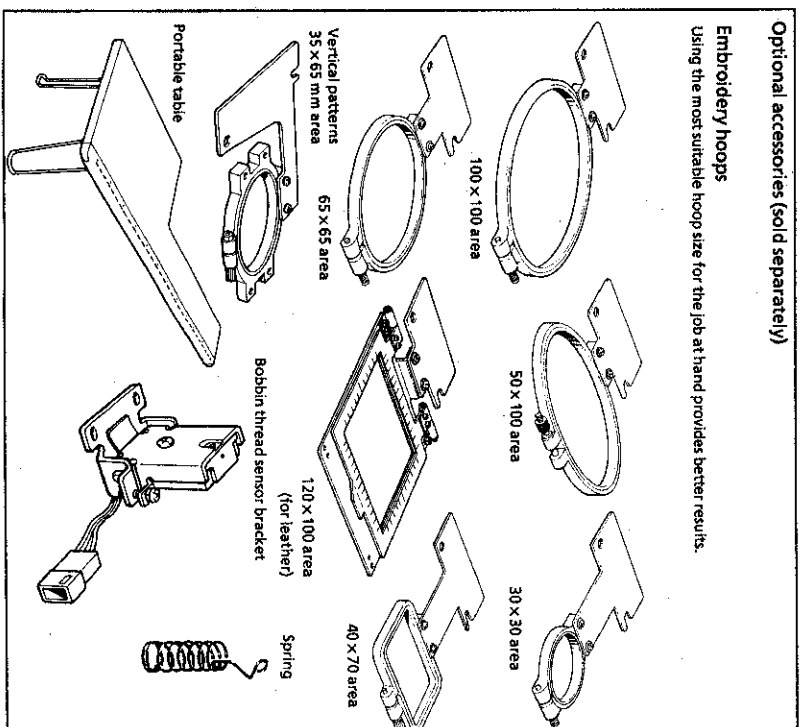
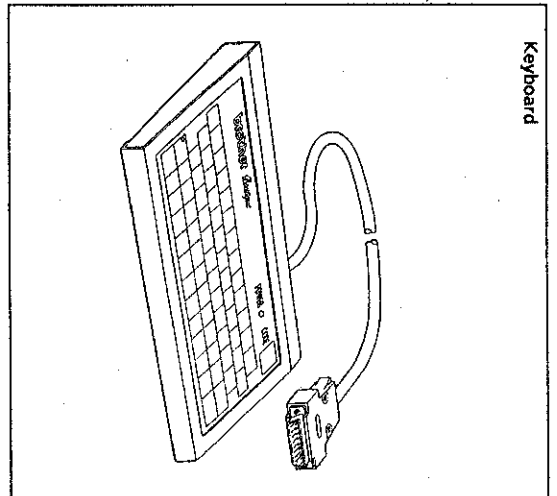
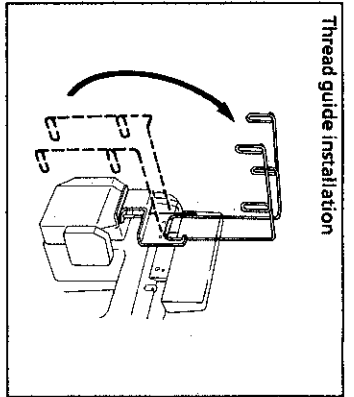
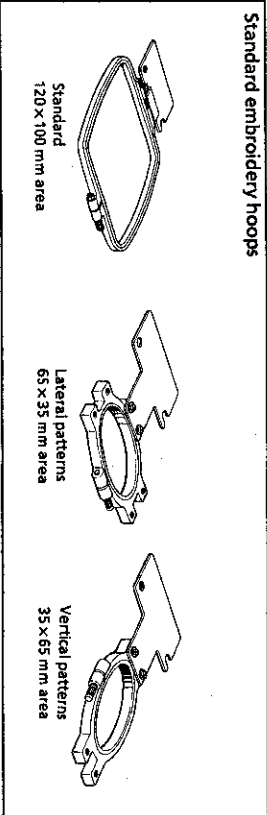
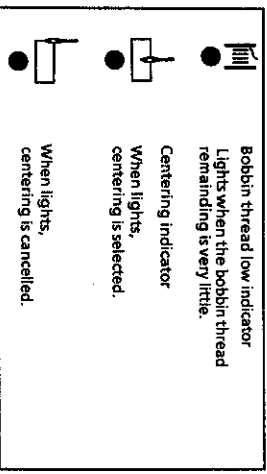
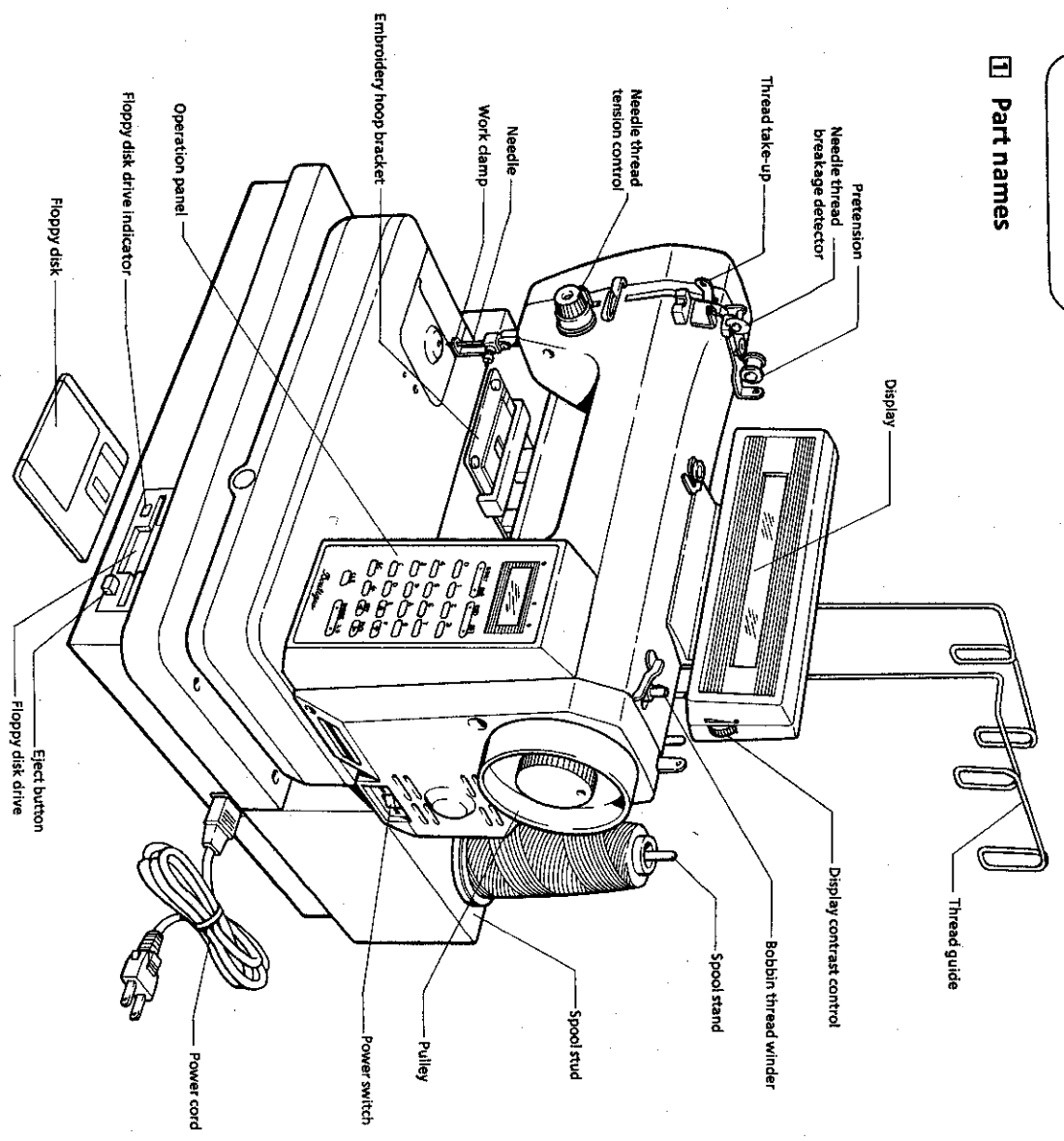

2 Lubrication

Be sure to use Brother-specified sewing machine oil for lubrication. Adding too much lubrication oil may cause the oil to get on the material; be careful not to overfill the reservoir.

- Add 2-3 drops of oil at each position indicated by an arrow. If there is oil around the lubrication position, wipe it off with a cloth.
- Lubrication is necessary at least once a month. (If the machine is used for several hours every day, lubricate daily.)
- Lubricate the machine after using it and then be sure to run the machine without thread or material.

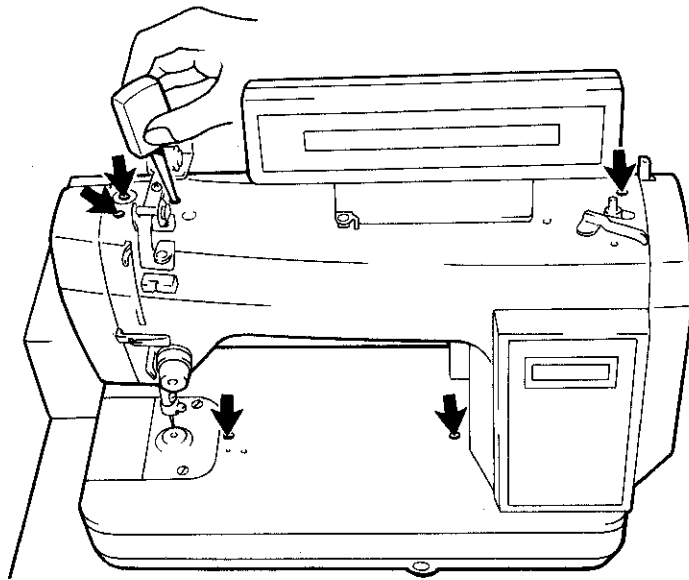

Open the needle plate side cover ①.
Remove the bobbin case ②.

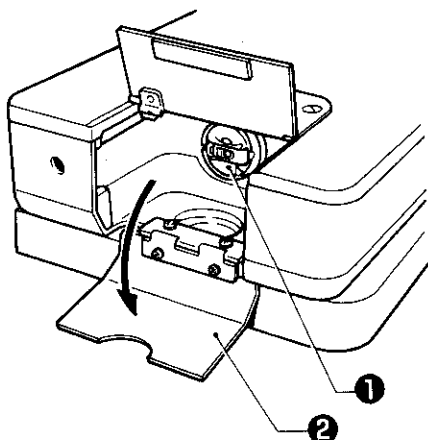

Add a drop of oil to the rotary hook.
DO NOT lubricate anywhere else.

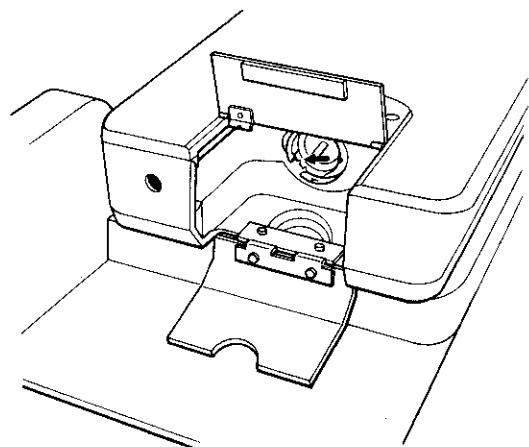

3 Replacing the bobbin

1. Remove the bobbin case.

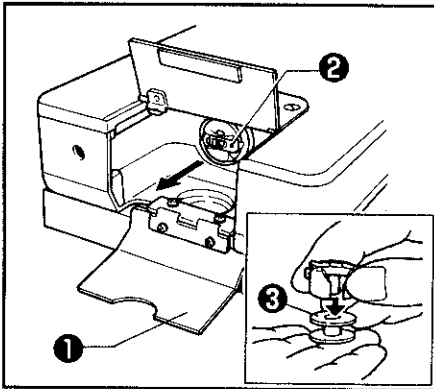

- (1) Open the needle plate side cover ①.
- (2) Pull out latch ② and remove the bobbin case.
- (3) Return the latch ② to the original position and remove the bobbin ③.

2. Replace the bobbin.

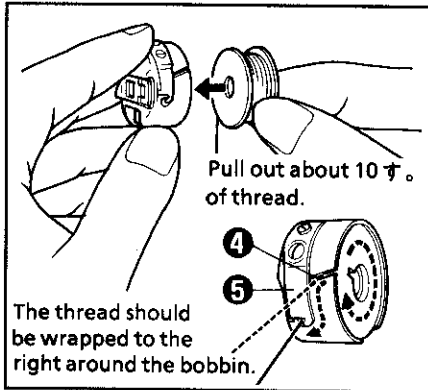

- (1) Close the bobbin case handle.
- (2) Pass the thread through the notch ④ and under the tension spring ⑤.

3. Replace the bobbin case.

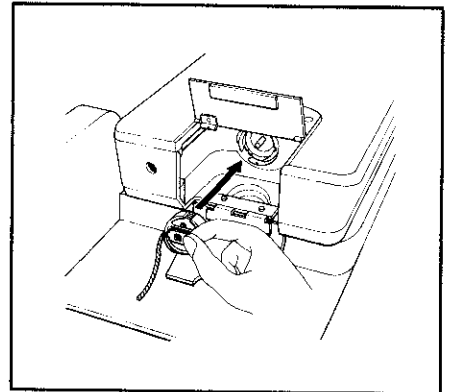

- (1) Hold the latch ② and insert the bobbin case into the rotary hook assembly.
- (2) Close the cover ①.

NOTE: The bobbin spring may not function properly, resulting in bobbin thread breakage, if thread ends and dust collect inside the bobbin case. Be sure to keep the bobbin case and the shuttle body clean at all times.

4 Replacing the needle

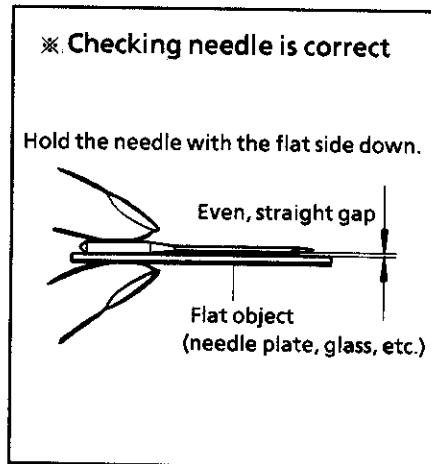
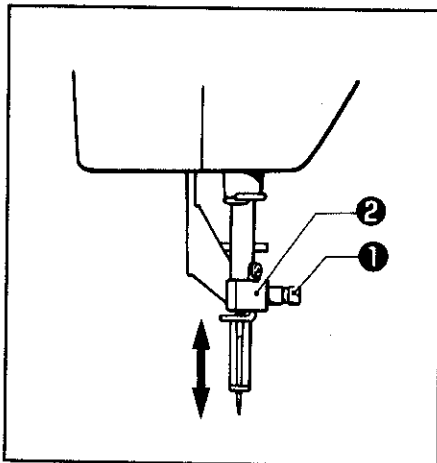

- (1) Loosen the screw ①, and remove the needle.
 - (2) Insert a new needle with its long groove facing the left, until it makes contact with the stopper ②. Tighten the screw using a coin or a similar shaped tool.
- * Hold the flat side of the needle against a flat object to make sure that the gap is even along the length of the needle and the needle is straight.

NOTE: Using an incorrect needle may cause stitches to be skipped, thread breakage, or damage to the material. Check the needle condition occasionally.

Materials and needle selection

Fabric type	Needle size	Embroidery thread
Denim, leather	DB x K5 #11 - #16	#75 - #150 denier
Handkerchief, shirt, towel	DB x K5 #9 - #11	

* Better results can be obtained by using a heavy-duty needle (#11 - #14) when sewing with special threads (gold, silver, or other ramie yarns).

5 Winding the bobbin thread

1. Set the bobbin.

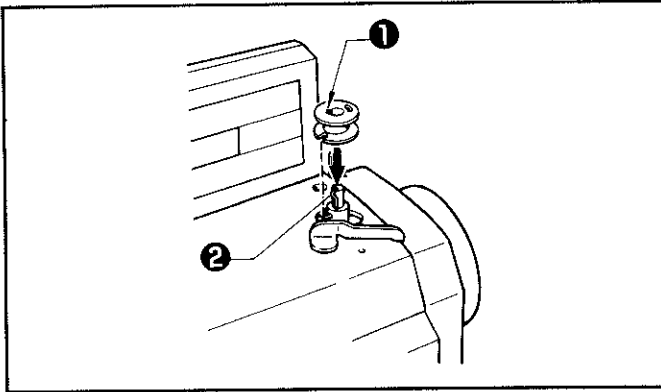

Set the bobbin on the bobbin winder, and push the bobbin presser toward the bobbin.

* Fit the bobbin winder spindle spring ① firmly in the notch ②.

2. Set the bobbin thread.

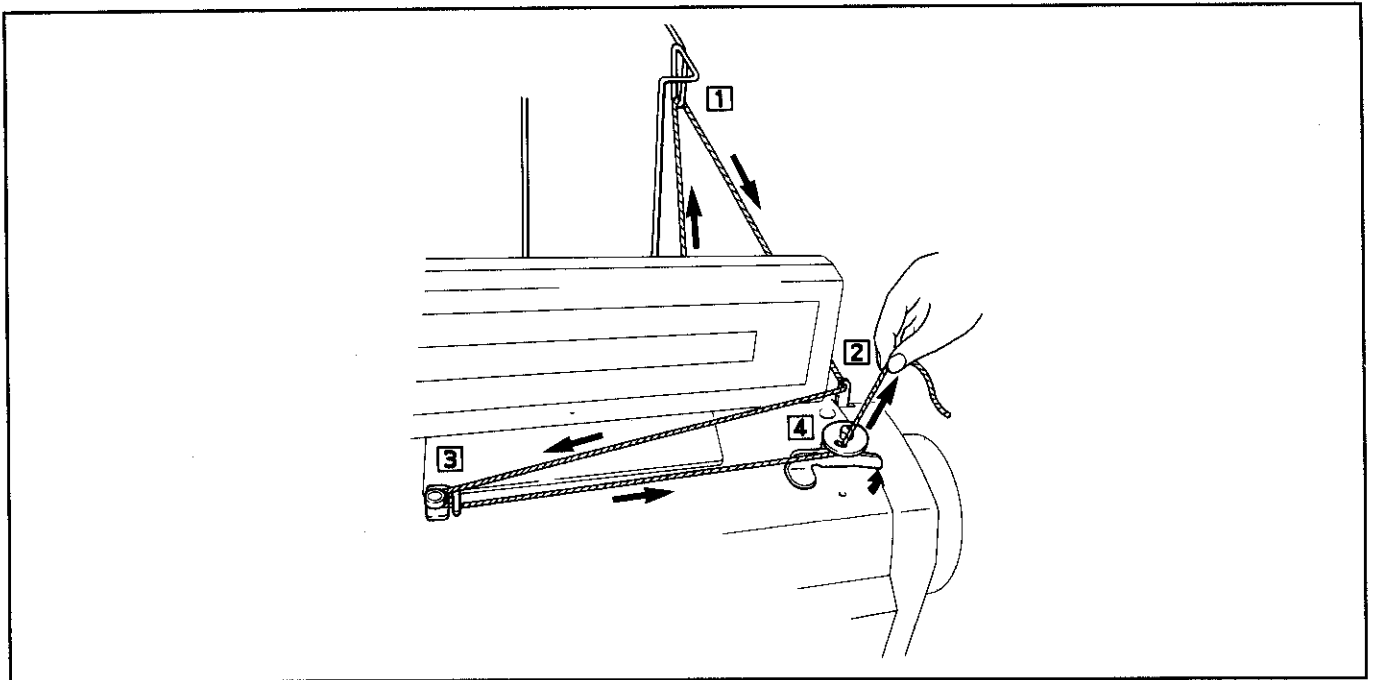

3. Turn the power switch on.

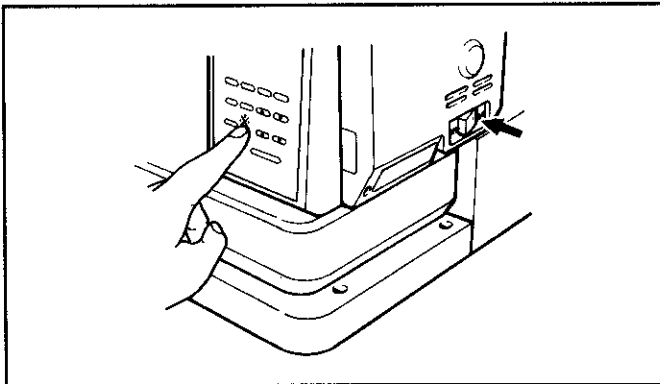

Press the confirm/test <*> key, and turn the power switch on. [Pull out upper thr. from needle], and [Attention moving] will be alternately displayed.

4. Fill the bobbin.

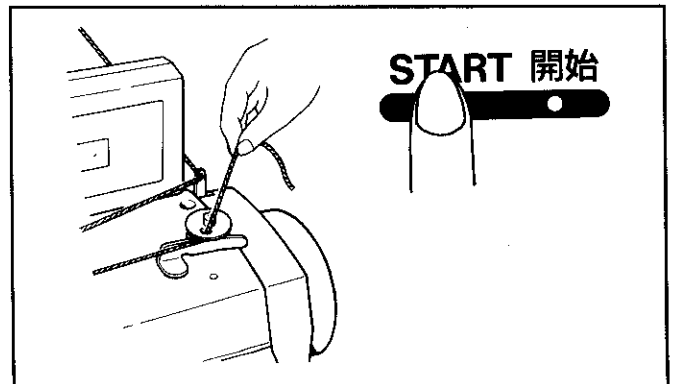

Pass the thread through the hole in the bobbin. Hold the end of the thread and press <START>.

5. Bobbin is full.

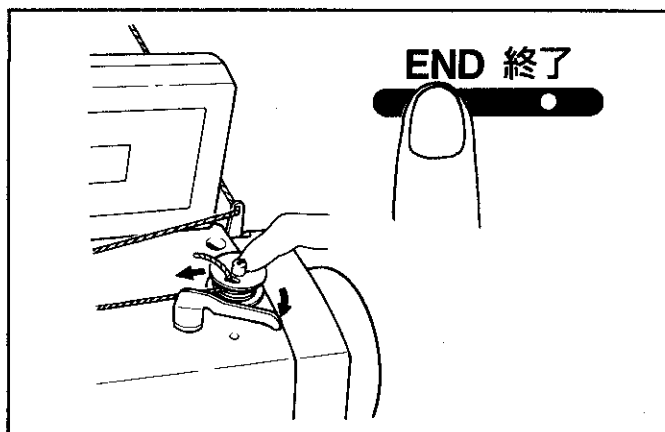

The bobbin will stop when it is full. Press <END>, and cut the thread.

6 Adjusting the bobbin thread guide

If the bobbin thread is not wound on the bobbin evenly, it may cause an incorrect bobbin thread tension.

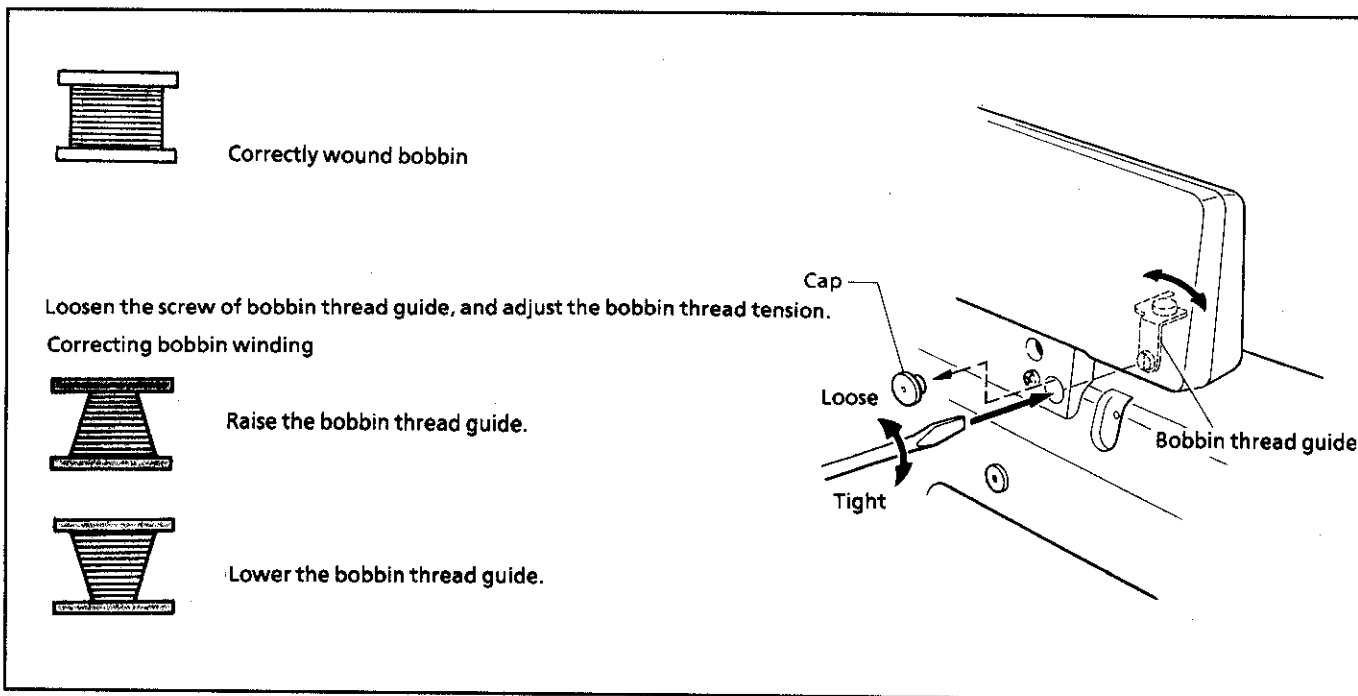

7 Threading the needle thread

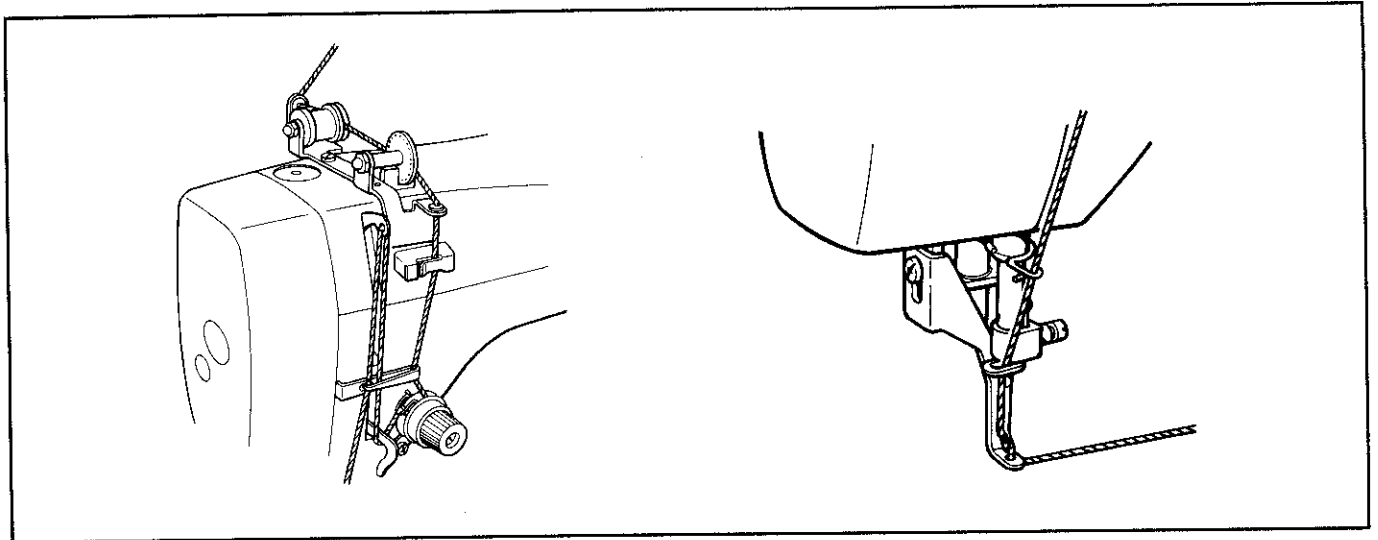

1. Thread the thread guide.

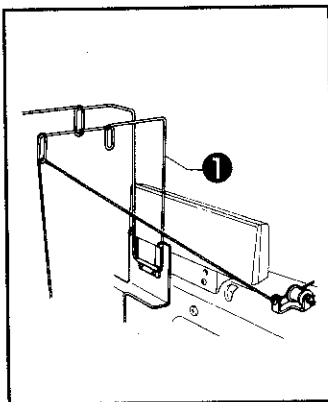

Pass the thread from the outside to the inside of the thread guide ①.

2. Thread the pretension.

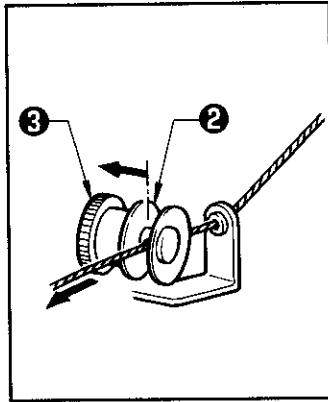

Press the pretension ② to open it, and thread the thread through the hole. Turn screw ③ so that there is just the slightest tension applied to the thread (approx. 5 g).

3. Thread the thread guide for the needle thread breakage detector.

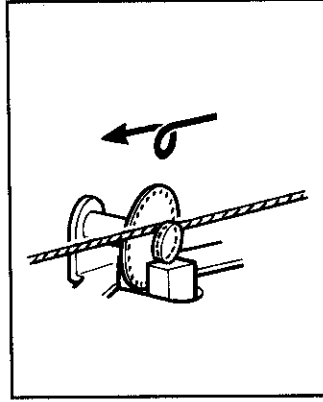

Wrap the thread around the thread guide 2 - 3 times so that the thread is as shown in the figure.

4. Thread the thread guide for the thread tension regulator.

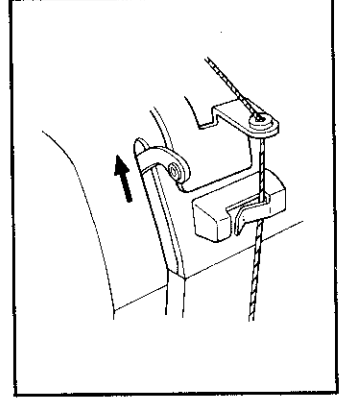

Turn the pulley to raise the thread take-up lever to its upper position. Thread in order shown above.

5. Thread the thread tension bracket.

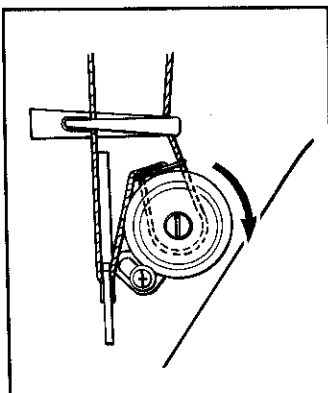

6. Thread the thread take-up.

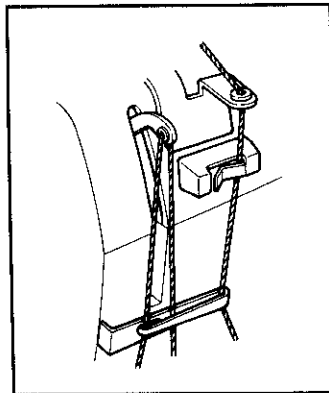

7. Thread the thread guide and needle.

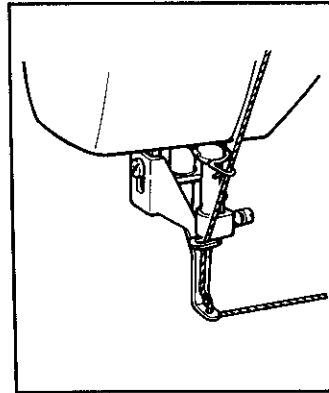

8 Drawing out the bobbin thread

1. Turn the pulley.

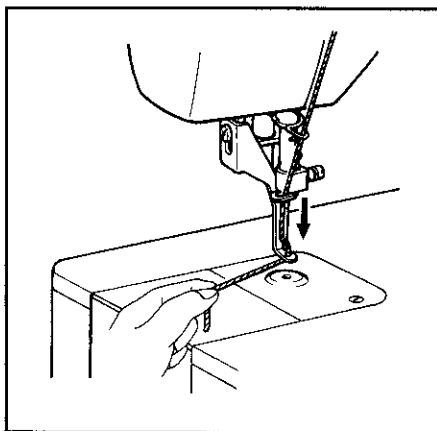

Hold the needle thread gently and turn the pulley.

2. Pull the needle thread up.

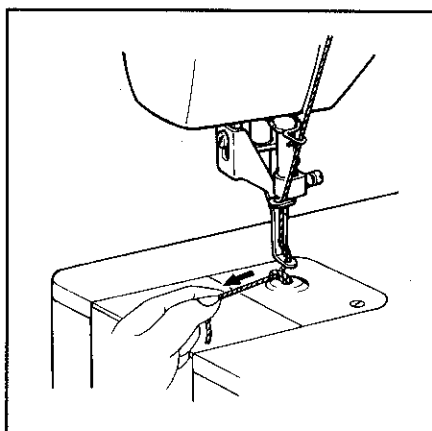

Pull the needle thread to draw the bobbin thread out.

3. Pull out the bobbin thread.

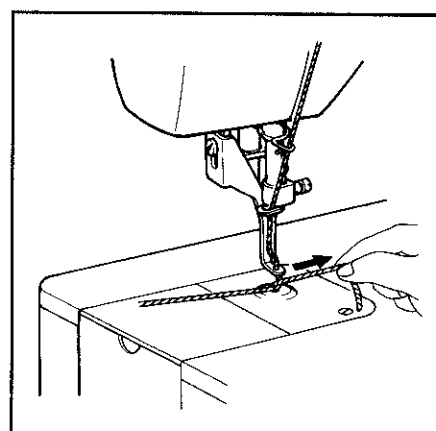

Pull both the needle and bobbin threads out about 40 mm.

* To pull the bobbin thread out on top of the material, press <START> when sewing, and press any key before the embroidery hoop starts moving. The machine will stop. Pull the bobbin thread out as described above. The machine will start sewing when <START> is pressed. Press any key after sewing about 5 stitches. After the machine stops, cut the bobbin thread ends. Press <START> to continue sewing.

9 Installing the embroidery hoop

1. Fit the material into the embroidery hoop.

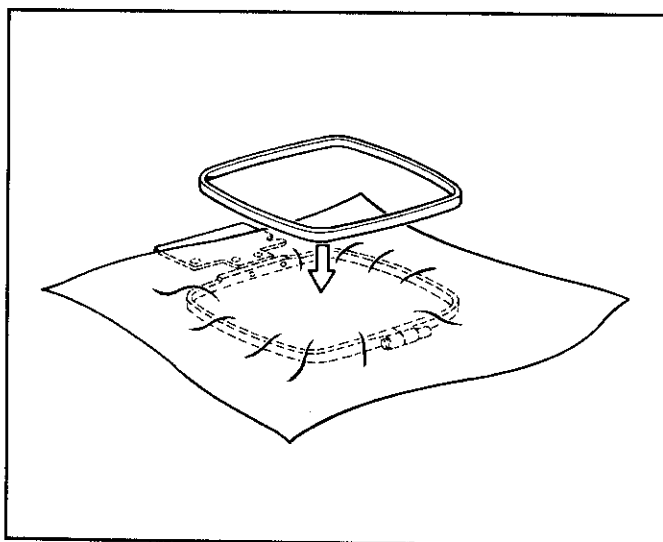

A poor fitting embroidery hoop may cause skipped stitches, thread breakage, puckering, or other problems.

2. Install the embroidery hoop.

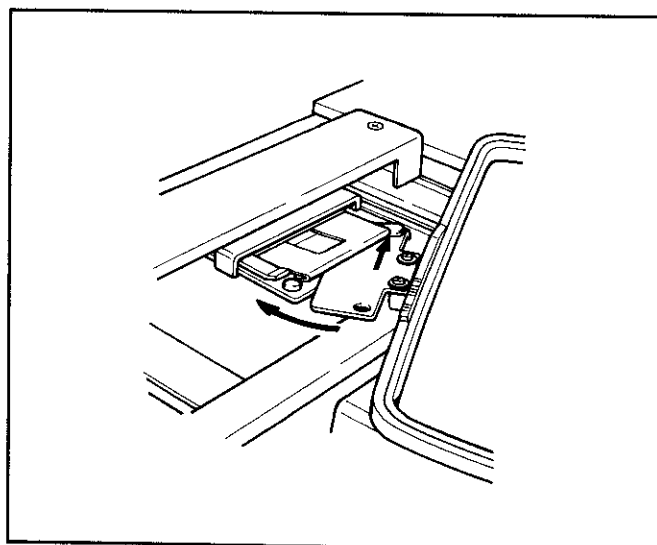

Install the embroidery hoop firmly as shown above.

10 Adjusting the presser foot height

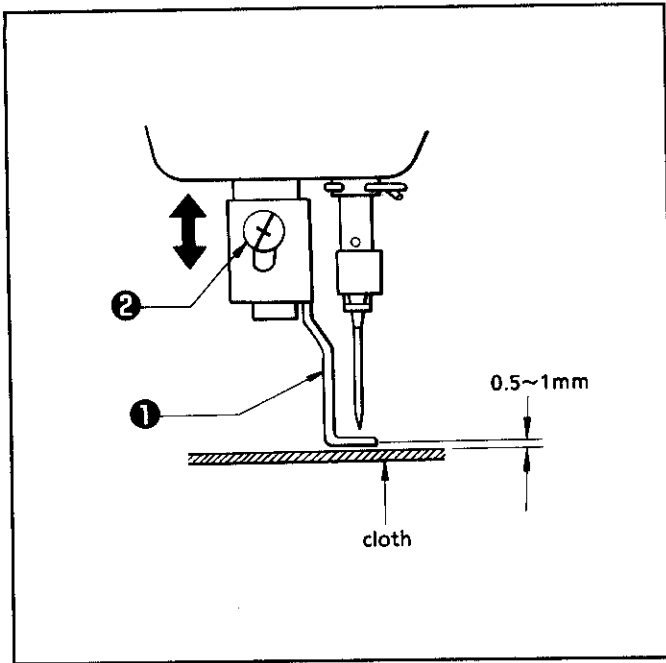

Turn the pulley to lower the presser foot ❶ to its lowest position. Loosen the screw ❷. Adjust the presser foot ❶ by moving it up or down so that there is a 0.5 - 1 mm clearance between the top of the material and the bottom of the presser foot ❶.

11 Thread tension

Needle thread tension

If the thread tension is not adjusted properly, irregular stitching, material puckering, or thread breakage may occur.

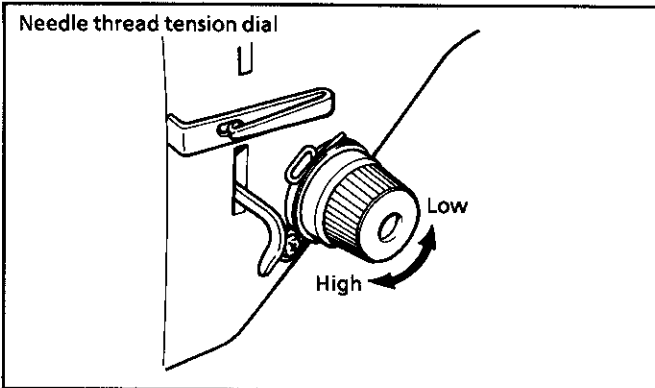

If the needle thread tension is too high, turn the dial clockwise.
If the needle thread tension is too low, turn the dial counterclockwise.

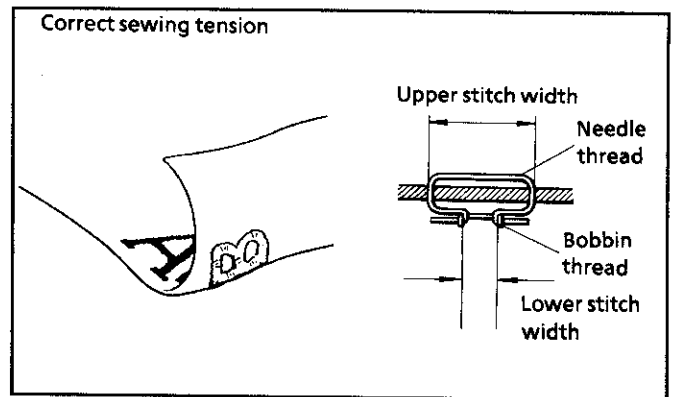

Adjust the tension dial so that the needle thread is pulled to the back of the material, and the bottom stitch width is about 1/3 that of the upper stitch width.

Bobbin thread tension

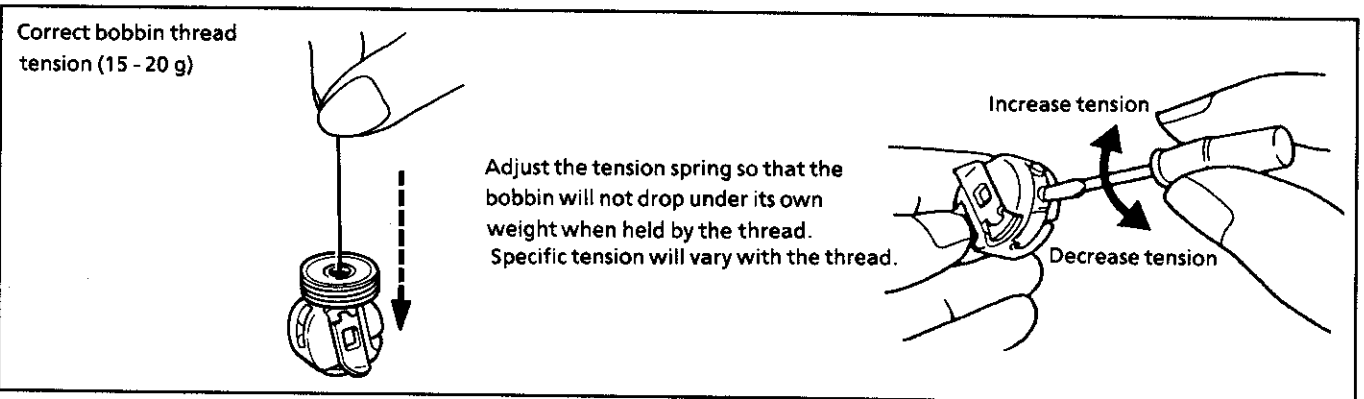

12 Cleaning

A dirty or clogged machine may result in equipment failure. Be sure to keep the machine clean at all times.

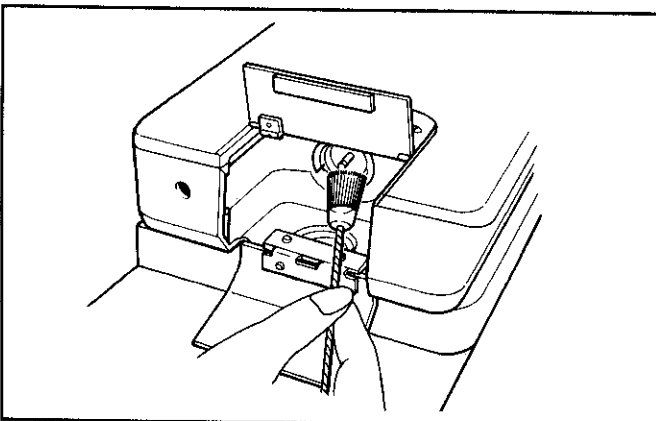

Always clean

If the machine is only slightly dirty or dusty, wipe clean with a soft, dry cloth. If necessary, wipe with a cloth dampened with a neutral detergent or hot water, and then wipe the detergent off cleanly with a cloth dampened with hot or cold water.

Do not clean with benzene, thinner, or other volatile solvents.

When cleaning the rotary hook and its associated parts, add 1 - 2 drops of oil to the rotary hook mechanism. After lubrication, try sewing.

Refer to page 4, "Lubrication."

Avoid high temperatures

Keep the machine away from hot stoves, irons, and similar heat sources. Store the machine out of direct sunlight.

OPERATION PROCEDURE

1 Operation panel part names and functions

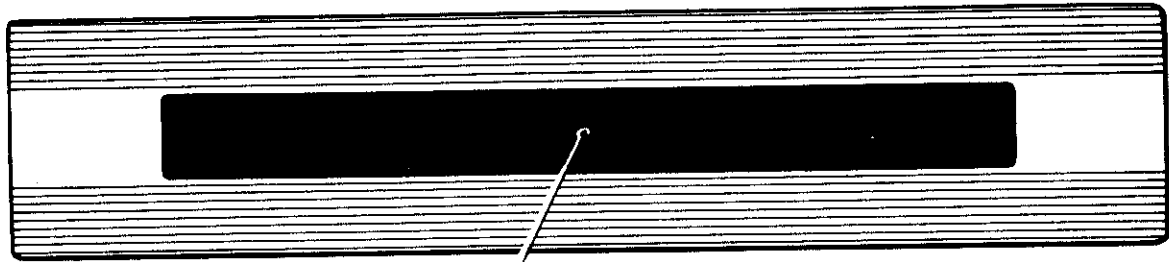

Display

Display

The display shows messages, error codes, and other prompts, the selected monogram letters, editing menus, and other items on a 30 character (8×8 dots) display.

Display contrast control

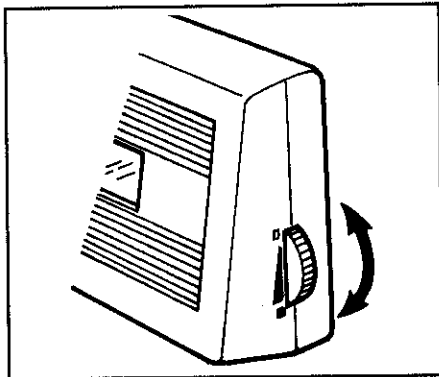

Used to make it easier to read the letters on the display.

* Adjust the display after turning the power switch on. [Attention moving] will be displayed, followed by [No Floppy Disk].

LED indicators

The text (2 letters or numbers) entered with the character code, and the enlargement/reduction size ratio (letter width and height) are displayed.

* The letters A, E, and F will always be displayed in upper case, and B, C, and D will always be displayed in lower case.

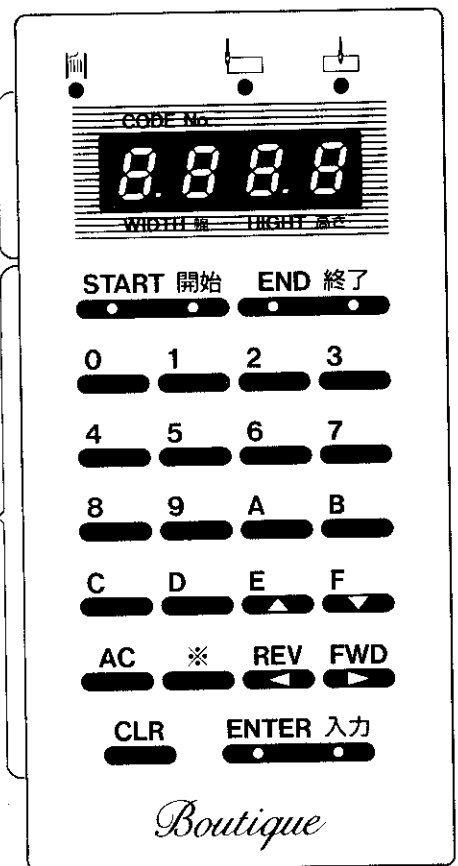

Keyboard

START key

START 開始



Used to start sewing after selecting the monogram letters, and to select the sewing mode.

Used for editing after setting the font number.

END key

END 終了



Used to edit after selecting the letters.

Used to sew after setting the font number or editing.

Used to cancel a change in the sewing pattern, test operation, or changes in floppy disk settings.

Used to terminate the enlargement and reduction ratio mode.

Number keys



Used to enter the character code.

Used to select the editing task number and to enter edit task settings.

Used to select letter enlargement or reduction (ratio and dimensions).

Letter keys



Used to enter character codes.

(E and F are also used as jog keys.)

Jog keys



Used to move the needle position in the direction of the arrow on the key.

REV. and FWD. are used to move the cursor position on the display. Also used to move the needle position one stitch at a time forward or back when resewing after thread breakage.

The jog keys can be used when editing with [1. Area] and [Designate point on upper left] and [Designate point on lower right] are alternately displayed, or when the needle start position is set before starting to sew and [Move needle to start point > ent] is displayed or [Move needle to start point > ent] and [Area over] are alternately displayed, or [Move needle to start point > ent] and [Sewing > start, Trace > *, Quit > end] are alternately displayed.



CLR key



Used to clear the letter over the cursor in the display. Edited contents will remain unchanged.

Used to clear the LED character code or to reset the ratio (letter width and height) to the standard (default) value in order to re-enable entry.

All clear key



Used to clear all letters on the display.

All edit contents will be automatically reset to the standard default values when <AC> is used.

Used to reset all edited contents to the standard values.

ENTER/FIX key



Used to convert character codes to letters.

Used when entering area, letter size ratio, font number, thread density and letter width, and the needle start point settings.

Confirm/test key



Used when winding the bobbin thread.

Used to confirm edit task contents.

Used when testing the sewing position of selected letters.

Used to determine why hollow letters are displayed.

Bobbin thread remaining indicator



— This means that very little bobbin thread remains.

Centering indicator

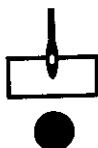

— This means that the needle start point is in the center of characters or pattern.

Centering canceled indicator

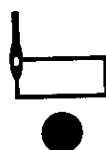

— This means that the needle start point is to the left of characters or pattern.

2 DIP switch function

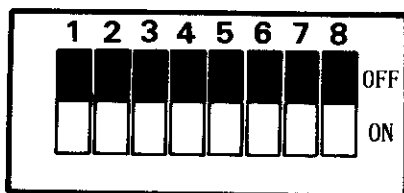
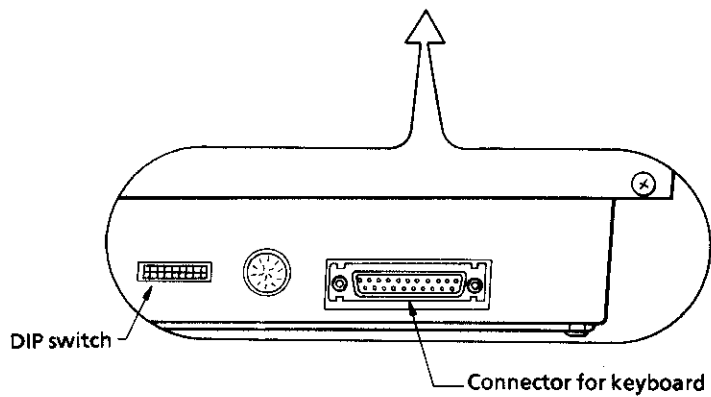
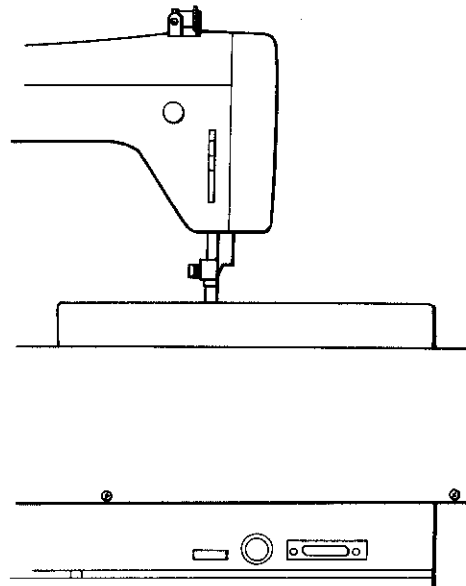

• All DIP switches are set to OFF before delivery.

DIP switch function		
SW	OFF	ON
1	Needle thread breakage detector activated.	Needle thread breakage detector deactivated.

I . PREPARATION

Inserting the floppy disk

Turn the power switch on.

Attention moving

No Floppy Disk

Insert the floppy disk.

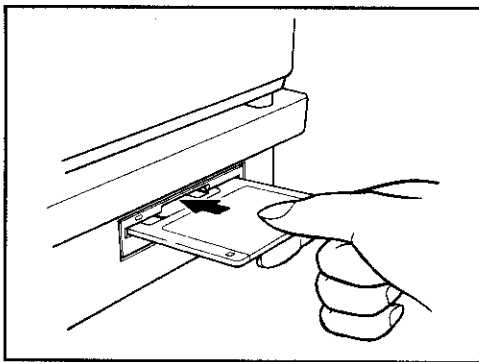

Reading now

Input Letter code.

II . LETTER SELECTION

- * 1. If the power switch is turned on when the needle is lowered, **Turn pulley** will be displayed and an alarm will sound. After turning the pulley, **Press start key** and **Attention moving** will be alternately displayed, and the alarm will continue to sound. Press <START>.
- * 2. If the power switch is turned on after the Alphabet disk is inserted, **Reading now** will be displayed, followed by **Input Letter code**.
- * 3. If the power switch is turned on after the memory disk is inserted, or if the memory disk is inserted first after the power switch is turned on, **Replace with Alphabet F. D.** will be displayed. Insert the Alphabet disk.

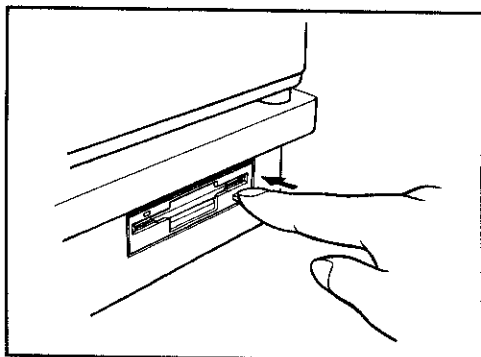

1. The display will come on when the power switch is turned on.

An alarm will beep four times, and the needle will be positioned at the center of the embroidery hoop.

2. Insert the Alphabet floppy disk.

* 1. It will not be possible to read or write to disk, and drive or disk problems may result if the disk is not properly inserted.

* 2. Floppy disks are a magnetic storage medium. The data on the disk can be easily damaged by magnetism, and the disks should therefore be kept away from magnets, televisions, telephones, and other products which may produce a magnetic field.

Floppy disks should not be brought near the slide plate since it has a magnet on its back.

Displayed when the floppy disk drive indicator goes out.

* **Input Letter code** will be displayed if in the default settings mode. If the letters have been set, the entered letters will be displayed.

Removing the disk

Press the eject button. The disk will pop out, and **No Floppy Disk** will be displayed. Do not try to eject the disk while the floppy disk drive indicator is on.

II. LETTER SELECTION

1 Connecting a keyboard and entering characters

Characters can be entered using a keyboard, to the sewing machine. Note that there are some keys which are only operable on the sewing machine operating panel.

A. Connecting a keyboard

1. Keyboard selector

Set the keyboard selector (1) to the keyboard (A or B) used.

[For German, Finnish, Norwegian, and Swedish]

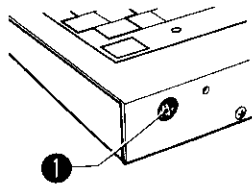

Keyboard A

[For French, Spanish, and Italian]

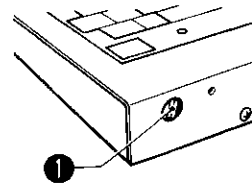

Keyboard B

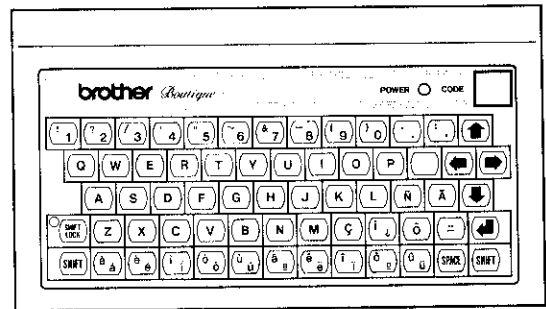
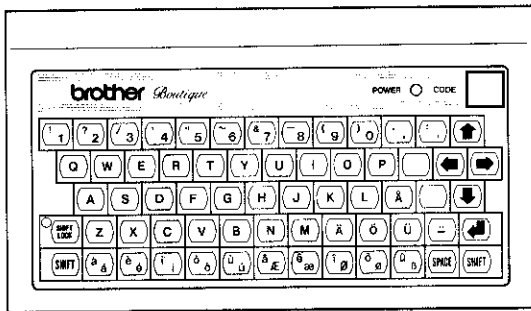

2. Connecting the keyboard to the machine

Turn the power switch on the sewing machine off.

NOTE: Do not turn the power switch off until the floppy disk drive indicator goes out.

See the figures below.

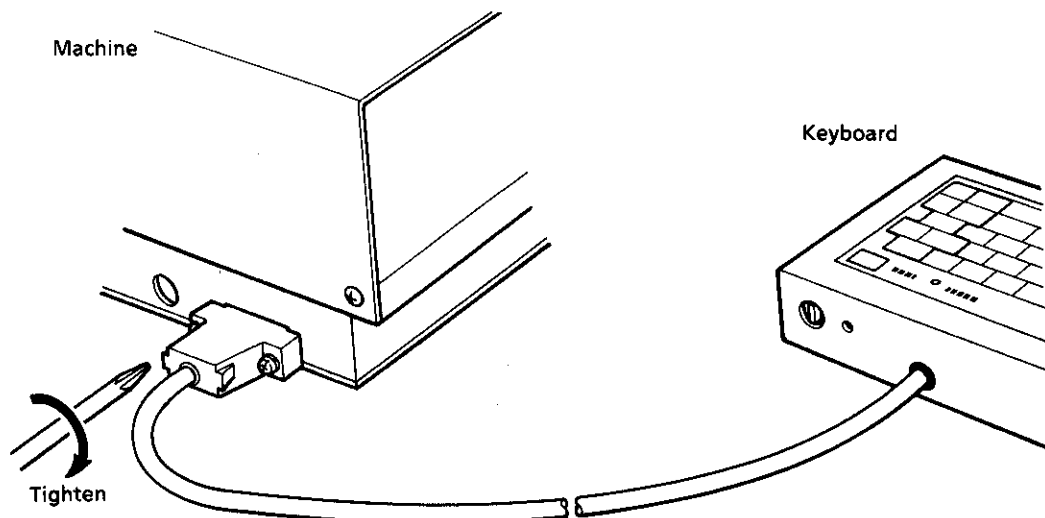

B. Entering letters

Letters can be entered from the keyboard to the machine only when the machine is in the character entry mode.

Power switch is ON.

See page 17. Insert the floppy disk.

Input Letter code.

Characters can now be entered using the keyboard. Those letters shaded in the figure below can be used.

After ending character entry from the keyboard.

After entering the letters, press <START> to proceed immediately to font selection and sewing, or press <END> to proceed to font selection and editing.

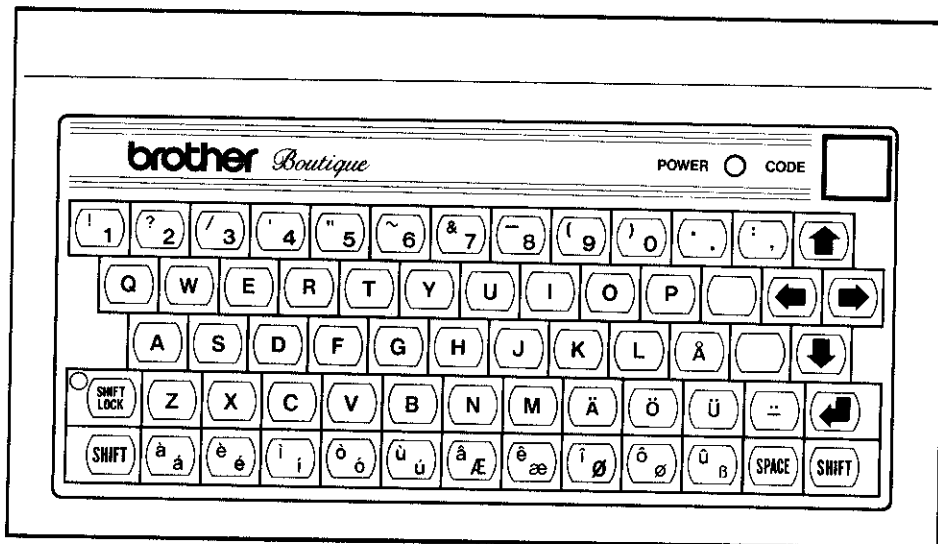

Capitals, symbols, and other characters in the upper left corner of each key can be entered using the SHIFT key. Lower case letters, numbers, and other characters in the lower right corner of each key can be entered normally.

Notes

- Characters cannot be entered using the keyboard unless the machine is in the character entry mode.
- A maximum of 30 characters can be displayed.

2 Alphanumerics (upper and lower case letters, numbers)

There are 28 fonts both upper and lower case, and numbers which can be selected for sewing. Enter the letters and numbers to be embroidered using the keyboard.

Example 1 Enter the letters AB to be monogrammed.

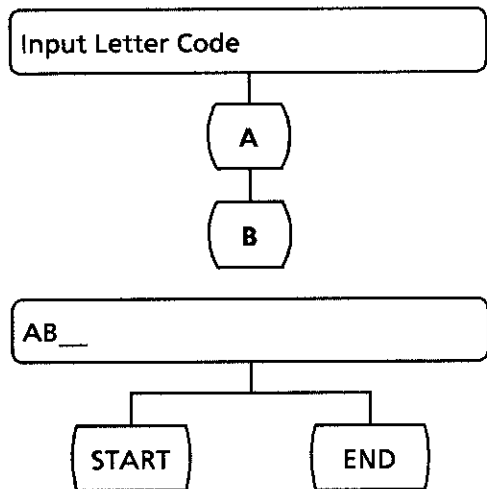

1. Press <SHIFT LOCK>.
2. Type <A> and on the keyboard.

[AB] will appear in the display.

3. After entering the letters, press <START> to proceed immediately to font selection and sewing, or press <END> to proceed to font selection and editing. <START> and <END> switches are mounted on the panel of the machine.

Refer to the standard table for alphanumeric codes.

- * 1. If hollow letters are displayed, move the cursor on the hollow character, and press <CLR> to delete the entry. Either there is no data entered for those letters, or there is a disk error. Move the cursor to the hollow letter, and press <*>. The cause of the problem will be shown.
- * 2. A maximum of 30 standard size characters can be displayed at one time.

NOTE:

If you start sewing using data starting with ←, ↑, ↓, ←, →, incorrect positioning will be performed; please make sure data is correct before starting.

3 Correcting a letter

Input characters can be changed in the text entry mode.

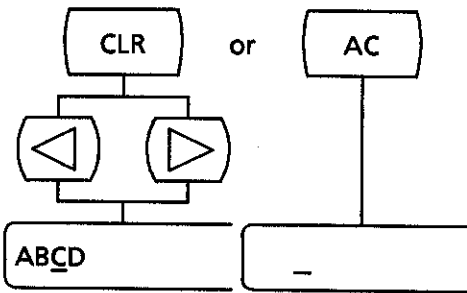

1. Press <CLR> or <AC>. To clear a character with <CLR>, use the jog keys to bring the cursor under the character to be deleted, and then press <CLR>. All characters displayed will be deleted when <AC> is pressed. Re-enter desired characters. All settings other than monogram area setting will be reset to the default settings when <AC> is pressed.

Input characters can be changed in the text entry mode.

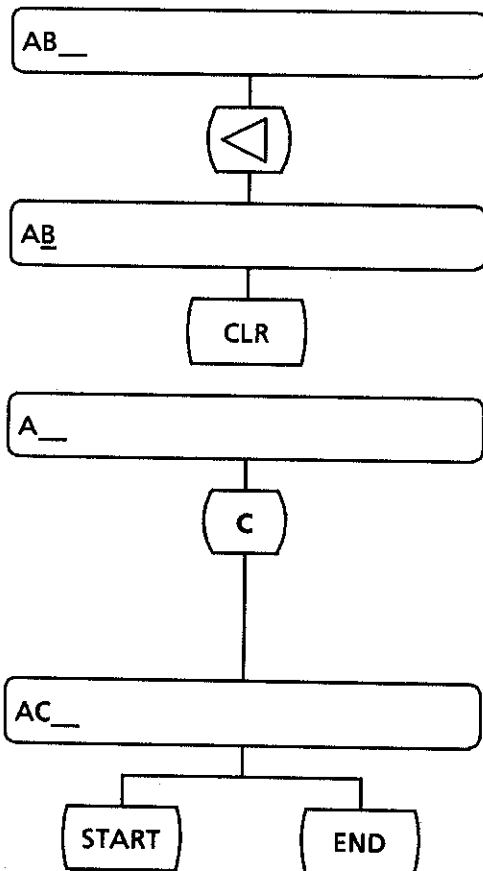

Ex. Change AB to AC

1. Press the jog key <<>. The cursor will move under the B.
2. Press <CLR>. The B over the cursor will be deleted.
* Pressing <AC> will delete all displayed letters.
3. Enter C from the keyboard. [C] will be displayed.

The change to [AC] is completed.

4. Press <START> to proceed with sewing or <END> to edit.

4 Setting the letter spacing

Entering the space ($\rightarrow\leftarrow\uparrow\downarrow$) codes will shift the letters 1 mm each in the direction of the arrow.

Changing the enlargement and reduction ratio can also change the spacing of each arrow from 0.1 - 9.9 mm.

To shift the letters more than 9.9 mm, simply enter multiple arrows and change the ratio as required.

For example, to shift the letters AB 15 mm apart, insert two arrows (1) and (2) $A\rightarrow\rightarrow B$, and specify an enlargement of 7 times for arrow (1), 8 times for arrow (2). Since $7 + 8 = 15$, the letters will move 15 mm apart.

Reduce the lateral spacing between A and B

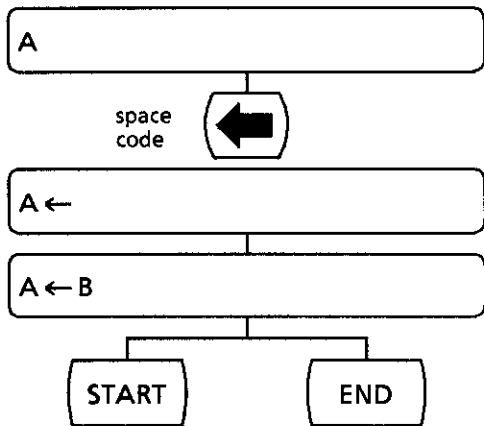

1. Enter <A> from the keyboard.

[space code key]

2. Press the space code key.

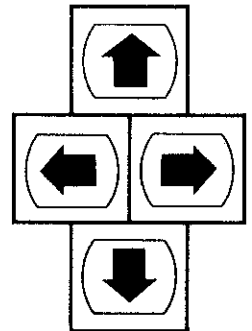

3. Enter from the keyboard.

A ← B is entered.

Press <START> to proceed with sewing, <END> to edit.

* To increase letter spacing, enter space code $\leftarrow\rightarrow$ in step 2 above.

* Press <START> to sew. See page 33.

* If an enlargement or reduction ratio is set and the arrow key is pressed in the input mode, the space code will not be set to the default value. See page 48 for individual settings.

To change the spacing between letters

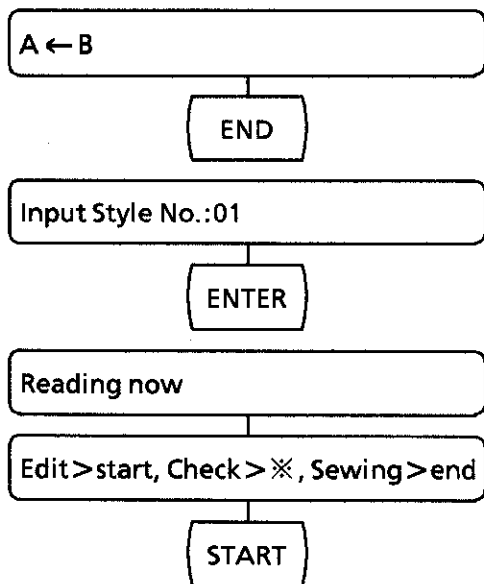

Set the spacing between A and B to 1.2 mm.

1. Press <END>.

2. Press <START>.

1 Area 2 Enlarge or Reduce

3 Thr. density, Letter width

4 Arrange 5 Rotation 6 Center.

7 Stitch

3. Press <2> to select [2. Enlarge or Reduce].
Press <2> on the sewing machine operation panel.

2

1 By magnifi. 2 By ttl. length

1

1 Altogether 2 Individual

2

A ← B



A ← B



1 0.1 - -

2 1.2 - -

ENTER

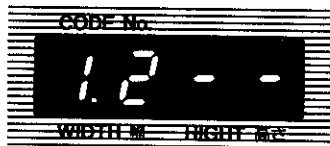

END

Use the operation panel on the sewing machine to enter the edit contents.

4. Press <1> to select [1. By magnifi].

5. Press <2> to select [2. Individual].

If a different ratio has already been set, that ratio will be shown in the blinking LED.

6. Press the jog key <FWD>. The cursor will move under the <<=>, and the width ratio [1.0] for the space code will be displayed with a blinking LED.

7. Enter the numbers [1][2]. The width ratio [1.2] for the space code will appear on the blinking LED.

8. Press <ENTER>. The width ratio [1.2] for the space code will be entered.

9. Press <END>. The size of the space code <<=> will be saved. The edit menu will be alternately displayed.

10. To proceed with sewing, press <END>.

- 1 Area 2 Enlarge or Reduce
- 3 Thr. density, Letter width
- 4 Arrange 5 Rotation 6 Center.
- 7 Stitch

Letter spacing greater than 9.9 mm (15 mm in this example)

Use the operation panel on the sewing machine to enter the edit contents.
Set the spacing between <A> and to 15 mm.

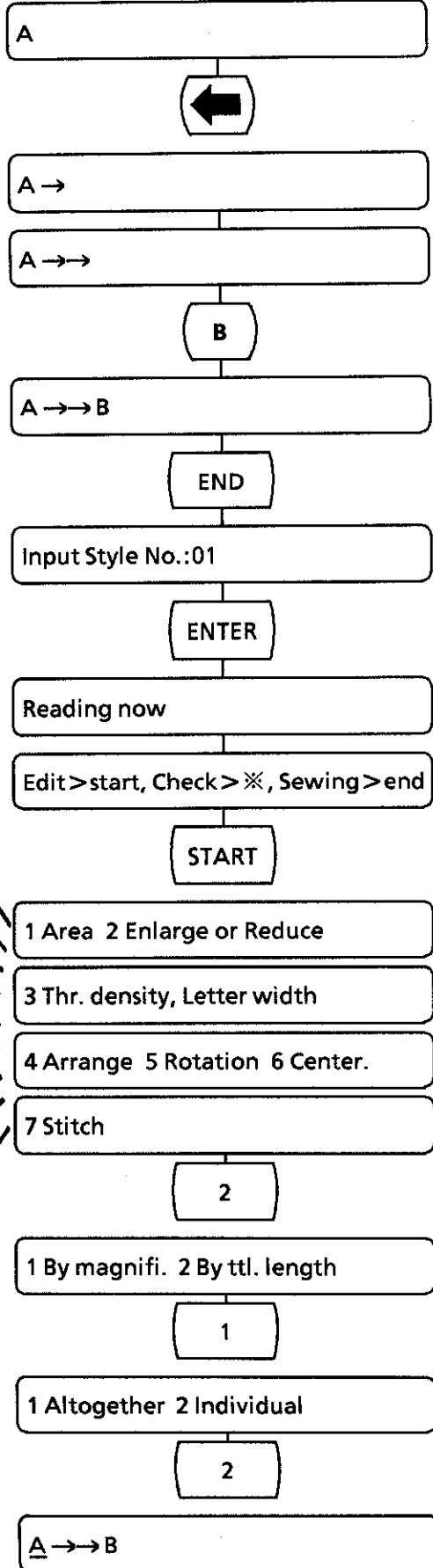

1. Enter <A>, and then press the right <→> space code key. <→> will be displayed. The first left space is entered.
2. Again press the right <→> space code key. <→> will be displayed. The second left space is entered.
3. Enter from the keyboard. The B is entered.
4. The size of the <→> is to be changed. Press <END> to enter the edit mode.
5. Press <ENTER>.

6. Press <START> and select the edit mode.

The edit menus will be alternately displayed.

7. Press <2> to select [2. Enlarge or Reduce].
8. Press <1> to select [1. By magnifi].
9. Press <2> to select [2. Individual].

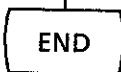
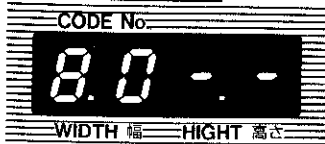
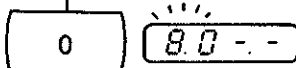
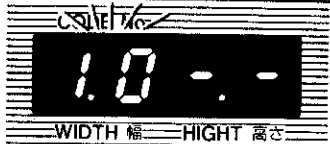
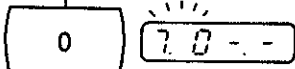
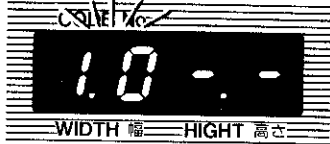

- 1 Area 2 Enlarge or Reduce
- 3 Thr. density, Letter width
- 4 Arrange 5 Rotation 6 Center.
- 7 Stitch

※ If a different ratio has already been set, that ratio will be displayed.

10. Press the jog key <D>. The cursor will move under the <→>, and the width ratio [1.0] for space code will be displayed.

11. Enter the numbers [7][0]. The width ratio [7.0] for the space code will be displayed.

12. Press <ENTER>. The width ratio [7.0] for the space code will be entered.

13. Press the jog key <D>. The cursor will move under the second <→>, and the width ratio [1.0] for the space code will be displayed.

14. Enter the numbers [8][0]. The width ratio [8.0] for the space code will be displayed.

15. Press <ENTER>. The width ratio [8.0] for the space code will be entered.

16. Press <END>. Press <END> to proceed with sewing.

The width of the first space code is now 7.0 mm, and the second space code is 8.0 mm, enabling the B to be shifted a total of 15 mm.

The edit menu will be alternately displayed.

To confirm the edit contents, press <* >. See page 69.

To sew, press <END>. See page 33.

5 Pause

When a pause symbol (*) is entered between characters, embroidering is suspended.

A * B

Re-start > start, Quit > clr

START

Sewing resumes.

Enter a pause symbol (*) in front of the character that you want to suspend embroidering for.

Embroidering is suspended before the letter "B," is embroidered, and the indication shown in the left figure, will appear.

Press <START> to start embroidering the letter "B,".

※ The asterisk code is <2A>.

※ "*" is displayed on the machine by pressing the pause key  on the keyboard.

Space codes and sewing position

If ABC is set laterally

Space code	1F	1E	1C	1D
Display	A←BC	A→BC	A↑BC	A↓BC
Sewing position				

If ABC is set vertically

Space code	1F	1E	1C	1D
Display	A←BC	A→BC	A↑BC	A↓BC
Sewing position				

Applications

The following alignments and monograms can be sewn by entering various space codes.

6 Carriage return

Brother ↵ Mike

(With centering)

Brother
Mike

(Without centering)

Brother
Mike

In the text entry mode enter the carriage return before the letter which is to start the next line.

The carriage return code is <7F>.

NOTE:

If you start sewing using data starting with ↵ , ↑, ↓, ←, →, incorrect positioning will be performed; please make sure data is correct before starting.

























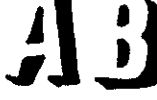

FONT SELECTION

Selecting fonts for letters and numbers

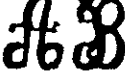
Different fonts can be selected after entering the letters (upper or lower case) and numbers.
There are 28 fonts available.

Set the font code using the operation panel on the sewing machine.

Normal scaling up or down (0.1 to 9.9 times) is available.

 Font code 01	 Font code 02	 Font code 03	 Font code 04
 Font code 05	 Font code 06	 Font code 07	 Font code 08
 Font code 09	 Font code 10	 Font code 11	 Font code 12
 Font code 13	 Font code 14	 Font code 15	 Font code 16
 Font code 17	 Font code 18 [ⓑ]	 Font code 19 [ⓑ]	 Font code 20
 Font code 21 [ⓑ]	 Font code 22	 Font code 23 [ⓑ]	 Font code 24 [ⓑ]
 Font code 25 [ⓑ]	 Font code 26 [ⓑ]	 Font code 27 [ⓑ]	 Font code 28 [ⓑ]

[ⓑ] This font is available only in capital letters.

Example 1

To embroider the letters

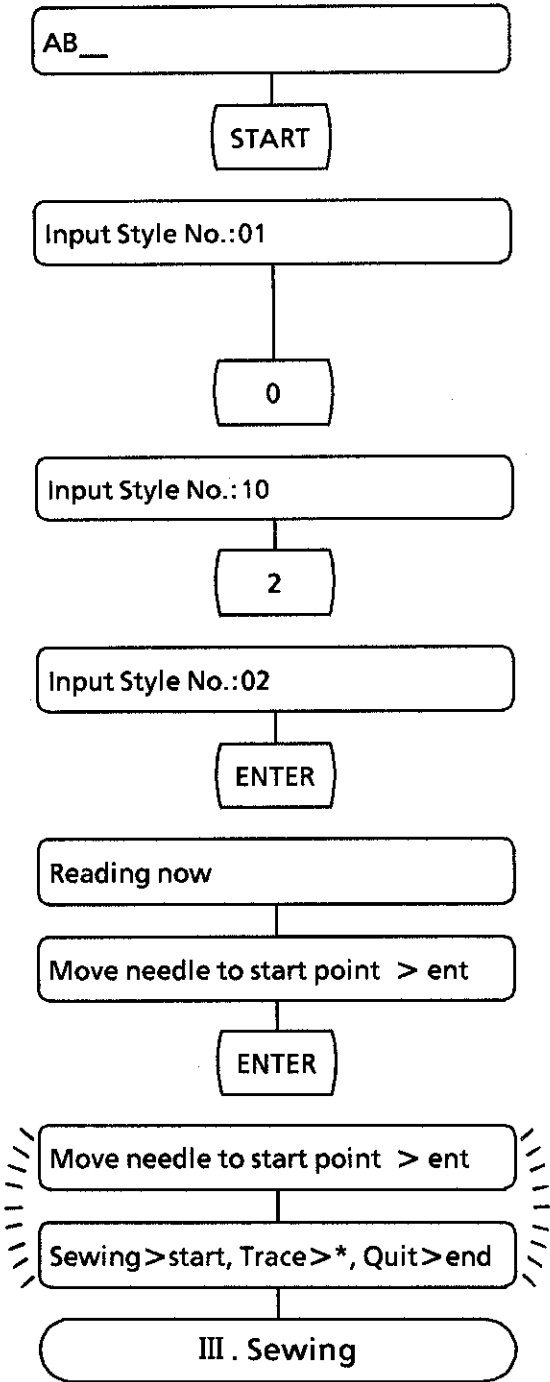

1. Press <START>.
 - Font number <01> will be displayed.
 - * 1. Font number <01> is displayed in the default setting mode.
If a different font has been specified, that font number will be displayed.
 - * 2. The font number is always a two-digit number.

2. Press <0>.

The <1> will be carried to the upper digit, followed by <0>.

3. Press <2>.

The 0 will be carried to the upper digit, followed by 2.

4. Press <ENTER>.
 - The AB monogram will be set to font number <02>.

Shown while the floppy disk drive indicator is on.

Shown when the floppy disk drive indicator goes out.
* The current needle position is the needle start position.

5. Use the jog keys to set the needle start position, and then press <ENTER>.

The needle start position will be set and this menu will be displayed.





Select [Sewing] [Trace] [Quit] by pressing the appropriate key.

→ P. 33

Example 2 Letter monogram specifications (optional)

Data arrangement and sewing start position

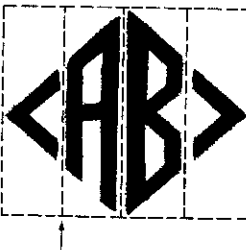
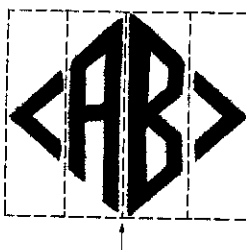
The arrow in the figures below indicates the sewing start position.

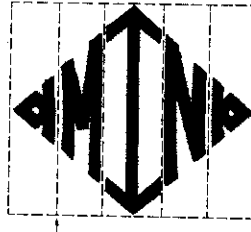
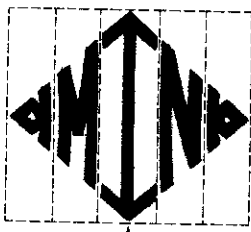
2 Letter			
No decoration		With decoration	
Centering OFF	Centering ON	Centering OFF	Centering ON
			
3 Letter			
No decoration		With decoration	
Centering OFF	Centering ON	Centering OFF	Centering ON
			

If you want to change fonts from the one used on the current floppy disk to another one; turn off the power, replace the floppy disk with another one, and turn on the power again.

To sew without additional decoration

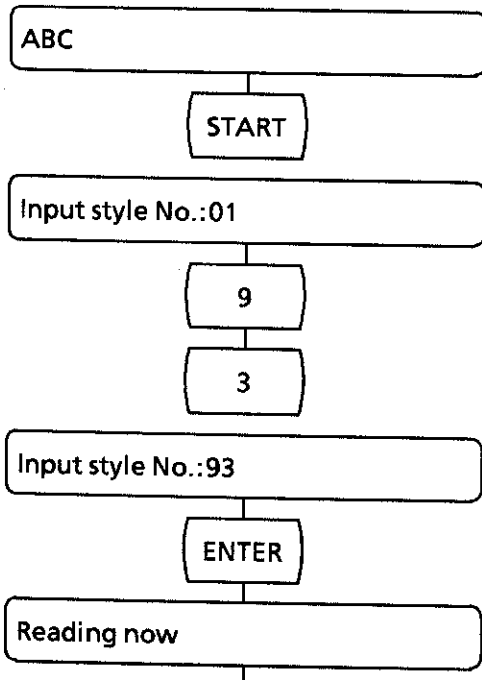

1. Enter ABC from the keyboard in the text entry mode.
2. Press <START>.
3. Enter the 3 letter code using the key panel. Press <9>, <3>.
Enter <9><2> for two letters, or <9><1> for one letter.
4. Press <ENTER>.

Decorative marks " ◻ mark
! < > mark
& ◊ ◊ mark

NOTE: These decorative marks should be entered at the end of the text.

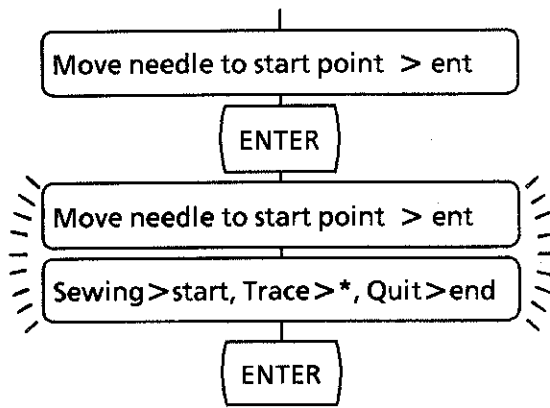

5. Set the needle start position with the jog keys.
6. Press <ENTER>.
7. Press <START >. Sewing start.

To sew with additional decoration

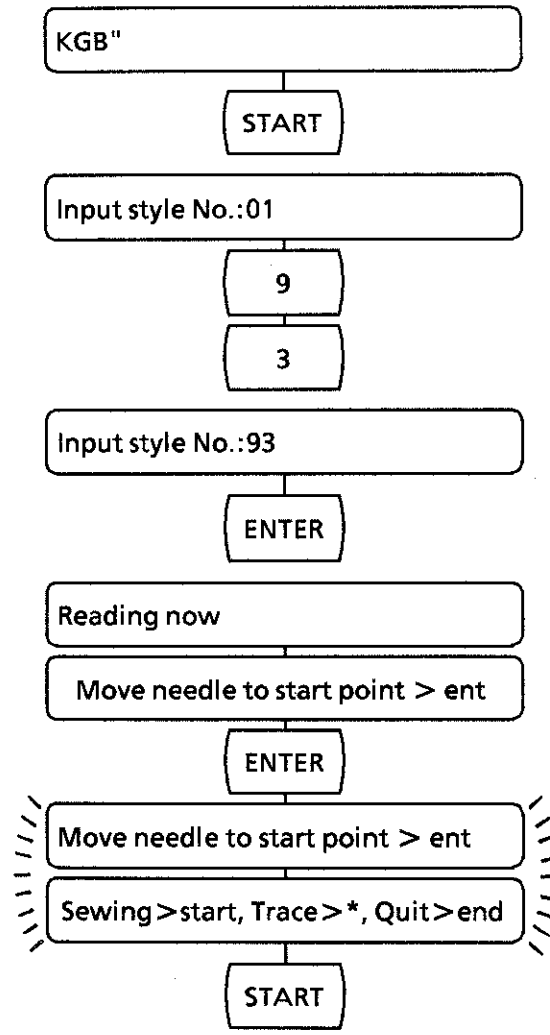

1. Enter the letters and bracket code <"> using the keyboard.
2. Press <START>.
3. Enter the 3 letter code using the key panel.
Press <9><3>.
For a two letter code, enter <9><2> or <9><1> for one letter.
4. Press <ENTER>.
5. Set the needle start position with the jog keys.
6. Press <ENTER>.
7. Press <START >. Sewing start.

NOTES:

1. Be sure to insert the dedicated three letter code disk (for sewing 1 to 3 letters) before entering the code. An entry error will occur if font numbers 91, 92, or 93 are entered and the disk is not one for three letter codes. There are cases in which an entry error may not be displayed. In this case, the correctly displayed letters will not be sewn and other letters will be instead.
2. Be sure the number of letters entered and the font number match. If, for example, only two letters are entered but the font number is 91 or 92, an entry error will occur or different letters will be sewn.
3. Only capital letters are stored on disks as three letter codes. If lower case letters are used, but the correct disk for the three letter code is inserted, the font number is correct, and code 91, 92, or 93 is entered, letters other than those displayed may be sewn.

III. SEWING

1 Sewing

Sewing preparations

Insert the floppy disk and select the letters before starting to sew.

Example 1

AB__

START

1. Press <START>.

Input Style:01

ENTER

Reading now

Move needle to start point > ent

ENTER

Shown when the floppy disk drive indicator goes out.

* The current needle position is the needle start position.

2. Use the jog keys to set the needle start position, and then press <ENTER>.

Move needle to start point > ent

The needle start position will be set and this menu will be displayed.

Select [Sewing] [Trace] [Quit] by pressing the appropriate key.

Sewing>start, Trace>*, Quit>end

Sewing > start, Trace > *, Quit > end

To sew the displayed letters, press <START>.

Sewing

→ See page 33.

To check and trace the letters to be sewn, press <*>.

Test sewing

→ See page 36.

To exit without sewing the displayed letters, press <END>.

Cancel

→ See page 37.

[Sewing start]

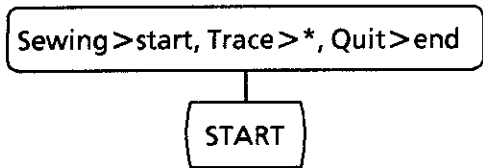

AB

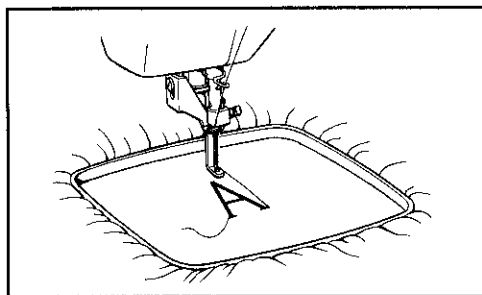

B

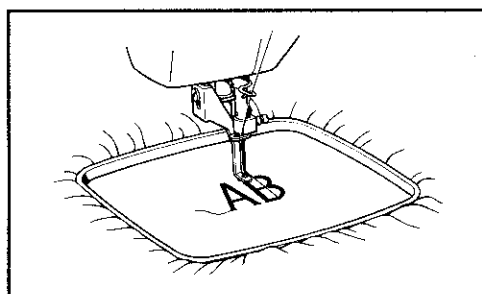

1 Input 2 Resewing 3 End
4 Replace FD 5 Entry

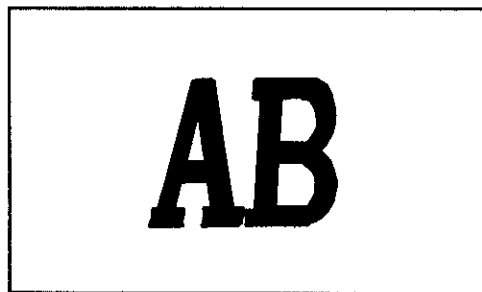

3. Press <START>, and select [Sewing].

A, B will be displayed, and sewing will start.

* Letters will be sewn in an order different from that actually written.

When the first letter, A, is completed, it will be deleted from the display.

When sewing is completed, the needle will return to the needle start position, and the indications shown on the left will be displayed alternately. Sewing of the monogram is now over.

To change the monogram letters, enter 1. (See page 38.)

To sew the same monogram again, enter 2. (See page 38.)

Press number key <4> on the operation panel on the sewing machine to use the optional design floppy disks. (See page 40.)

To save the data of characters that have been embroidered, press <5> on the operation panel. (Refer to page 73.)

- * 1. The selected letters and settings (or default) will remain selected after sewing is completed until the settings are changed by the operator.
- * 2. The selected letters and settings will remain selected for about one week if the power switch is turned off.
- * 3. If the thread breaks while sewing, **Thread breakage** and **Press end Key** will be alternately displayed, and an alarm will sound. **Re-start > start, Quit > clr** will be displayed when <END> is pressed. Rethread, return the needle to where the thread broke using the jog keys (REV., FWD.), and then press <START>.
- * 4. If sewing is paused to change thread colors, or if the emergency stop function is used, press any key on the machine operation panel to resume sewing.

2 If "Area over" is displayed

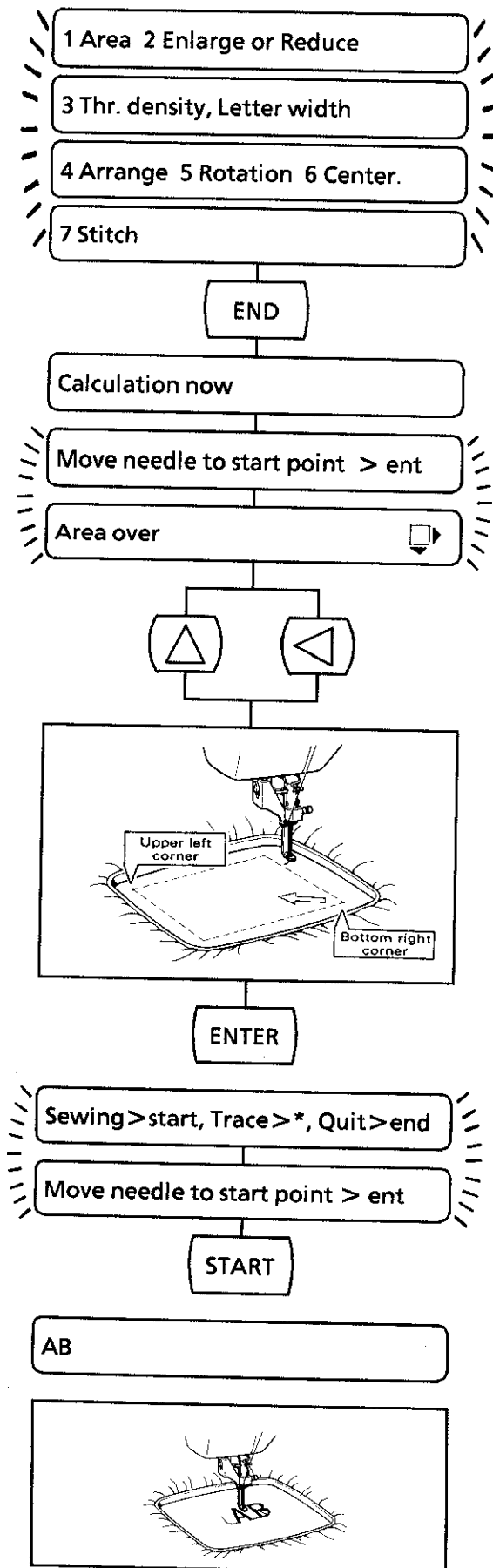

1. Press <END>.

Shown while the floppy disk drive indicator is on.

Shown when the floppy disk drive indicator goes out.

Alternately displayed.

The area is overrun in the directions indicated by the arrow(s).

* The current needle position is at the bottom right corner.

2. Press jog keys <△> and <◁> to move the needle position in the direction opposite to the arrows <◻>.

* The actual needle start position will vary with the lateral/vertical, rotation, and centering settings of the monogram. See page 68.

The alternating displays will stop when the needle position is moved to a position where sewing is possible.

* If the jog keys are pressed for too long, the area may be overrun in a different direction, and different arrows will then be displayed.

3. Press <ENTER>.

The needle start position is set.

4. Press <START> and select [Sewing].

AB will be displayed and sewing will start. See page 33.

3 Test sewing

The size and position of monogrammed letters can be tested before actual sewing using the confirm/test key <*>.

Example 1 Monogram AB.

Sewing>start, Trace>*, Quit>end

※

AB

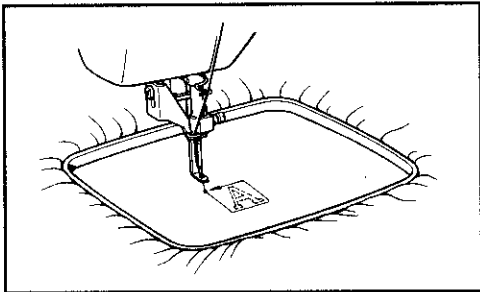

B

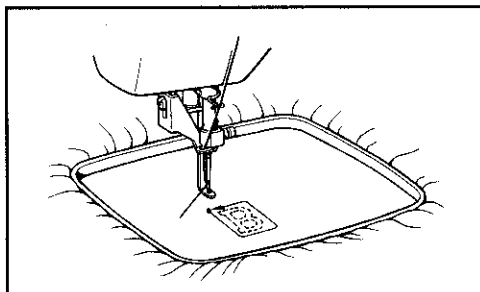

Sewing>start, Trace>*, Quit>end

Move needle to start point > ent

1. Press the confirm/test key <*> and select [Trace].

AB will be displayed and confirmation of the position of each letter will start.

The needle will trace around the area in which the <A> will be sewn.

When the first letter, <A>, is completed, it will be deleted from the display.

The needle will trace around the area in which the B will be sewn.

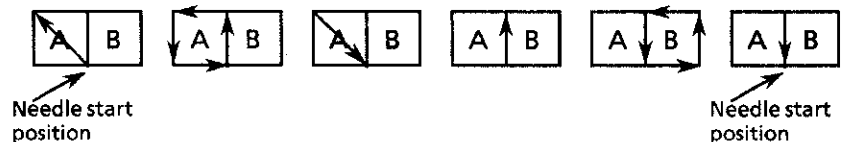

When tracing is completed, the needle will return to the needle start position, the indications shown on the left will be displayed alternately.

Confirmation of the pattern area is now completed.

To sew the monogram letters, press <START>. (See page 33.)

To exit without sewing the displayed letters, press <END >. (See page 38.)

To change the needle start position, select [Clear], press END, and then select [2. Resewing].

To change the letter size, select [Quit], press <END>, and then select [1. Input]. In the input mode, edit the letters to be sewn.

- * 1. Only the embroidery hoop will move during confirmation of letter position.
- * 2. To stop letter position confirmation, press any key on the machine operation panel. The needle will return to the needle start position.

4 To change the sewing start position after test sewing

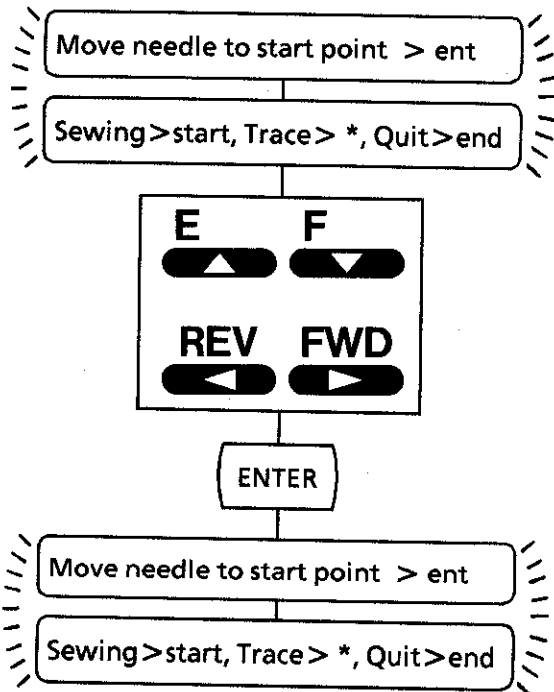

These messages will be alternately displayed. Press the jog keys to move the needle to the new start position, and then set the sewing start position again.

Use the jog keys to set the needle start position, and then press <ENTER>.

Press <※> for test sewing. If sewing is OK after confirming the pattern with the test operation, press <START>.

5 Cancel

Sewing and the confirmation/test mode can be cancelled, and the monogram letters changed or modified.

To cancel and stop sewing or confirmation.

1. Press <END> and select [Quit].

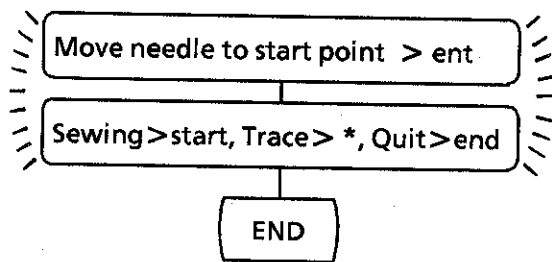

The same display which appears after sewing is completed will appear.

Select [1. Input or 2. Resewing 3. End 4. Replace FD 5. Entry].

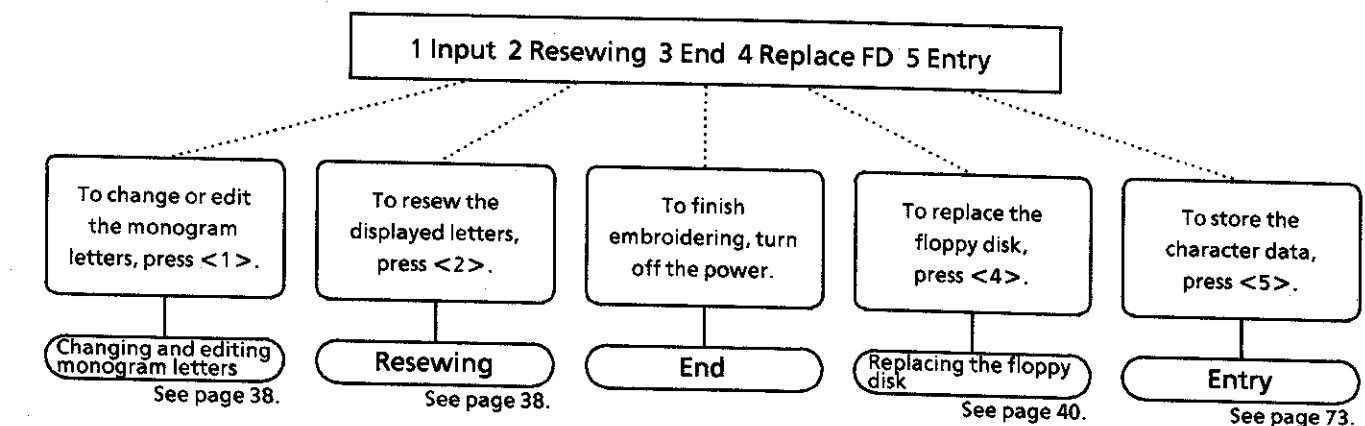

RESEWING

1 Changing and editing monogram letters

The monogram letters can be changed or edited after sewing is completed.

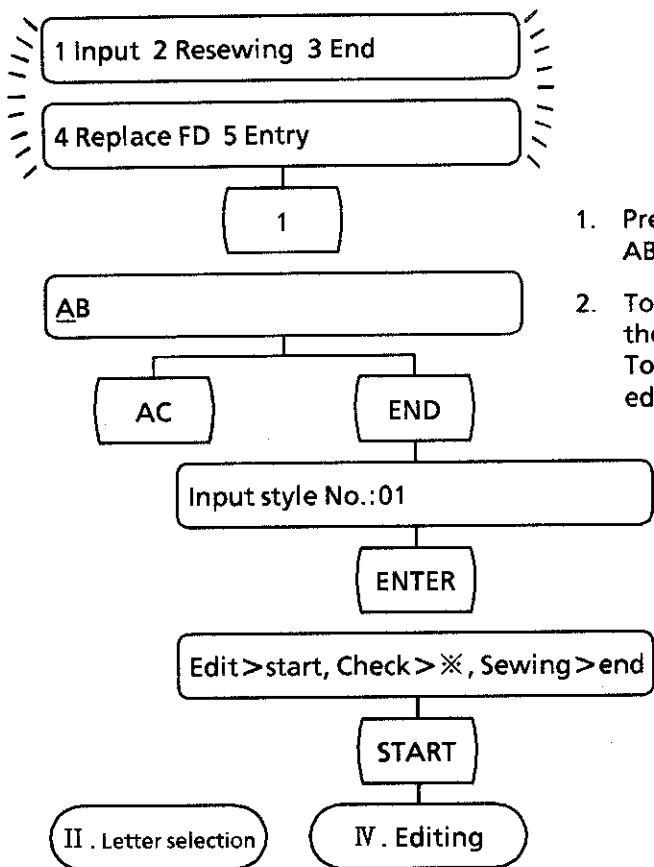

1. Press <1> to select [1. Input].
AB will be displayed.
2. To edit the monogram, press <AC> or <CLR> and select the new letters. See page 20.
To edit the same letters, "AB", press <END> and select the edit item. See page 42.

2 Resewing

The same monogram can be resewn after sewing is completed.

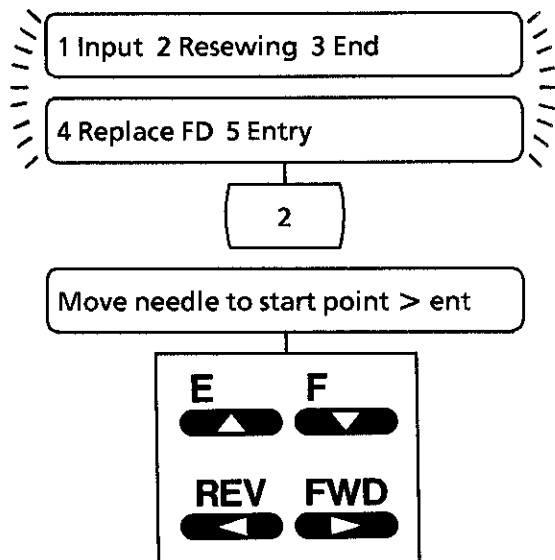

1. Press <2> to select [2. Resewing].
 2. To sew on the same piece of material, move the needle position using the jog keys, and set a new needle start position.
- * If the jog key is pressed for too long and the sewing area is overrun, [area over] and [Move needle to start point > ent] will be alternately displayed. Move the needle back in the direction indicated by the displayed arrow to set the needle position.

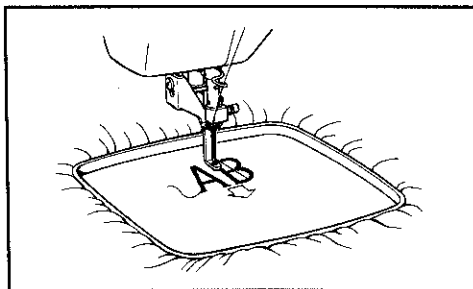

Move needle to start point > ent

ENTER

Sewing>start, Trace>*, Quit >end

Move needle to start point > ent

START

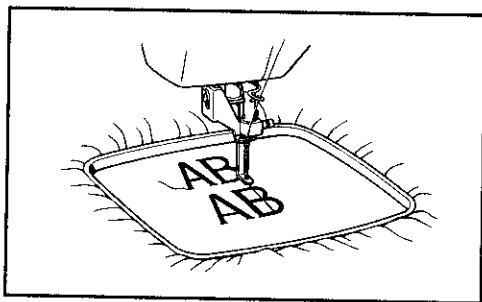

3. Press <ENTER>.
The new needle start position is set.

4. Press <START> and select <Sewing>.
AB will be sewn again.

③ Replacing the floppy disk

The font used to monogram letters can also be changed by changing the floppy disk. Optional design pattern disks can also be used.

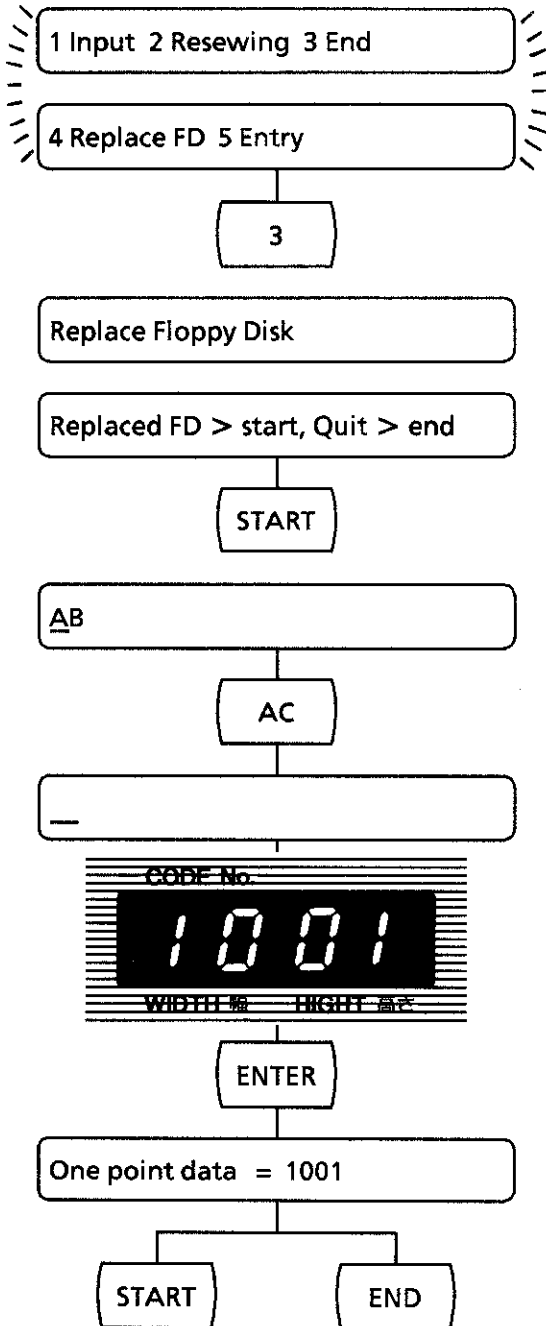

1. Press <4> and select [4. Replace FD]. These messages will be alternately displayed.

2. Insert the optional font disk or optional design pattern disk, and press <START>. [AB] will be displayed and the font will be changed.

* If the floppy disk is not changed, press <END>. [AB] will be displayed.

* To use the design pattern disks, press <AC> on the operation panel to clear the indication, and enter the desired single character data code number using number keys.

3. Input the single character data code. Press <1>, <0>, <0>, and <1> in this order.

4. Press <ENTER>.

5. Press <START> to start sewing; press <END> to enter the editing mode.

IV. EDITING

1 Editing letters and numbers

Example 1 Edit the letters AB.

AB__

END

1. Press <END>.

Input Style No.:01

0

Input Style No.:10

2

2. Select the font.

Examples

- 01 Gothic
- 02 Cursive
- 03 Floral
- 04 Italic

Input Style No.:02

ENTER

3. Press <ENTER>.

When the font change is cancelled, press <END>. The messages, **Not Changed** and **Press end key** will be displayed alternately.

Press <END> again.

Shown while the floppy disk drive indicator is on.

Shown when the floppy disk drive indicator goes out.

Reading now

Edit>start, Check>✳, Sewing>end

START

4. Press <START> and select [Edit].

The edit menu will be alternately displayed.

Select a function: **1 Area, 2 Enlarge or Reduce,**
3 Thr. density, Letter width, **4 Arrange, 5 Rotation, 6 Center,**
7 Stitch.

* To confirm the edit contents, press <*>. See page 69.

* To sew, press <END>. See page 33.

1 Area 2 Enlarge or Reduce

3 Thr. density, Letter width

4 Arrange 5 Rotation 6 Center.

7 Stitch

2 Edit item selection

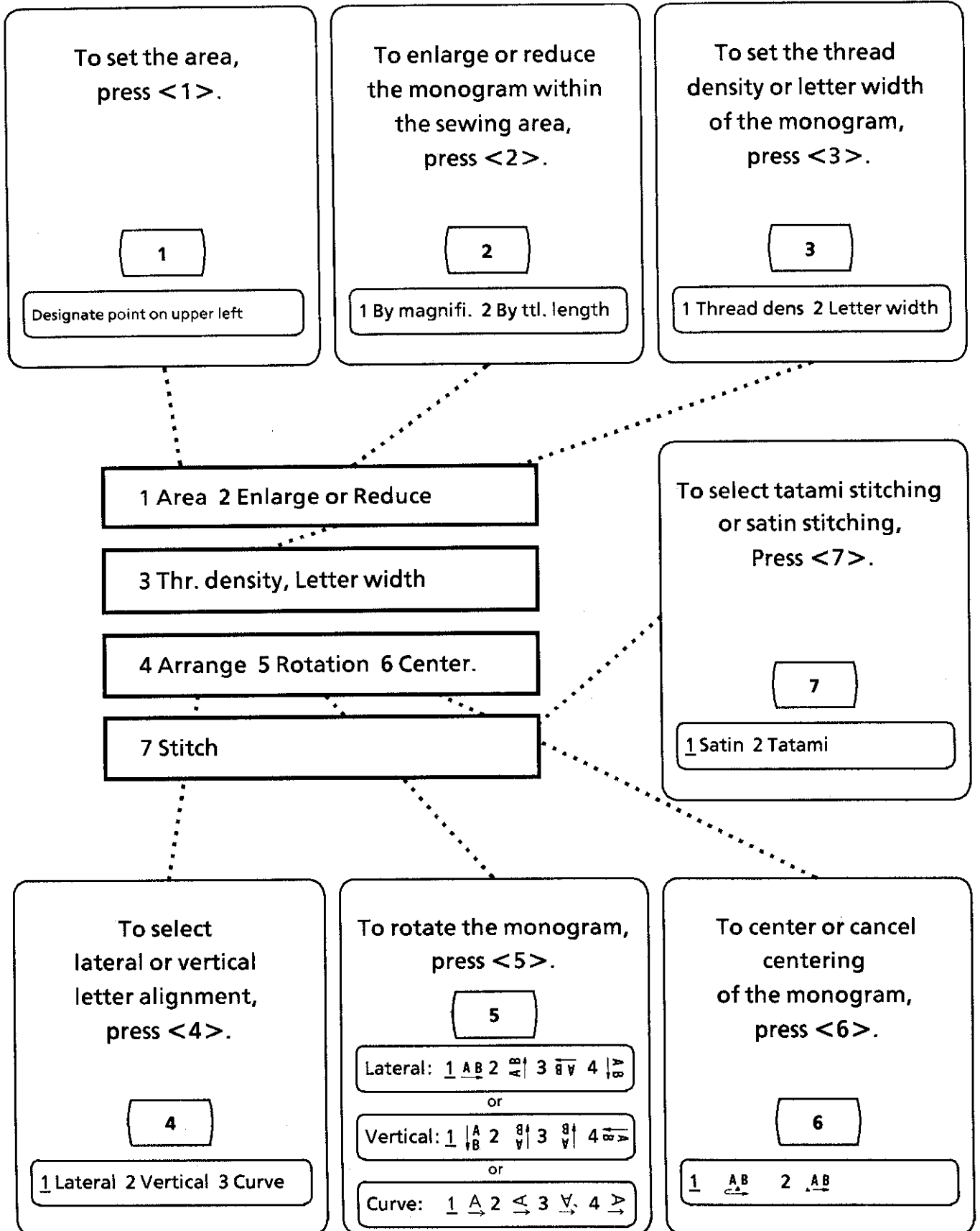

3 Setting the sewing area

Sewing are can be set by either of the following:

1. Inputting hoop number
2. Specifying sewing area corners (left upper and right bottom corners)

E.g. Setting sewing area for hoop number 02

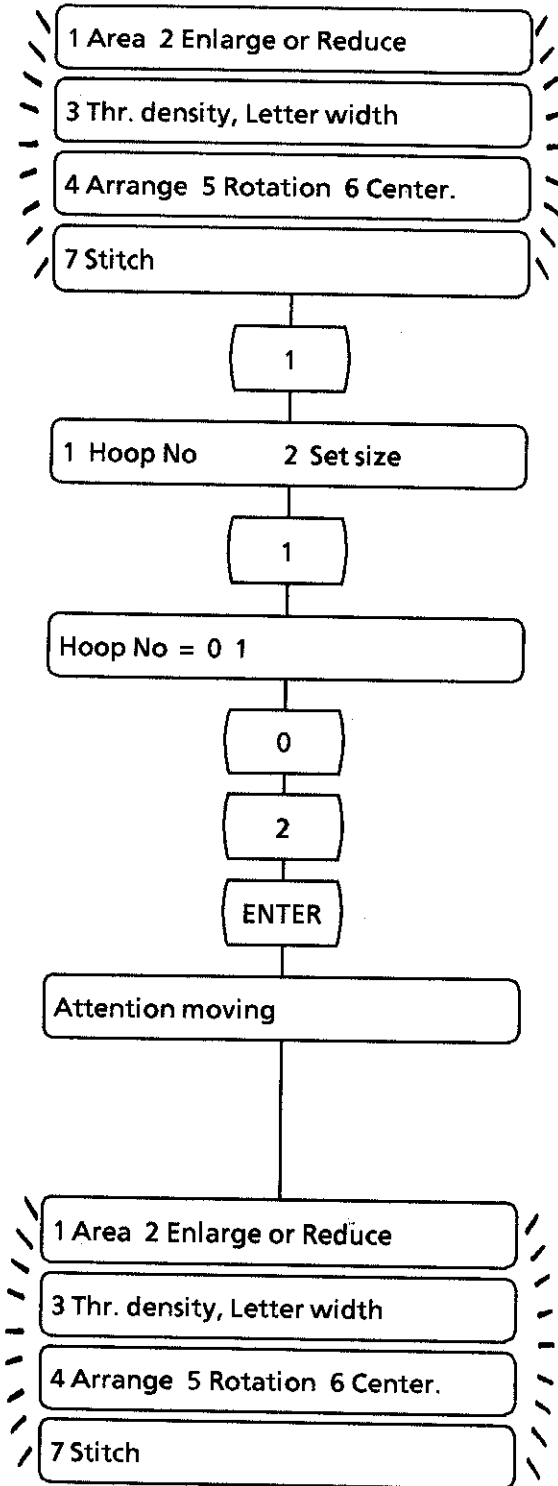

Input characters, and press the <END> and <START> keys. The editing menu will appear on the display.

1. Press the <1> key to set the sewing area.

2. Press the <1> key to select hoop number.
NOTE: If you press the <2> key, refer to the BAS-47 instruction manual.

The current set hoop number will appear.

3. Input hoop number (02), and press the <ENTER> key. The hoop number should be input with two digits.

The hoop will move to the center of the area, beeping four times as it does.

NOTE: When moving, the hoop may hit the presser foot or a screw. It is recommended that the hoop is attached after moving to the center of the area.

4. Sewing area for hoop number 02 is set.

NOTES

- 1) When <*> key is pressed with this display, area dimensions will appear.
- 2) The hoop number will appear on the display when setting the sewing start point. (When setting sewing area by specifying corners, "00" will appear.)

Hoop number and sewing area

Number	Hoop type	Hoop shape	Area dimensions (mm)	Remarks
01	HA	Rectangle	120 × 100 (length x width)	
02	D	Oval	66 × 32 (length x width)	
03	E	Oval	36 × 64 (length x width)	
04	A	Circle	112 (Diameter)	Option
05	B	Circle	80 (Diameter)	Option
06	C	Circle	34 (Diameter)	Option
07	F	Oval	36 × 64 (length x width)	Option
08	3 × 6	Oval	112 × 52 (length x width)	Option
09	G	Rectangle	66 × 32 (length x width)	Option
10	For thick material	Rectangle	120 × 100 (length x width)	Option

NOTE: The effective width for hoop no. 04 is 100 mm. The effective length for hoop no. 08 is 120 mm.

Embroidery hoop number

Standard hoops

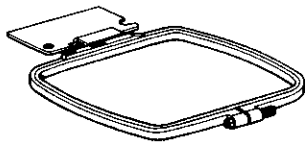

01

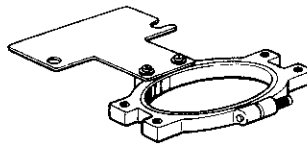

02

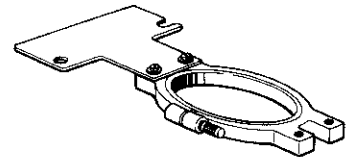

03

Optional hoops

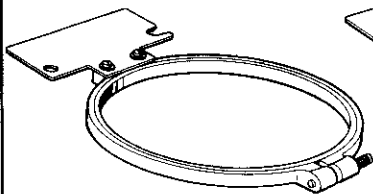

04

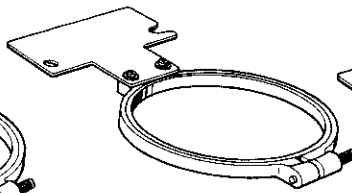

05

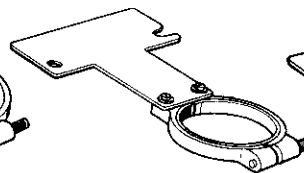

06

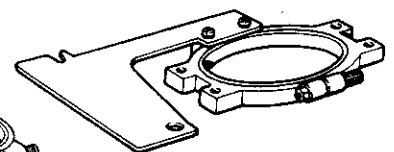

07

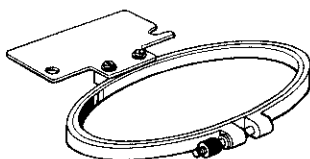

08

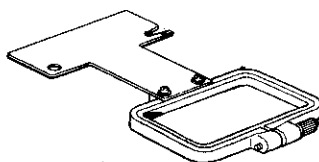

09

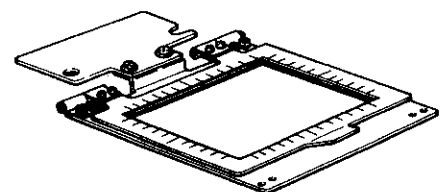

10

E.g. Setting the monogram area

This is used to set the monogram area within the embroidery hoop.
 Maximum sewing areas for the hoops are shown in the figures below.
 The monogram area is determined by setting the upper left corner and the bottom right corner.

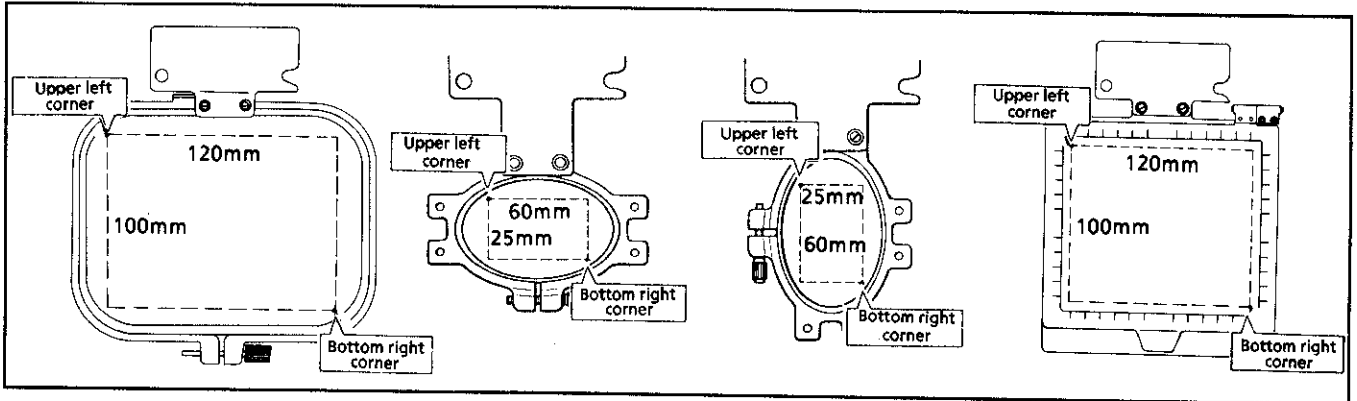

- 1 Area 2 Enlarge or Reduce
- 3 Thr. density, Letter width
- 4 Arrange 5 Rotation 6 Center.
- 7 Stitch

1

1 Hoop No 2 Set size

2

Designate point on upper left

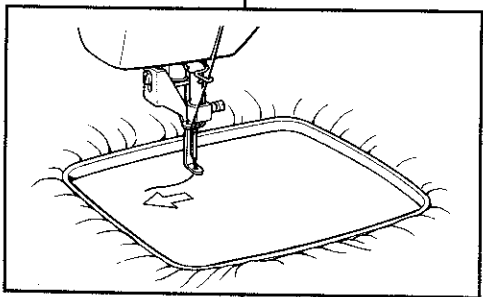
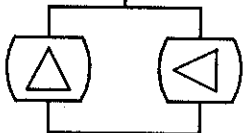

Designate point on upper left

See next page.

- * 1. Set the area with the embroidery hoop installed. The area must be contained within the hoop.
- * 2. The size and position of the monogram letters are determined by the size of the area.

1. Press <1> to select [1. Area].
2. Press the <2> key to select set size.
3. Use jog keys <Δ> and <◀> to move the needle position towards the top left of the embroidery hoop to determine the upper left corner inside the hoop.
 - * 1. **Turn pulley** will be displayed if the jog keys are pressed while the needle is down.

- * 2. **Designate point on upper** will be displayed until the corner is set.
 The position of the needle is the upper left corner.

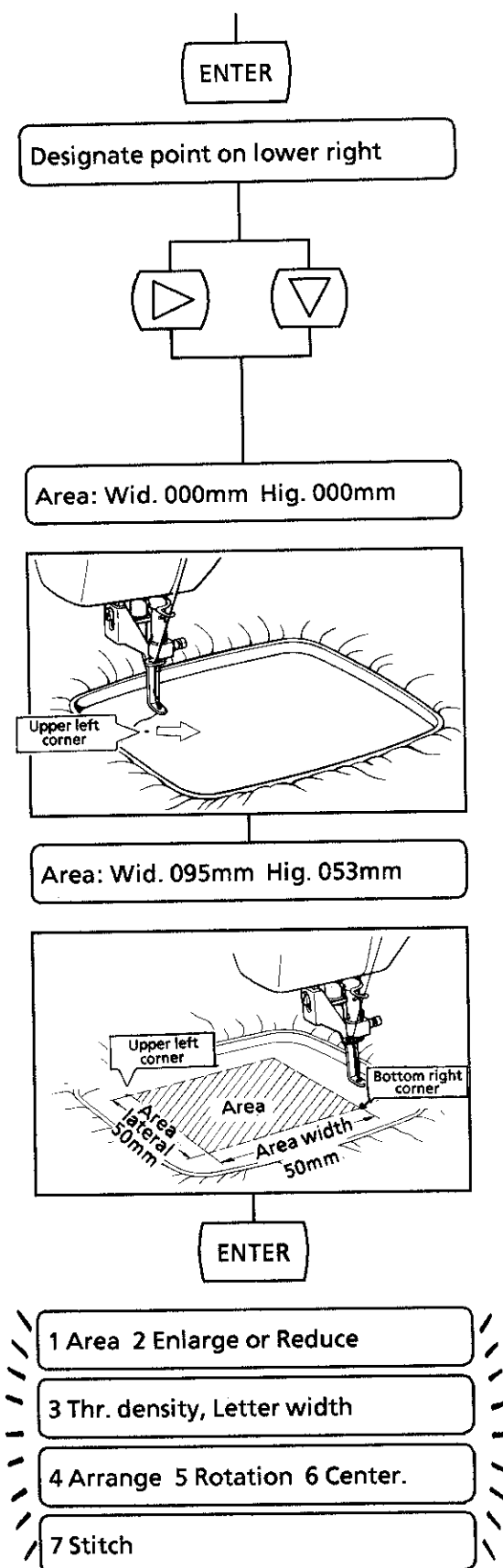

4. Press <ENTER>. The upper left corner is set. Displayed after the alarm sounds twice.
5. Press jog keys <▷> and <▽> to move the needle position towards the bottom right of the embroidery hoop to determine the bottom right corner inside the hoop.
 - * **Turn pulley** will be displayed if the jog keys are pressed while the needle is down.

* Width and height will be indicated by 3 digit numbers.

The distance of the needle position from the upper left corner along the X (width) and Y (lateral) axes will be displayed while the embroidery hoop is moving. The position of the needle is the bottom right corner.

6. Press <ENTER>. The bottom right corner is set. The edit menus will be alternately displayed.
 - * Press <END> to cancel and exit area specification before the setting is completed. **Not Changed** and **Press end key** will be displayed. Press <END> again.

- * 1. The largest possible area is 100 mm long by 120 mm wide.
- * 2. Setting a sewing area larger than the embroidery hoop will cause the needle to strike the frame during sewing. If the area is larger than the embroidery hoop, be sure to set the needle start position and reduction ratio to keep the monogram within the hoop.

4 If "Short of area" is displayed

This message will be displayed if the total sewing size is greater than the sewing area. Use the following procedure when [Short of area] is displayed.

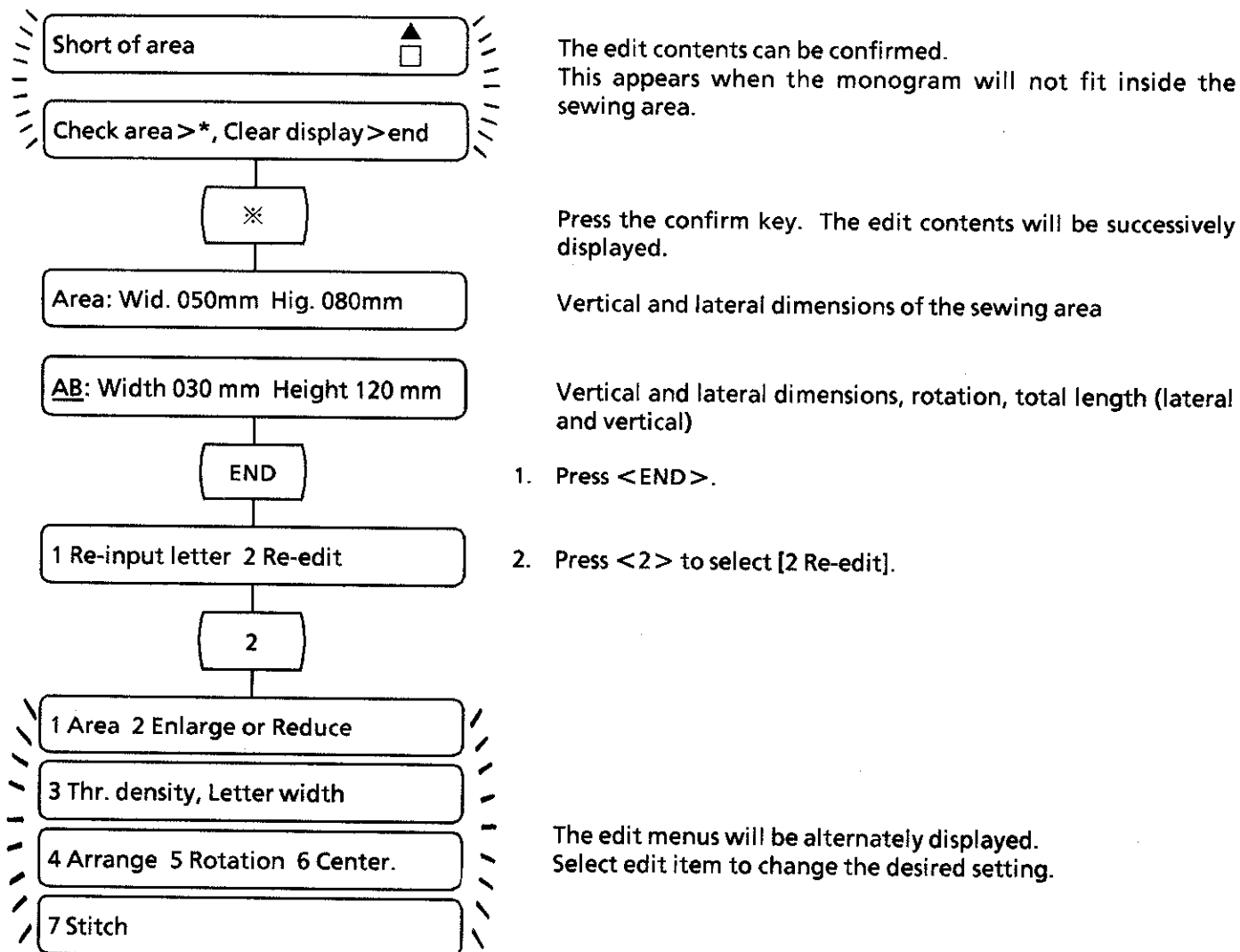

NOTE 1) When the sewing area is reset ("1 Area" is selected), it should not exceed the embroidery hoop size. Refer to page 43.

NOTE 2) When "2 Enlarge or Reduce" is selected, characters can be enlarged or reduced by specifying the ratio and automatically calculating the total length. Refer to page 46.

NOTE 3) When "5 Rotation" is selected, reset the rotation angle so that the character is positioned within the set area.

5 Enlarging or reducing

The monogram can be enlarged or reduced within the set area.

Enlargement and reduction settings can be made in four ways; [Altogether] and [Individual] for the ratio, and [Auto] or [Designate dimension] for the length and width.

In the case that characters are enlarged resulting in a stitch length more than 12.7 mm, the needle point is placed at the middle of a stitch in order to change stitching. Refer to Tatami stitching, page 72.



A. Setting the size ratio Altogether

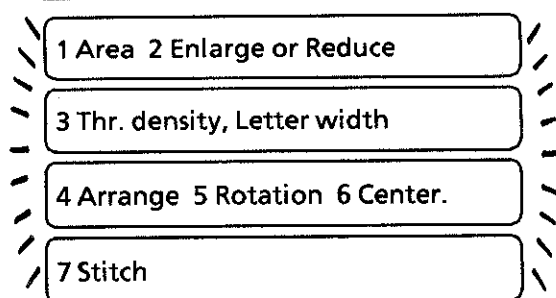

2

1 By magnifi. 2 By ttl. length

1

1 Altogether 2 Individual

1

1 Altogether 2 Individual



The enlargement and reduction ratio can be set in 0.1 unit increments. Changing the size ratio for one character automatically changes the sewing size ratio for the other characters, too.

1. Press <2> to select [2. Enlarge or Reduce].

2. Press <1> to select [1. By magnifi].

3. Press <1> to select [1. Altogether].

The LED indicator displaying the character width ratio 1.0 will blink.

* The display will show [1.0 1.0] in the default settings mode, and the width indicator will blink. If a different ratio has already been set, that ratio will be displayed.

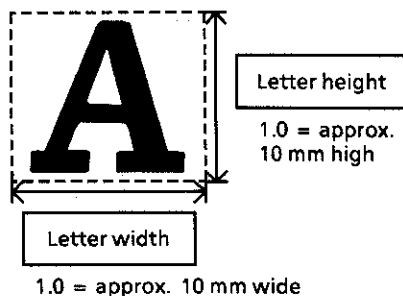

Width and height ratios can be varied from 0.1 - 9.9 times.

To change the size ratio for AB Altogether to width 1.5, height, 1.1.

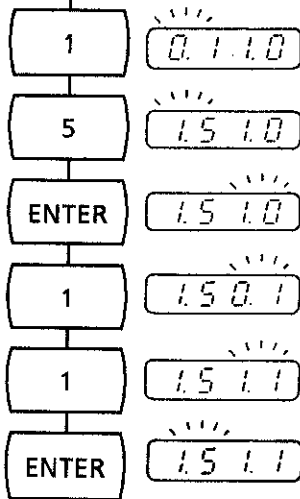

4. Press <1> and <5>.

The width ratio 1.5 will blink.

5. Press <ENTER>. The width ratio is entered. The height ratio 1.0 will now blink.

6. Press <1> and <1>.

The height ratio 1.1 will blink.

7. Press <ENTER>.

The height ratio is entered.

The width ratio 1.5 will now blink.

In the above example, the letters AB will now be sewn with a width 1.5 and height 1.1 times the standard size.

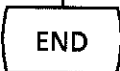
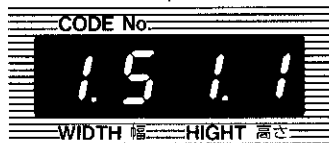

8. Press <END>.

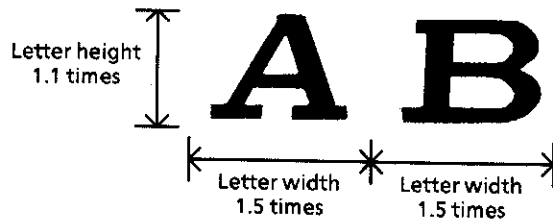
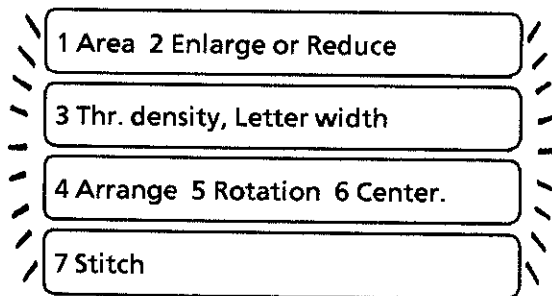

The setting for the monogram AB is now completed. The edit menu will be alternately displayed.



To confirm the edit contents, press <*>. See page 69.

To sew, press <END>. See page 33.

Letter width and height can be changed to alter the shape of the letters in the monogram.

Ratio	Width < height	Width = height	Width > height
Modified letter	 (Long, narrow)	 (Standard)	 (Flat)

* 1. Different letters may be of differing sizes even though the same size ratio is specified.

* 2. Sewing is not possible if the size ratio makes the letters larger than the specified area.

B. Setting the size ratio Individual (1)

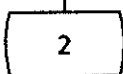
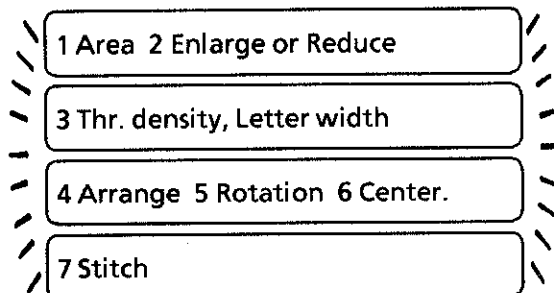

1. Press <2> to select [2. Enlarge or Reduce].

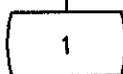
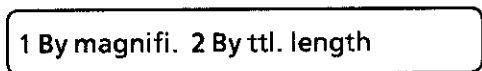

2. Press <1> to select [1. By magnifi].

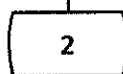
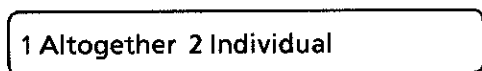

3. Press <2> to select [2. Individual].

The cursor will appear under the first letter, A, and the LED indicator will blink displaying the letter width ratio: 1.0.

* The display will show [1.0 1.0] in the default settings mode, and the width indicator will blink. If a different ratio has already been set, that ratio will be displayed.

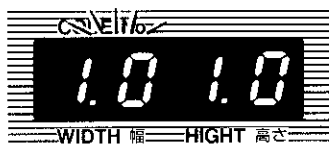
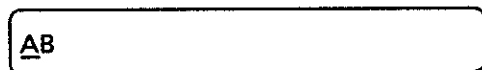

Set individual size ratios for the two letters AB.

A width ratio 1.5, height ratio 1.0
B width ratio 1.2, height ratio 0.9

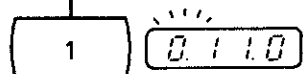

4. Press <1> and <5>.



The width ratio 1.5 for the letter A will blink.



5. Press <ENTER>.
The width ratio is entered.
The height ratio 1.0 will now blink.

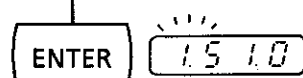

6. Press <ENTER>.
The height ratio 1.0 for the letter A is now set.
The width ratio 1.5 will now blink.

* If the ratio shown by the indicator does not need changing, simply press <ENTER>.
A width ratio of 1.5 and height ratio of 1.0 have now been set for the letter A.

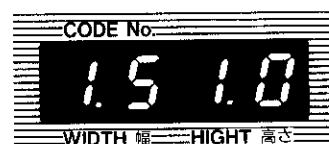

7. Press the <▷> jog key.

AB

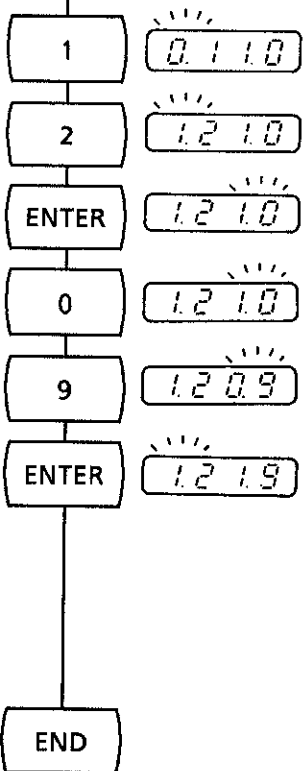

The cursor will move under the B, and the width ratio 1.0 will blink.

8. Press <1> and <2>.

The width ratio 1.2 for the letter B will blink.

9. Press <ENTER>. The width ratio is entered. The height ratio 1.0 will now blink.

10. Press <0> and <9>.

The height ratio 0.9 will blink.

11. Press <ENTER>. The height ratio 0.9 for the letter B is now set. A width ratio of 1.2 and height ratio of 0.9 have now been set for the letter B. The size ratio settings for the monogram AB are now completed.

12. Press <END>. The size ratio settings for the monogram AB are now completed. The edit menu will be alternately displayed.

- 1 Area 2 Enlarge or Reduce
- 3 Thr. density, Letter width
- 4 Arrange 5 Rotation 6 Center.
- 7 Stitch

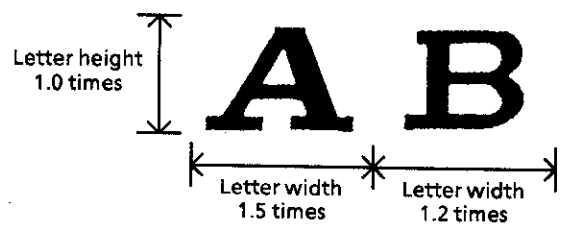

To confirm the edit contents, press <*>. See page 69.
To sew, press <END>. See page 33.

- * 1. After selecting Individual, use the <▷> and <◁>, jog keys to select the letter. The current size ratio will be shown in the LED.
- * 2. Sewing is not possible if the size ratio makes the letters larger than the specified area.

Setting the size ratio Individual (2)

Inserting and deleting letter data

Size ratios are not applied to a single specific letter, but to a position on the display, specifically, to certain display coordinates.

Because of this, changing the size ratio, sewing, and then adding or deleting letters may cause letter sizes to change as illustrated below.

Ex. 1

AB

[1st letter]

[2nd letter]

A

B

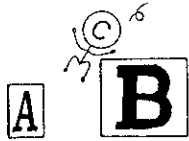

Letter width Letter height

0.6 1.0

[Ratio for 1st letter]

Letter width Letter height

2.0 1.5

[Ratio for 2nd letter]



ACB

If the letter C is inserted between A and B, the size ratios will change as follows.

[1st letter]

[2nd letter]

[3rd letter]



A

C

B

Letter width Letter height

0.6 1.0

[Ratio for 1st letter]

Letter width Letter height

2.0 1.5

[Ratio for 2nd letter]

Letter width Letter height

1.0 1.0

[Ratio for 3rd letter]

As illustrated above, when letters are moved, letter size is determined by the size ratio assigned to the letter position (coordinates).

Ex. 2

ACB

[1st letter]

[2nd letter]

[3rd letter]

A

C

B

A C B

Letter width Letter height
0.6 1.0
[Ratio for 1st letter]

Letter width Letter height
2.0 1.5
[Ratio for 2nd letter]

Letter width Letter height
1.0 1.0
[Ratio for 3rd letter]



CB

If the letter A is deleted, the size ratios change as follows.

[1st letter]

[2nd letter]

C

B

Letter width Letter height
0.6 1.0
[Ratio for 1st letter]

Letter width Letter height
2.0 1.5
[Ratio for 2nd letter]

As illustrated above, when letters are moved, letter size is determined by the size ratio assigned the letter position (coordinates).

Ex. 3

AB

[1st letter]

[2nd letter]

A

B

A B

Letter width Letter height
0.6 1.0
[Ratio for 1st letter]

Letter width Letter height
2.0 1.5
[Ratio for 2nd letter]



A ← B

When the left arrow (←) code is inserted to bring the letters closer together, the ratios change as follows.

[1st letter]

[2nd letter]

[3rd letter]

A

←

B

A ← B

Letter width Letter height
0.6 1.0
[Ratio for 1st letter]

Letter width Letter height
2.0 1.5
[Ratio for 2nd letter]

Letter width Letter height
1.0 1.0
[Ratio for 3rd letter]

Note that the spacing provided by an arrow insertion is 1 mm only when the size ratio for the insertion point coordinate is the default ratio [1.0 1.0]. If, as in example 3 above, the arrow is inserted at a point for which the size ratio is 2.0 the second letter, B, will be shifted 2 mm to the left.

C. Automatic calculation

Use automatic calculation for the monogram AB.

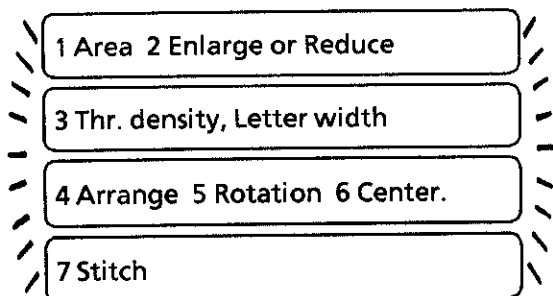

2

Letter size can be automatically calculated and sewn to fit the area.

1. Press <2> to select [2. Enlarge or Reduce].

1 By magnifi. 2 By ttl. length

2

2. Press <2> to select [2. By ttl. length].

1 Auto 2 Designate dimension

1

3. Press <1> to select [1. Auto].
The size ratio will be automatically calculated and set.
The edit menu will be alternately displayed.

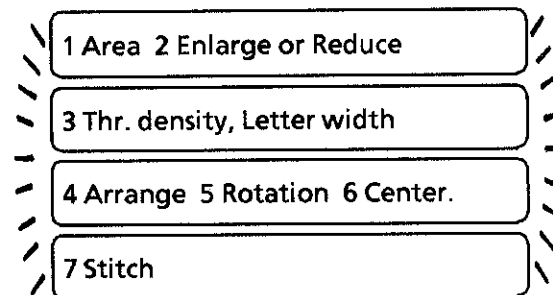

To confirm the edit contents, press <*>. See page 69.
To sew, press <END>. See page 33.

The size of the monogram will be determined by the area size.

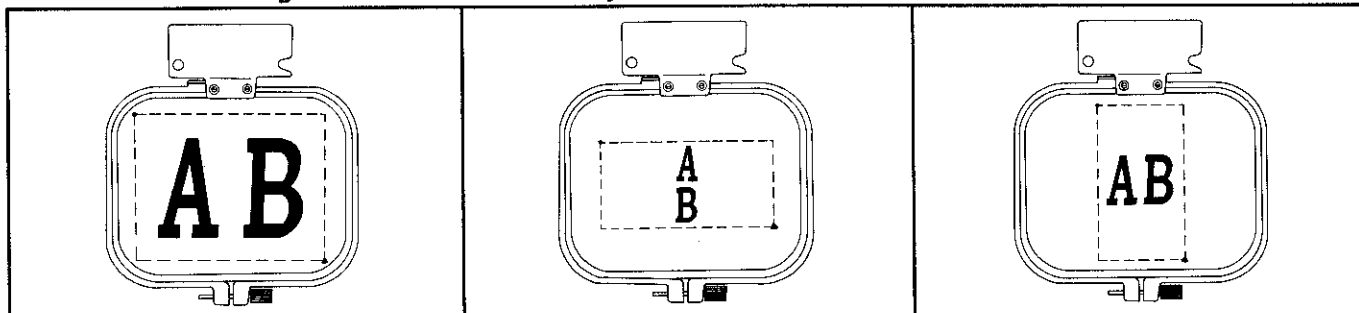

- * 1. Monogram letter size will be set to the largest ratio at which both the length and width can be sewn within the area.
- * 2. Check the automatically calculated size.
Monogram size determined by the automatic calculation mode can be checked. See page 69.

D. Designate dimensions

Specify the dimensions for the monogram

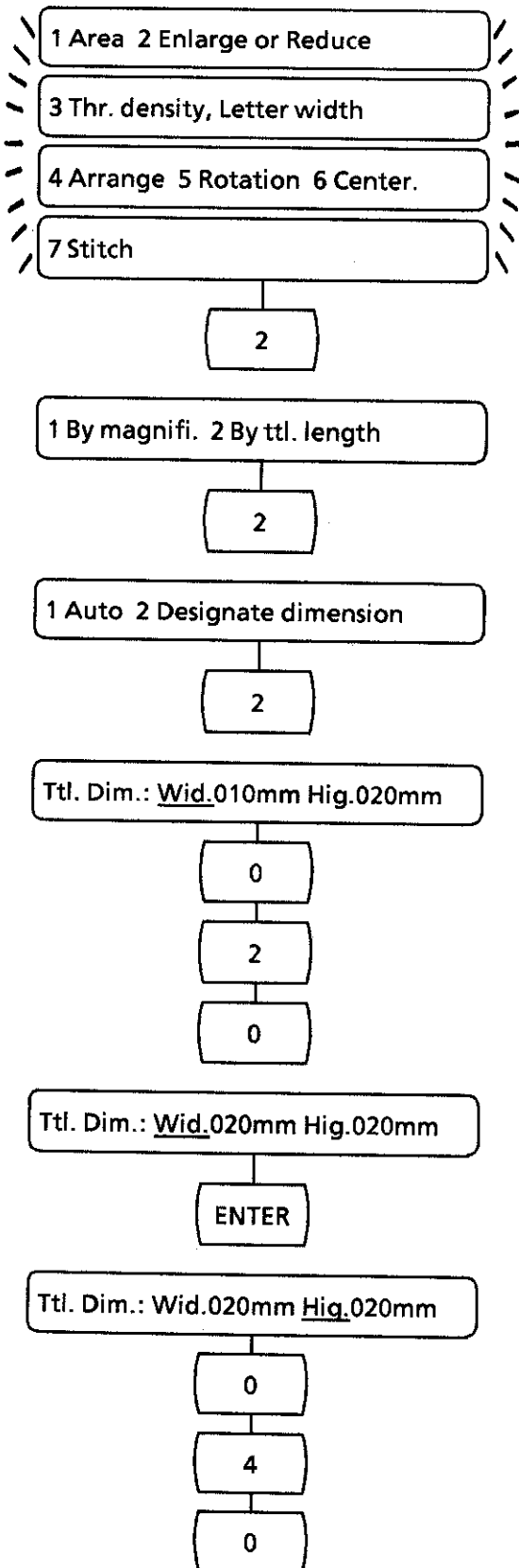

Letters can be enlarged or reduced in 1 mm increments, and the total length (length, width) can be specified for sewing.
NOTE: If the total length equals or exceeds the sewing area, the following will occur.

- 1) The "Short of area" message will be displayed.
- 2) Proper needle starting point location will not be possible by pressing the jog keys <D> <A> while the "Move needle to start point > ent" and the "Area over" messages are displayed alternately. Reset the sewing area so that it is larger than the total length.

1. Press <2> to select [2. Enlarge or Reduce].

2. Press <2> to select [2. By ttl. length].

3. Press <2> to select [2. Designate dimension].
The cursor will be positioned under Wid.

* The total length of the currently displayed characters will be displayed as three digits. If the font is changed or other changes are made after sewing, the displayed value may differ from the length of the previously sewn characters.

Ex Set the total dimensions to Lat. 20 mm and Wid. 40 mm
(area size: Lat. 50 mm and Wid. 50 mm)

1. Press <0><2><0>.

* 1. Dimensions must be a three digit number.

* 2. The total dimensions of the monogram must be within the specified area.

[Wid. 020 mm] will be displayed.

2. Press <ENTER>.

The total length is entered, and the cursor will move under Wid.

3. Press <0><4><0>.

* 1. Dimensions must be a three digit number.

* 2. The total dimensions of the monogram must be within the specified area.

[Lat. 040 mm] will be displayed.

Ttl. Dim.: Wid.020mm Hig.040mm

ENTER

Ttl. Dim.: Wid.020mm Hig.040mm

END

1 Area 2 Enlarge or Reduce

3 Thr. density, Letter width

4 Arrange 5 Rotation 6 Center.

7 Stitch

4. Press <ENTER>.

The total width is entered, and the cursor will move under Hig. again.

5. Press <END >.

The total dimensions for the monogram AB are now set. The edit menus will be alternately displayed.

* A ↑ B.

When (after the magnification of each letter has, by dimension designation, become A (H. 1.0, W. 1.0) ↑ (H. 5.0) B (H. 1.0, W. 1.0) by individual designation) the overall size is increased two times, becoming A (H. 2.0, W. 2.0) ↑ (H. 10.) B (H. 2.0, W. 2.0), the space code magnification will exceed 9.9 even though the letter data only became twice as great, and sewing cannot be done.

* Ttl. Length must fit in sewing area. The same size will be deemed short of area.

6 Thread density and letter width

A. Thread density

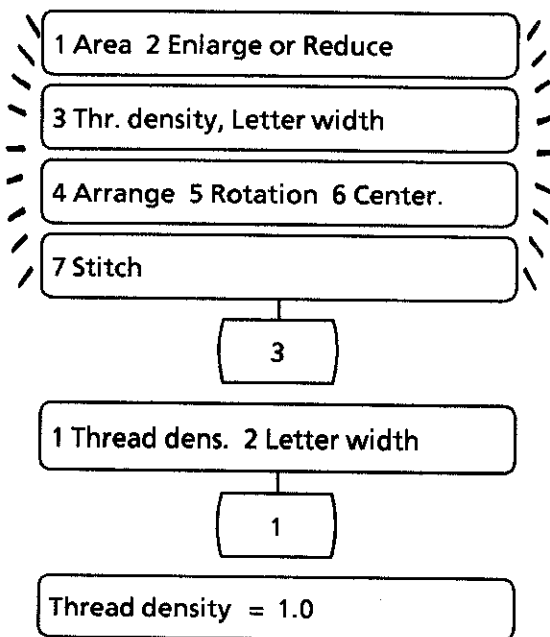

The ratio of the thread density and letter width of the monogram can be changed. This is particularly convenient when sewing small letters.

The thread density ratio of monogram letters can be changed from a minimum of 0.1 to a maximum 2.0 times.

1. Press <3> to select [3. Thr. density, Letter width].
2. Press <1> to select to select [1. Thread dens].
The current thread density ratio will be displayed.
 - * 1. The default setting is 1.0.
 - * 2. If the thread density ratio has already been set, that ratio will be displayed.

Ex Change the thread density to 1.2 times.

<Default>
Heavier 2.0 ← 1.0 → 0.1 Coarser

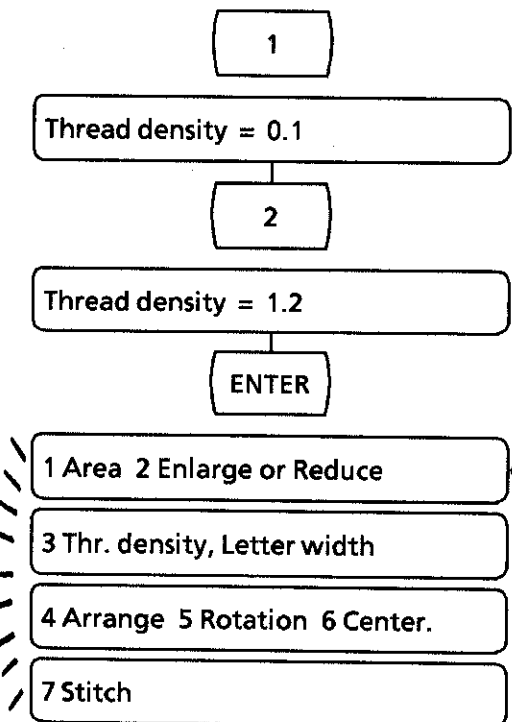

1. Press <1>.
The 0 will be carried and an 1 will appear in the first place.
2. Press <2>.
The 1 will be carried and a 2 will appear in the first place.
3. Press <ENTER>.
The thread density ratio of 1.2 is set.
When the thread density setting is cancelled, press <END>. The messages **Not Changed** and **Press end key** will be displayed alternately.
Press <END> again.
The edit menu will be alternately displayed.
To confirm the edited contents, press <*>. See page 69.
To sew, press <END>. See page 33.

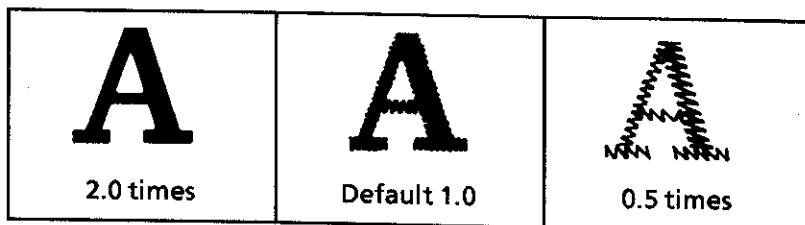

B. Letter width

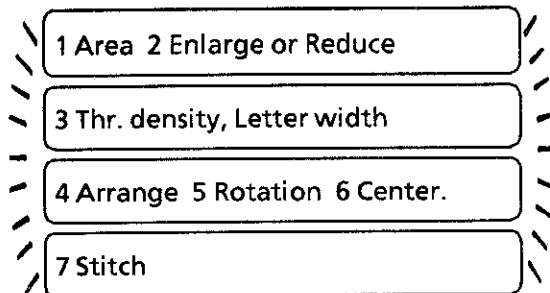

3

1 Thread dens. 2 Letter width

2

Letter width = 1.0

Ex Change the letter width to 1.5 times.

1

Letter width = 0.1

5

Letter width = 1.5

ENTER

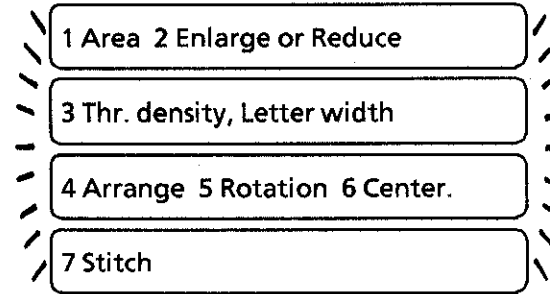

The width ratio of monogram letters can be changed from a minimum of 0.6 to a maximum 2.0 times.

1. Press <3> to select [3. Thr. density, Letter width].

2. Press <2> to select to select [2. Letter width].

The current letter width will be displayed.

* 1. The default setting is 1.0.

* 2. If the letter width has already been set, that setting will be displayed.

<Default>
Bolder 2.0 ← 1.0 → 0.6 Finer

1. Press <1>.

The right 0 will be changed to 1.

2. Press <5>.

The 1 will be moved to the left of the decimal point and the 5 will appear on the right.

3. Press <ENTER>.

The letter width of 1.5 times is set.

When the thread density setting is cancelled, press <END>.

The messages **Not Changed** and **Press end key** will be displayed alternately.

Press <END> again.

The edit menu will be alternately displayed.

To confirm the edited contents, press <*>. See page 69.

To sew, press <END>. See page 33.

* In the case that letter width is decreased to a size smaller than the original width using alphabets style code No.1, the first and end stitches become longer as below.

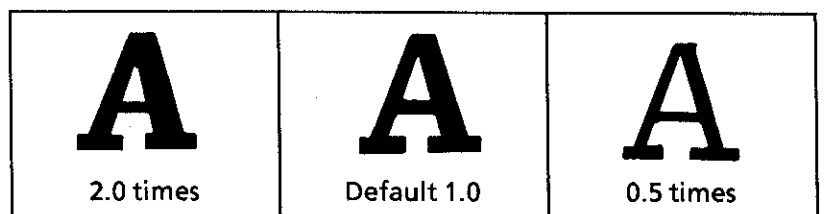

7 Arrange

Letters can be aligned laterally, vertically or on a curve.

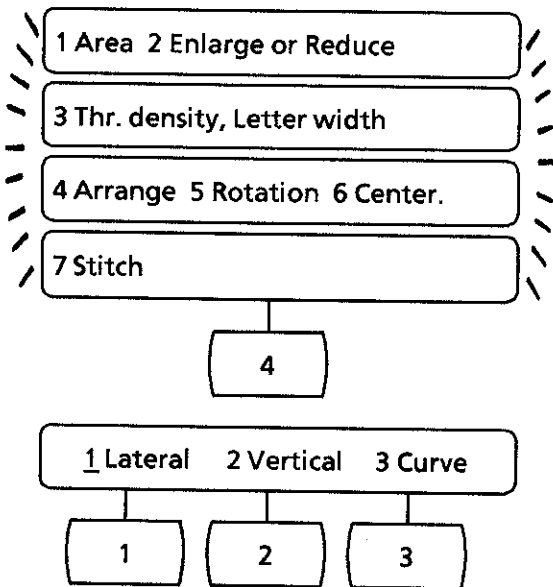

1. Press <4> to select [4. Arrange].
The cursor will be positioned under the current alignment setting.
* The default setting is [1. Lateral].
2. Press <1> to select [Lateral] alignment.
Press <2> to select [Vertical] alignment.
Press <3> to select [Curve] alignment.
Refer to page 58, "Setting a curved monogram."

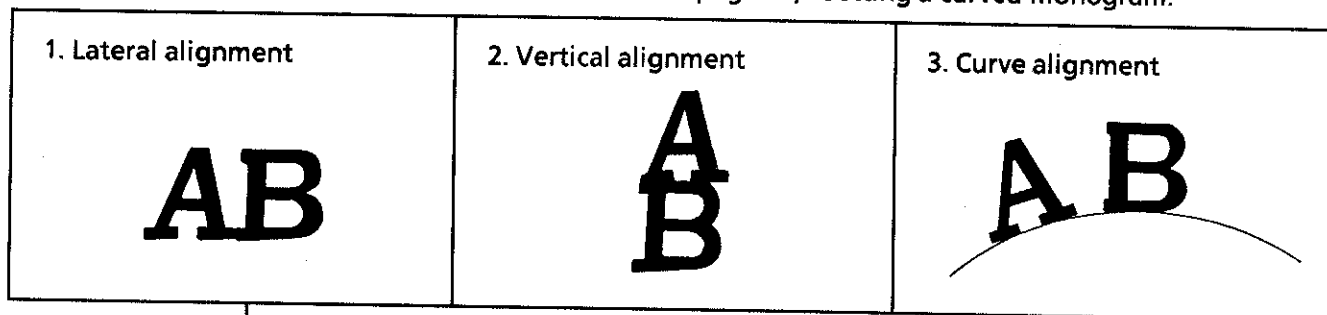

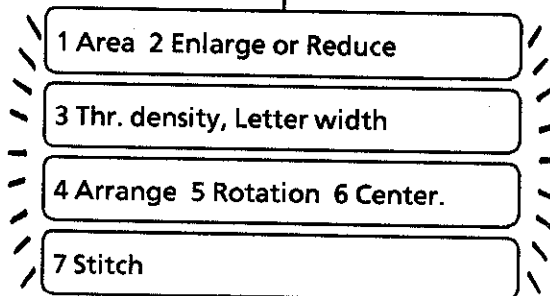

- The edit menu will be alternately displayed.
To confirm the edit contents, press <*>. See page 69.
To sew, press <END>. See page 33.
- * See page 66 for letter positions when lateral alignment is changed to vertical alignment.
 - * In the case to sew small letters such as "f", "g", "j", "p", "q", "y", "z" vertically aligned, those letters overlap with the next letters.

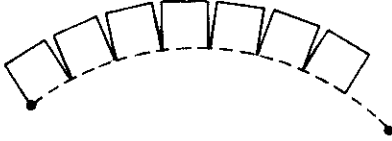
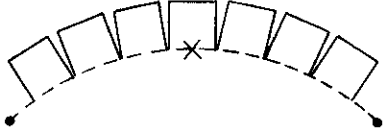
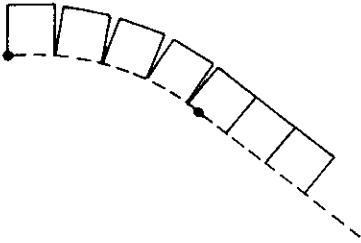
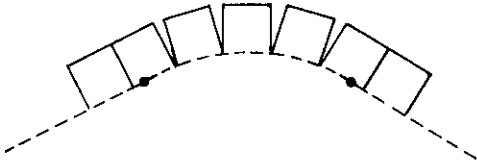
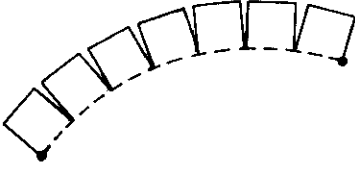

8 Setting a curved monogram

Monogram arrangements such as those shown below can be set depending upon the length of the characters, the length of the curve, and the use of centering. Before selecting the arrangement with edit mode 4, confirm the centering setting, total character length, and individual character length.

No centering	Centering
<p>Total character length < length of curve</p> 	<p>Total character length < length of curve</p> 
<p>Total character length < length of curve</p> 	<p>Total character length < length of curve</p> 
<p>Total character length < length of curve</p> 	<p>Total character length < length of curve</p> 

* A satisfactory alignment may not be obtainable if the "R" (arc) of the set curve is smaller than the size of the letter (if for example, R = 5 mm or less)

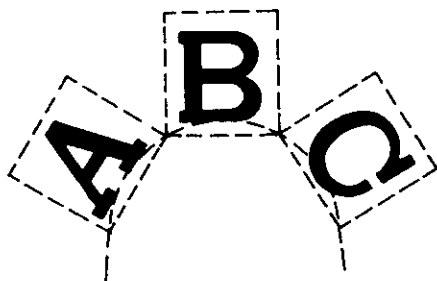

Setting a curved monogram

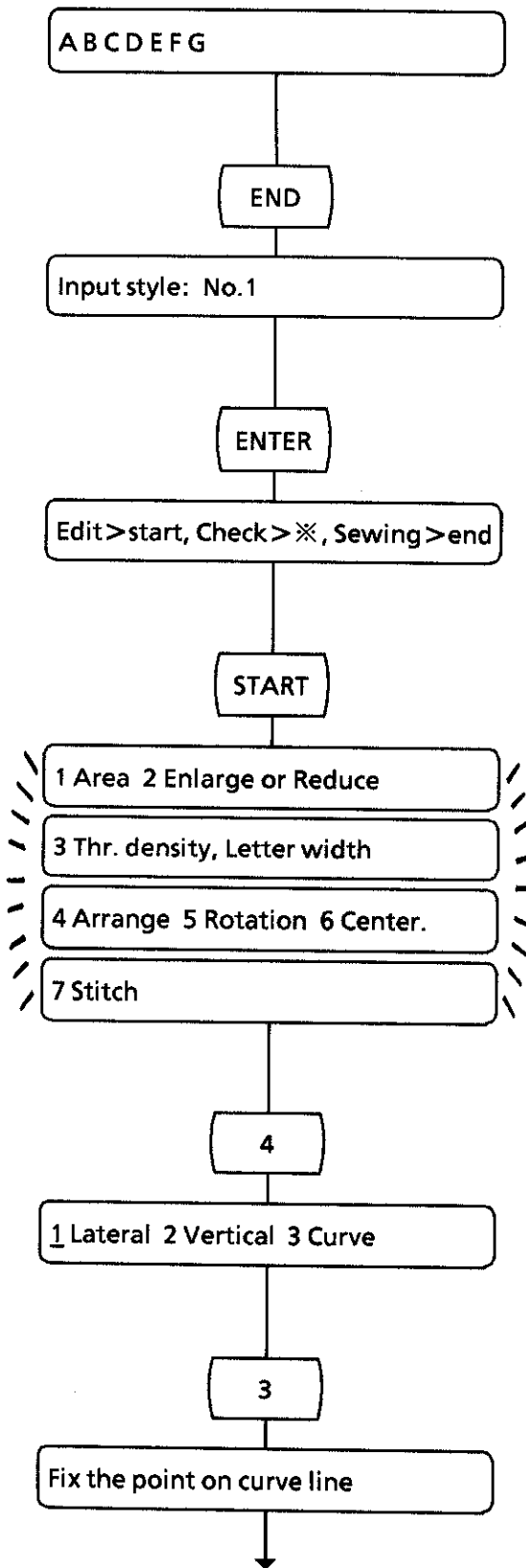

1. In the character input mode, enter the data to be monogrammed on a curve.
2. Press <END>. Also use the number keys to change the font number if desired.
3. Press <ENTER>. To align the entered data precisely to the curve, press <※>.

AB: Width 090 mm Height 015 mm

 will be displayed. Set the length of the curve.
4. Press <START>.
 ※ To change the letters length or size, select <2>, and change the size at this time.
5. Press <4> to select Arrange.
6. Press <3> to select Curve.

Point No.03: x = 063 mm y = 086 mm

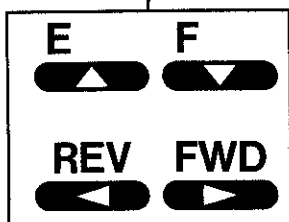

END

Attention moving

Reset > start, Check > *, Edit > end

END

- 1 Area 2 Enlarge or Reduce
- 3 Thr. density, Letter width
- 4 Arrange 5 Rotation 6 Center.
- 7 Stitch

END

Attention moving

Move needle to start point > ent

ENTER

7. Move the needle over the curve with the jog keys, and press <ENTER> to fix points along the curve.

* Determine the length of the curve according to the length of the characters.

8. A curved line is specified by indicating from three to ten points on it. However, when only two points are specified, a straight line which connects them will be specified.

NOTE: No line can be specified if there is only one point.

Then press <END>.

9. To end the curve entry mode, press <END>. Press <※> to trace and confirm the curve. To re-enter the curve, press <START> and return to 7.

※ After setting the curve, you can not use "2. Enlarge or Reduce". If you want to change the size or length, stop setting the curved monogram temporarily, and press <4>. Select "1. Lateral" or "2. Vertical", and change the size or length. Press <4> again, and continue setting the curved monogram. This means in 'Curved monogram' you can not change letter size. If you press <2>, the "Impossible enlarge by lng. > end" message will be displayed.

10. After ending all editing operations, press <END>.

The alarm will sound and the needle will move to the beginning of the curve. If centering is set, the needle will move to the middle of the curve.

※ See page 33, "Sewing".

Setting character rotation on a curve

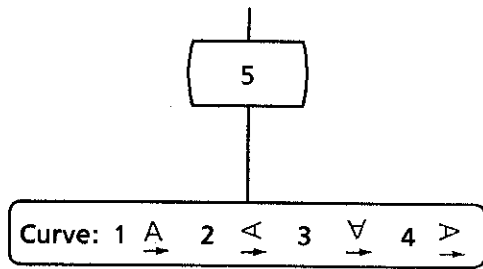

Press <5>.

Set the rotation as for vertical and horizontal writing. Rotation of characters on a curved line will be performed character by character.

If the alarm sounds and [↵ exist on the Curve line > end] or [↵↔↑↓ exist on Curve line > end] is displayed

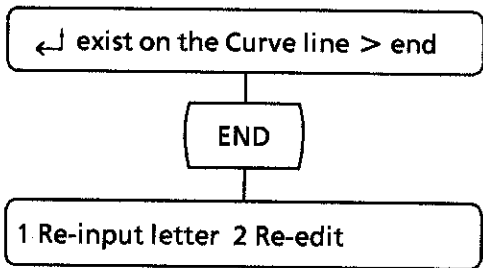

Note: The entered data cannot be sewn along curve if there is a return (↵) code (↔↑↓) included in the data.

1. Press <END>. To delete the ↵.



2. Press <1>. See the following page for the procedure if <2> is pressed.

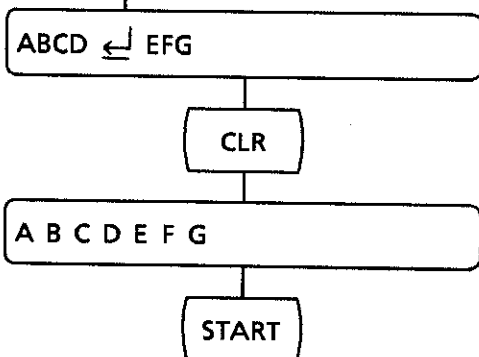
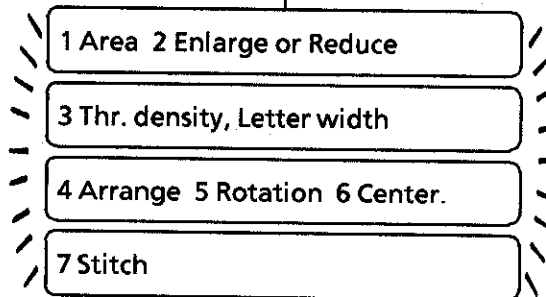

3. Use the <<> and <>> keys to bring the cursor under the ↵, and then press <CLR>.

4. The ↵ was erased.

5. The sewing mode can now be selected and the data sewn along a curve. The curve is already set and need not be set again.

(△▽▷◁)

Like the carriage return key above (↵), the space code keys are also invalid.

When re-editing (cancelling alignment along a curve)

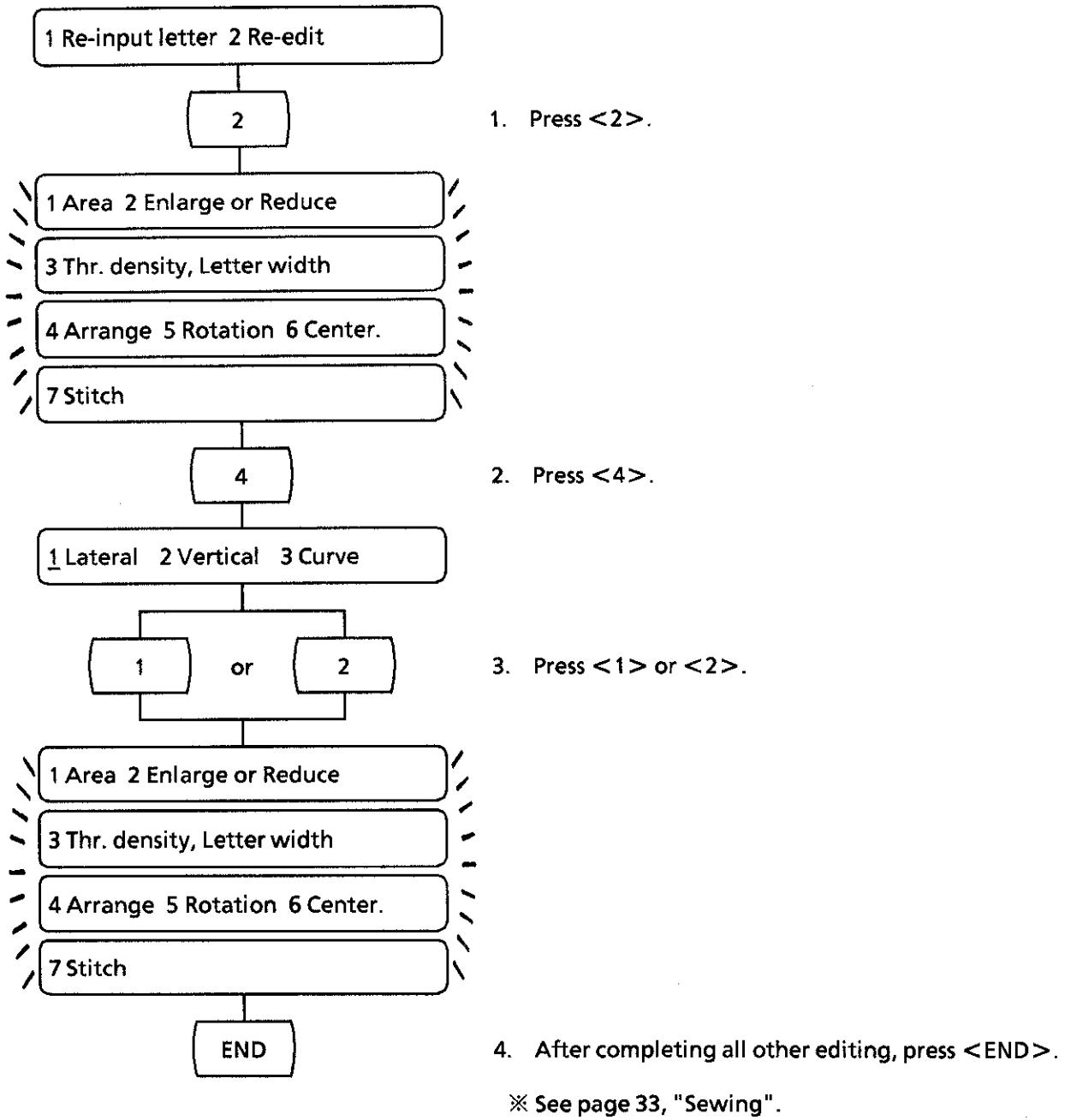

9 Rotation

The monogram can be additionally rotated in 90° steps for either lateral or vertical alignment.

A. If lateral alignment is selected

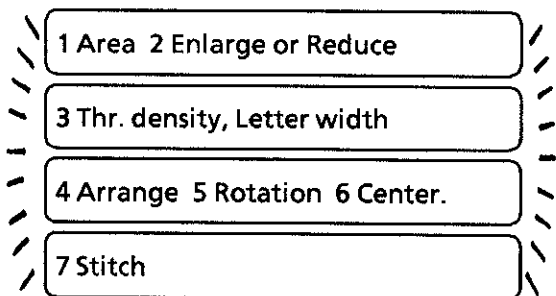

1. Press <5> to select [5. Rotation].

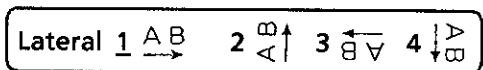

The cursor will be positioned under the current setting.
* The default setting is [1. AB].



2. Press the number 1, 2, 3, or 4 to select the desired lateral rotation.

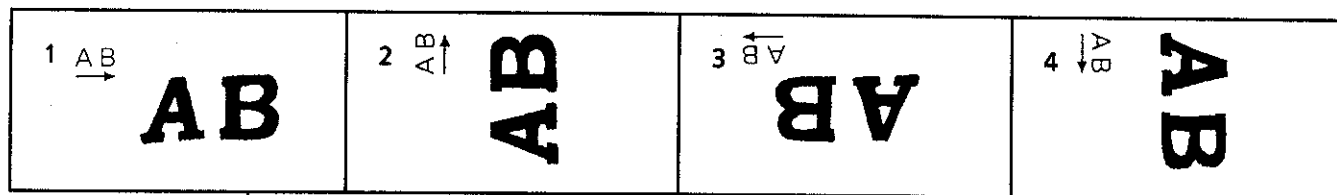

The edit menus will be alternately displayed.
* To sew, press <END>. See page 33.
To confirm the edit contents, press <*>. See page 69.

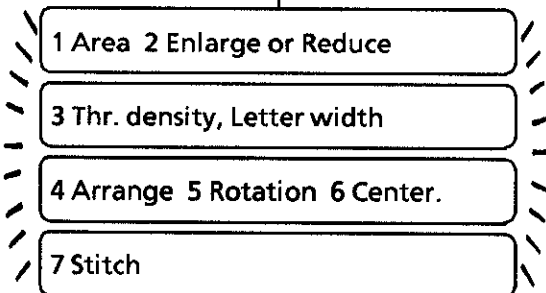

B. If vertical alignment is selected

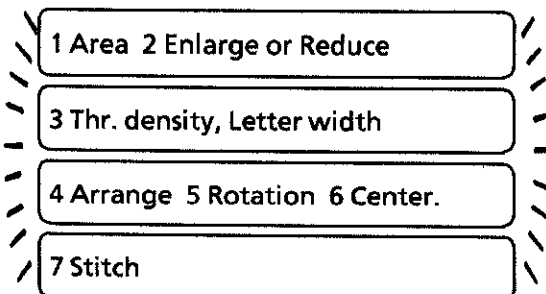

1. Press <5> to select [5. Rotation].

Vertical 1 $\downarrow \begin{matrix} A \\ B \end{matrix}$ 2 $\leftarrow \begin{matrix} B \\ A \end{matrix}$ 3 $\begin{matrix} B \\ A \end{matrix} \uparrow$ 4 $\begin{matrix} B \\ A \end{matrix} \rightarrow$

The cursor will be positioned under the current setting.
* The default setting is [1. AB].



2. Press the number <1>, <2>, <3>, or <4> to select the desired vertical rotation.

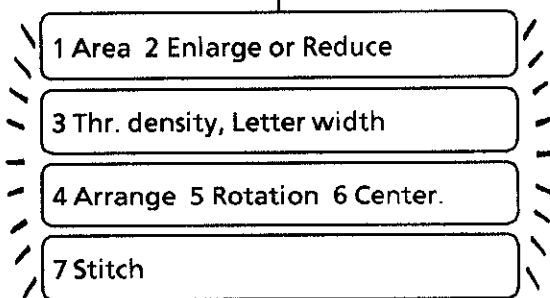
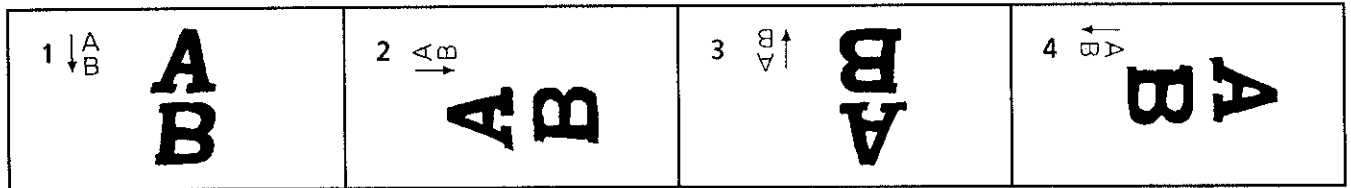

The edit menus will be alternately displayed.

* To sew, press <END>. See page 33.

To confirm the edit contents, press <*>. See page 69.

C. Curve alignment is selected

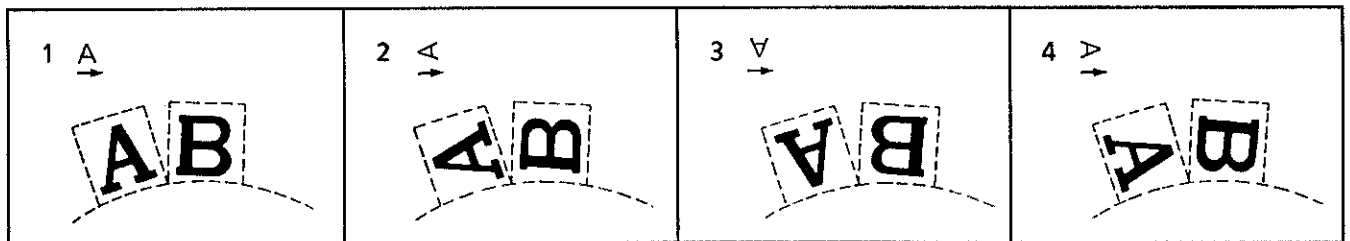

10 Centering

Centering of the monogram can be set or cancelled.

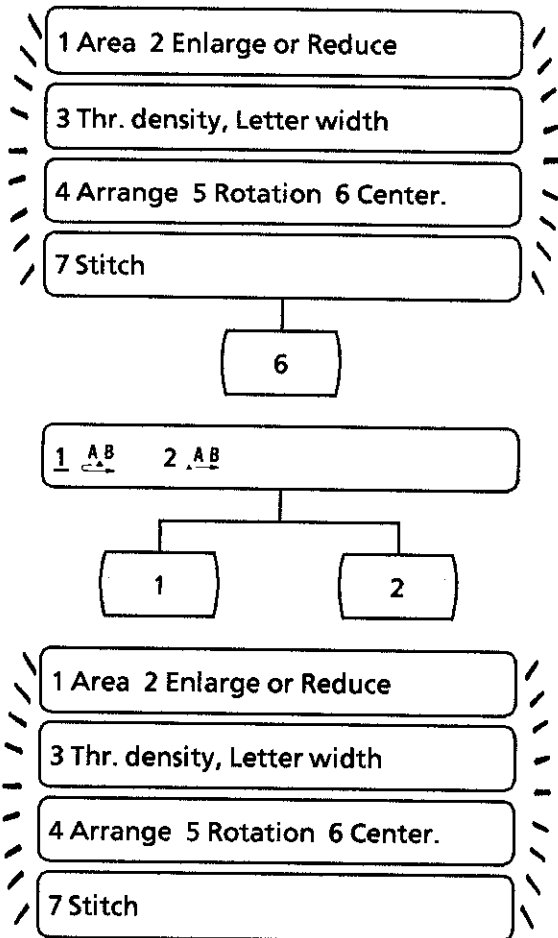

1. Press <6> to select [6. Center].

The cursor will be positioned under the current setting.
* The default setting is [1. AB].

2. To set centering, press <1>.
To cancel centering, press <2>.

The edit menus will be alternately displayed.

* To sew, press <END>. See page 33.
To confirm the edit contents, press <*>. See page 69.

With centering

- Line is not finished using the return code.

Sewing starts regarding the current needle position as the center.

E.g. There are five letters on a line.



This is the needle position when <START> is pressed.

- Lines are finished using the return code.

Sewing starts regarding the current needle position as the center position of the first line. The needle position is the center of the first line at the start of sewing. On and after the second line, lines are aligned with the center of each line of text.

E.g.

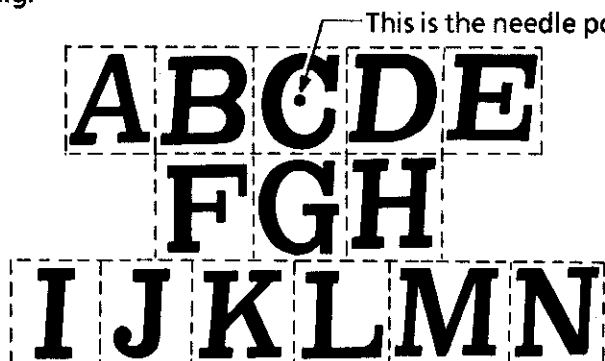

This is the needle position when <START> is pressed.

Without centering

- Line is not finished using the return code.

Sewing starts regarding the current needle position as the left end of the text.

E.g.



This is the needle position when <START> is pressed.

- Lines are finished using the return code.

Sewing starts regarding the current needle position as the left end of the text on the first line, the needle position being considered as being at the left end of the first line at the start of sewing. On and after the second line, the left end of the lines are aligned with the left end of the first line of text.

E.g.

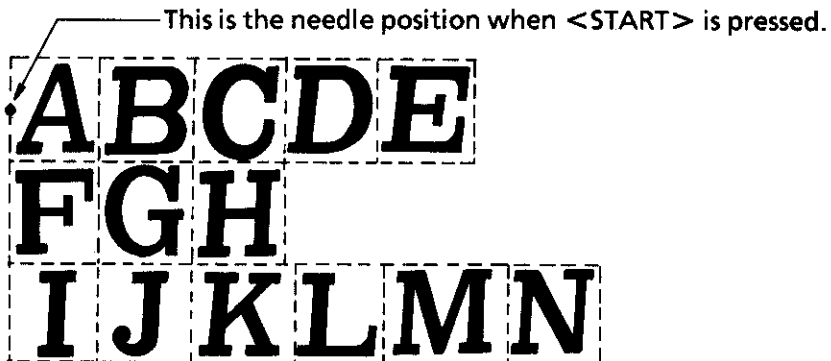

This is the needle position when <START> is pressed.

Setting the needle start position and sewing position
 Refer to this section when setting the needle start position.

Set the monogram AB for lateral positioning.

Rotation Centering	\overrightarrow{AB}	\overleftarrow{AB}	\overleftarrow{AB}	\overrightarrow{AB}
Centering selected	A·B Needle start position	A·B	A·B	A·B
Centering cancelled	A·B Needle start position	A·B	A·B	A·B

Set the monogram AB for vertical positioning.

Rotation Centering	$\downarrow AB$	$\uparrow AB$	$\uparrow AB$	$\downarrow AB$
Centering selected	A B Needle start position	A·B	B·A	A·B
Centering cancelled	A B Needle start position	A·B	B·A	A·B

* The sewing position can be checked with the test mode.

11 Editing item confirmation

The settings of any edit item can be checked.

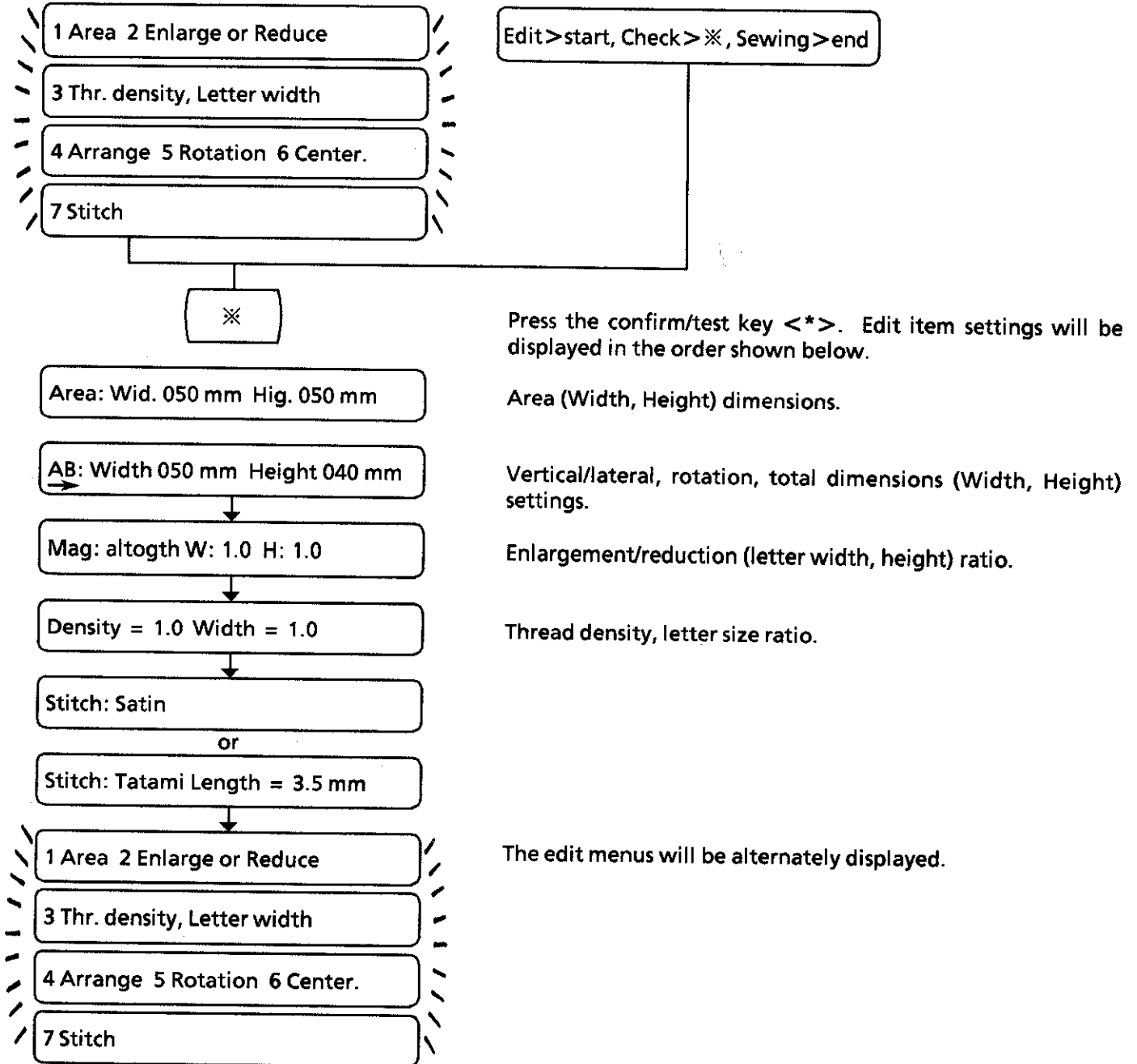

Edit>start, Check>*, Sewing>end

*

Press the confirm/test key <*>. Edit item settings will be displayed in the order shown below.

Area (Width, Height) dimensions.

Vertical/lateral, rotation, total dimensions (Width, Height) settings.

Enlargement/reduction (letter width, height) ratio.

Thread density, letter size ratio.

The edit menus will be alternately displayed.

- * 1. If the total length (Width, Height) is greater than the dimensions of the area (Width, Height), [Short of area] will be displayed. Re-edit.
- * 2. Edit item contents can be confirmed as frequently as desired by simply pressing the confirm/test key <*>.

Default (standard) settings

Edit items can also be reset to the default (standard) settings.

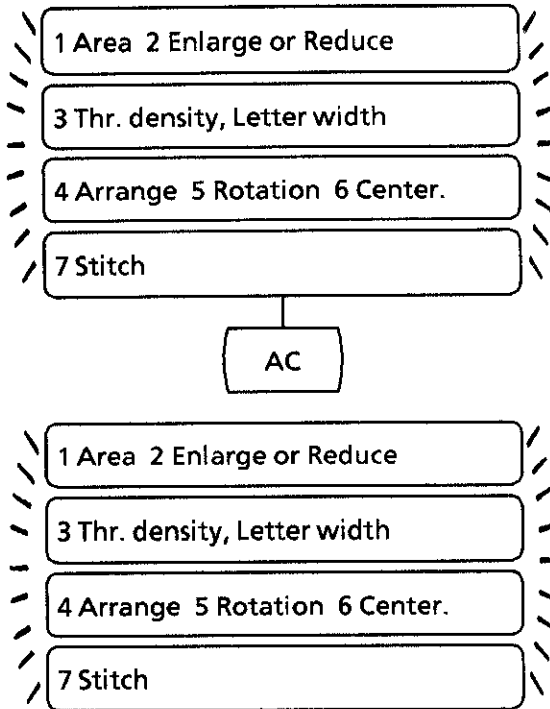

Press <AC>.

All edit items will be reset to the default (standard) settings.

Default values	
Area:	Wid. 120 mm Hig. 100 mm
AB:	Width □□□ mm Height □□□ mm
Ratio:	Width 1.0 Height 1.0
Thread density =	1.0 Letter width = 1.0
Stitch:	Satin

In addition, the centering mode is selected and the centering indicator  will light.

12 Setting the sewing speed

Sewing speed can be changed before sewing or while sewing is suspended.

It can be selected from three levels; slow (500 spm), middle (800 spm), and fast (1000 spm).

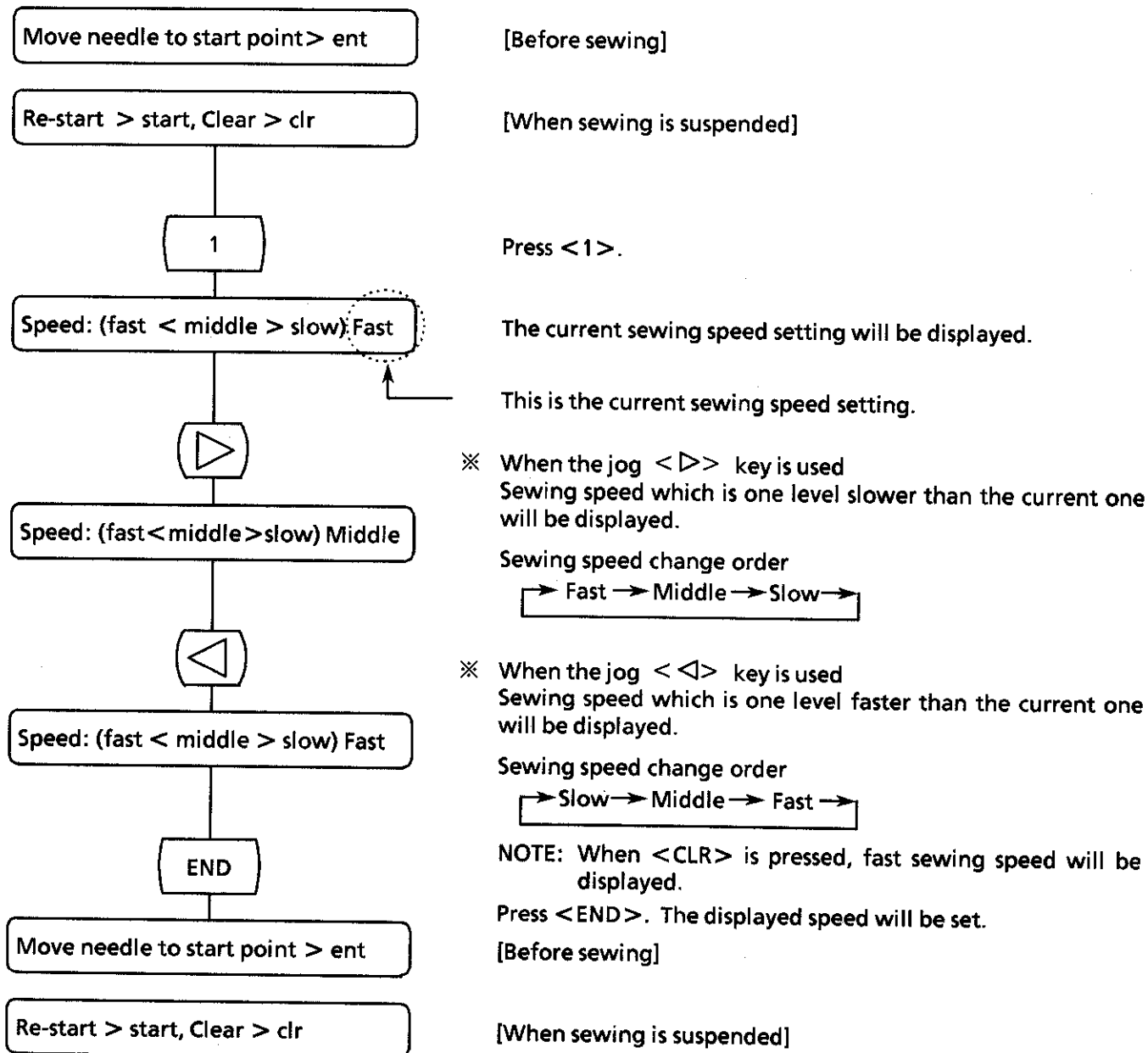

Stitch length and sewing speed

	Stitch length (mm)					
	0.1 - 2.9	3.0 - 3.4	3.5 - 4.4	4.5 - 5.5	5.6 - 7.3	7.4 - 12.7
Fast	1000 rpm	650 rpm	500 rpm	400 rpm	300 rpm	150 rpm
Middle	800 rpm	500 rpm	400 rpm	300 rpm	150 rpm	150 rpm
Slow	500 rpm	400 rpm	300 rpm	150 rpm	150 rpm	150 rpm

13 Tatami stitching

Tatami stitching

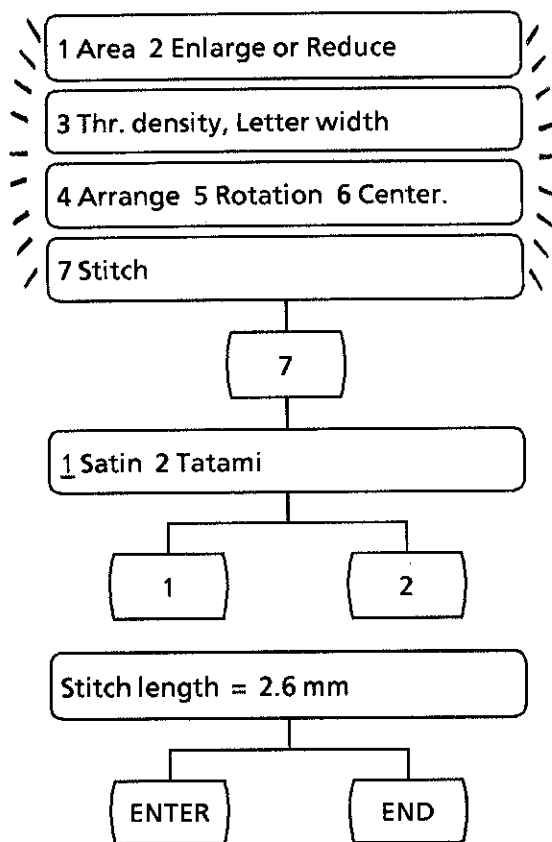

1. Press <7>.

2. Press <2> to sew in the tatami mode.
Press <2> to sew in the tatami mode.

Enter the tatami pitch with the number keys, and set with <ENTER>.

The range is from 2.0 to 9.9 mm in 0.1 mm increments.
The standard is 2.6 mm.

If you want to cancel tatami stitch setting, press <END>.
The messages **Not Changed** and **Press end key** will be displayed alternately. Press <END> again.

14 Storing character data on disk (creating a storage disk)

Patterns can be stored on 3.5" floppy disk.
 Up to 40 patterns can be stored on a single disk.
 Registration numbers for patterns are FF01 to FF40.
 Be sure to use Brother disks.

After entering the character codes and completing all editing tasks, set the sewing start point with the jog keys, and then press <ENTER>.

Messages will be alternately displayed.

When <END> is pressed

Step 1.

Messages will be alternately displayed.

Insert the disk to which the pattern is to be stored.

Replace with Memory Disk

This message will appear when a memory disk is not inserted after pressing <5>.

Insert the memory disk.

Displayed if there is insufficient space on the disk.

Press any key.

Memory over

Press <5>.

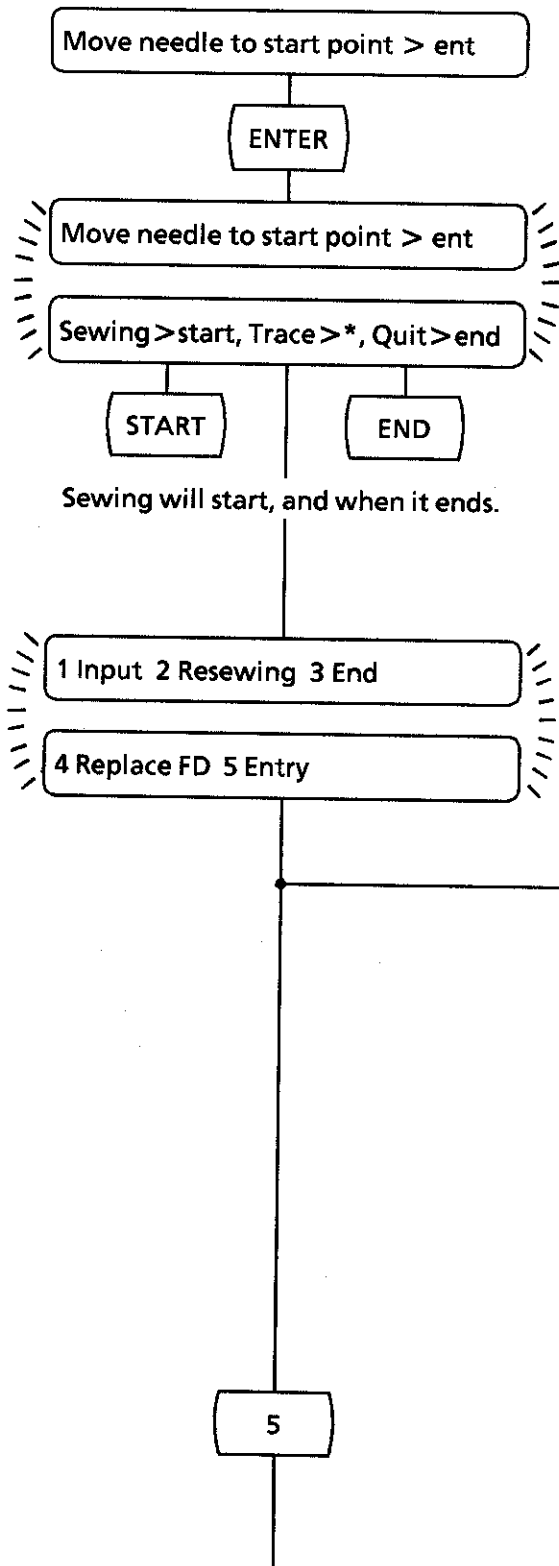

1 New entry 2 Re entry

1. New entry
Used when automatically entering new patterns successively from FF01. Normally use this mode.
2. Re entry
Used when modifying a pattern, for example to change a pattern stored as F10. The pattern stored under that title will be erased when it is rewritten.

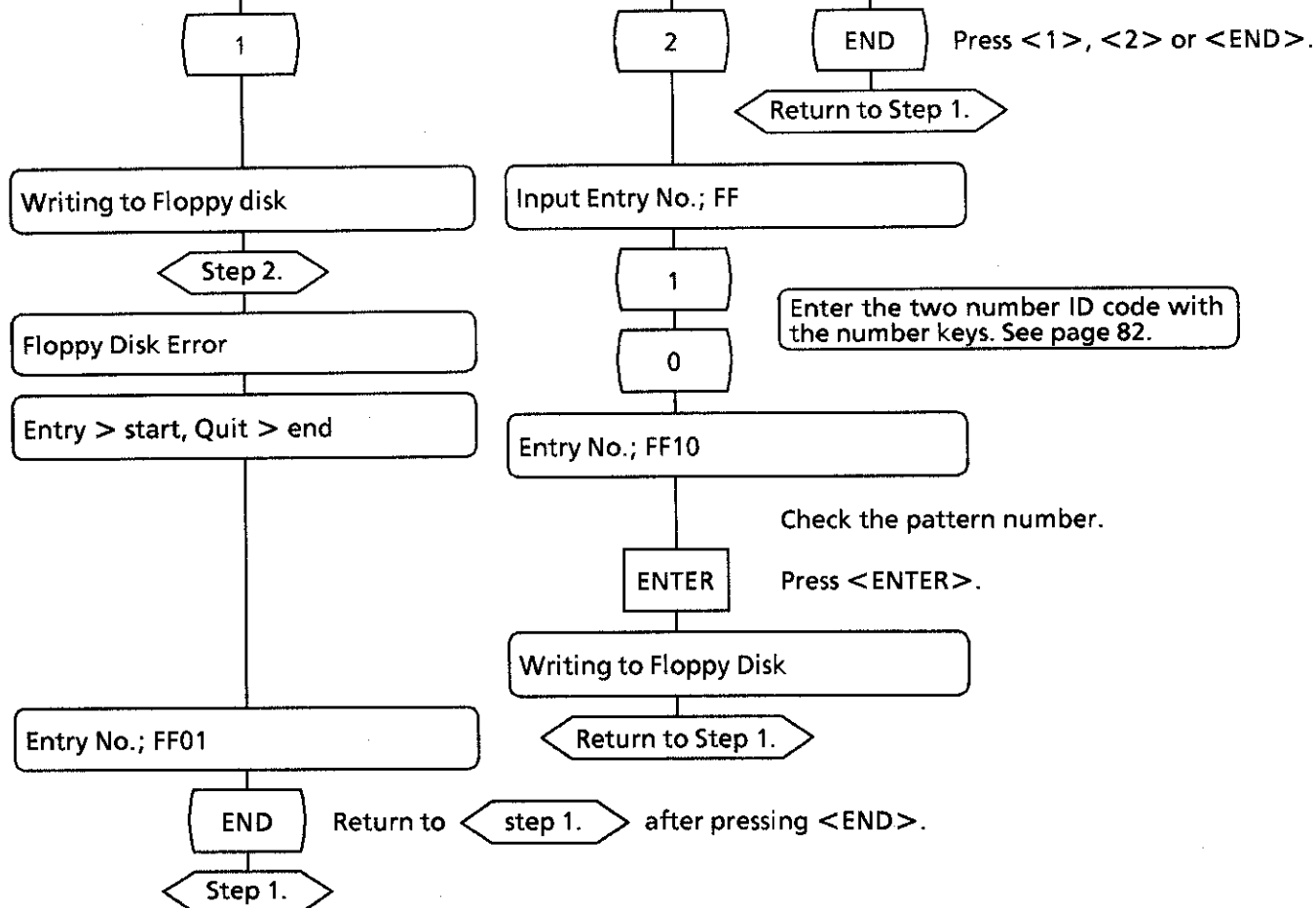

At Step 2.

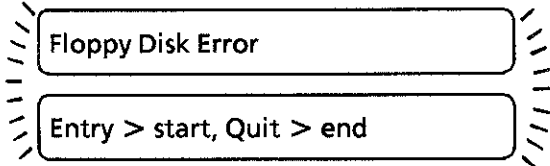

These messages will be alternately displayed. Check the following and then press <START>.
 Note: A disk error will always be displayed the first time a new disk is used. Press <START> anyway. The disk will be automatically formatted and the pattern will be stored.

- Check**
1. If the disk is protected, slide the protect tab up so that it covers the hole, and press <START>.
 2. If the disk is a Brother character data disk, replace it with a disk for pattern storage, and press <START>.
 3. If a disk for pattern storage is used for the first time, or if the disk has been used on a different system, press <START>.
 4. Pattern can not be stored other than in the above cases. Press <END>.

15 Reading character data

At the text code entry step (See page 20.)

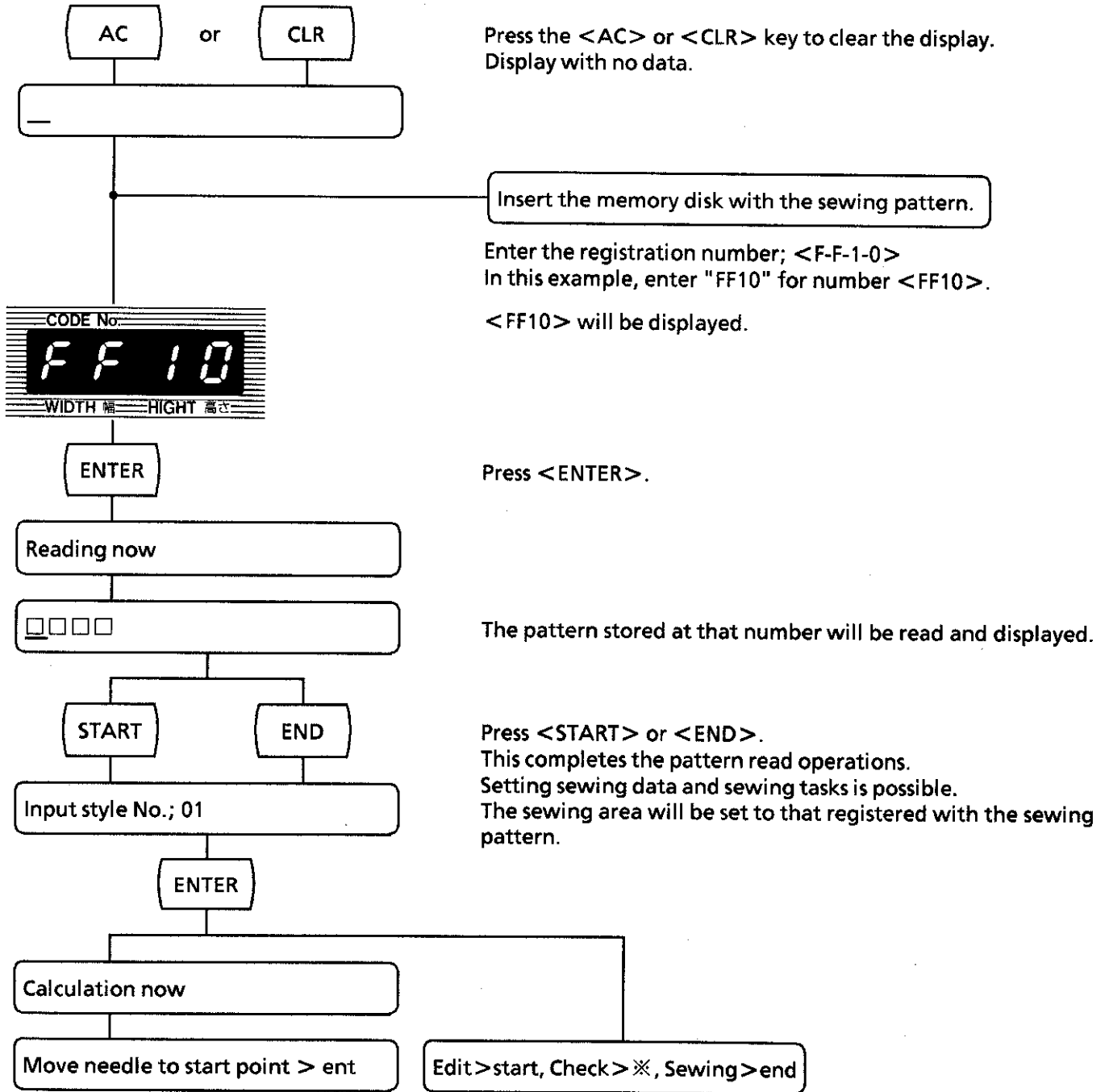

Example

To add new data (Ex. a name; "SMITH") to a previously stored pattern, e.g. BROTHER.

Use the operation panel on the sewing machine to enter the pattern code for the pattern to be read from the disk.

At the text entry step (See page 20.)

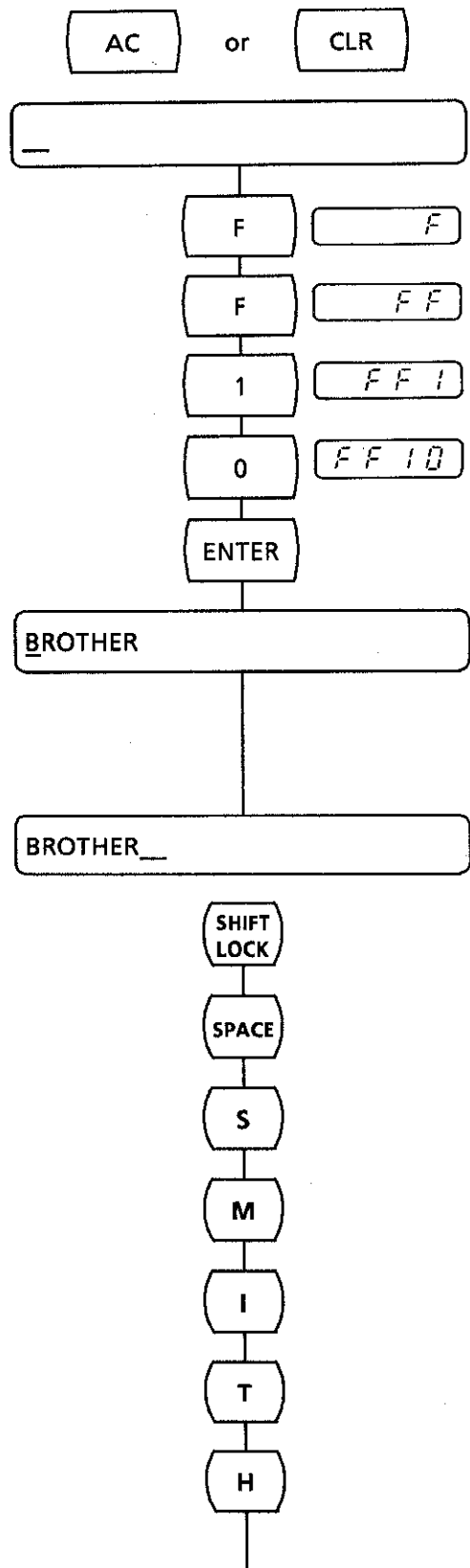

Press the <AC> or <CLR> key to clear the display.

Insert the disk containing the pattern to be used.

Enter the number of the pattern (assumed here to be FF10).
The registration number will be displayed: FF10.

Press <ENTER>.

Press <D> on the machine panel, and move the cursor to the right of "R".

The pattern stored under that name will be read.

To add new information (Ex. the name "SMITH") to existing data, use the keyboard.

Enter the letters for "SMITH".

Press <SHIFT LOCK>.

Press <SPACE>.

Press <S>.

Press <M>.

Press <I>.

Press <T>.

Press <H>.

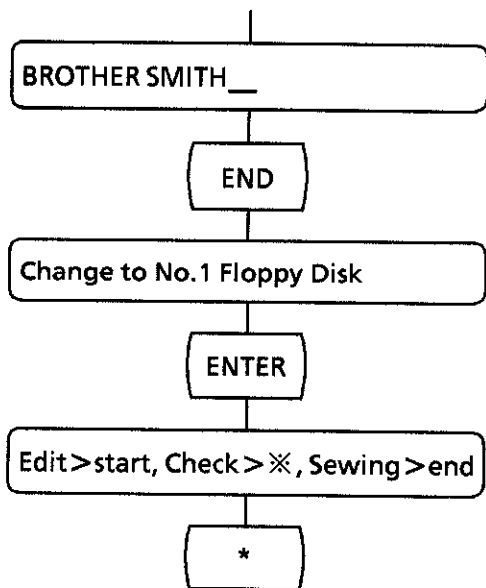

Press <END>.

This message will be displayed.
Remove the disk and insert disk 01.

When data stored in the memory disk has been enlarged or reduced in the individual size ratio mode, its edited contents should be reset. The appended data will be automatically set to the standard magnification; 1.0.

Press <*> to check the magnification and area before sewing.

If [Disk error] is displayed or blank characters are displayed after <END> is pressed, check if that disk is the desired data disk (disk No.1), and then press <END> again.

If [Disk error] is still displayed, refer to error messages, page 80.

OPTIONAL PARTS

1 Sub table

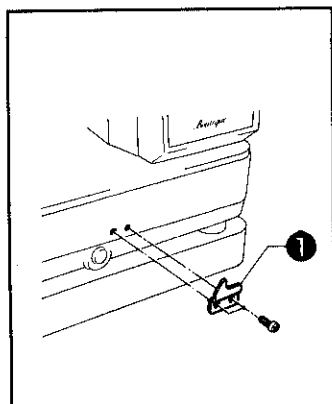

1. Attach guide pin support F ① to the machine using the two screws.

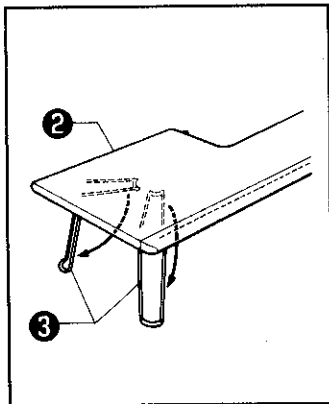

2. Extend the legs ③ of the sub table ②.

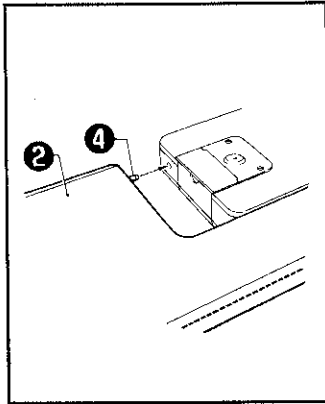

3. Insert the guide pin ④ into the hole in the machine by slightly lifting up the sub table ②.

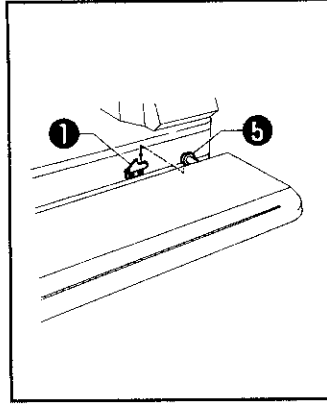

4. Lower the guide pin ⑤ onto guide pin support F ①. Remove the sub table in the reverse order.

2 Spring

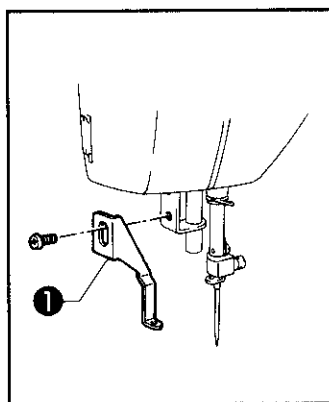

1. Turn the pulley to set the needle bar to its lowest position. Remove the screw, and the presser foot ①.

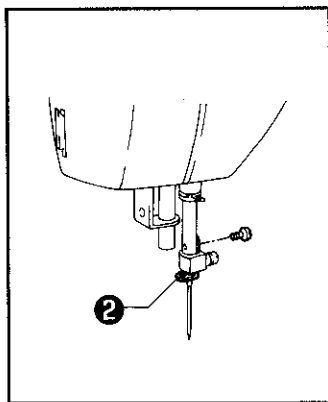

2. Remove the screw from the needle bar thread guide ②.

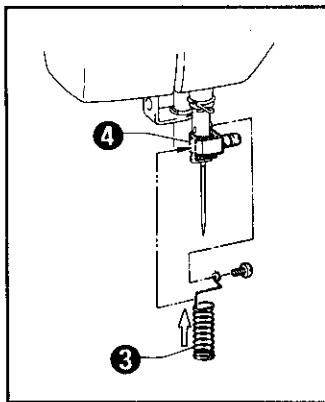

3. Pass the needle through the spring ③. Hook the spring onto the needle clamp ④, and secure it using the screw.

NOTE: Bend the spring. Adjust the spring position so that it is centered around the needle.

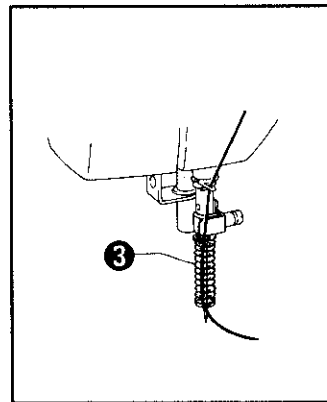

4. Pass the thread through the spring as shown in the figure above.

3 Bobbin thread sensor

Attachment

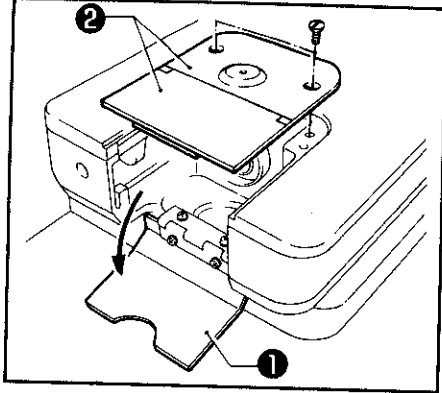

1. Open the needle plate side cover ①. Remove the screw, the needle, and the slide plate ②.

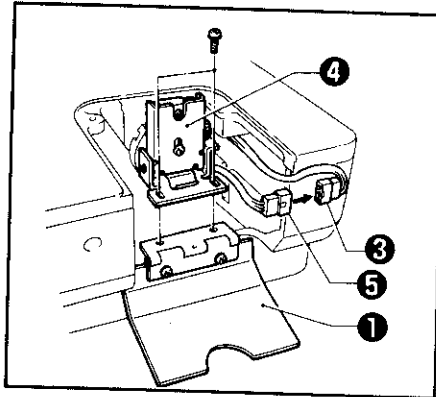

2. Attach the connector ③ on the machine bottom, to the connector ⑤ of the bobbin thread sensor ④. Remove the two screws from the needle plate side cover ②, and attach the needle plate side cover ② and the bobbin thread sensor ④ using the two removed screws.

NOTE: The bobbin thread sensor should not contact the bobbin case.

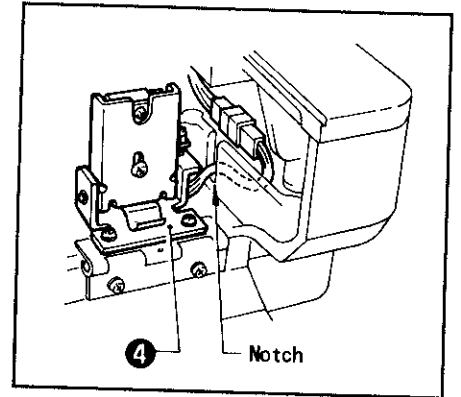

3. Pass the bobbin thread sensor ④ cord through the notch in the bottom machine cover, and insert it all the way to the bottom.

Adjustment

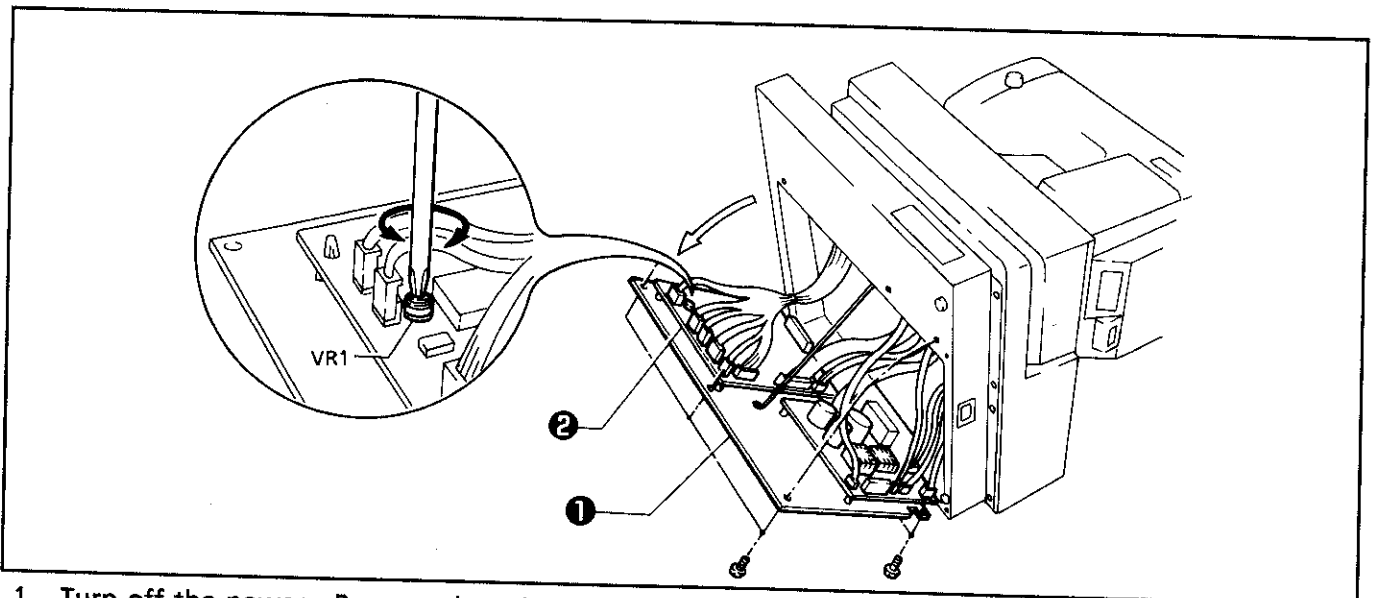

1. Turn off the power. Remove the printed circuit board, and adjust the knob VR1 on the main circuit board using a screwdriver so that it can rotate smoothly.

NOTE: Tilt the machine head with its front facing up until it stops. Remove the three upper screws on the printed circuit board, loosen the three lower screws, and remove the printed circuit board. At this time, the machine may be unsteady. Be sure to secure the machine. When removing the printed circuit board, make sure that connectors on it are securely attached.

2. Wind about 10 m of spun thread #100 around the bobbin.

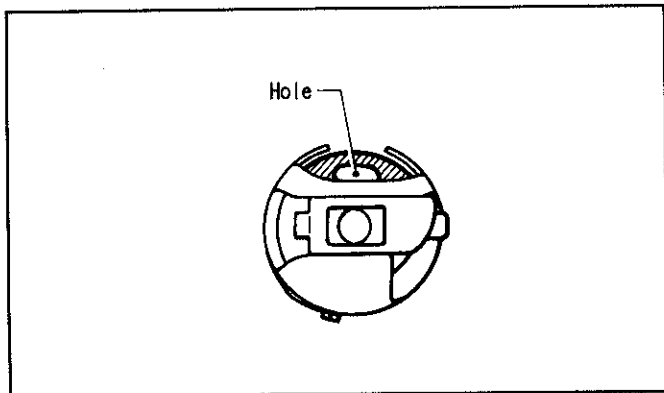

3. Set the bobbin so that its hole can be seen from the hole in the bobbin case.

4. Set the bobbin thread sensor so that it is kept vertical, and close the needle plate side cover.

5. While pressing the <START> and <ENTER> keys on the key panel at the same time, turn on the power.

The message, "Start at test mode" will appear on the screen.

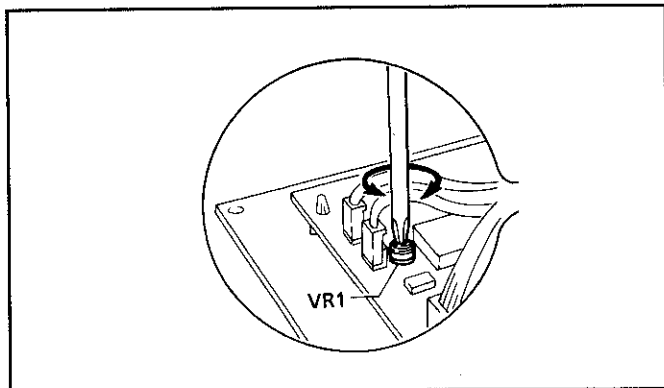

6. Fully turn knob VR1 on the main circuit board counterclockwise.

7. Press the <A> key on the key panel. The message, "Test: thread remainder sensor" will appear on the screen.

NOTE: If you press any of keys <1> to <9>, the pulley will turn.

8. Turn knob VR1 slightly clockwise, and press the <A> key.

If the bobbin thread LED has not lit up, turn the knob VR1 slightly clockwise, and press the <A> key again.

Adjust the knob VR1 by repeating it until the LED lights up.

9. Turn off the power. Attach the printed circuit board using the screw.

- If the bobbin thread sensor LED is not lit, adjust the bobbin thread sensor position as follows.

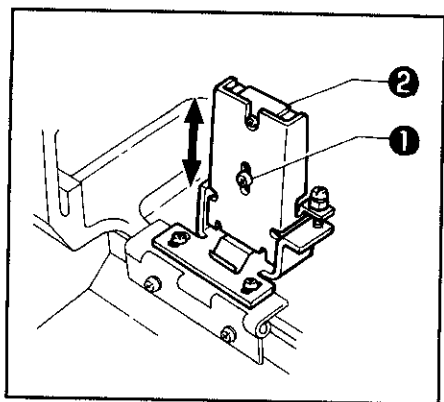

1. Loosen the screw ①, and adjust the height of the bobbin thread sensor ② by moving it up or down.

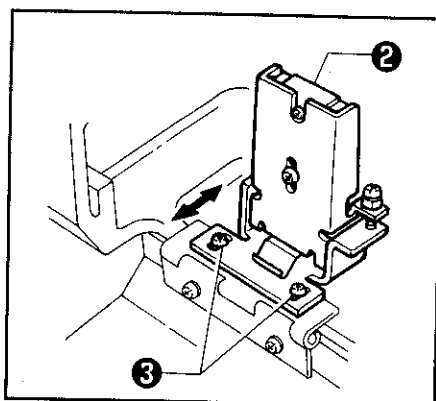

2. Loosen the two screws ③, and adjust the back and front position of the sensor ② by moving it back and forth.

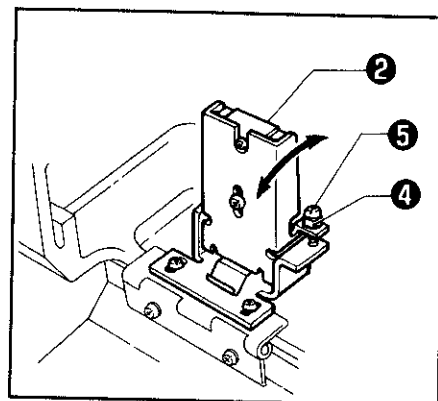

3. Loosen the nut ④. Adjust the horizontal position of the sensor ② by turning the screw ⑤. Tighten the screw ⑤ to raise the sensor ②; loosen the screw ⑤ to tilt the sensor toward the bobbin case.

TROUBLESHOOTING

If there seems to be a malfunction, first try to diagnose the problem referring to the table below. If the problem persists and cannot be resolved, turn the power switch off and contact your dealer.

	Problem	What to check
Check once more.	1. Power switch is on but display does not come on.	1. Is the display contrast properly adjusted?
	2. A floppy disk is in the drive but the indicator does not light.	1. Is the disk damaged?
	3. Thread breakage.	1. Is the machine properly threaded? 2. Is the thread tension too high? 3. Is the rotary hook assembly clogged? 4. Is there thread on the bobbin? 5. Is the needle bent? 6. Is there a gouge in or rough edge on the needle plate, rotary hook, or bobbin case that might cut the thread?
	4. Needle strikes the embroidery hoop.	1. Is the area specification properly set? 2. Is the embroidery hoop too small?
	5. Bobbin thread cannot be wound.	1. Is the rubber roller worn?
	6. Needle breaks.	1. Are the needle direction and height properly adjusted? 2. Is the needle bent? 3. Is the needle tip blunt?
	7. Monogram letters are not properly sewn.	1. Is the material edge catching on the edge of the machine? (Are the embroidery hoop and other parts operating correctly?)

If the backup memory contents are erased (e.g., in the case the machine is left unused for an extended period), items 8-2 and 8-3 below may occur.

	Problem	What to check
Check once more.	<p>8-1. Jog keys are pressed but the needle position does not change.</p> <p>8-2. During area specification, the needle position does not change even though the jog keys are pressed (hoop does not move).</p> <p>8-3. During setting of the needle start position, the needle position does not change even though a jog key(s) is pressed (hoop does not move).</p>	<p>The jog keys can only be used under the following conditions to adjust the needle position. Pressing the jog keys at any other time has no effect.</p> <ul style="list-style-type: none"> • During editing in the 1. Area selection when: <ul style="list-style-type: none"> Designate point on upper left is displayed, or Designate point on lower right is displayed. • When setting the needle start position before starting sewing, and: <ul style="list-style-type: none"> Move needle to start point > ent is displayed, or Area over and Move needle to start point > ent are alternately displayed. • Sewing > start, Trace > ✖, Quit > end and Move needle to start point > ent are alternately displayed. • When you set the area after you aligned characters on a curve, if the curve is out of the area, the needle does not move. Please reset the area or change the arrangement. <p>1. Turn the power switch off, press <START> and <CLR> simultaneously, and turn the power switch on again. (This clears the backup memory.)</p> <p>1. Press <END> and reset the area in the edit mode.</p> <p>2. Turn the power switch off, press <START> and <CLR> simultaneously, and turn the power switch on again. (This clears the backup memory.)</p>

ERROR MESSAGES

Refer to the table below when an error message is displayed.

Message	Cause	Solution
Short of area	The total sewing length exceeds the area.	Press <END>, and either change the area, size ratio, or rotation, or re-enter the monogram letters.
Floppy Disk Error	The disk is damaged. Replace the disk.	Press any key. If the display does not go out, turn the power switch off and then on again. If the display still does not go out, contact your dealer.
Memory over - Letter	Memory capacity overflow.	Press <END>, and re-enter the letters or edit the monogram. (See p.21 to re-enter, p.46 to edit.)
Letter dimension over area	The entered value exceeds the range of 4 mm - 120 mm.	Press <START>, and re-enter the correct value. (See p.41 for dimension specification.)
Letter over area	Area specification is inappropriate. Stop motion assembly is loose.	Reset the area. (See p.42.) Tighten the stop motion assembly.
Thread breakage	1. Upper thread breakage. 2. Thread is not wound onto the thread breakage detector. 3. Bobbin thread breakage or bobbin thread has run out.	Press <END>, thread the needle thread, reverse the needle several stitches, and press <START> to re sew, or press <END> and cancel sewing. Wrap the needle thread around the thread breakage detector and press <START> to re sew, or press <END> and cancel sewing. Remove the bobbin, fill it, and reset.
Impossible detect point x	Damaged circuit board, disconnected cable, or short.	Contact your dealer.
Impossible detect point y	Pulse motor problem, disconnected cable, or short. Blown fuse.	
Over Load	Pulley is too tight. The needle thread is wound onto the pulley, making it hard to turn. Thread is wound around the rotary hook assembly. Motor problem. Blown fuse on the circuit board. Enlargement/reduction ratio exceeds 0.1 - 9.9.	Remove the load or thread from around the pulley. Remove the thread. Contact your dealer. Press <END>. The previously entered value appears, and the machine is returned to the editing mode.
Data error - Letter	Error in the data.	Replace the floppy disk. Contact your dealer.
Not Changed	When a Tajima disk is indicated to be used but a different kind of disk is inserted.	Insert the Tajima disk, and press <END>.
Memory over	Data volume of the Tajima disk is too large.	Press <END>, and input another pattern.

CHARACTER CODE LIST

English Alphabet

CHARACTER Code		CHARACTER Code	
A	41	a	61
B	42	b	62
C	43	c	63
D	44	d	64
E	45	e	65
F	46	f	66
G	47	g	67
H	48	h	68
I	49	i	69
J	4A	j	6A
K	4B	k	6B
L	4C	l	6C
M	4D	m	6D
N	4E	n	6E
O	4F	o	6F
P	50	p	70
Q	51	q	71
R	52	r	72
S	53	s	73
T	54	t	74
U	55	u	75
V	56	v	76
W	57	w	77
X	58	x	78
Y	59	y	79
Z	5A	z	7A

European Type

CHARACTER Code		CHARACTER Code	
Å	80	ú	9E
Ä	81	á	9F
Ü	82	í	A0
β	83	ó	A1
Ç	84	Õ	A4
Ö	85	ã	A5
Ñ	86	õ	A6
Æ	87	ì	A7
ø	88	ì	A9
å	89	ò	AA
â	8A		
à	8B		
ä	8C		
<u>a</u>	8D		
ï	8E		
î	8F		
û	90		
ù	91		
ü	92		
ê	93		
è	94		
é	95		
ë	96		
ô	97		
ö	98		
<u>o</u>	99		
ñ	9A		
ç	9B		
æ	9C		
Ø	9D		
Å	A3		

SYMBOLS

CHARACTER Code		CHARACTER Code	
•	2E	*	7F
:	3A	0	2A
?	3F	1	30
!	21	2	31
—	2D	3	32
/	2F	4	33
"	22	5	34
&	26	6	35
'	27	7	36
(28	8	37
)	29	9	38
~	7E		39

Underlines can also be used in the monogram

CHARACTER Code	
Font code	02
~	A2

Space Code

CHARACTER Code	
↑	1C
↓	1D
→	1E
←	1F

※ Space codes cannot be used to place arrows in the monogram.
These are used to adjust the space the between characters.

FLOPPY DISK INPUT CONTENTS LIST

NUMBER	INPUT CONTENTS	NUMBER	INPUT CONTENTS
FF-01		FF-21	
FF-02		FF-22	
FF-03		FF-23	
FF-04		FF-24	
FF-05		FF-25	
FF-06		FF-26	
FF-07		FF-27	
FF-08		FF-28	
FF-09		FF-29	
FF-10		FF-30	
FF-11		FF-31	
FF-12		FF-32	
FF-13		FF-33	
FF-14		FF-34	
FF-15		FF-35	
FF-16		FF-36	
FF-17		FF-37	
FF-18		FF-38	
FF-19		FF-39	
FF-20		FF-40	

