

LK3-B448E / BA-16

INSTRUCTION MANUAL

ELECTRONIC LOCKSTITCH BUTTON SEWER WITH BUTTON FEEDER

Please read this manual before using the machine.

Please keep this manual within easy reach for quick reference.

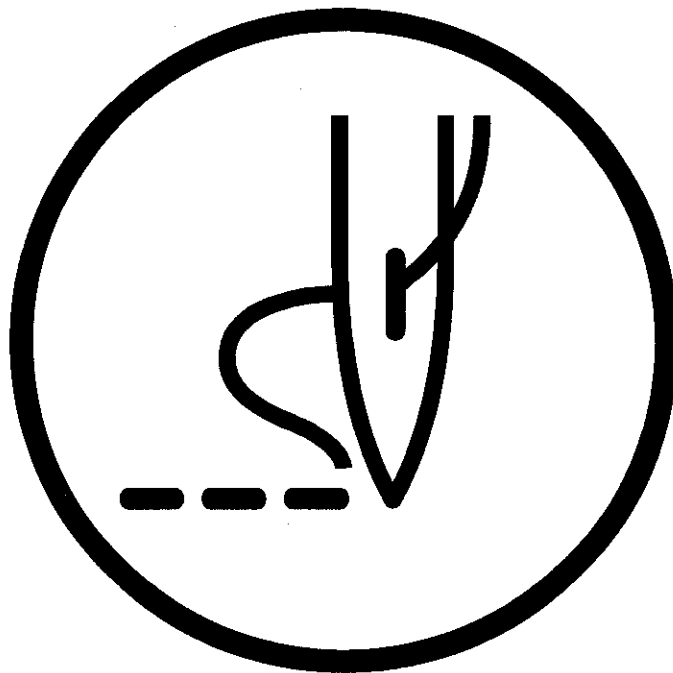

brother[®]



Thank you very much for buying a BROTHER sewing machine. Before using your new machine, please read the safety instructions below and the explanations given in the instruction manual.



With industrial sewing machines, it is normal to carry out work while positioned directly in front of moving parts such as the needle and thread take-up lever, and consequently there is always a danger of injury that can be caused by these parts. Follow the instructions from training personnel and instructors regarding safe and correct operation before operating the machine so that you will know how to use the machine correctly.

SAFETY INSTRUCTIONS



1 Safety indications and their meanings

This instruction manual and the indications and symbols that are used on the machine itself are provided in order to ensure safe operation of this machine and to prevent accidents and injury to yourself or other people. The meanings of these indications and symbols are given below.



Indications

 DANGER	The instructions which follow this term indicate situations where failure to follow the instructions will almost certainly result in death or severe injury.
 CAUTION	The instructions which follow this term indicate situations where failure to follow the instructions could cause injury when using the machine or physical damage to equipment and surroundings.

Symbols

 This symbol () indicates something that you should be careful of. The picture inside the triangle indicates the nature of the caution that must be taken.
(For example, the symbol at left means "beware of injury".)

 This symbol () indicates something that you must not do.

 This symbol () indicates something that you must do. The picture inside the circle indicates the nature of the thing that must be done.
(For example, the symbol at left means "you must make the ground connection".)

2 Notes on safety

DANGER



- Wait at least 5 minutes after turning off the power switch and disconnecting the power cord from the wall outlet before opening the face plate of the control box. Touching areas where high voltages are present can result in severe injury.

CAUTION

Installation



- Machine installation should only be carried out by a qualified technician.



- Contact your Brother dealer or a qualified electrician for any electrical work that may need to be done.



- The sewing machine weighs more than 47 kg. The installation should be carried out by two or more people.



- Do not connect the power cord until installation is complete, otherwise the machine may operate if the foot switch is depressed by mistake, which could result in injury.



- Hold the machine head with both hands when tilting it back or returning it to its original position.

Furthermore, after tilting back the machine head, do not push the face plate side or the pulley side from above, as this could cause the machine head to topple over, which may result in personal injury or damage to the machine.



- Be sure to connect the ground. If the ground connection is not secure, you run the risk of receiving a serious electric shock.



- All cords should be secured at least 25 mm away from any moving parts. Furthermore, do not excessively bend the cable or secure it too firmly staples, otherwise there is the danger that fire or electric shocks could occur.



- Install the belt covers to the machine head and motor.



- If using a work table which has casters, the casters should be secured in such a way so that they cannot move.



- Be sure to wear protective goggles and gloves when handling the lubricating oil and grease, so that they do not get into your eyes or onto your skin, otherwise inflammation can result. Furthermore, do not drink the oil or eat the grease under any circumstances, as they can cause vomiting and diarrhoea. Keep the oil out of the reach of children.



- Avoid setting up the sewing machine near sources of strong electrical noise such as high-frequency welding equipment. If this precaution is not taken, incorrect machine operation may result.

Sewing



- This sewing machine should only be used by operators who have received the necessary training in safe use beforehand.



- The sewing machine should not be used for any applications other than sewing.



- Attach all safety devices before using the sewing machine. If the machine is used without these devices attached, injury may result.



- Turn off the power switch at the following times, otherwise the machine may operate if the foot switch is depressed by mistake, which could result in injury.

- Threading
- When replacing the bobbin and needle
- When not using the machine and when leaving the machine unattended



- Do not touch any of the moving parts or press any objects against the machine while sewing, as this may result in personal injury or damage to the machine.



- If using a work table which has casters, the casters should be secured in such a way so that they cannot move.



- If an error occurs in machine operation, or if abnormal noises or smells are noticed, immediately turn off the power switch. Then contact your nearest Brother dealer or a qualified technician.



- If the machine develops a problem, contact your nearest Brother dealer or a qualified technician.

CAUTION

Cleaning



- Turn off the power switch before starting any cleaning work, otherwise the machine may operate if the foot switch is depressed by mistake, which could result in injury.



- Be sure to wear protective goggles and gloves when handling the lubricating oil and grease, so that they do not get into your eyes or onto your skin, otherwise inflammation can result.
Furthermore, do not drink the oil or eat the grease under any circumstances, as they can cause vomiting and diarrhoea.
Keep the oil out of the reach of children.

Maintenance and inspection



- Maintenance and inspection of the sewing machine should only be carried out by a qualified technician.



- Ask your Brother dealer or a qualified electrician to carry out any maintenance and inspection of the electrical system.



- Turn off the power switch and disconnect the power cord from the wall outlet at the following times, otherwise the machine may operate if the foot switch is depressed by mistake, which could result in injury.

- When carrying out inspection, adjustment and maintenance
- When replacing consumable parts such as the rotary hook and knife



- If the power switch needs to be left on when carrying out some adjustment, be extremely careful to observe all safety precautions.



- Hold the machine head with both hands when tilting it back or returning it to its original position.
Furthermore, after tilting back the machine head, do not push the face plate side or the pulley side from above, as this could cause the machine head to topple over, which may result in personal injury or damage to the machine.



- Use only the proper replacement parts as specified by Brother.



- If any safety devices have been removed, be absolutely sure to re-install them to their original positions and check that they operate correctly before using the machine.



- Any problems in machine operation which result from unauthorized modifications to the machine will not be covered by the warranty.

3 Warning labels

★ The following warning labels appear on the sewing machine.

Please follow the instructions on the labels at all times when using the machine. If the labels have been removed or are difficult to read, please contact your nearest Brother dealer.

1

	⚠ DANGER Hazardous voltage will cause injury. Turn off main switch and wait 5 minutes before opening this cover.	⚠ GEFAHR Hochspannung verletzungsgefahr! Bitte schalten sie den hauptschalter aus und warten sie 5 minuten, bevor sie diese abdeckung öffnen.	⚠ DANGER Un voltage non adapté provoque des blessures. Eteindre l'interrupteur et attendre 5 minutes avant d' ouvrir le capot	⚠ PELIGRO Un voltaje inadecuado puede provocar las heridas. Apagar el interruptor principal y esperar 5 minutos antes de abrir esta cubierta.
	(This block contains the detailed text from the warning label above)			

2

⚠ CAUTION	
	Moving parts may cause injury. Operate with safety devices. Turn off main switch before threading, changing bobbin and needle, cleaning etc.

3  • Be sure to connect the ground. If the ground connection is not secure, you run the risk of receiving a serious electric shock.

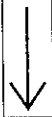
4  • Direction of operation

Safety devices:

- ① Belt cover,
- ② Thread take-up cover,
- ③ Eye guard,
- ④ Motor cover, etc.

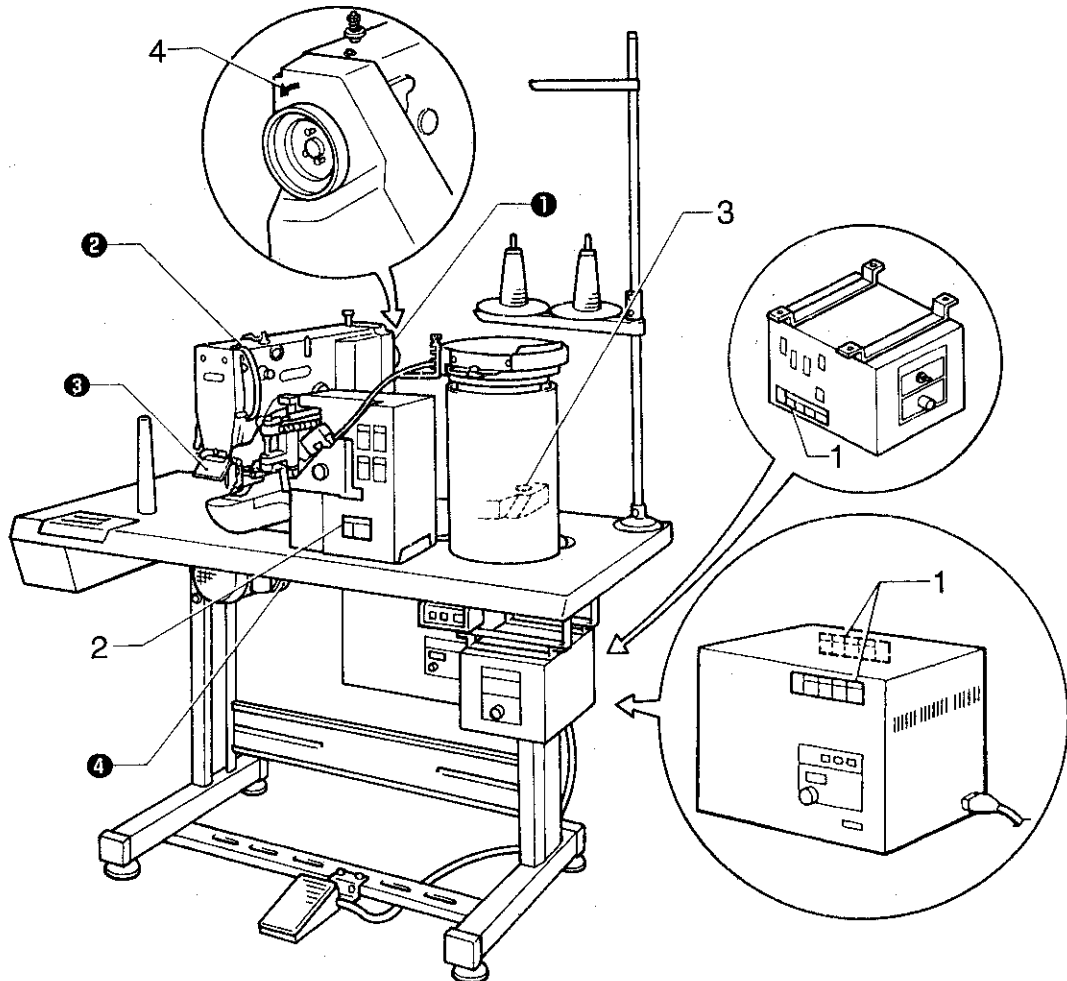

CONTENTS

1. NAME OF EACH PART	1
2. SPECIFICATIONS	2
2-1. Specifications	2
2-2. Program list	3
2-3. Optional parts	5
3. INSTALLATION	6
3-1. Power table	6
3-2. Installing the motor	7
3-3. Installing the motor pulley	7
3-4. Installing the control box	8
3-5. Installing the rubber cushions	9
3-6. Installing the oil pan	9
3-7. Installing the cushions	9
3-8. Installing the machine head	10
3-9. Installing the head rest	10
3-10. Installing the vibrating bowl	11
3-11. Installing the control box (for vibrating bowl)	11
3-12. Installing the button feeder	11
3-13. Connecting the cords	12
3-14. Installing the button feeder cover	14
3-15. Installing the V-belt	15
3-16. Installing the belt cover	15
3-17. Installing the foot switch	16
3-18. Installing the motor cover	16
3-19. Installing the spool stand	16
3-20. Installing the shooter	17
4. LUBRICATION	18
4-1. Lubrication points	18
4-2. Applying grease	18
5. OPERATION	19
5-1. Name and function of each operation panel item	19
5-2. Operating procedure	20
6. CHECKING THE SEWING PATTERN	21
7. CORRECT USE	22
7-1. Selecting the needle and thread	22
7-2. Installing the needle	22
7-3. Threading the upper thread	22
7-4. Winding the lower thread	23
7-5. Replacing the bobbin case and threading the thread	24
7-6. Thread tension reference guide	24
7-6-1. Lower thread tension	24
7-6-2. Upper thread tension	24
7-6-3. Thread takeup spring height	25
7-6-4. Thread takeup spring tension	25

7-7. Operating the vibrating bowl	26
7-8. Adjusting the vibrating bowl	26
7-9. Operating the panel switches (button feeder)	27
7-10. Button replacement	28
7-10-1. Adjustment when the button diameter is changed	28
7-10-2. Adjustment when the button thickness changes	29
7-10-3. If button hole arrangements differ	29
7-10-4. Adjusting the button carrier plate	29
7-10-5. Adjusting the feeder position	30
7-10-6. Adjusting the needle location	31
8. SEWING	32
9. MAINTENANCE AND INSPECTION	33
9-1. Cleaning the rotary hook	33
9-2. Lubrication	33
9-3. Draining the oil	34
9-4. Cleaning the control box air inlet port	34
9-5. Cleaning the eye guard	34
9-6. Checking the needle	34
10. STANDARD ADJUSTMENTS	35
10-1. Adjusting the needle bar height	35
10-2. Adjusting the needle bar lift amount	35
10-3. Adjusting the driver needle guard	36
10-4. Adjusting the needle clearance	36
10-5. Adjusting the shuttle race thread guide	36
10-6. Adjusting the movable knife	37
10-7. Adjusting the button clamp lift amount	38
10-8. Adjusting the holding pressure	38
10-9. Adjusting the button clamp height	39
10-10. Adjusting the thread wiper	40
10-11. Adjusting the needle up stop position	40
10-12. Checking the input sensors	41
10-13. Checking the input voltage	41
10-14. Moving stitch patterns	42
11. CHANGING FUNCTIONS USING THE DIP SWITCHES	43
11-1. Operation panel DIP switches	43
11-2. Setting the presser mode	43
11-3. DIP switches inside the control box	44
11-4. Using user programs	45
• Recording a user program	45
• Using a user program	46
• Clearing the user programs	46
12. CHANGING THE MODE OF THE HANDY SWITCH (OPTION)	47
13. CHANGING SPECIAL FUNCTIONS USING THE MEMORY SWITCHES	48
14. LIST OF ERROR CODES	50
15. ADJUSTMENT GUIDE WHEN DIFFERENT BUTTONS ARE USED	51
16. TROUBLESHOOTING	52

1. NAME OF EACH PART

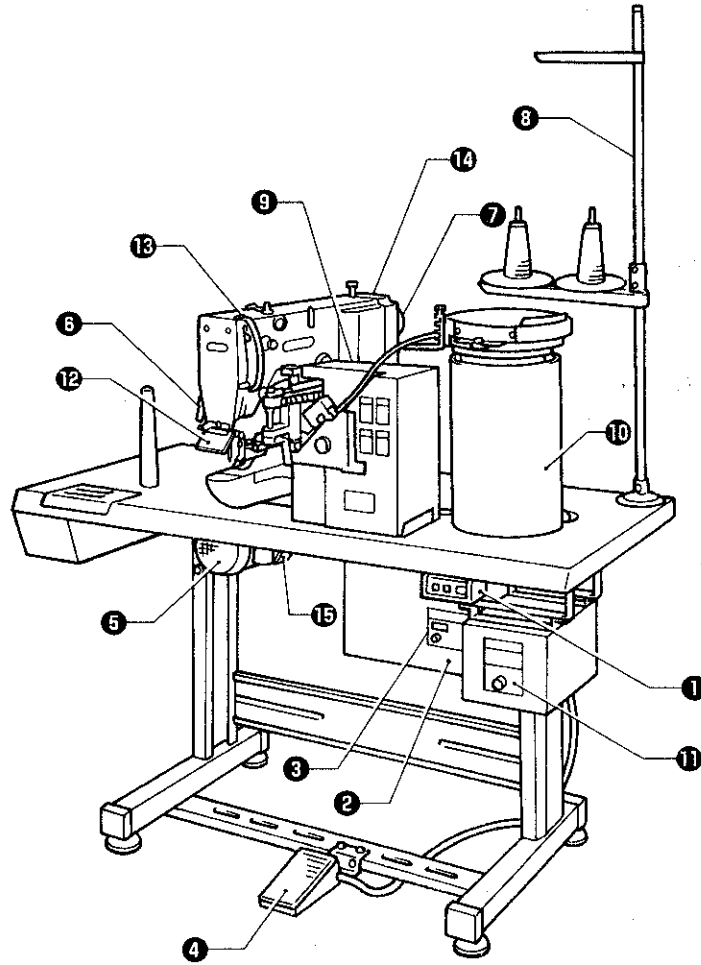

- | | | | |
|-----------------|-------------------------|-------------------|---------------|
| ❶ Power switch | ❷ Control box | ❸ Operation panel | ❹ Foot switch |
| ❺ Motor | ❻ Tension release lever | ❼ Pulley | ❽ Spool stand |
| ❾ Button feeder | ❿ Vibrating bowl | ⓫ Control box | |
| Safety devices; | | | |
| ⓬ Eye guard | ⓭ Thread take-up cove | ⓮ Belt cover | ⓯ Motor cover |

2. SPECIFICATIONS







2-1. Specifications

Stitch formation	Single needle lock stitch
Maximum sewing speed	2,000 spm
Maximum pattern size	0-6.5×0-6.5 mm
Needle	TQ×1 #16
Dimensions of buttons that can be sewn	Outer diameter of button 9-22 mm Space between the button holes 2.5-6.5 mm
Button clamp lifter	10 mm max.
Thread knot	Knot tied by needle
Feed mechanism	R-θ intermittent feed mechanism (pulse-motor driven mechanism)
Stitch length	0.1-6.5 mm
Number of stitches	Any of 12, 14, 16, 18, 19, 21, 22, 23, 24, 25, 26, 27, 32
Maximum stitch number	5,000 stitches (including 4,000 stitches which can be added)
Work clamp lifter	Solenoid type
Work clamp height	17 mm max.
Rotary hook	Shuttle hook
Wiper device	Standard equipment (Linked to presser lifter)
Thread trimmer device	Standard equipment
Data storage method	PROM (Any sewing pattern can be added using BAS-PC/300.)
Number of stored data	22 sewing patterns are set already. (Up to 50 patterns can be added. Total number of stitches of stored data which can be added is within 4,000.)
Motor	Three-phase 400 W induction motor
Weights	Machine head: 47 kg BA- 16 : 37 Kg Control box: 9-19 kg (depending on destination)
Power supply	Single-phase 220 V, 230 V 50 Hz 3-phase 220 V 60 Hz, 380 V 50 Hz, 415 V 50 Hz Maximum electric power consumption; 600 VA





2-2. Program list

- There are 22 standard sewing patterns.

(Any program is available as long as the needle drops down into the hole of the button.)

Program No.	No. of button holes	Sewing pattern	No. of threads	No. of crossover stitches	No. of stitches	Standard sewing length X	Standard sewing width Y
01	2		6	—	12	3.5	0.0
02			8	—	14		
03			10	—	16		
04			12	—	18		
05 ※1			16	—	22		
06 ※1			20	—	26		
07 ※2	3		6	—	12	0.0	3.5
08 ※2			12	—	18		
09 ※2	3		5-5-5	—	21	2.7	2.34
10	4		6-6	1	19	3.5	3.5
11			8-8	1	23		
12			8-8	3	25		
13			10-10	1	27		
14 ※3			6-6	0	24		
15 ※3			10-10	0	32		
16			6-5	1	18		
17			8-7	1	22		

2. SPECIFICATIONS

Program No.	No. of button holes	Sewing pattern	No. of threads	No. of crossover stitches	No. of stitches	Standard sewing length X	Standard sewing width Y	
18	4		6-6	1	19	3.5	3.5	
19			8-8	1	23			
20 ^{※3}			6-6	0	24			
21 ^{※2}				6-6	1	19		2.5
22 ^{※2} ^{※3}					6-6	0		

- *1) Check that the button hole diameter is 2 mm or greater before using program Nos. 5 or 6.
 - *2) Remove the button lifter spring before using program Nos. 7, 8, 9, 21 or 22.
 - *3) For program Nos. 14, 15, 20 and 22, after the sewing of one side is completed, the presser foot lifts up once and the wiper operates, and then the other side is sewn, because there is no crossover thread to be sewn. (Operation will be different if the optional solenoid-type thread wiper is installed. [Refer to page 5].)
- If you want to sew a pattern other than one of the standard 24 patterns, you can create your original pattern using the BAS-PC/300.
Consult with your local Brother Sales Office for details.

2-3. Optional parts

- Handy switch

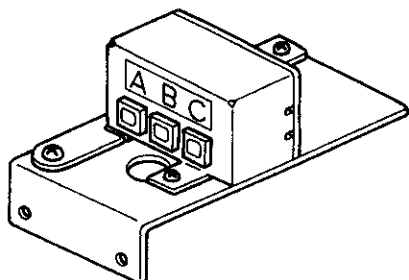

This switch enables the operator easy access to 6 different types of sewing data registered in the user program (see page 45). Sewing data can be switched easily even with workpiece clamped.

Make sure that the needle drops down into the hole of the button. (Refer to "6. CHECKING THE SEWING PATTERN".)

- Two-pedal foot switch

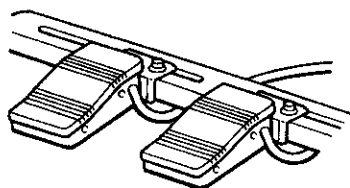

The switch has an independent presser switch (left side) and start switch (right side).

- Solenoid-type thread wiper

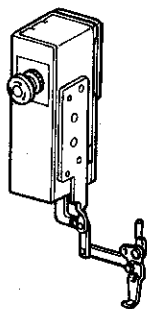

When sewing without crossover threads (program Nos 14, 15, 20 and 22), do not move the button clamp assembly vertically while sewing is in progress. (Refer to "Changing special functions using the memory switches" on page 48.)

- Button spacer set
S09661-001





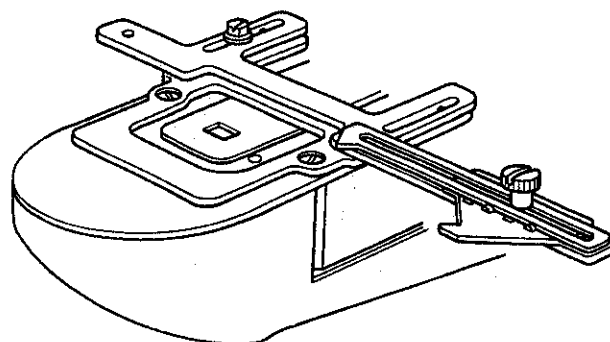
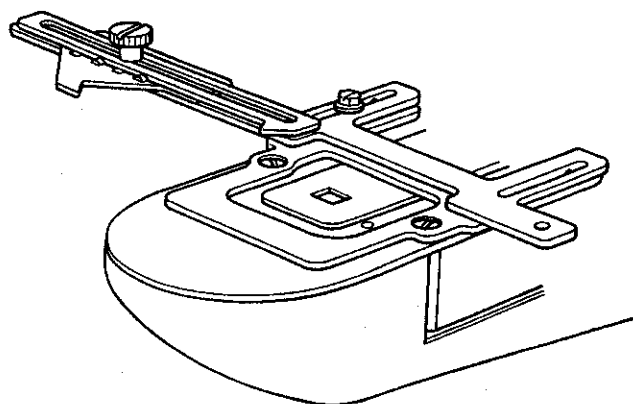



For men's garments

For women's garments



3. INSTALLATION

CAUTION

-  Machine installation should only be carried out by a qualified technician.
-  Contact your Brother dealer or a qualified electrician for any electrical work that may need to be done.
-  The sewing machine head weighs more than 47 kg. The installation should be carried out by two or more people.
-  Do not connect the power cord until installation is complete, otherwise the machine may operate if the foot switch is depressed by mistake, which could result in injury.
-  Hold the machine head with both hands when tilting it back or returning it to its original position. Furthermore, after tilting back the machine head, do not push the face plate side or the pulley side from above, as this could cause the machine head to topple over, which may result in personal injury or damage to the machine.
-  All cords should be secured at least 25 mm away from any moving parts. Furthermore, do not excessively bend the cable or secure it too firmly staples, otherwise there is the danger that fire or electric shocks could occur.
-  Be sure to connect the ground. If the ground connection is not secure, you run the risk of receiving a serious electric shock.
-  Install the belt covers to the machine head and motor.
-  Avoid setting up the sewing machine near sources of strong electrical noise such as high-frequency welding equipment. If this precaution is not taken, incorrect machine operation may result.

3-1. Power table

- Use the power table which has been specially designed for the B448E.

* If using a commercially-available table, process it as shown in the illustration below.

	Model code
Table/legs assembly	127-Z48-00001

NOTE: The thickness of the table should be at least 40 mm, and it should be strong enough to bear the weight and vibration of the sewing machine.

If the distance A between the insides of the legs is less than 740 mm, move the control box installation position closer to the motor (B=247 mm).

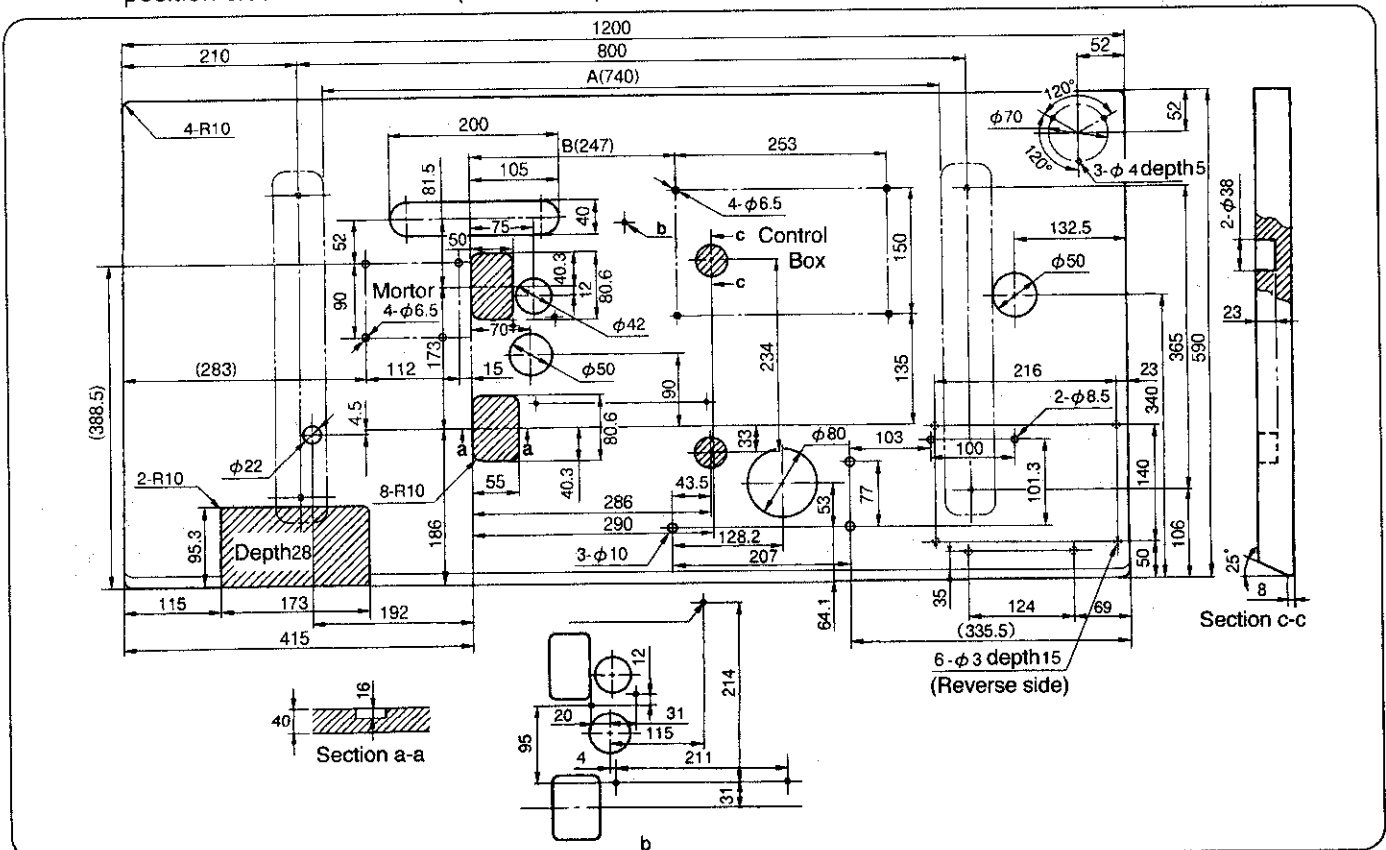

3-2. Installing the motor

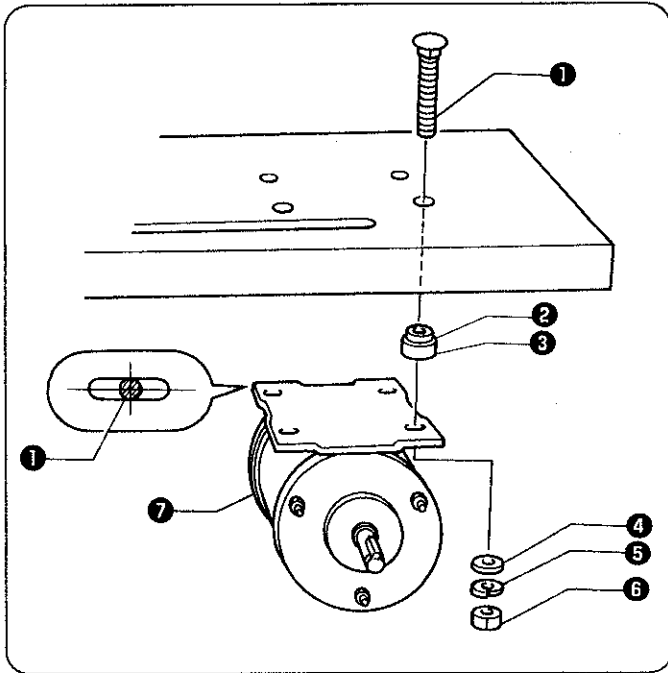

Install the motor **7** to the work table with the four accessory bolts **1**, cushions **2**, cushion collars **3**, flat washers **4**, spring washers **5** and nuts **6**.

* At this time, secure so that the bolt **1** is close to the center of the oval hole in the motor.

3-3. Installing the motor pulley

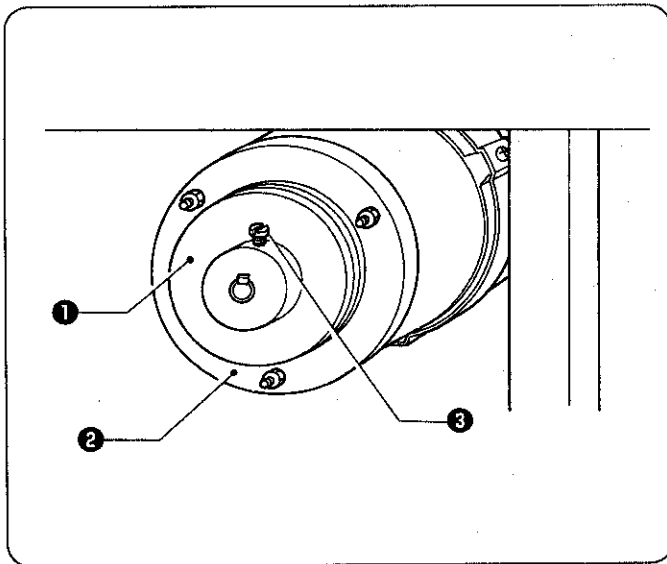

Place the motor pulley **1** onto the shaft of the motor **2** so that the key groove is aligned, and then tighten the set screw **3** so that the center of the V groove in the motor pulley **1** is aligned as closely as possible with the center of the belt hole in the power table.

3. INSTALLATION

3-4. Installing the control box

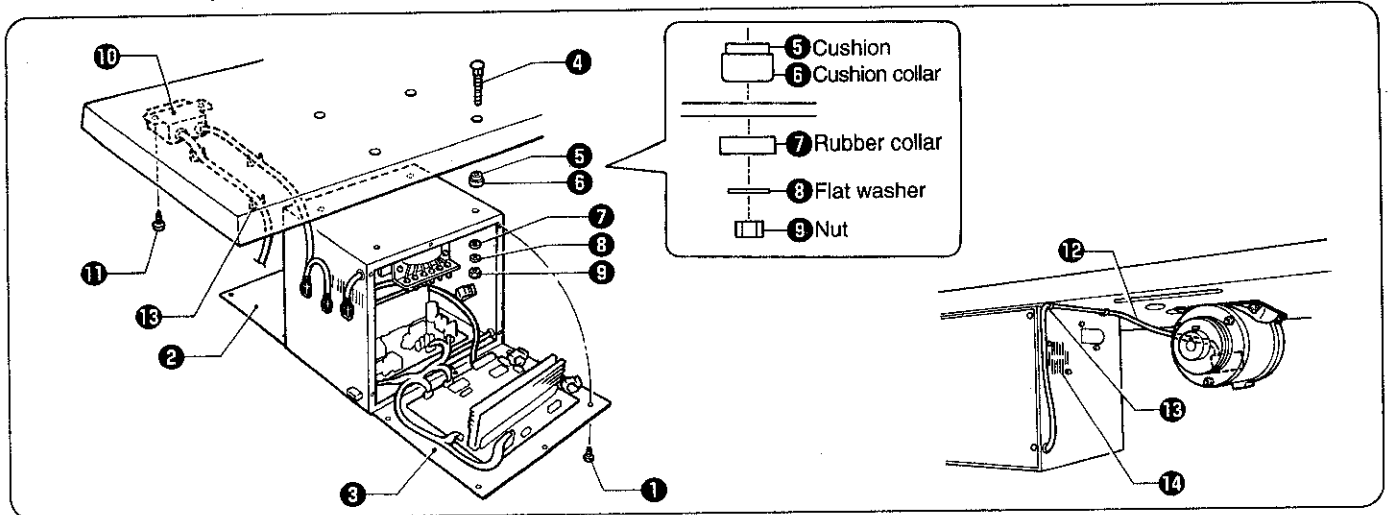

1. Remove the 12 screws **1**, and then open the covers (panel mounting assembly **2** and main P.C. board mounting plate **3**).
Caution: When opening the cover, hold it securely so that it does not fall down.
 2. Install the control box with the four accessory bolts **4**, cushions **5**, cushion collars **6**, rubber collars **7**, flat washers **8** and nuts **9** as shown in the illustration above.
* At this time, leave a gap of approximately 1 mm between the work table and the top of the box.
 3. Close the covers (panel mounting assembly **2** and main P.C. board mounting plate **3**), and tighten them with the screws **1**.
* The main P.C. board mounting plate **3** will be opened again during "3-13. Connecting the cords", so provisionally tighten it with the screw **1**.
 4. Install the power switch **10** with the two screws **11**.
 5. Pass the cord **12** through the hole in the top of the terminal board.
 6. Secure the power switch cord and the motor cord with the five staples **13**.
- NOTE 1: Secure the motor cord with staples in such a way that it does not cross over the outlet port of the cooling fan **14**.
- NOTE 2: Some specifications are not supplied with an accessory power switch **10**. For these specifications, connect a power switch which satisfies the necessary regulations in the country of use.

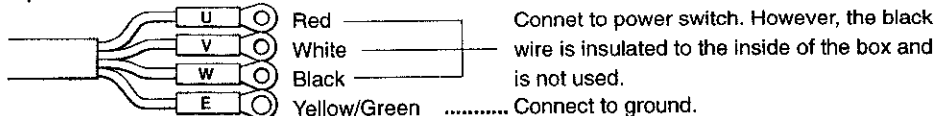

How to pass the cord

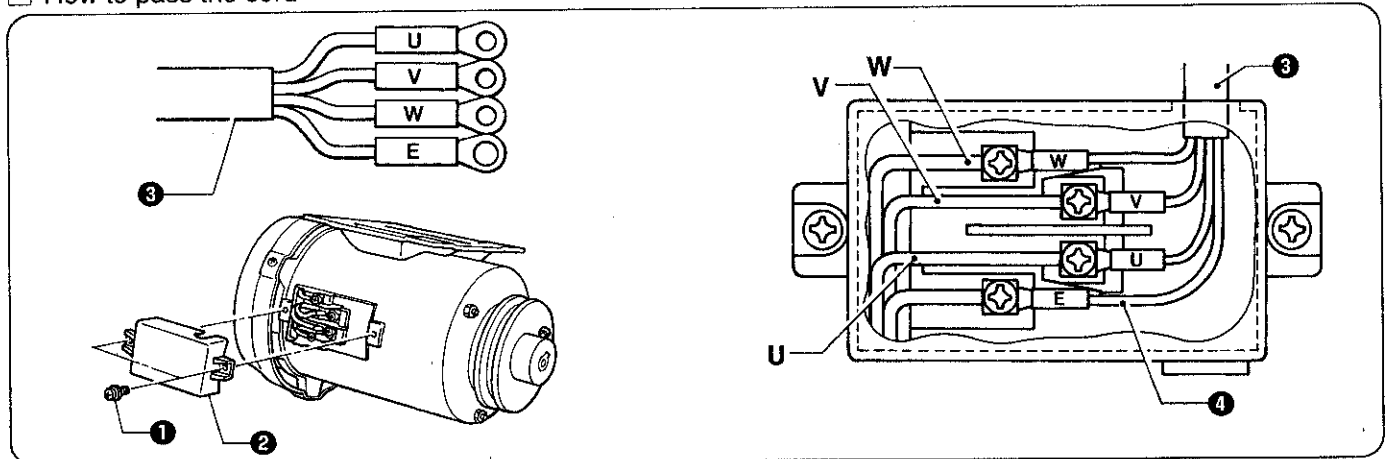

1. Loosen the screw **1**, and then open the terminal board cover **2**.
2. Pass the motor cord **3** through the hole in the top of the terminal board, align the U, V and W marks on the cord with the terminals marked U, V and W, and then secure the cords with the screws.
3. Secure the ground wire **4** of the motor cord **3** in the position shown in the illustration.
4. Install the terminal board cover **2** with the screw **1**.

3-5. Installing the rubber cushions

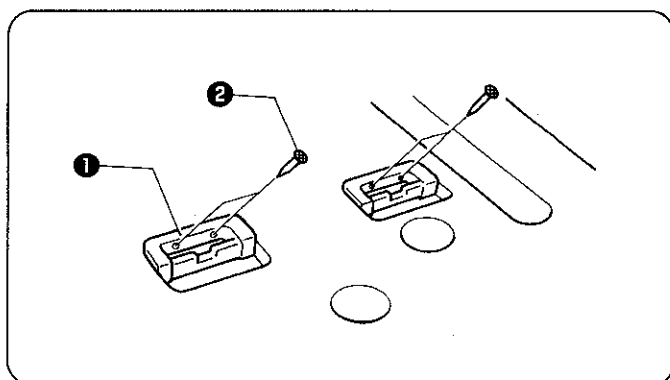

Install the rubber cushions **1** with the nails **2**.

3-6. Installing the oil pan

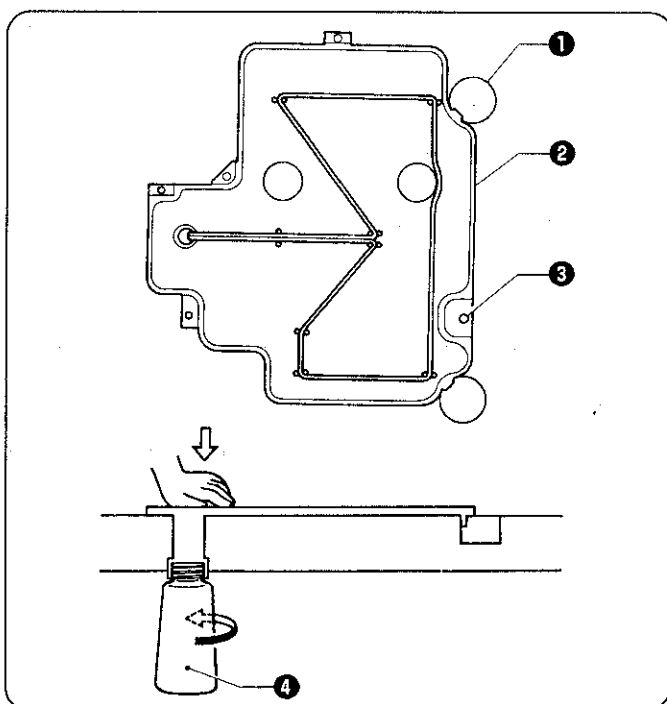

1. Insert the tabs of the oil pan **2** into the holes for the cushions **1**, and then secure it in place with the five nails **3** so that the oil pan **2** is not at an angle.
2. While pushing the oil pan **2** down from above, screw in the oil container **4**.

3-7. Installing the cushions

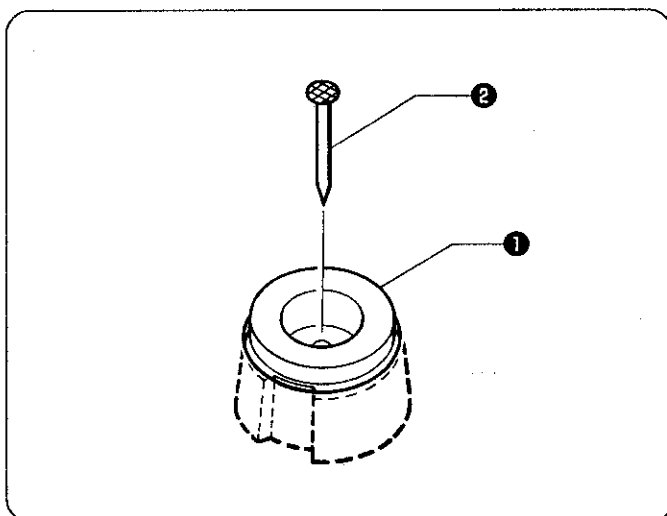

Place the two cushions **1** into the holes in the work table, and secure them in place with the nails **2**.

3.INSTALLATION

3-8. Installing the machine head

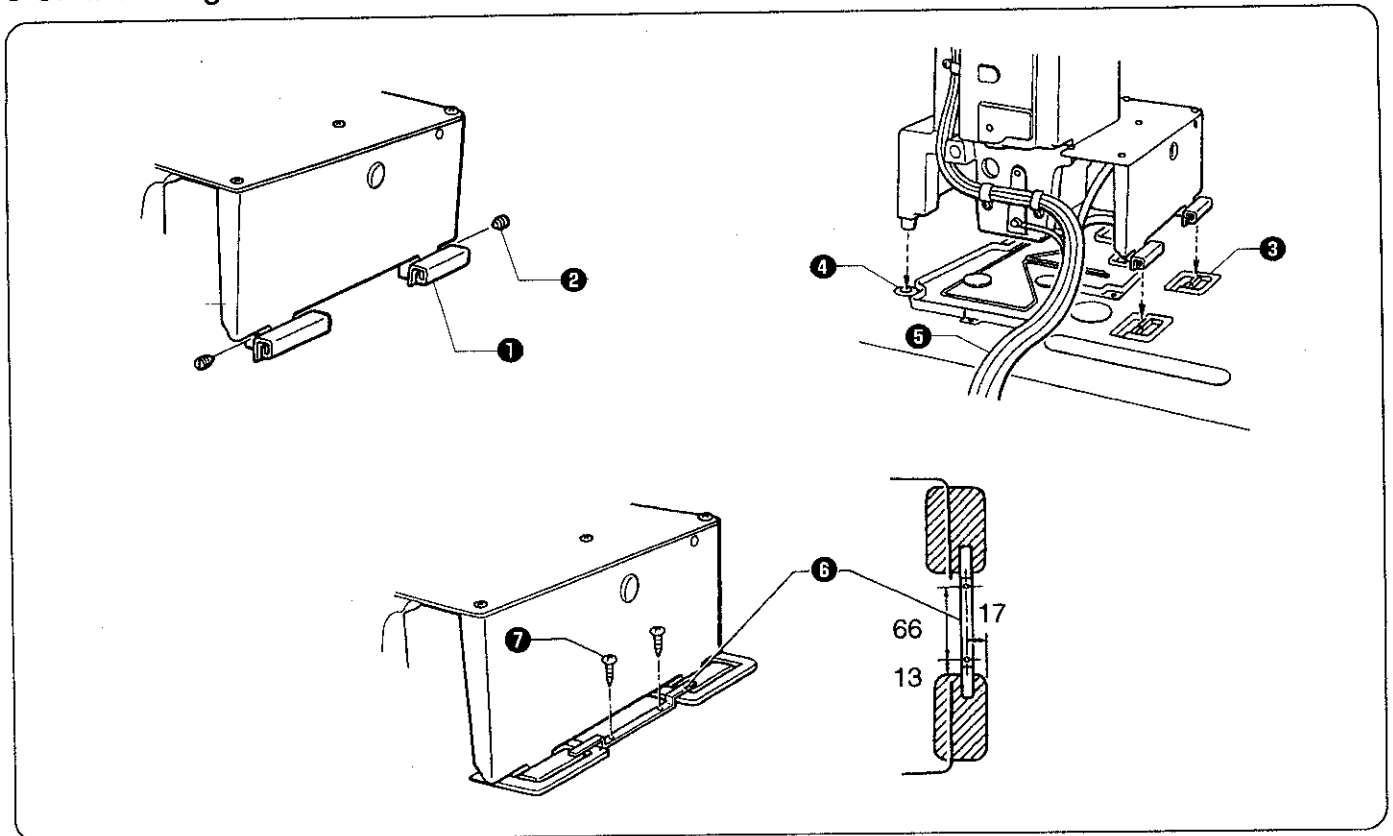

1. Insert the head hinges **1** into the machine head so that they are parallel, and then secure them with the two set screws **2**.
2. Place the machine head gently on top of the rubber cushions **3** and cushions **4**.
NOTE: Pull the cords **5** out as shown in the illustration above in order to prevent them from being clamped by the machine head.
3. Install the hinge presser **6** with the two screws **7**.

3-9. Installing the head rest

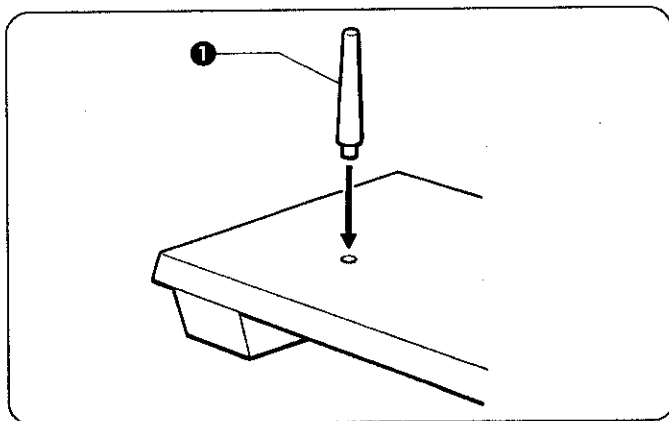

- Tap the head rest **1** into the table hole.
NOTE: Tap the head rest securely into the table hole.

3-10. Installing the vibrating bowl

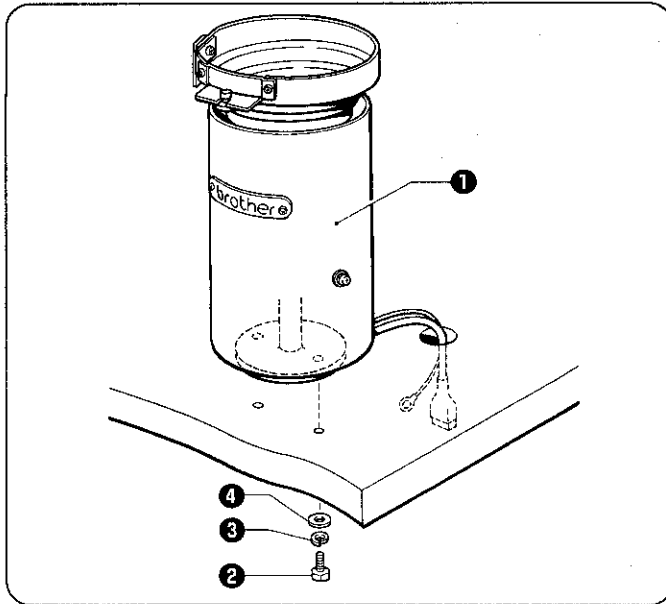

1. Install the vibration bowl ① with bolts ②, spring washers ③, and washers ④.
2. Pass the wires from the vibration bowl ① through the hole in the table.

3-11. Installing the control box (for vibrating bowl)

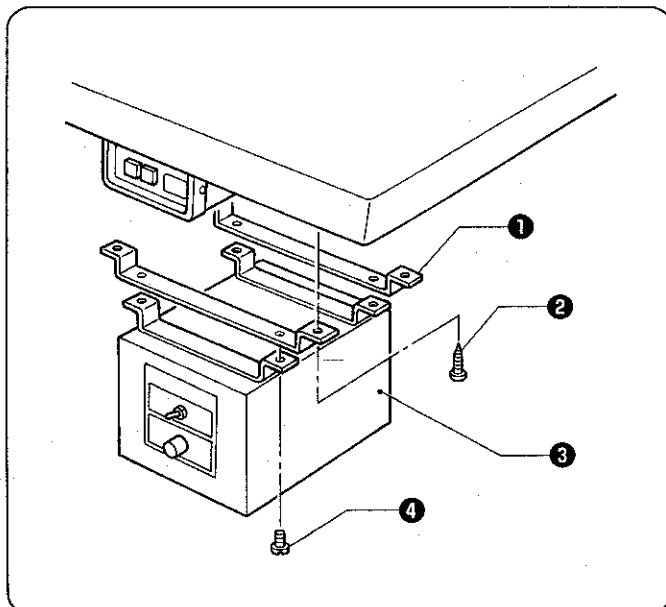

1. Mount the control box ③ to the bottom of the box stay with screws ④.
2. Mount the control box stay ① to the bottom of the work table with wood screws ②.

3-12. Installing the button feeder

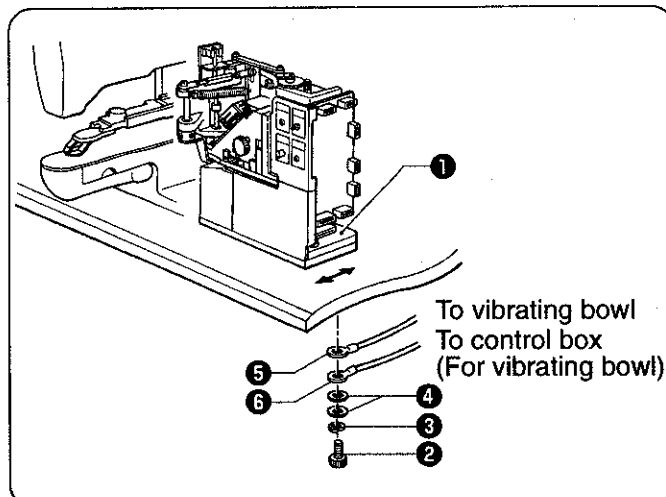

1. Move button feeder base ① to the front and rear and left and right as necessary to install it by using hole bolts ②, spring washers ③ and washers ④.
(And install ground wires ⑤⑥.)

3-13.Connecting the cords

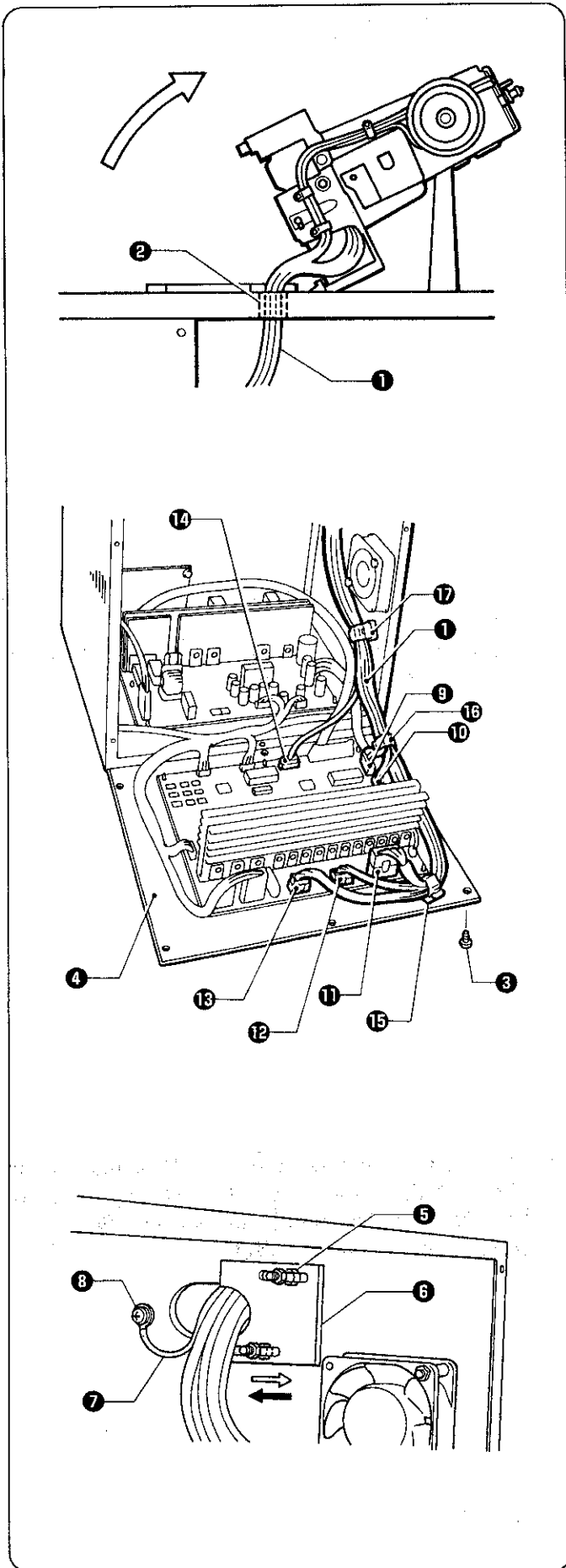

1. Gently tilt back the machine head.
Caution:After tilting back the machine head, do not push the face side or the pulley side from above.
 2. Pass the cords ① through the hole ② in the work table.
 3. Gently return the machine head to its original position.
 4. Remove the screws ③, and then open the control box cover (main P.C. board mounting plate ④).
Caution:When opening the cover, hold it securely so that it does not fall down.
 5. Loosen the two screws ⑤, and then open the cord presser plate ⑥ in the direction of the white arrow and pass the cords ① through the opening.
 6. Loosen the screw ⑧, and then connect the ground wire ⑦ that is coming from the machine head as shown in the illustration at left.
 7. Securely insert each of the connectors as indicated below.
(Connection indications)
*This is indicated on the P.C. board.
- | | |
|--|---------------|
| Connector ⑨ for sensor
(9-pin with ① mark)..... | P1 ORG |
| Connector ⑩ for synchronizer
(5-pin with ② mark)..... | P2 SYNCHRO |
| Connector ⑪ for solenoid
(4-pin with ⑤ mark)..... | P5 SOL |
| Connector ⑫ for pulse motor Y
(4-pin (blue) with ⑥ mark)..... | P6 YPM (blue) |
| Connector ⑬ for pulse motor X
(4-pin with ⑦ mark)..... | P7 XPM |
| Connector ⑭ for option
(5-pin with ⑬ mark)..... | P13 OPTION |
8. Secure the cords ① with the cord clamps ⑮⑯⑰.
 9. Close the cord presser plate ⑥ in the direction of the black arrow, and secure it by tightening the screws ⑤.
NOTE:Check that the cords do not get pulled when the machine head is tilted back gently.
 10. Tighten the cover (main P.C. board mounting plate ④) with the six screws ③.

Button feeder connection

★ Pull on the connector to make sure it will not come disconnected after connecting the pins.

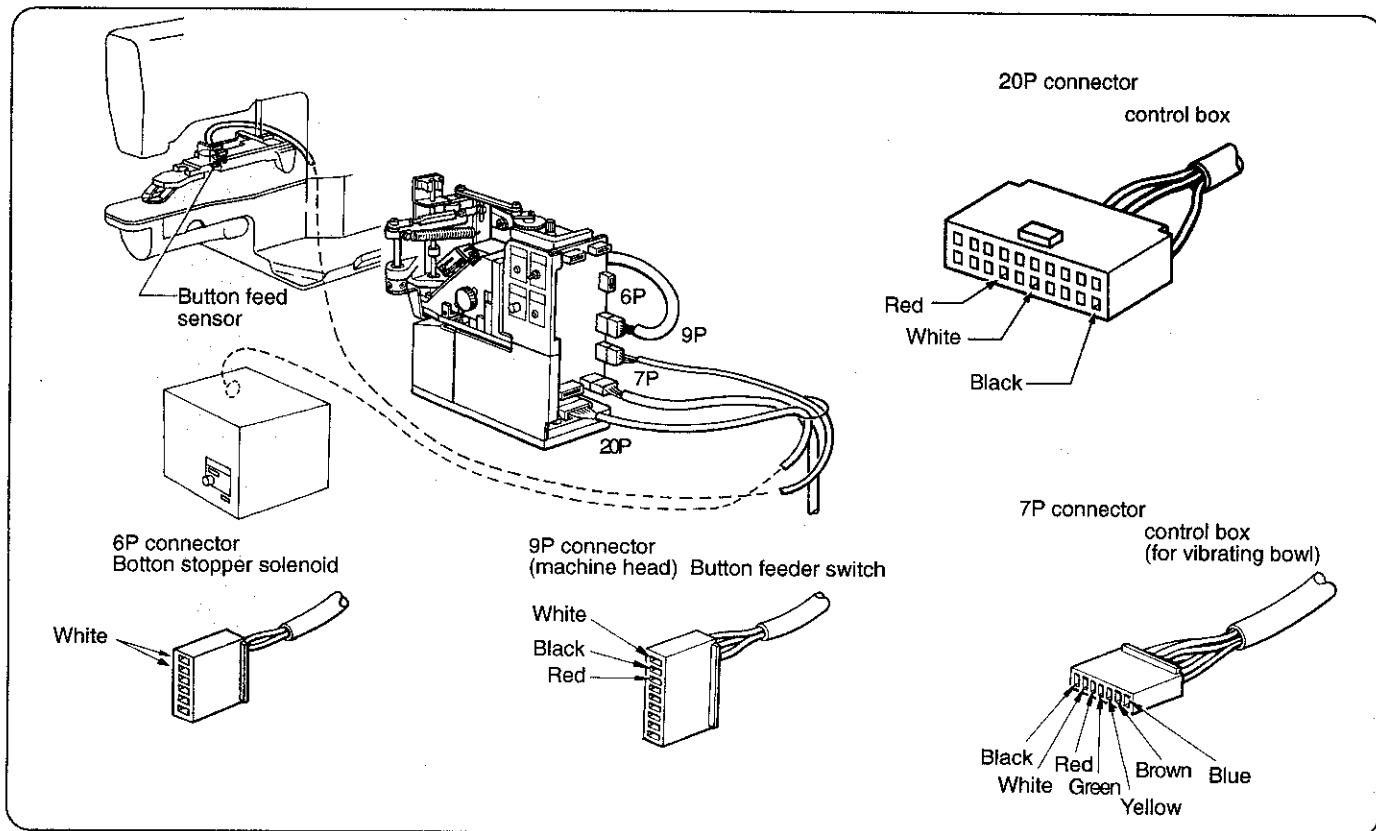

Control box (for vibrating bowl) connection

★ Connect the ground wire from the vibrating bowl to the motor.

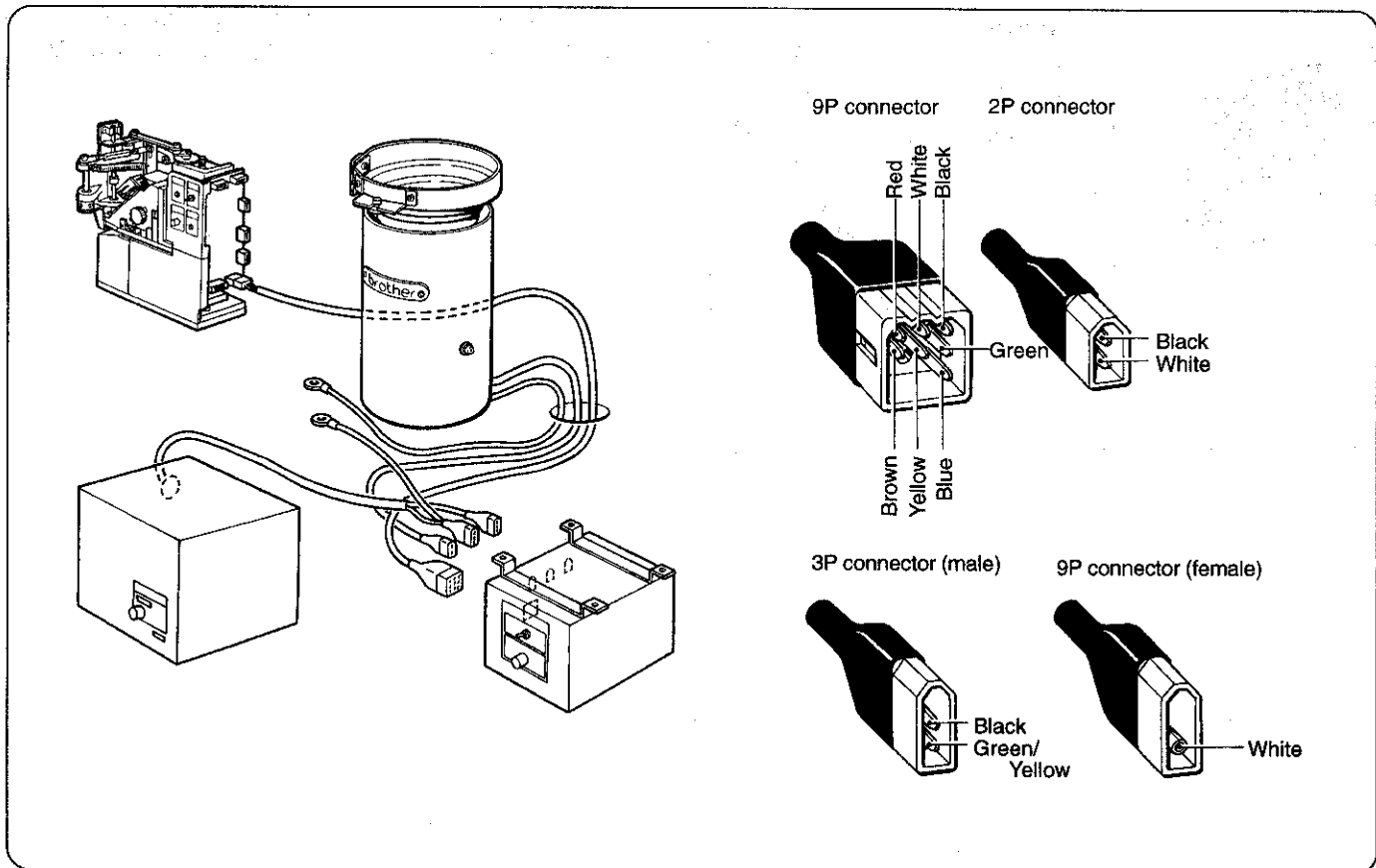

3.INSTALLATION

Power switch connection

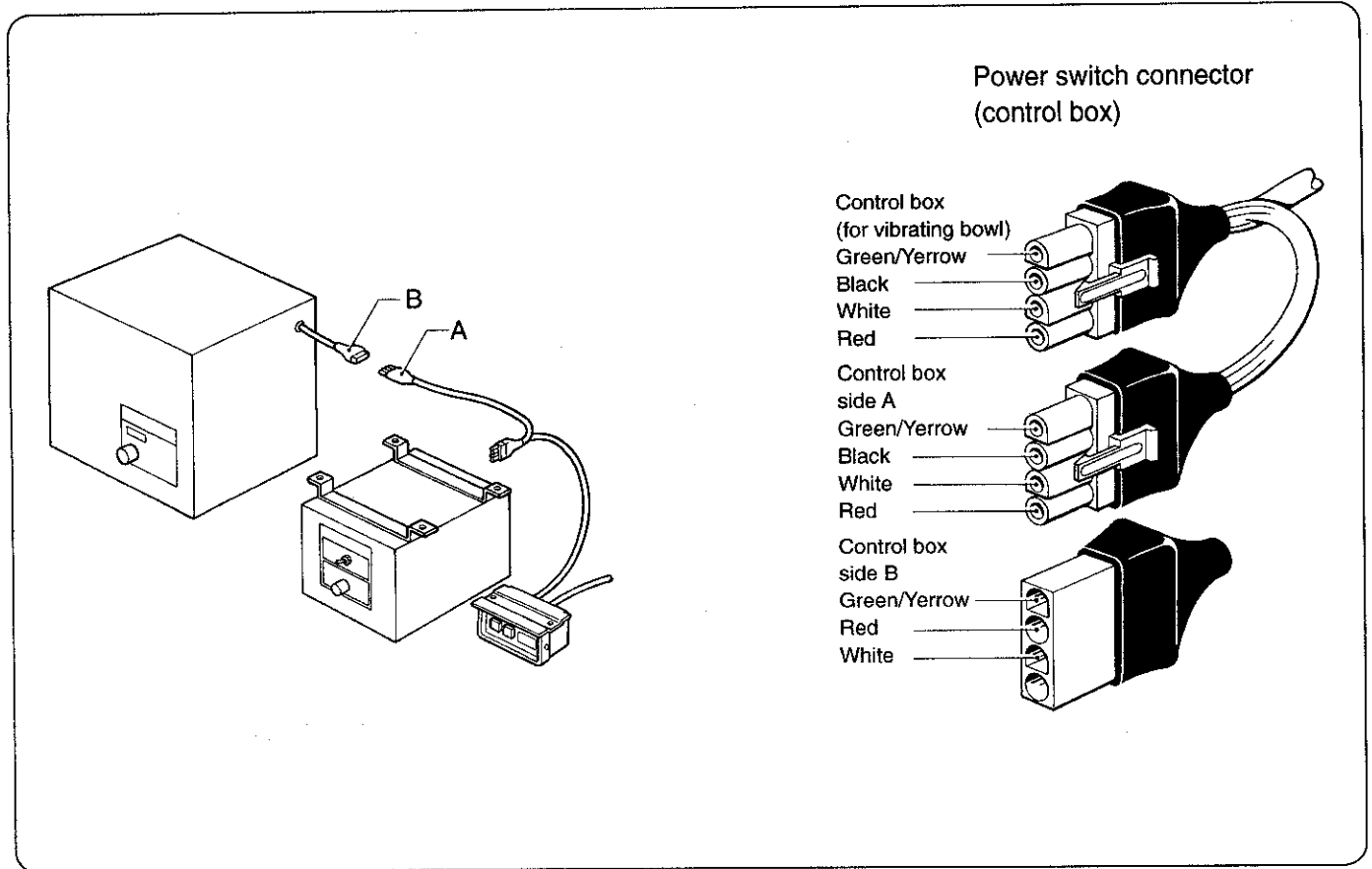

3-14. Installing the button feeder cover

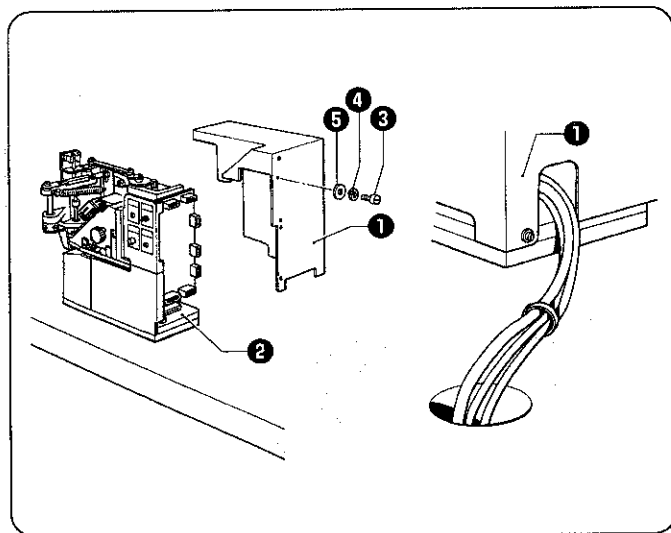

★ Attach the button feeder cover ① to the button feeder ② with screws ③, spring washers ④, and washers ⑤.

* Be sure to pass the wires through the hole in the cover when attaching the button feeder cover ①.

3-15.Installing the V-belt

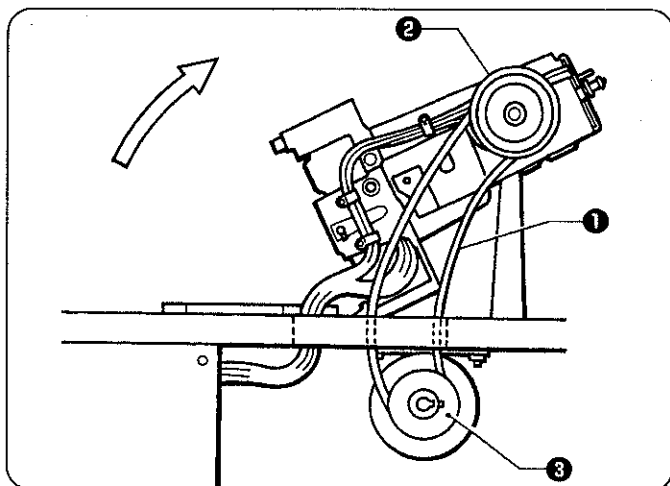

1. Gently tilt back the machine head, and then place the V-belt **1** into the V grooves on the machine head pulley **2** and the motor pulley **3**.

Caution: After tilting back the machine head, do not push the face plate side or the pulley side from above.

2. Gently return the machine head to its original position.
* Be careful not to clamp the cords at this time.

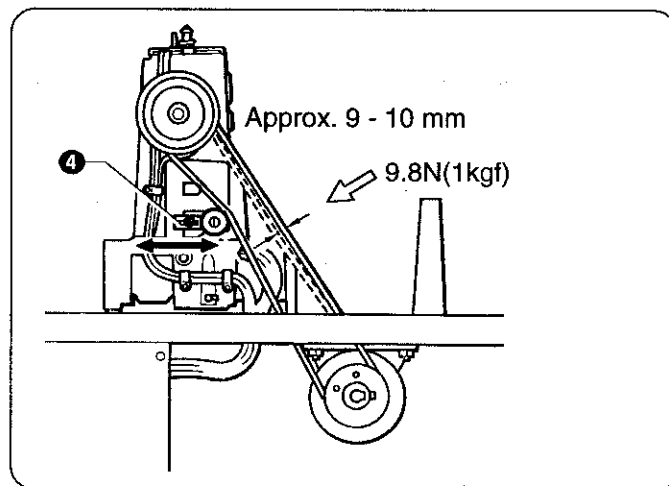

3. Install the accessory tension pulley assembly **4** to the machine head with the accessory flat washer, spring washer and bolt.
4. Adjust the belt tension by moving the tension pulley assembly to the right and left so that there is 9-10 mm of deflection in the V-belt **1** when it is gently pushed in the middle with a force of approximately 9.8 N (1 kgf).

* This tension is slightly stronger than BAS-300 series.

NOTE: Use brother specified V-belt (belt, VM).

The V-belt may stretch slightly when it is first used.

When above belt tension is weak, this will be cause of following problem;

- Noise and vibration become large.
- Needle up stop position becomes unstable.
- Error message [E-5] is displayed.

3-16. Installing the belt cover

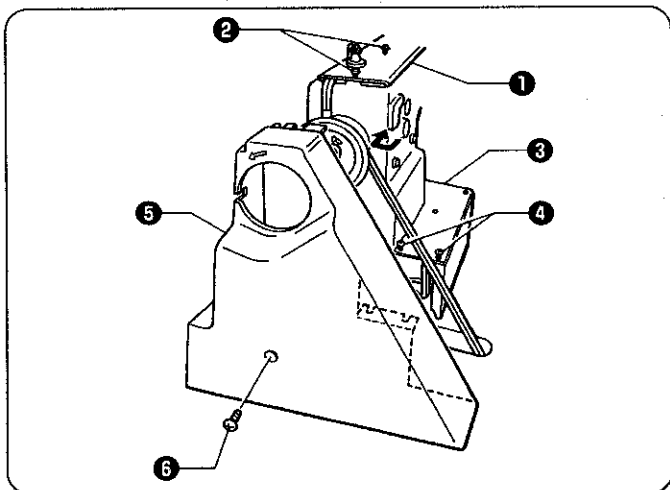

1. Loosen the two screws **2** of the upper cover **1** and the two screws **4** of bed cover L **3**.
2. Insert the belt cover **5** in the direction of the arrow, and then secure it with the two screws **2**, the two screws **4** and the screw **6**.

* When tilting back the machine head, loosen the screws **2** and **4**, remove the screw **6** and then remove the belt cover **5** first.

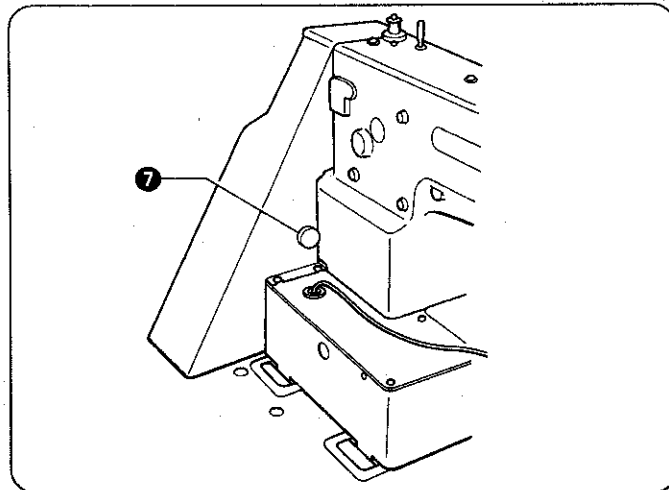

3. Attach the rubber plug **7** to the belt cover.

3. INSTALLATION

3-17. Installing the foot switch

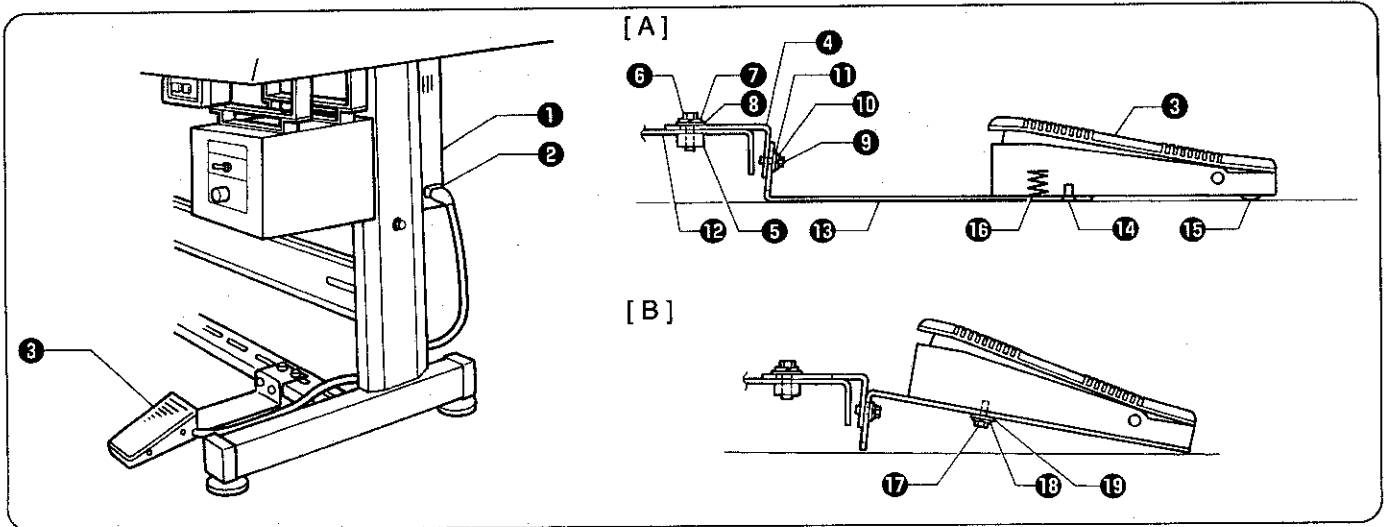

1. Insert the connector of the foot switch ③ into the connector ② of the control box ①.
 2. Install the foot switch ③ to the work table leg ⑫ with foot switch support plate A ④, foot switch support plate C ⑤, the bolt ⑥, spring washer ⑦, flat washer ⑧, bolt ⑨, spring washer ⑩ and flat washer ⑪ as shown in Figure A.
- ★ If foot switch support plate B ⑬ is used in a back-to-front position, it can be used as shown in Figure B.

1. Remove the screw ⑭ and rubber plug ⑮.
* Note that the spring ⑯ will come out when the screw ⑭ is removed.
2. Turn foot switch support plate B ⑬ back to front, and then install it with the bolt ⑰, spring washer ⑱ and flat washer ⑲ as shown in Figure B.

NOTE: If using the optional two-pedal foot switch, change the setting of DIP switch A on the operation panel while referring to "Setting the presser mode" on page 43.

3-18. Installing the motor cover

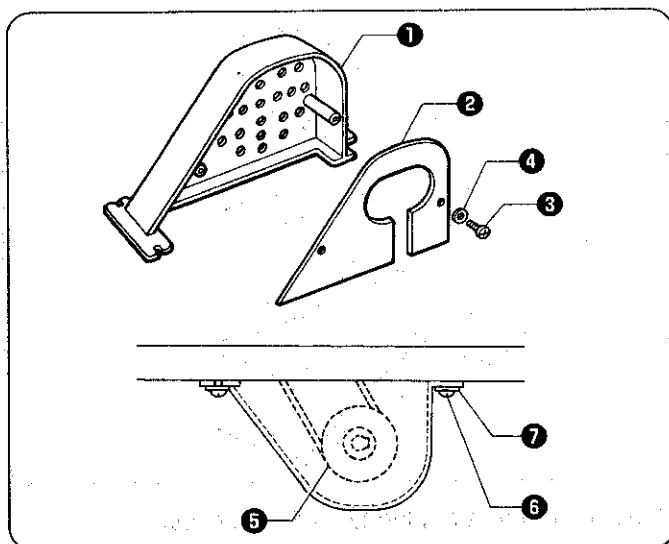

1. Install the motor cover ① to the motor back cover ② with the screws ③ and the flat washers ④.
2. Pass the motor shaft through the notch in the motor back cover ②, and then tighten the screws ⑤ and the washers ⑦ so that the clearance between the motor pulley ⑤ and the motor cover ① is uniform.

3-19. Installing the spool stand

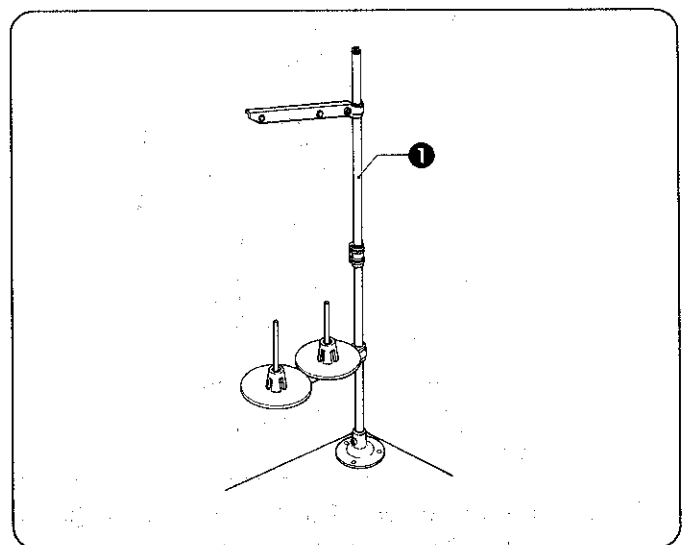

- Assemble the spool stand ① while referring to the spool stand instruction manual, and then install the spool stand ① at the right side of the work table.

3-20. Installing the shooter

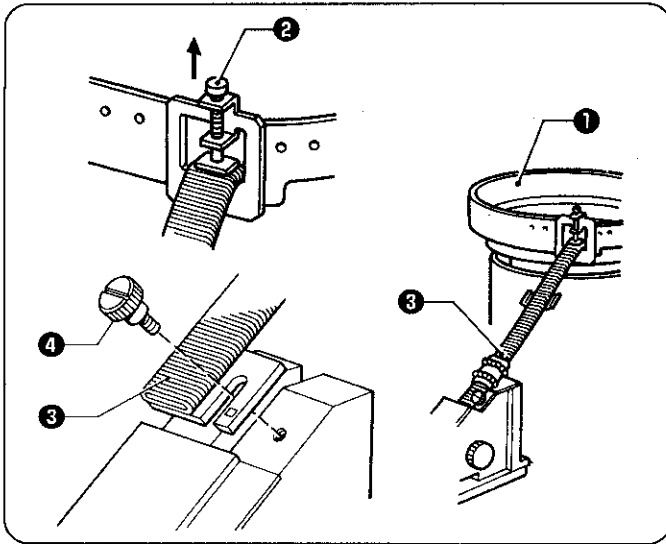

1. Raise the shooter lock pin **2** on the vibrating bowl **1**, and secure the shooter **3** by inserting the pin **2**, through the notch in the shooter.
2. Secure the shooter **3** with thumb screw **4** on button feeder **5**.

4. LUBRICATION

⚠ CAUTION

- ⚠ • Turn off the power switch before starting lubricating, otherwise the machine may operate if the foot switch is depressed by mistake, which could result in injury.
- ⊘ • Be sure to wear protective goggles and gloves when handling the lubricating oil and grease, so that they do not get into your eyes or onto your skin, otherwise inflammation can result. Furthermore, do not drink the oil or eat the grease under any circumstances, as they can cause vomiting and diarrhoea. Keep the oil out of the reach of children.

NOTE 1: Fill the machine with oil when the oil level is down to about one-third full in the oil sight glass. If oil is not added and the oil drops below this level, there is the danger that the machine may seize during operation.

NOTE 2: Be sure to let the machine operate for a while after adding the oil.

NOTE 3: Use only specified Brother oil (Nisseki sewing Lube 10) for the machine oil.

4-1. Lubrication points

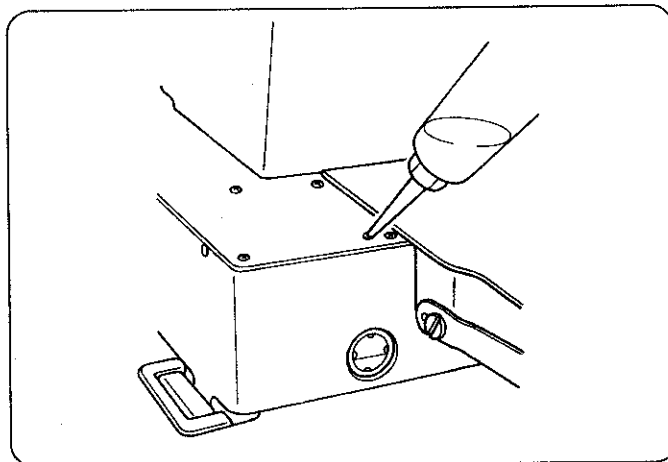
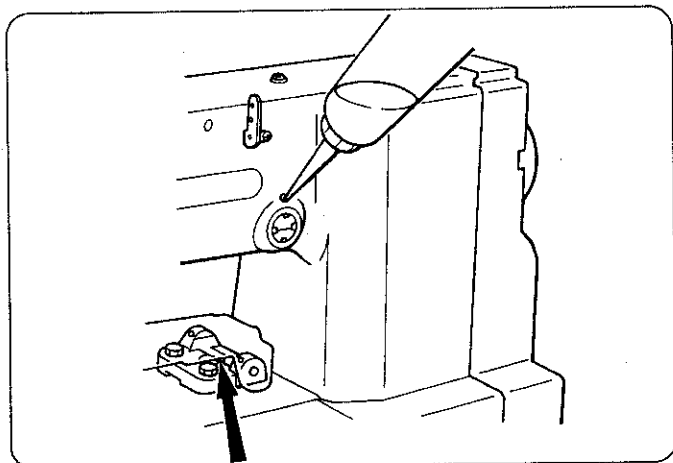

1. Fill the arm-side oil tank with oil.

* When setting up the sewing machine and when it hasn't been used for an extended period of time, be sure to add 2-3 drops of oil at the place indicated by the arrow.

2. Fill the bed-side oil tank with oil.

4-2. Applying grease

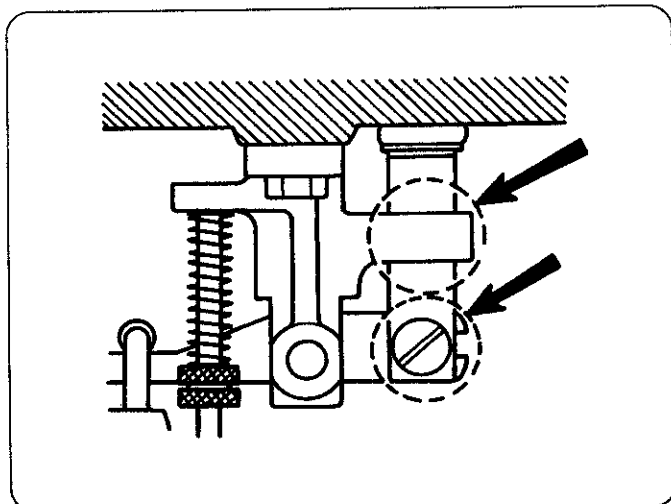

Do not apply too much grease in the place indicated by the arrow. If too much grease is applied here, the button clamp may not move up and down smoothly and error [E-6 □] may appear on the display.

5. OPERATION

5-1. Name and function of each operation panel item

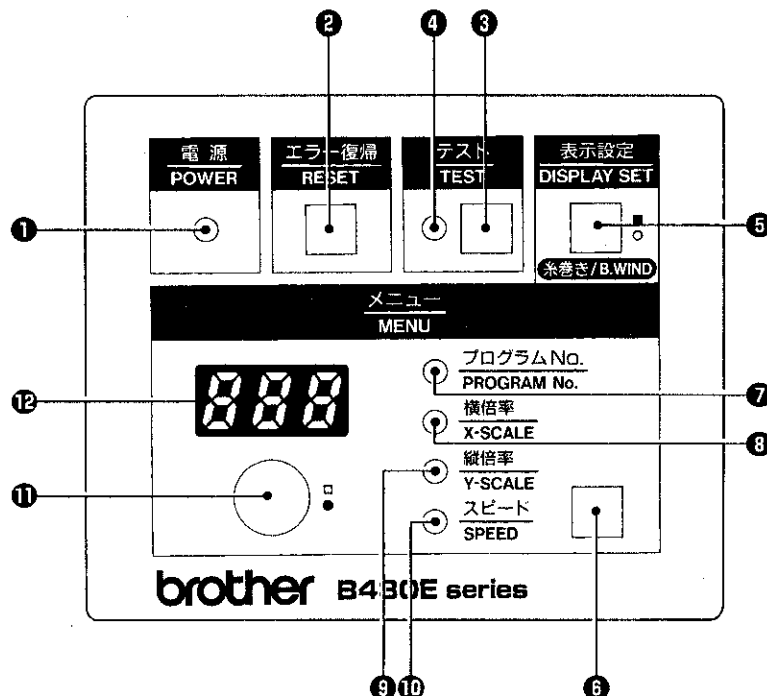

- 1** POWER indicator
Illuminates when the power switch has been turned on.
- 2** RESET switch
Press this switch to reset the machine when an error occurs.
- 3** TEST switch
Use this switch when you want to operate only the feed mechanism in order to check a pattern.
- 4** TEST indicator
Illuminates when the TEST switch has been pressed.
- 5** DISPLAY SET/B.WIND switch
Press this switch at the same time as you turn the rotary switch **11**. In addition, it is also used when winding the lower thread.
- 6** Menu switch
Use this switch to select a menu (program number, X and Y feed and speed). Each time the switch is pressed, one of the menu indicators (**7** to **10**) illuminates, and the setting for that menu item appears in the display **12**. The illuminated indicator changes as follows each time the switch is pressed.
PROGRAM No. indicator **7** → X-SCALE indicator **8** → Y-SCALE indicator **9** → SPEED indicator **10**
- 7** PROGRAM No. indicator
Illuminates when the menu switch **6** is pressed to Show the program number setting.
- 8** X-SCALE indicator
Illuminates when the menu switch **6** is pressed to Show the X-scale setting.
- 9** Y-SCALE indicator
Illuminates when the menu switch **6** is pressed to Show the Y-scale setting.
- 10** SPEED indicator
Illuminates when the menu switch **6** is pressed to Show the speed setting.
- 11** Rotary switch
You can change the menu setting which appears in the display **12** by turning this switch while pressing the DISPLAY SET/B.WIND switch **5**.
- 12** Display
This display will indicate the current status for the selected menu, error or memory switch.

5. OPERATION

5-2. Operating procedure

Preparation

Turn on the power switch.
(The POWER indicator ❶ will illuminate and the program number will flash in the display ❷.)

	Factory default	Variable range
Program No.	00*	01-22
X-scale	100 (%)	0-190 (%)
Y-scale	100 (%)	0-190 (%)
Speed	200 (2,000 spm)	100-200 (1,000-2,000 spm)

※ For checking the origin points for X and Y feed

Setting the program number..... Determine the appropriate program from the program list which is given on page 3.

- 1** Press the menu switch ❶ until the PROGRAM No. indicator illuminates.

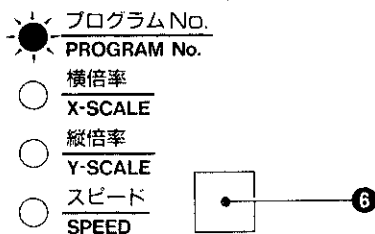

- 2** While pressing the DISPLAY SET/B.WIND switch ❷, turn the rotary switch ❸ until the desired program number is flashing in the display.

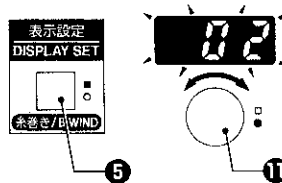

- 3** Depress the foot switch to the second step.
*The display will stop flashing and illuminate steadily, and the feed mechanism will move to the sewing start position.

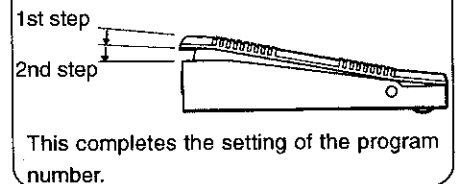

Setting the X-scale and Y-scale

- 1** Press the menu switch ❶ until the X-SCALE or Y-SCALE indicator illuminates.

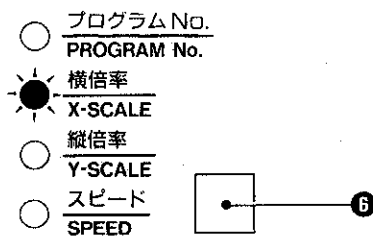

- 2** While pressing the DISPLAY SET/B.WIND switch ❷, turn the rotary switch ❸ until the desired scale setting is flashing in the display. (The setting is displayed as a percentage.)

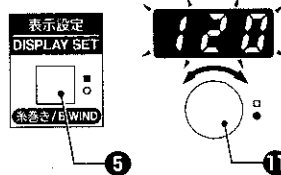

- 3** Depress the foot switch to the second step.
*The display will stop flashing and illuminate steadily, and the feed mechanism will move to the sewing start position.

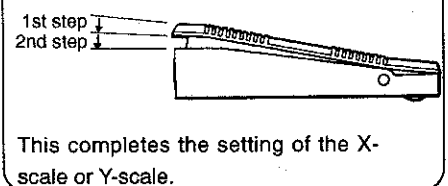

Setting the sewing speed

- 1** Press the menu switch ❶ until the SPEED indicator illuminates.

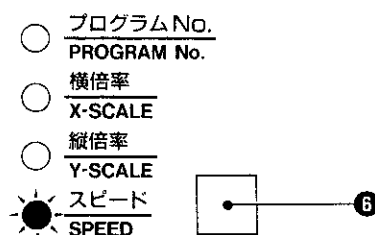

- 2** While pressing the DISPLAY SET/B.WIND switch ❷, turn the rotary switch ❸ until the desired speed setting is flashing in the display. (The setting is displayed in units of 10 spm.)

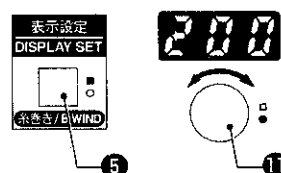

NOTE:

Be sure to check the sewing pattern (refer to page 21) after setting has been completed to make sure that the needle drops down into the hole of the button.

6. CHECKING THE SEWING PATTERN

<When checking by operating only the feed mechanism>

1. Turn on the power switch.
(The POWER indicator will illuminate and the program number will flash in the display.)

2. Depress the foot switch to the second step.
(The button clamp will rise.)

3. Install the button.
(Press the MANUAL switch.)

4. Press the TEST switch.
(The TEST indicator will illuminate.)



5. Depress the foot switch to the second step.
Only the feed mechanism will move.
(The feed mechanism advances by one stitch each time the foot switch is pressed.
After each stitch, turn the machine pulley by hand and check that the needle drops into the hole of the button.
*If you depress the foot switch again and keep it depressed after the feed mechanism has started to move, the feeding speed will increase.

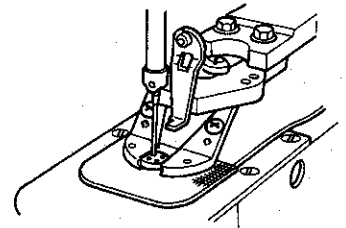

6. Press the TEST switch.
(The TEST indicator will switch off and the test mode will be cleared.)



7. Depress the foot switch.
The button clamp will rise and the preparation for sewing be completed.
* The button clamp will not rise unless the test feeding is carried out until the last stitch.

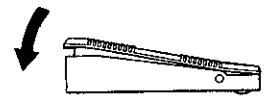

To ensure safety during use.....

- You can prevent accidental changes being made to programs by setting DIP switches 7 and 8 to ON.

When DIP switch 7 is ON

... The sewing pattern cannot be enlarged.

When DIP switch 8 is ON

... The program number cannot be changed.

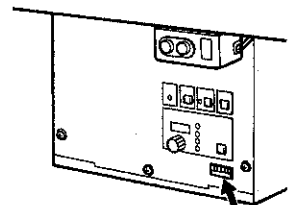

7. CORRECT USE

7-1. Selecting the needle and thread

Refer to the table for details on which needle and thread to select.

Needle	Thread	Type of thread
TQ×1 #16	#30-#60	Cotton or spun yarn

7-2. Installing the needle

CAUTION



- Turn off the power switch before installing the needle, otherwise the machine may operate if the foot switch is depressed by mistake and serious injury could result.

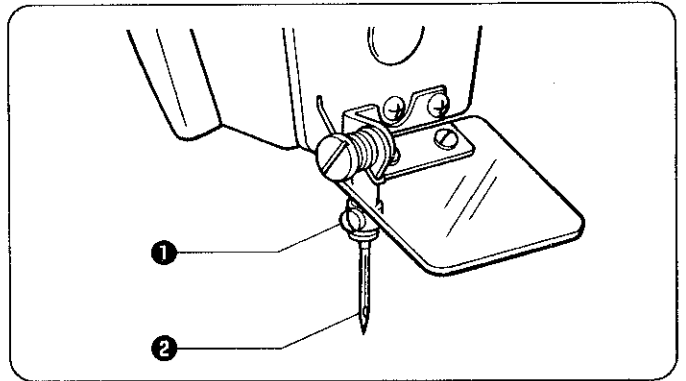

Loosen the set screw **1**, insert the needle **2** as far as it will go so that the groove is facing toward you, and then tighten the set screw **1**.

7-3. Threading the upper thread

CAUTION



- Turn off the power switch before threading the thread, otherwise the machine may operate if the foot switch is depressed by mistake and serious injury could result.

Thread the upper thread correctly as shown in the illustration below.

* If the tension release lever **1** is raised in the direction of the arrow, it will be easier to open the tension disc **2** and pull the thread through.

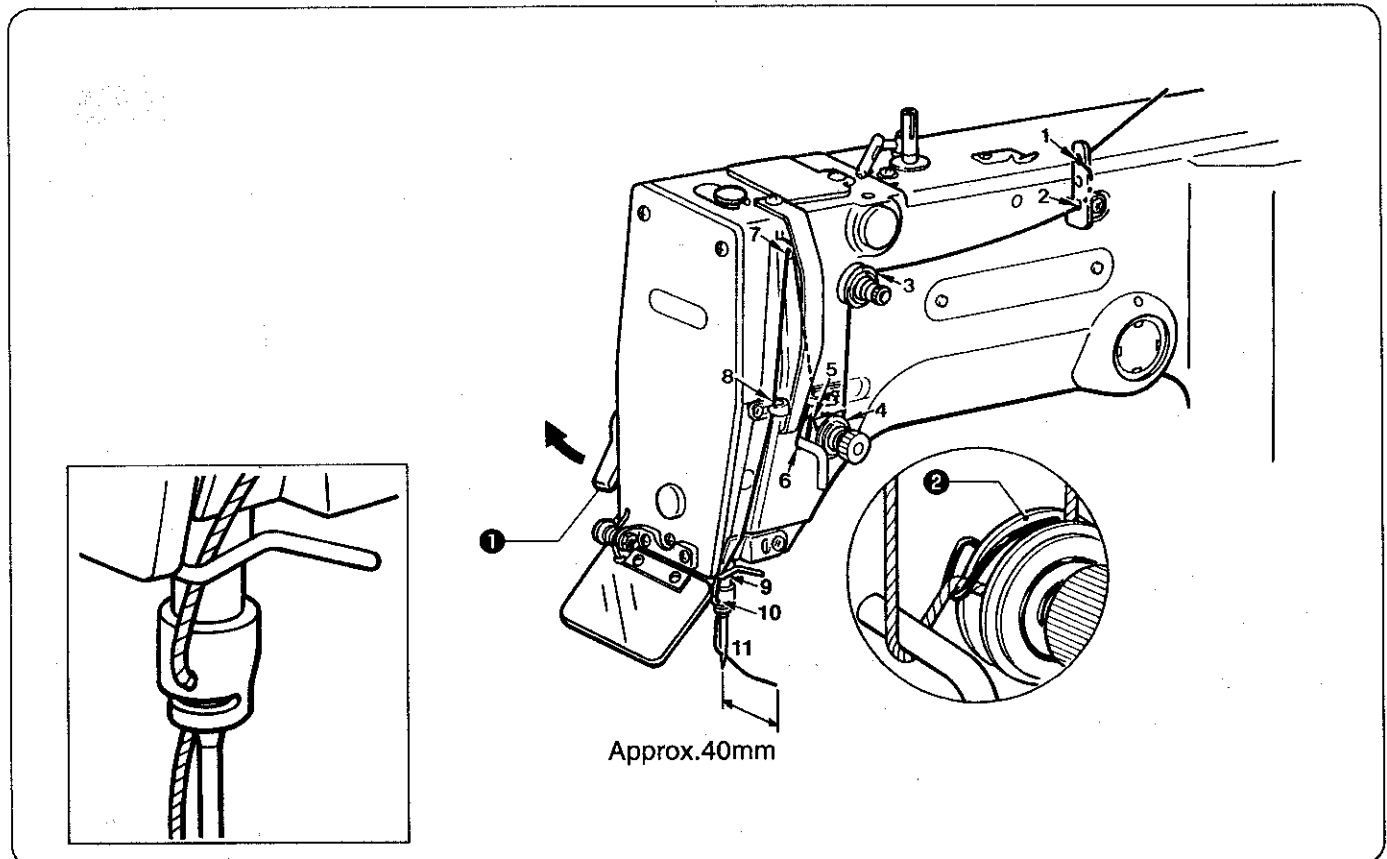

7-4. Winding the lower thread

 **CAUTION**

- Do not touch or place anything against any of the moving parts while winding the lower thread, otherwise personal injury or damage to the machine may result.

1. Place the bobbin all the way onto the shaft.



2. Thread the thread as shown in the illustration at right, wind the thread around the bobbin several times in the direction of the arrow, and then press the bobbin presser ①.



3. Turn on the power switch.
(The POWER indicator on the operation panel will illuminate.)



4. Turn off the FEEDER switch. (Return it after winding.)



5. Check that the button is not inserted and the needle does not touch the button clamp, and then while pressing the DISPLAY SET/B.WIND switch ② depress the foot switch ③ to start the machine. Keep depressing the foot switch ③ until the lower thread stops being wound onto the bobbin.
(Release the DISPLAY SET/B.WIND switch ② after the machine starts operating. If you release the foot switch before winding is completed, depress it once more while pressing and holding the DISPLAY SET/B.WIND switch ②.)

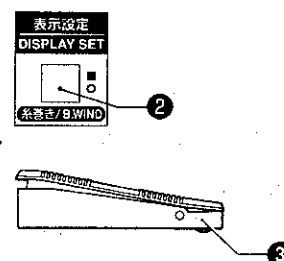

6. The bobbin presser ① will automatically return to its original position after a set amount of thread (80-90% of the bobbin capacity) has been wound on.



7. Release the foot switch ③.



8. Remove the bobbin, hook the thread onto the knife ④, and then pull the bobbin in the direction of the arrow to cut the thread.

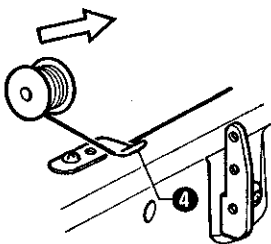

9. To wind more thread onto the bobbin, loosen the set screw ⑤ and pull the bobbin presser ① outward.

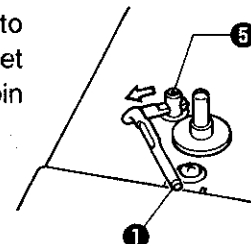

◀ If the thread winds onto the bobbin unevenly ▶

If the thread winds onto the bobbin unevenly, loosen the nut ① and turn the bobbin winder thread tension stud ② to adjust.

* If the thread winds on as shown in A, turn the bobbin winder thread tension stud ② clockwise; if it winds on as shown in B, turn the bobbin winder thread tension stud ② counterclockwise.

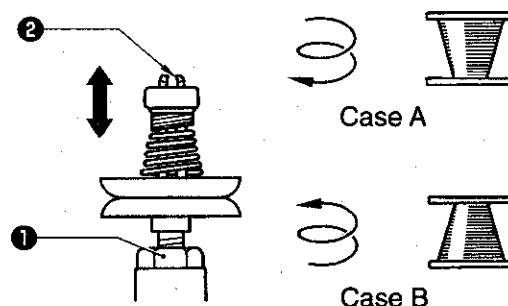

7-5. Replacing the bobbin case and threading the thread

⚠ CAUTION

- Turn off the power switch before removing and replacing the bobbin case, otherwise the machine may operate if the foot switch is depressed by mistake and serious injury could result.

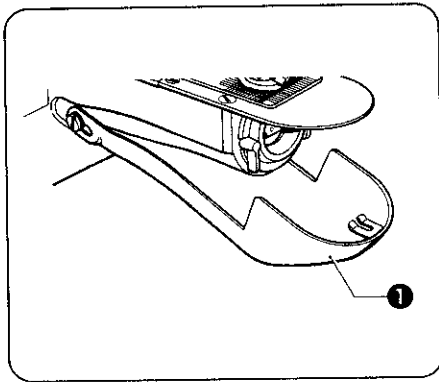

1. Pull the large shuttle hook cover **1** toward you to open it.

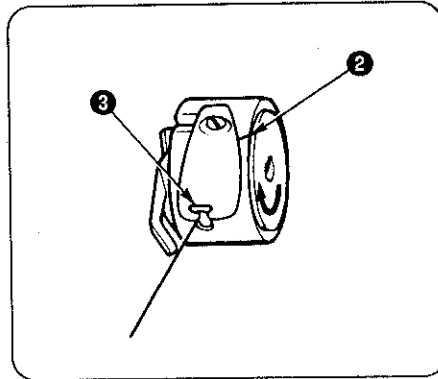

2. Insert a new bobbin into the bobbin case, and then pass the thread through the slot **2** and pull it out from the thread hole **3**.

Check that the bobbin turns in the direction of the arrow when the thread is pulled at this time.

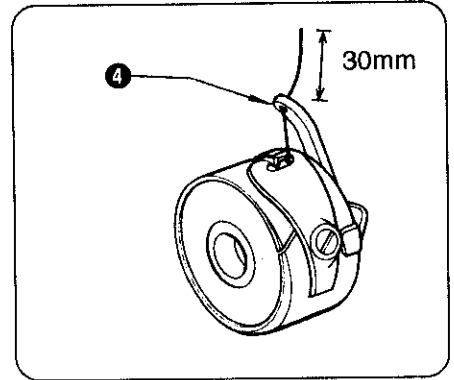

3. Pass the thread through the lever thread hole **4**, and then pull out approximately 30 mm of thread.

7-6. Thread tension reference guide

Upper thread tension	160~220g	Pre-tension	10~30g
Lower thread tension	40~50g	Normal sewing speed	2000spm
Thread takeup spring height	9~11mm	Thread trimming speed	400spm
Thread takeup spring tension	60~80g		

7-6-1. Lower thread tension

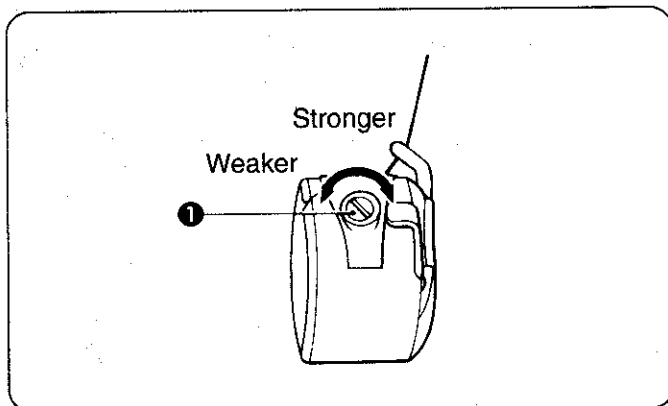

Adjust the thread tension to the weakest possible tension by turning the adjustment screw **1** until the bobbin case will not drop by its own weight while the thread end coming out of the bobbin case is held.

7-6-2. Upper thread tension

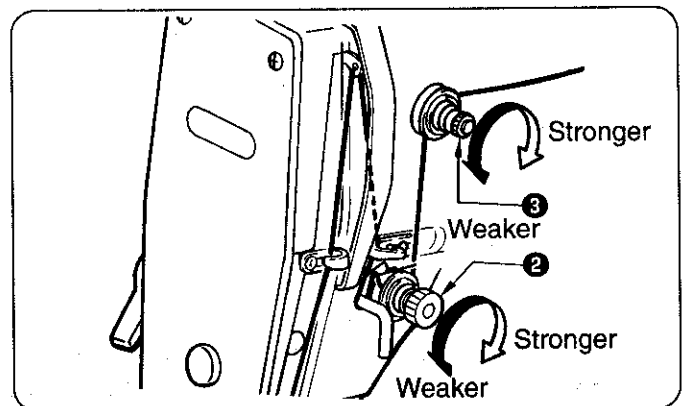

Turn the tension nut **2** (main tension) to adjust the tension as appropriate for the material being sewn. Furthermore, turn the thread nut **3** (sub-tension) to adjust the remaining length of upper thread to 35-40 mm.

7-6-3. Thread takeup spring height

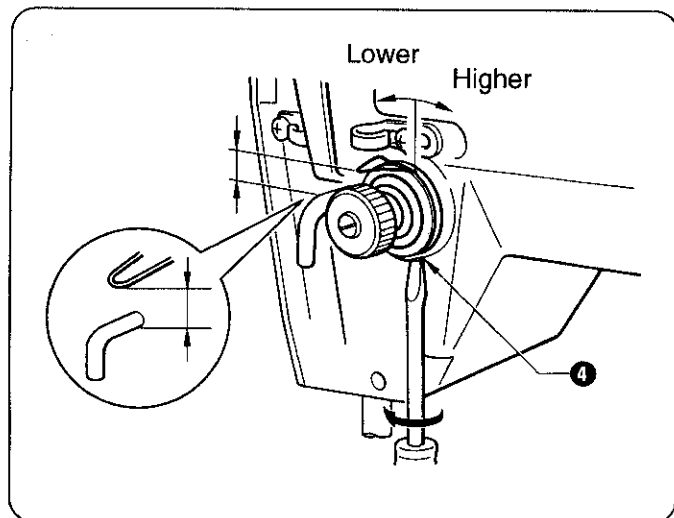

Loosen the set screw ④ and turn the tensioner body to adjust the thread takeup spring height.

7-6-4. Thread takeup spring tension

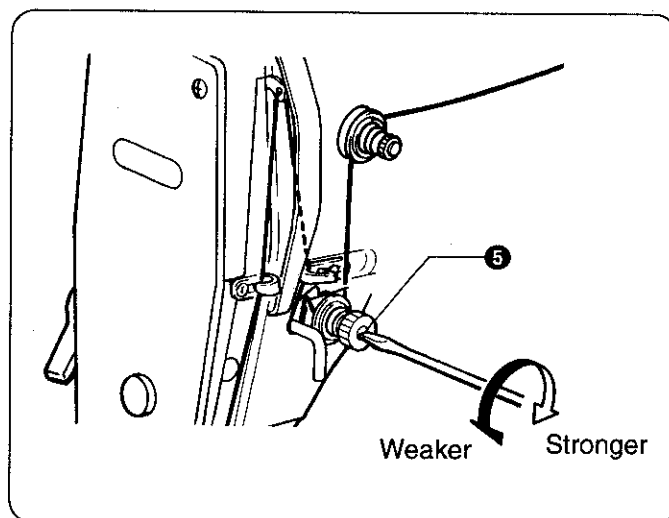

Turn the tension stud ⑤ with a screwdriver.

7. CORRECT USE

7-7. Operating the vibrating bowl

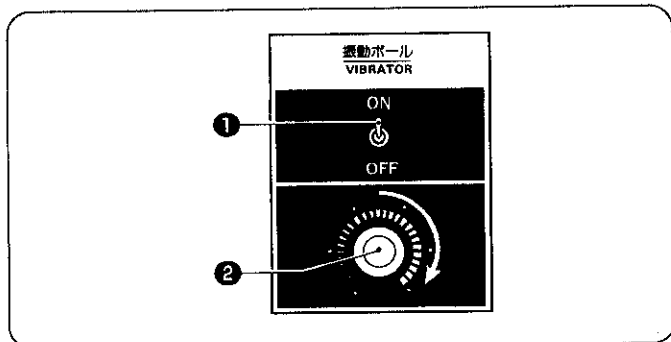

1. Turn the power switch on.
2. Turn the switch ① in the control box on.
3. Turn the adjustment knob ②.
Turn the knob right to increase and left to decrease the amount of vibration of the vibrating bowl.

7-8. Adjusting the vibrating bowl

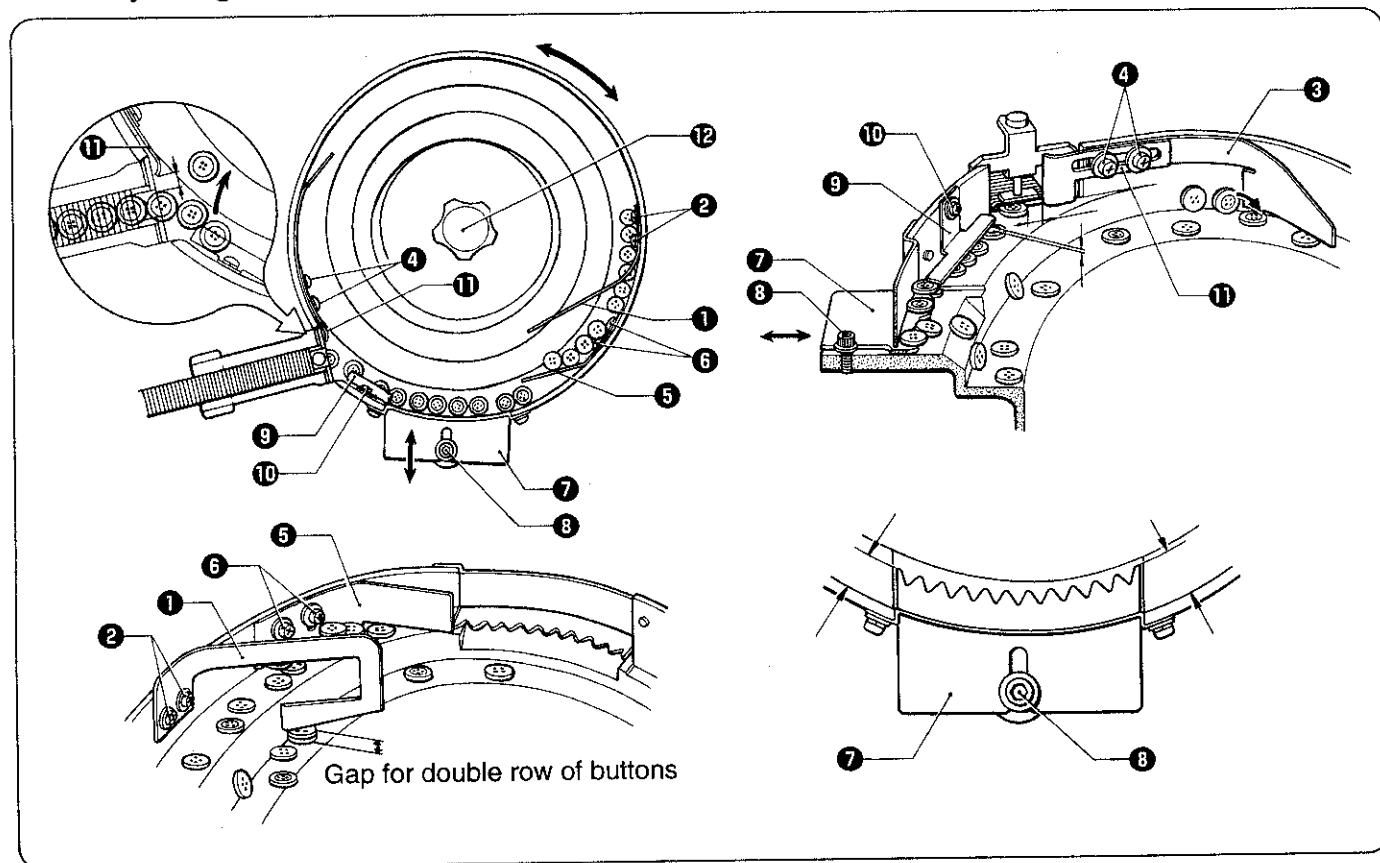

★ The vibrating bowl arranges all of the buttons face up and feeds the buttons to the shooter.

If buttons are not fed properly, check the following.

1. Loosen screw ② and adjust the gap between the bottom of arm B ① and the vibrating bowl so that two buttons can pass.
2. Loosen screw ④ and adjust the gap between the bottom of arm C ③ and the vibrating bowl so that one button can pass.
In addition, the arms should topple any standing buttons to assure a smoother flow.
3. Loosen screw ⑥ and adjust the gap between the bottom of arm A ⑤ and the vibrating bowl so that one button can pass.
4. Loosen bolt ⑧ and move selector plate ⑦ in or out so that the buttons are aligned face up.
5. Loosen screw ⑩ and adjust the gap between the bottom of height control arm ⑨ and the top of the buttons to approximately 0.7 mm.
6. Loosen screw ④ and adjust the button to button width adjustment arm ⑪ gap to approximately 2 mm so that the buttons are fed to the shooter.
7. If buttons become clogged at the entrance to the shooter, loosen screw ⑫ and turn it so that buttons do not clog at the shooter entrance.

* Be sure to readjust the vibrating bowl whenever the buttons are changed.

7-9. Operating the panel switches (button feeder)

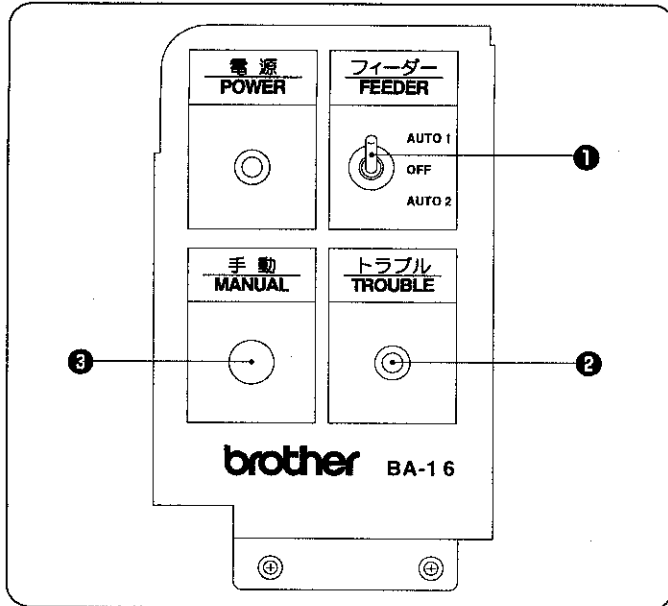

1. Button feeder switch ①
 - AUTO1 ... Buttons are supplied automatically after sewing is complete.
 - AUTO2 ... When sewing is complete and the button clamp releases its button, the next button is supplied.
 - OFF Buttons are not supplied automatically.
2. Trouble indicator ②
 - (1) When buttons are being fed to the button clamp, the trouble indicator ② will be OFF.
 - (2) When the trouble indicator ② is flashing, buttons are not supplied to the button clamp.
 - (3) If the trouble indicator ② is on, a problem has occurred. See below.
3. Manual switch ③
 - ★ Press to feed a button.

Adjustment for excess buttons in the button shooter

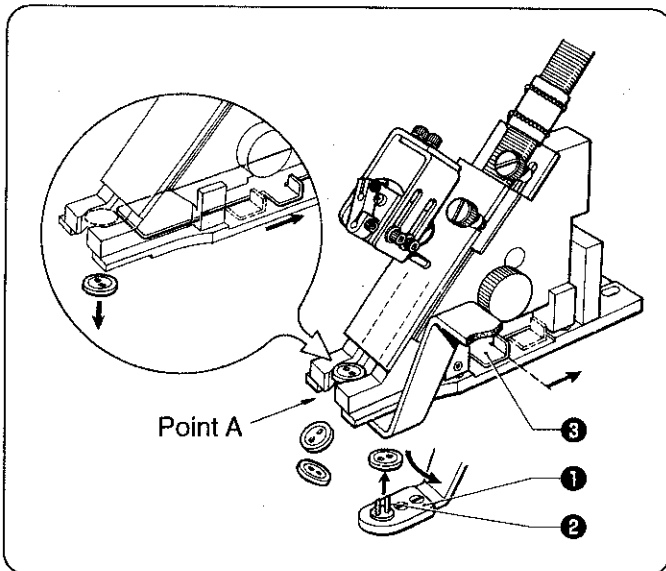

1. Turn the button carrier ① by hand in the direction of the arrow, and remove any buttons from the button carrier pin ②.
2. With the button carrier ① in this position, pull lever ③ to remove any excess buttons from the shooter at point A.
3. Press the manual switch to feed a button to the button clamp.

7-10. Button replacement

7-10-1. Adjustment when the button diameter is changed

1. Slide base adjustment

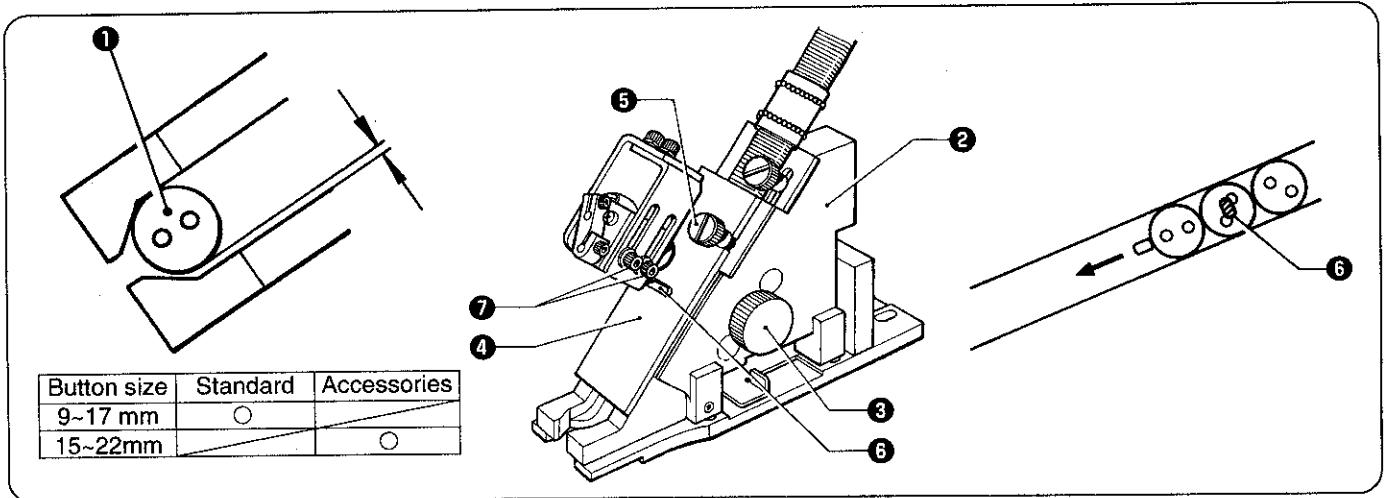

- Adjust the width of the slide base assembly **2** to the button width with slide base screw **3** so that the buttons **1** pass smoothly.
The bed slide base assembly **2** can be adjusted for button diameters of 9 to 22 mm.
Adjust so that the clearance between the buttons **1** and the edge of the slide base assembly **2** is 0.5-1.0 mm.
- There are 3 different button upper covers **4**. The cover for standard button sizes of 9 to 13 mm is factory installed.
To attach buttons from 13 to 22 mm in diameter, loosen screw **5** and replace cover **4** (nonstandard accessories).
- When the button diameter is changed, adjust button stopper A **6** with the adjusting screws **7**. Adjust until stopper A **6** slides into the groove of the upper cover **4** and comes into contact with the second button (position A).

2. Button clamp adjustment

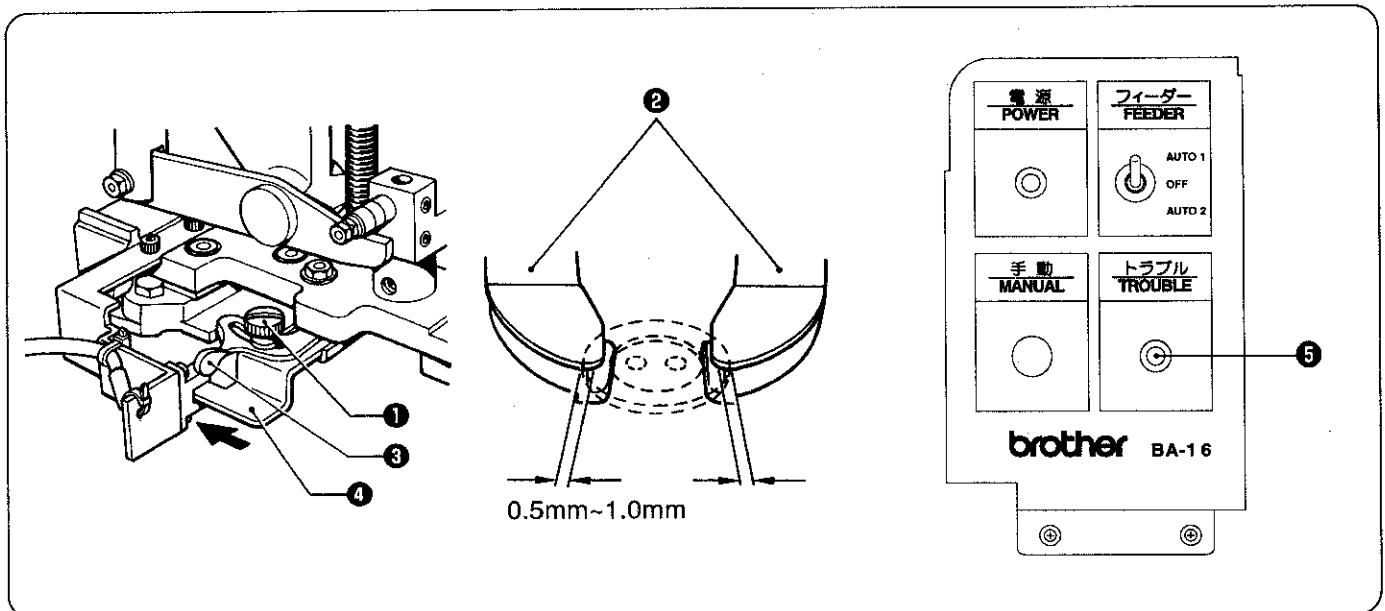

- Loosen step screw **1** and insert a button into the button clamp **2**.
- Lightly tighten step screw **1**, and remove the button.
- Close the button clamp **2** opening 0.5 to 1.0 mm using the plate **3**.
- Firmly tighten step screw **1**.
- After the button is inserted, push the lever **4** slightly in the direction of the arrow to check that the trouble indicator **5** does not blink.

* If the indicator blinks, move slightly and narrow the button clamp **2** opening (mentioned in 3. above).

7-10-2. Adjustment when the button thickness changes

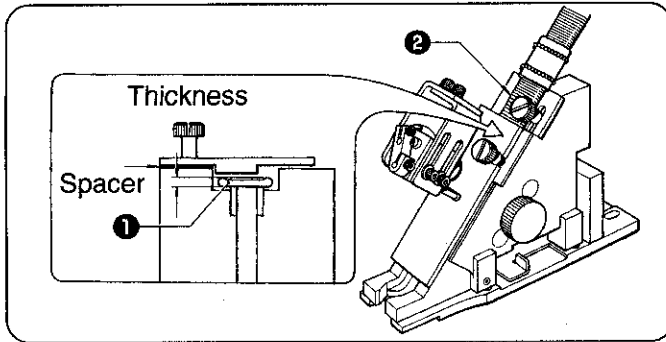

1. Check to be sure that buttons **1** are being smoothly sent to the shooter **2**. If the buttons are not fed smoothly, replace the shooter.
2. Install accessory spacers (0.4 mm, 0.8 mm,) as required by the button thickness.
3. Check to be sure that buttons are being securely grasped by the button clamp.
* If no spacers are used, button thicknesses from 1.8 to 2.2 mm can be used.

7-10-3. If button hole arrangements differ

(Used to change from a two hole button to a four hole button, or from a four hole button to a two hole button.)

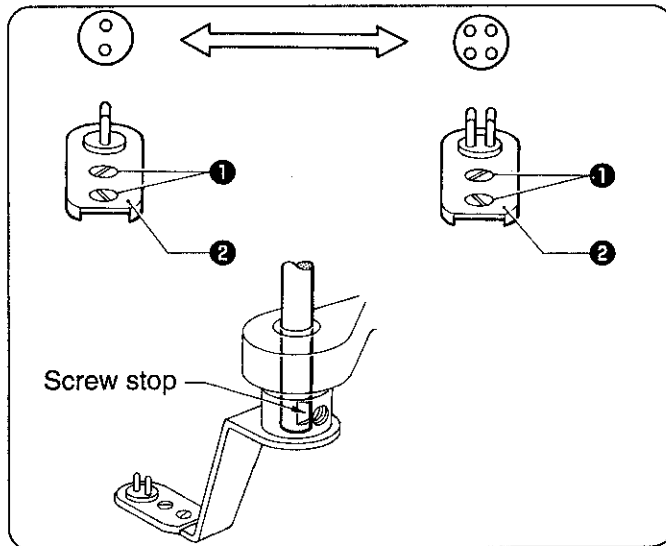

- ★ Loosen screw **1** and replace the button carrier **2**.
- * Adjust the button carrier. (Next page)
- * Adjust the feeder position. (Next page)
- * Adjust the needle position. (See p.31.)

7-10-4. Adjusting the button carrier plate

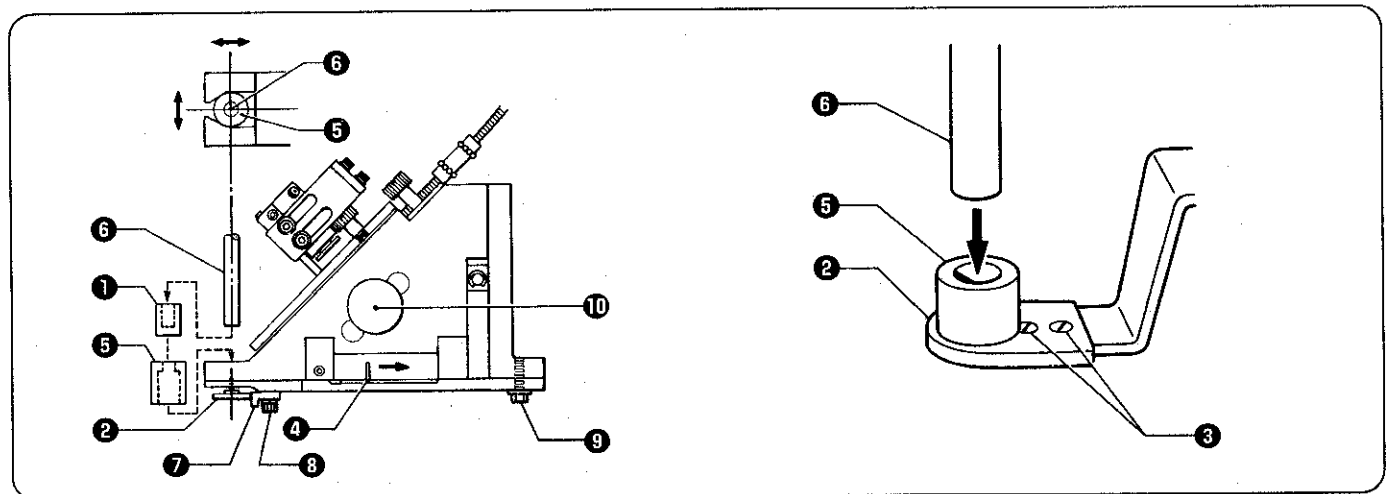

1. Remove the button clamp **1**.
2. Turn the slide base screw **10** to widen the slide base width, then put the gauge **5** on the button carrier plate. Turn the slide base screw **10** and tighten the gauge at the bottom of the slide base.
* At this time, leave the screw **9** and the screw **8** of the stopper **7** loosened.
3. Adjust the slide base so that the shaft **6** fits in the hole of the gauge **5**. Then tighten the screw **9**.
4. With the button carrier plate **2** touching the stopper **7**, tighten the screw **8**.
5. Remove the gauge **5** and insert the shaft **6** into the button clamp **1**.
* This adjustment has already been made at shipping. Therefore, during regular replacement of the button carrier plate, only the replacement procedure described on the this page is necessary.

7. CORRECT USE

7-10-5. Adjusting the feeder position adjustment

* For all programs, the shunting point for the sewing home position point is set to the first stitch position. As long as the button size is not changed, it is not necessary to change the program in order to adjust the feeder position.

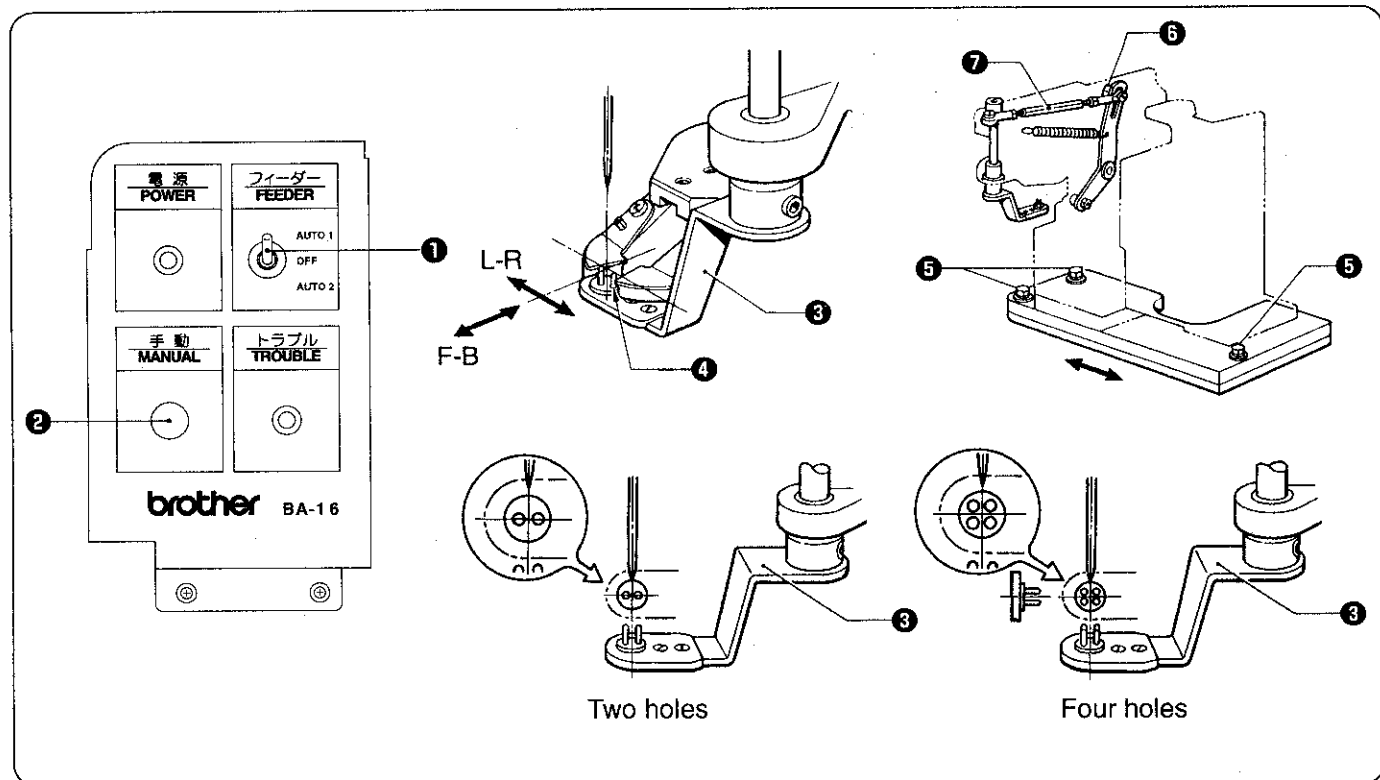

1. Turn on the power switch.
2. Check whether or not the feeder switch ① is AUTO 1.
3. Press and hold manual switch ② and turn the foot switch on. The machine will begin to operate.
The sewing machine will operate in inching mode while the manual switch ② is being pressed, and will stop when the manual switch ② is released.
4. Continue pressing manual switch ② and move button transport arm ③ all the way forward to the needle.
* Assist the button clamp by lifting up.
5. While pushing the button clamp upward, place a button into the button clamp.
6. Check that the button carrier pin is aligned with the hole in the button when the button transport arm ③ is as far forward as it can go (to the needle side).
* The alignment is correct if the pin goes into the hole in the button the pin when the button clamp is moved up and down.
7. If the button carrier pin and hole are not aligned in the left-right direction, loosen the bolt ⑤ and move the entire button feeder assembly to the right or left to adjust.
If they are not aligned in the forward-back direction, loosen the nut ⑥, and move the connecting shaft ⑦ up or down to move the button transport arm ③ forward or back.
After adjustment, press manual switch ② and return button transport arm ③.
* If the button transport arm ③ is not at the home position, error code [E61] may be displayed when the power is turned off and back on again. Be sure to return the button transport arm ③ to the home position.
(Do not turn off the power while doing this.)
* When adjustment is completed, turn the pulley by hand to make sure the needle does not strike the button (needle position adjustment).
8. After adjusting, turn off the power switch and then turn it back on again.
* Wait approximately 5 seconds after turning off the power switch before turning it back on again.

7-10-6. Adjusting the needle location (For □-type needle racking)

- ★ Adjustment is required whenever the button carrier is replaced.
Make sure the needle is not bent.

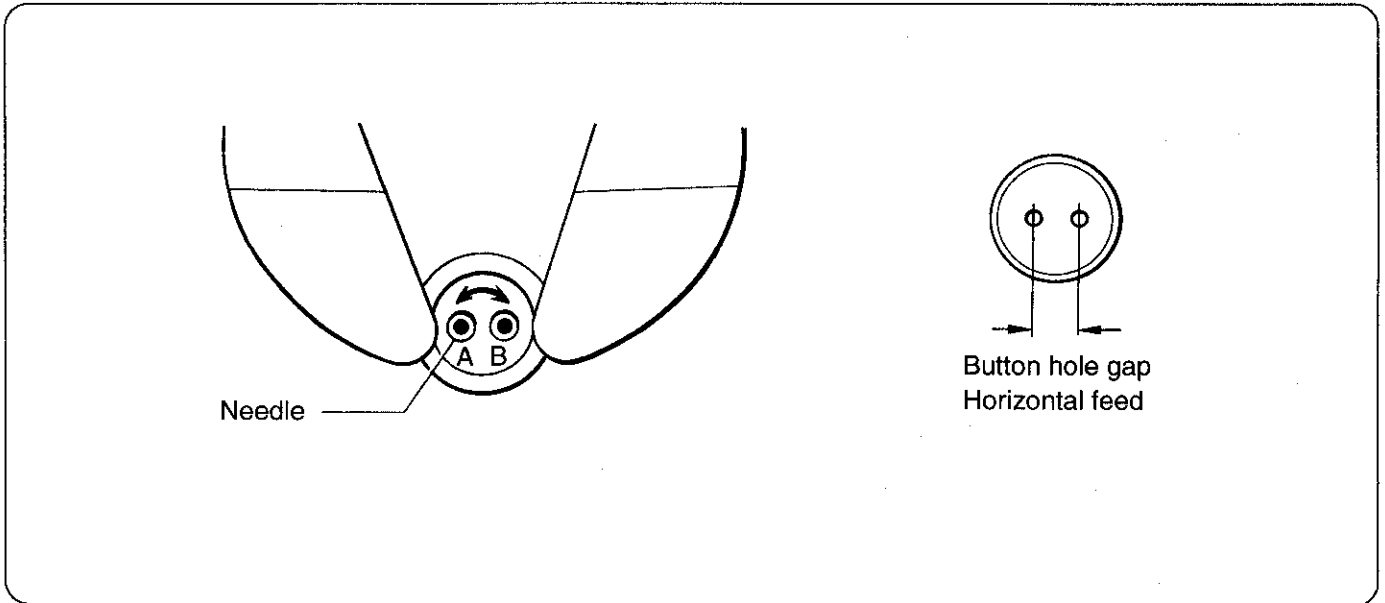
Horizontal feed position

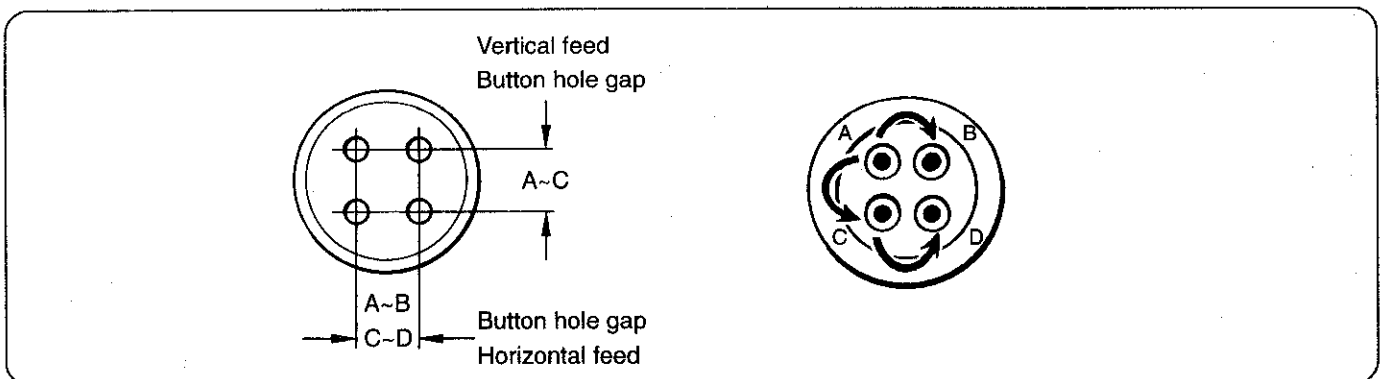

1. Set the X scale so that the holes A and B in the button are aligned with the point of the needle. (Refer to "Setting the X-scale and Y-scale" on page 45.)
2. Check the positions of the button holes. (Refer to "Checking the sewing pattern" on page 21.)

Vertical feed position

1. Set the Y scale so that the holes A and C in the button are aligned with the point of the needle. (Refer to "Setting the X-scale and Y-scale" on page 45.)
2. Check the positions of the button holes. (Refer to "Checking the sewing pattern" on page 21.)

8. SEWING

 **CAUTION**

-  • Turn off the power switch at the following times, otherwise the machine may operate if the foot switch is depressed by mistake, which could result in injury.
 - Threading
 - When replacing the bobbin and needle
 - When not using the machine and when leaving the machine unattended
-  • Do not touch any of the moving parts or press any objects against the machine while sewing, as this may result in personal injury or damage to the machine.

Before starting sewing...

- Check that the needle bar is at its highest position. Turn the machine pulley so that the index mark **1** on the pulley is between the marks **2** on the belt cover.
- * If the machine is started while the index mark **1** is not between these two marks **2**, error message [E-5] will be displayed.

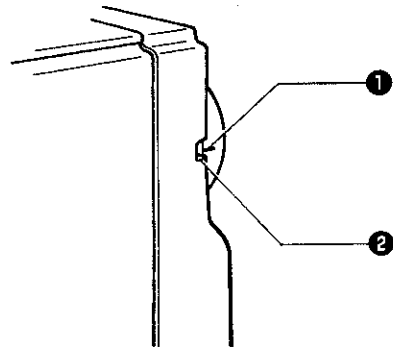

1. Turn on the power switch
(The POWER indicator will illuminate and the program number will flash in the display.)



2. Depress the foot switch to the 2nd step.
(The feed mechanism will move to the starting position and the button clamp will rise.)
* Note that if the foot switch is pressed to the 2nd step while the display is illuminated, the machine will start operating.

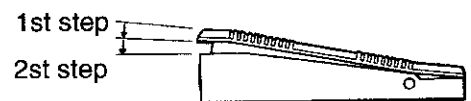

3. Install the button.(Press the MANUAL switch.)



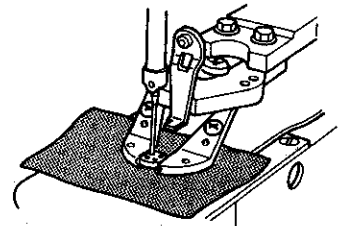

4. Place the material to be sewn under the button clamp, and then depress the foot switch.
When the foot switch is pressed to the 1st step, the button clamp will lower.
If you would like to shift the position of the material, release the foot switch. The button clamp will then rise again.



5. Once sewing is completed and the thread has been trimmed, the button clamp will rise.
* Depending on the sewing data, thread trimming may be carried out or the button clamp may rise during sewing, but the rest of the sewing will still be carried out automatically.

9. MAINTENANCE AND INSPECTION

⚠ CAUTION

- 
 • Turn off the power switch before starting any cleaning work, otherwise the machine may operate if the foot switch is depressed by mistake, which could result in injury.
- 
 • Be sure to wear protective goggles and gloves when handling the lubricating oil and grease, so that they do not get into your eyes or onto your skin, otherwise inflammation can result. Furthermore, do not drink the oil or eat the grease under any circumstances, as they can cause vomiting and diarrhoea. Keep the oil out of the reach of children.

9-1. Cleaning the rotary hook

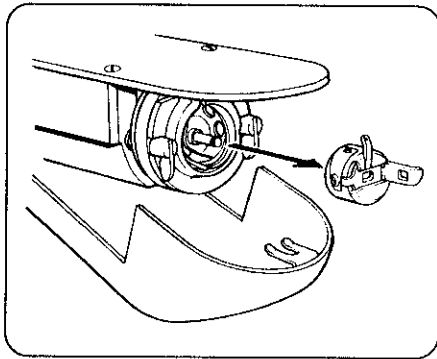

1. Pull the large shuttle hook cover toward you to open it, and then remove the bobbin case.

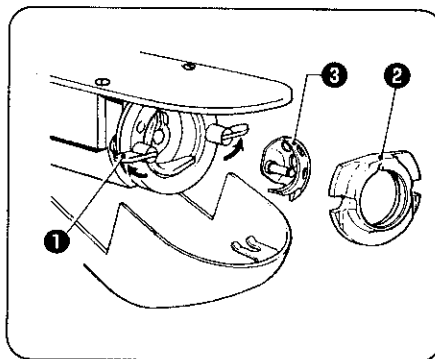

2. Open the large shuttle hook set claw ① in the direction indicated by the arrow, and then remove the large shuttle hook ② and the inner rotary hook ③.

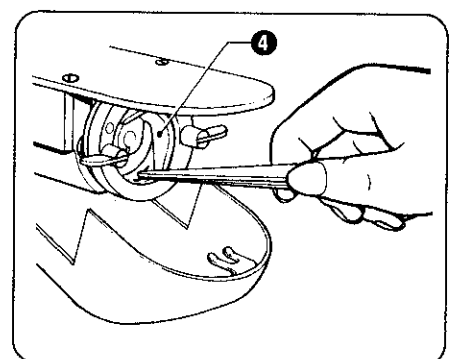

3. Clean all the dust and thread ends from around the driver ④, the top of the rotary hook thread guide and the shuttle race.

9-2. Lubrication

NOTE 1: Fill the machine with oil when the oil level is down to about one-third full in the oil sight glass.

If oil is not added and the oil drops below this level, there is the danger that the machine may seize during operation.

NOTE 2: Be sure to let the machine operate for a while after adding the oil.

NOTE 3: Use only specified Brother oil (Nisseki Sewing Lube 10) for the machine oil.

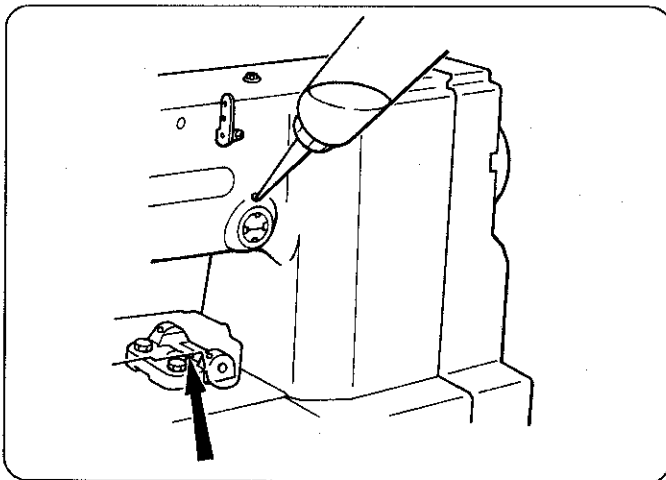

1. Fill the arm-side oil tank with oil.

* When setting up the sewing machine and when it hasn't been used for an extended period of time, be sure to add 2-3 drops of oil at the places indicated by the arrow.

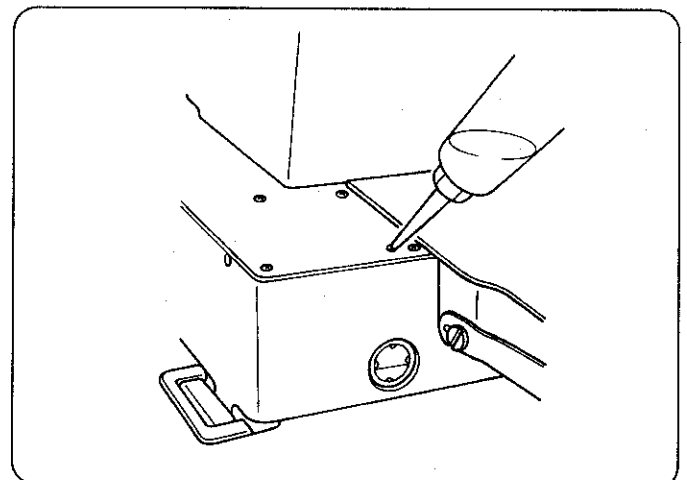

2. Fill the bed-side oil tank with oil.

9-3. Draining the oil

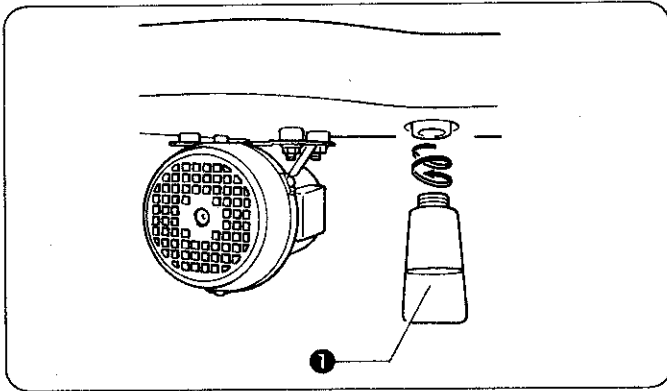

1. Remove and empty the waste oil container **1** whenever it is full.
2. After emptying the waste oil container **1**, screw it back into its original position.

9-4. Cleaning the control box air inlet port

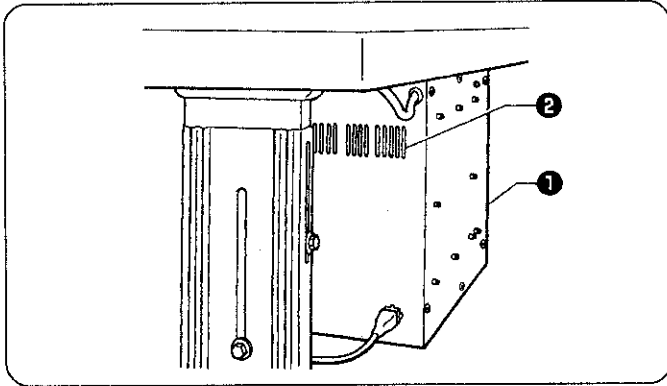

Use a vacuum cleaner to clean the filter in the air inlet port **2** of the control box **1** at least once a month.

* If the machine is used while the air inlet port is blocked, the inside of the control box will overheat.

When this happens, the overheating error code [E-d] will be displayed and you will not be able to operate the sewing machine.

9-5. Cleaning the eye guard

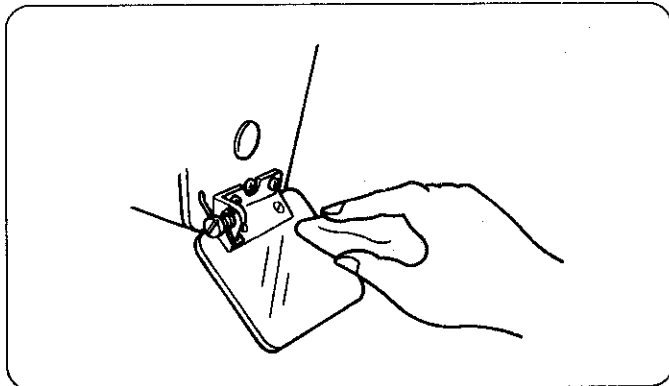

Wipe the eye guard clean with a soft cloth.

NOTE: Do not use solvents such as kerosene or thinner to clean the eye guard.

9-6. Checking the needle

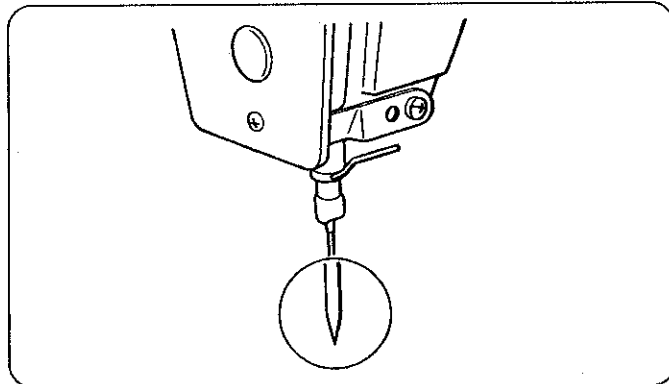

Always check that the tip of the needle is not broken before starting sewing.

10. STANDARD ADJUSTMENTS

⚠ CAUTION

- ⊘ Maintenance and inspection of the sewing machine should only be carried out by a qualified technician.
- ⚠ Ask your Brother dealer or a qualified electrician to carry out any maintenance and inspection of the electrical system.
- ⚠ Turn off the power switch and disconnect the power cord from the wall outlet at the following times, otherwise the machine may operate if the foot switch is depressed by mistake, which could result in injury.
 - When carrying out inspection, adjustment and maintenance
 - When replacing consumable parts such as the rotary hook and knife
- ⊘ Hold the machine head with both hands when tilting it back or returning it to its original position. Furthermore, after tilting back the machine head, do not push the face plate side or the pulley side from above, as this could cause the machine head to topple over, which may result in personal injury or damage to the machine.
- ⚠ If the power switch needs to be left on when carrying out some adjustment, be extremely careful to observe all safety precautions.
- ⚠ If any safety devices have been removed, be absolutely sure to re-install them to their original positions and check that they operate correctly before using the machine.

10-1. Adjusting the needle bar height

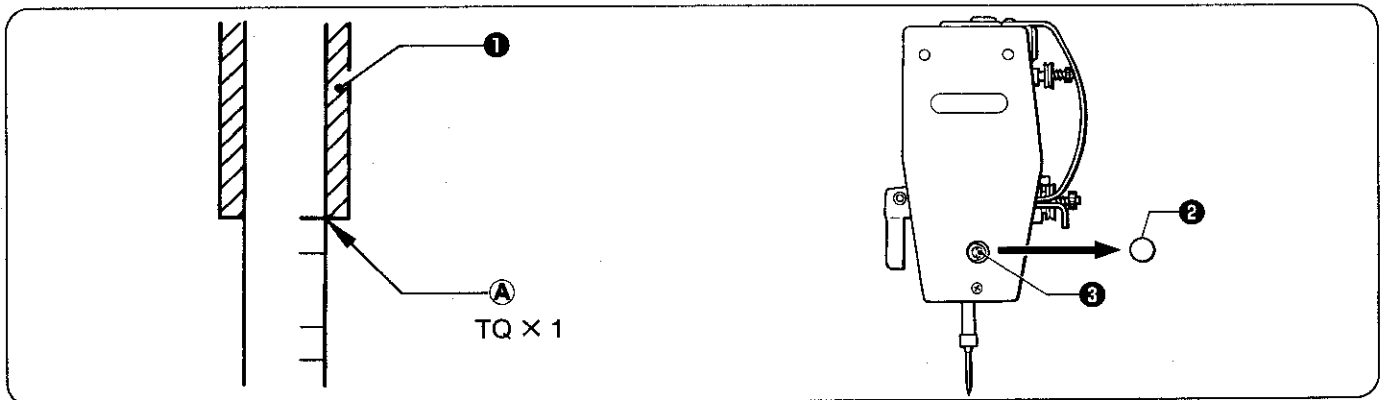

Turn the machine pulley to move the needle bar to the lowest position. Then remove the rubber plug **2**, loosen the screw **3** and then move the needle bar up or down to adjust so that the highest reference line (reference line **A**) is aligned with the lower edge of the needle bar bush **1**.

10-2. Adjusting the needle bar lift amount

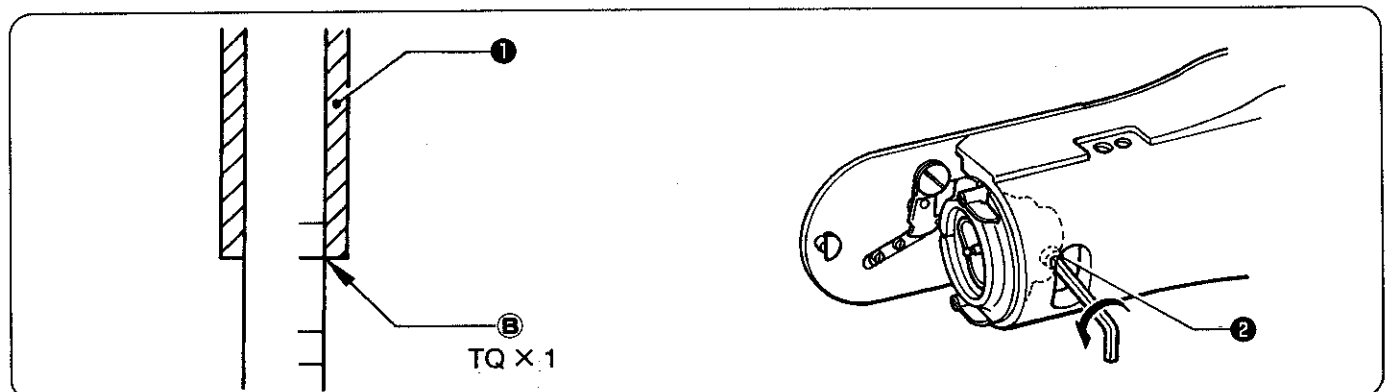

Turn the machine pulley to raise the needle bar from the lowest position until the second reference line from the top (reference line **B**) is aligned with the lower edge of the needle bar bush **1**. Then loosen the screw **2** and move the driver to adjust so that the tip of the rotary hook is aligned with the needle center line.

10-3. Adjusting the driver needle guard

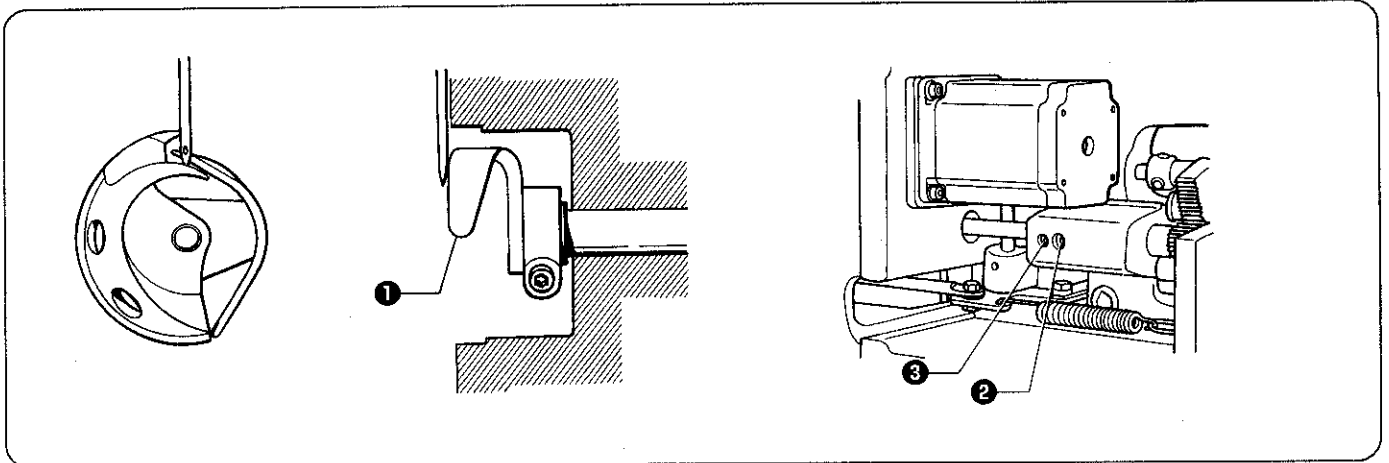

Turn the machine pulley to align the tip of the rotary hook with the needle center line. Then loosen the set screw ② and turn the eccentric shaft ③ to adjust so that the driver needle guard ① contacts the needle. If the needle contact pressure is too great, skipped stitches may occur. On the other hand, if the driver needle guard ① is not touching the needle, the tip of the inner rotary hook will obstruct the needle, resulting in an excessively high amount of friction.

10-4. Adjusting the needle clearance

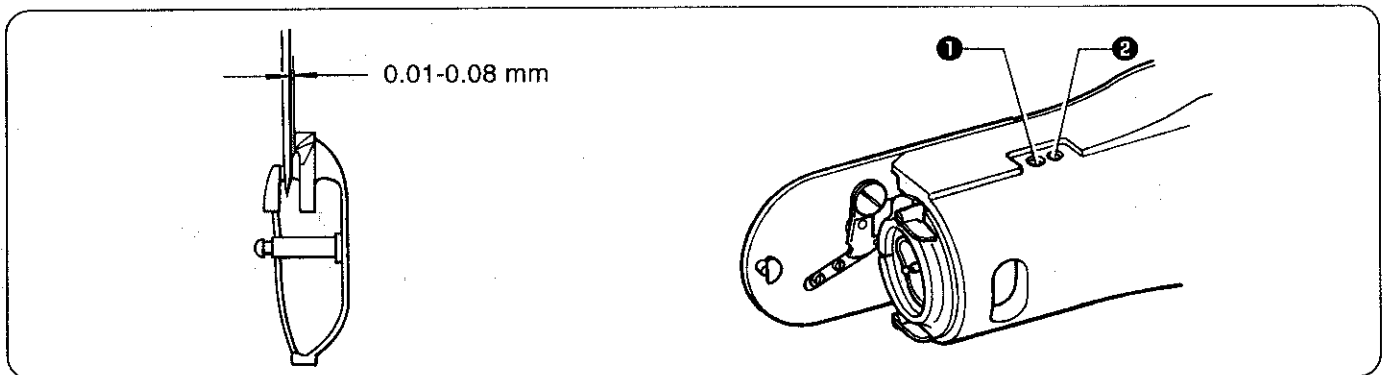

Turn the machine pulley to align the tip of the rotary hook with the needle center line. Then loosen the set screw ① and turn the eccentric shaft ② to adjust so that the clearance between the needle and the rotary hook is 0.01-0.08 mm.

10-5. Adjusting the shuttle race thread guide

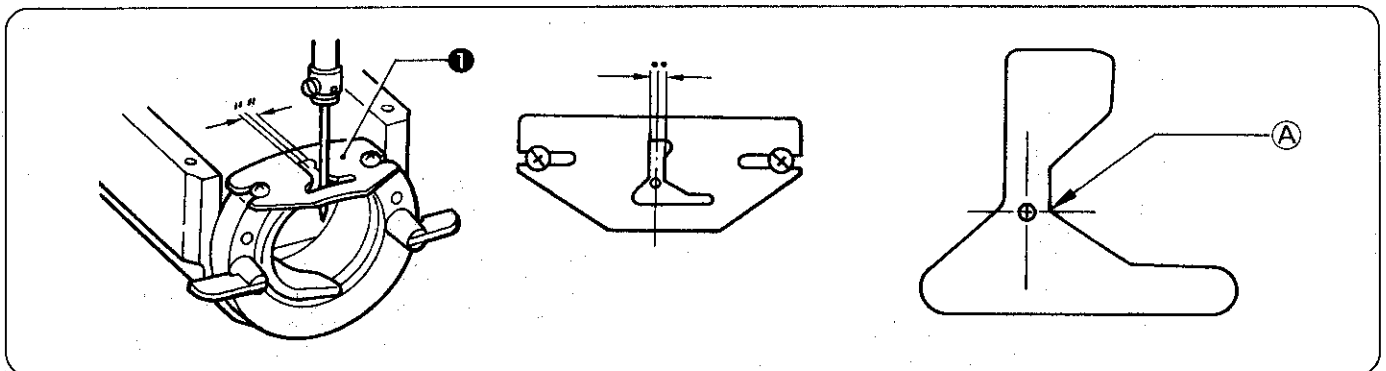

The needle groove of the shuttle race thread guide ① should be aligned with the center of the needle plate hole, and the needle center and the angled section A should be aligned.

NOTE: If the shuttle race thread guide is in the wrong position, thread breakages, soiled thread or catching of the thread may occur.

10-6. Adjusting the movable knife

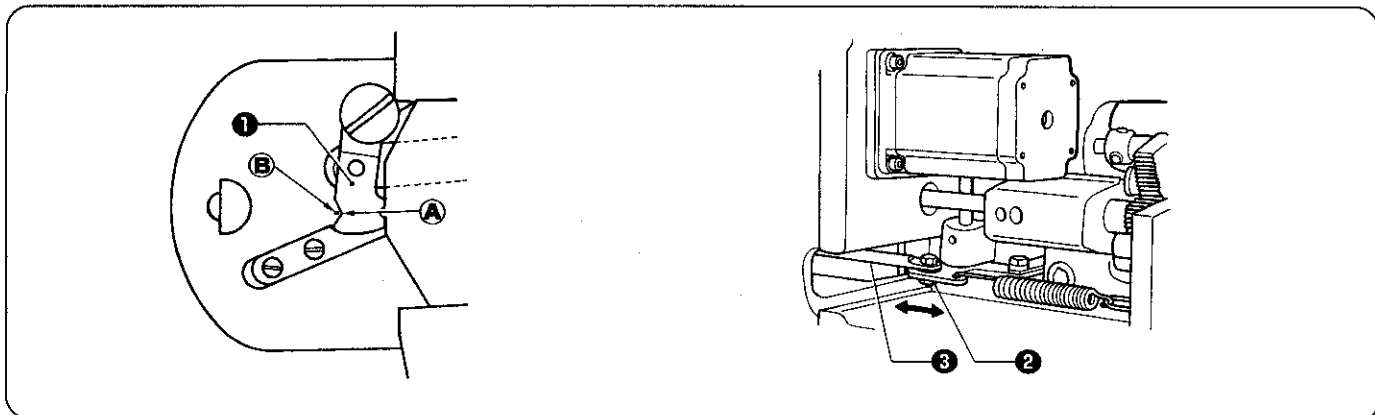

Loosen the nut **2** and move thread trimmer rod L **3** to the left or right to adjust so that the V section **A** of the movable knife **1** is aligned with the index mark **B** on the needle plate when the machine is at the stop position.

<Replacing the movable knife and fixed knife>

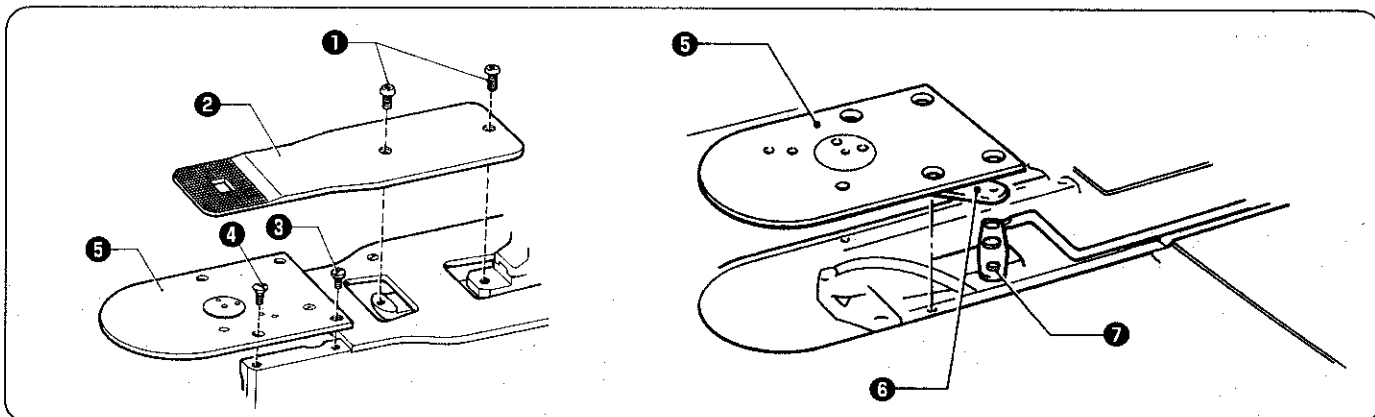

1. Open the large shuttle hook cover, remove the screw **1**, and then remove the feed plate **2**.
2. Remove the two screws **3** and the two screws **4**, and then remove the needle plate **5**.
3. Remove the thread trimmer connecting rod **6** from the connecting rod lever pin **7**.

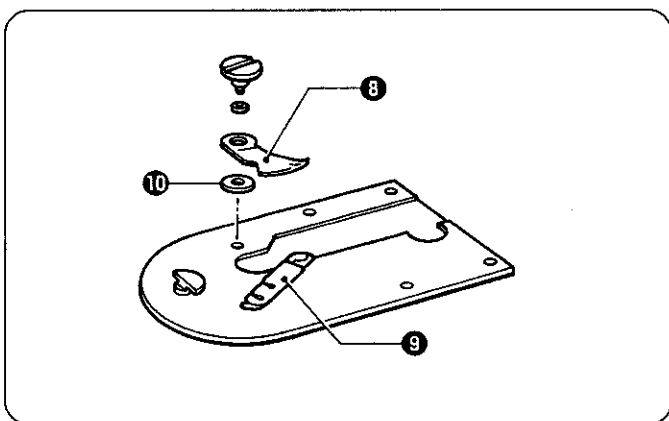

4. Remove the movable knife **8** and replace it with a new one. At this time, check that the movable knife **8** and the fixed knife **9** cut the thread cleanly. If necessary, adjust by using the appropriate movable knife washer **10** (supplied as accessories).

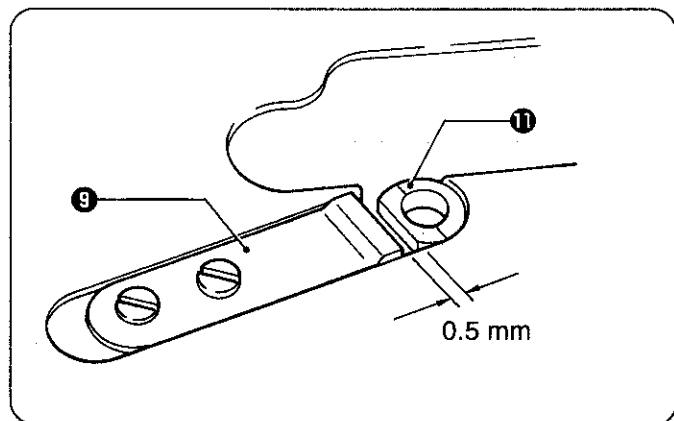

5. Install the fixed knife **9** at a distance of 0.5 mm from the needle hole plate **11**.
6. Place the thread trimming connecting rod **6** onto the connecting rod lever pin **7**, and then install to the needle plate **5**.

10. STANDARD ADJUSTMENTS

10-7. Adjusting the button clamp lift amount

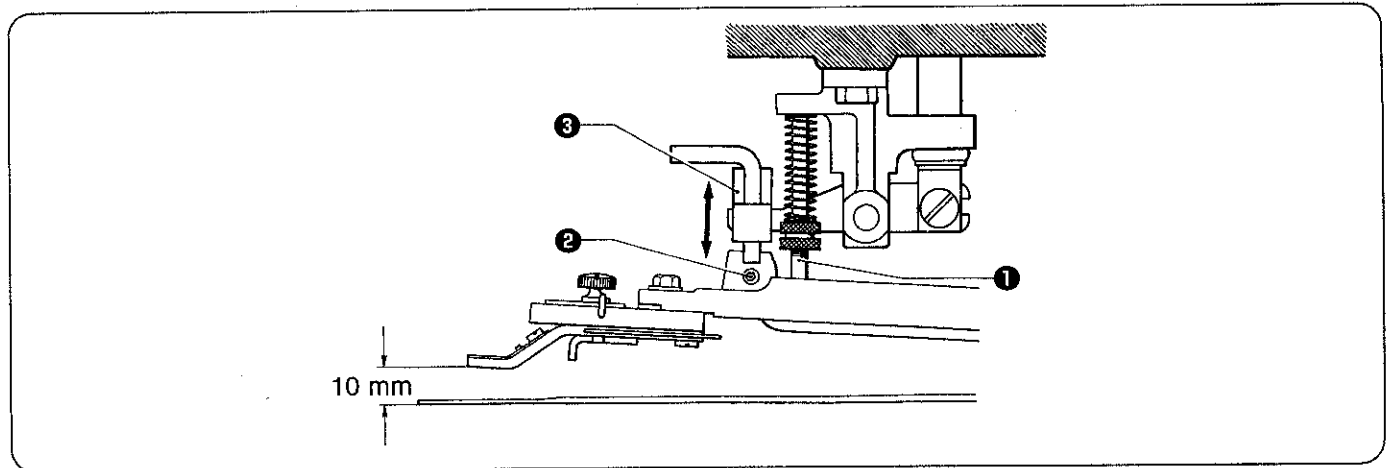

The maximum button clamp lift amount is 13 mm from the top of the needle plate. (The lift amount is adjusted 10 mm at the time of shipment.)

To adjust the button clamp lift amount, remove the button clamp presser spring ①, loosen the screw ② and adjust the button clamp holder hook ③ by moving it up and down.

* If movement is sluggish when the button clamp is being raised and lowered, it may not be possible to increase the button clamp lift amount.

* If the button clamp cannot be raised or lowered, error code [E-6] will be displayed.

10-8. Adjusting the holding pressure

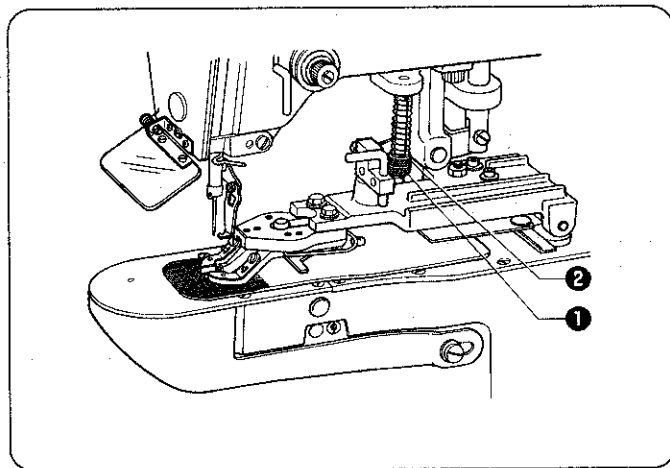

Loosen screw ① and turn adjustment screw ② so that clamp pressure is as light as possible but high enough so that the material will not slip when pulled lightly.

* If the clamp pressure is too high, the buttons may not be fed properly.

10-9. Adjusting the button clamp height

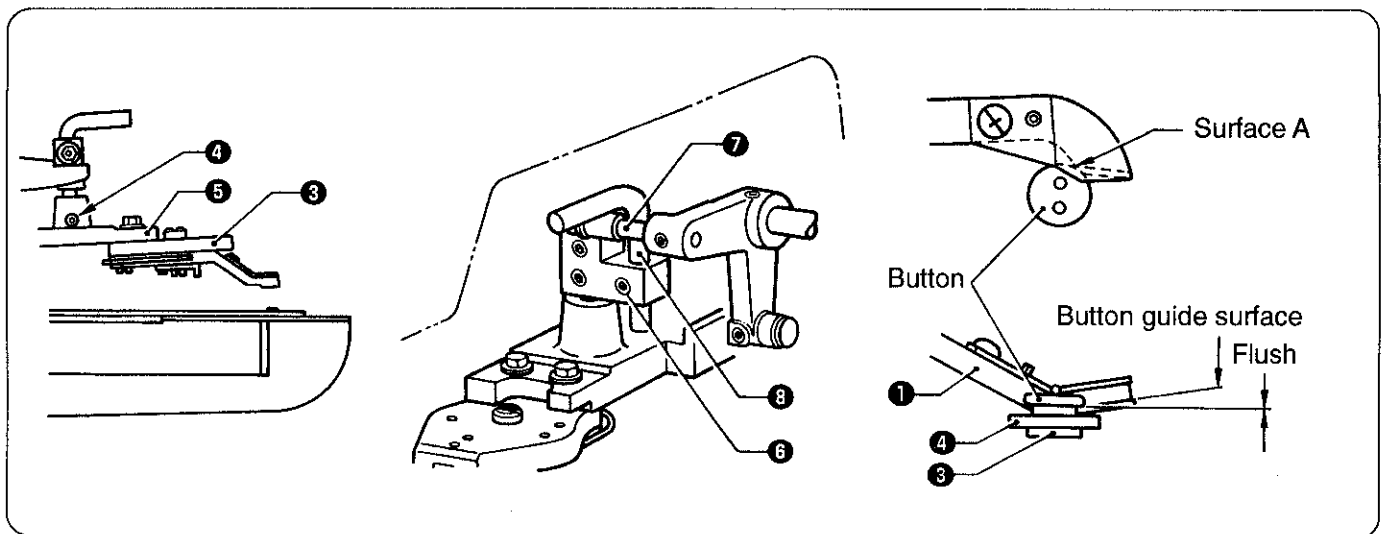

Adjustment

1. After turning on the power switch, turn AUTO 1 or AUTO 2 the feeder switch.
2. The button carrier will move slowly if the foot switch is turned on with the manual switch depressed.
The sewing machine will operate in inching mode while the manual switch is being pressed, and will stop when the manual switch is released.
3. Stop machine inching when button transport arm ① moves and the button is at button guide surface A.
4. Make sure that top of button carrier ② is flush with the button guide surface of button clamp ③.
If they are not properly aligned loosen screw ④ and move button clamp holder ⑤ up or down.
5. Loosen screw ⑥, set presser bar lifter hook A ⑦ against presser bar lifter roller arm ⑧, and tighten screw ⑥.
* Lift button clamp ③ by hand when button transport arm ① is being inched forward.
* Press the manual switch to return the button transport arm ① when the adjustment is completed.
6. Turn off the power to cancel inching operation.

10-10. Adjusting the thread wiper

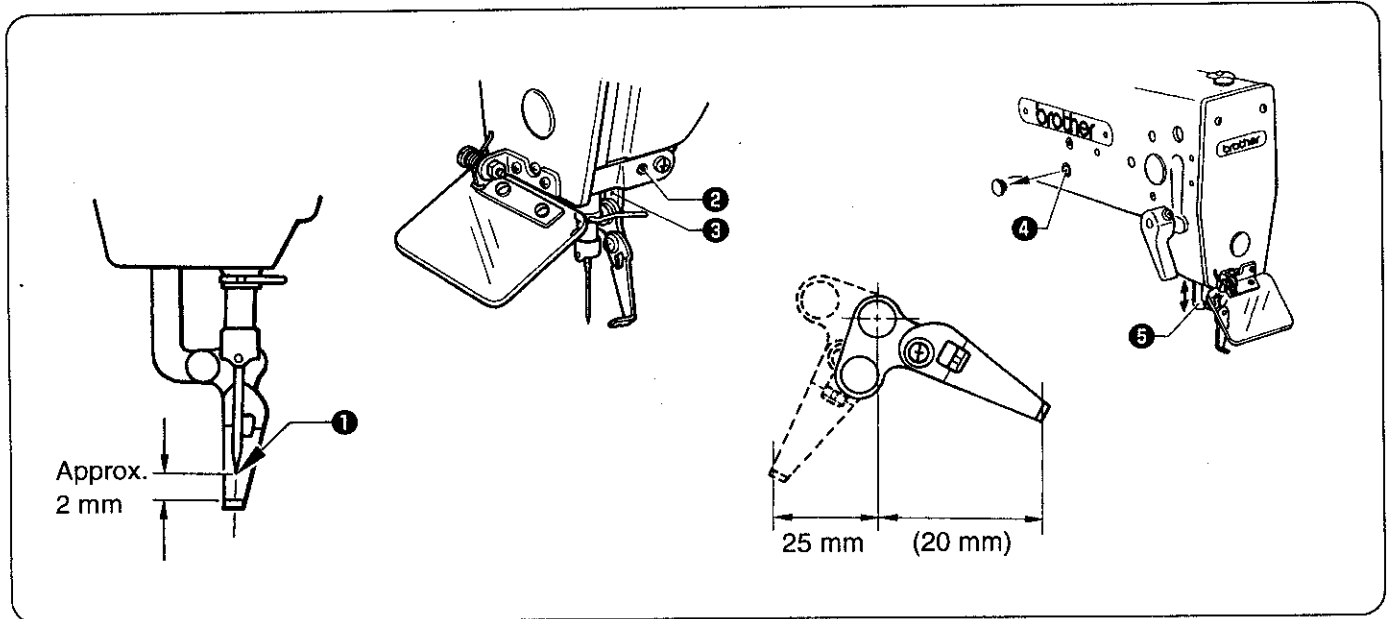

1. Loosen the set screw ② and then move the wiper arm support ③ up or down to adjust so that there is a clearance of approximately 2 mm between the top of the thread wiper and the point of the needle ① when the thread wiper passes the point of the needle.
2. Loosen the screw ④ and move the thread guide connecting plate ⑤ up or down to adjust so that the thread wiper is approximately 25 mm from the needle when it is wiping the thread.

10-11. Adjusting the needle up stop position

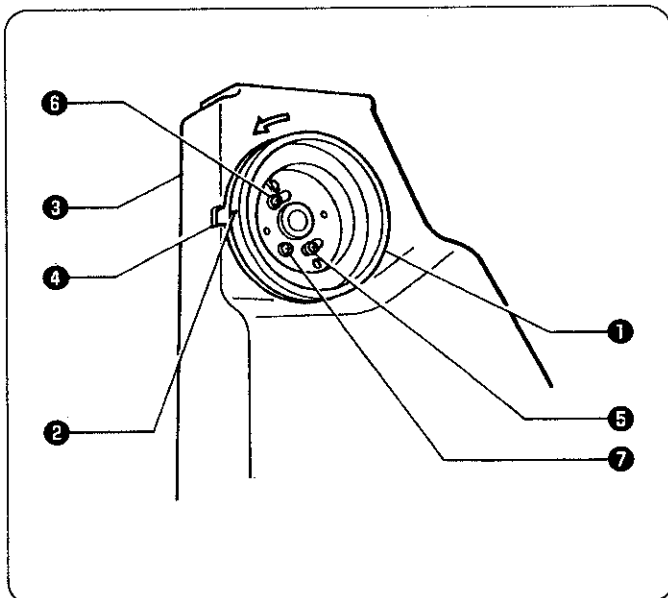

The needle up stop position is adjusted so that the index mark ② on the machine pulley ① is inside the mark ④ on the belt cover ③.

If adjustment is necessary, loosen the screw ⑤ at the "U" mark of the machine pulley ① and adjust the position of the machine pulley ①. The machine pulley ① stops later if it is turned clockwise, and it stops earlier if it is turned counterclockwise.

* The screw ⑥ at the "D" mark is an adjustment screw for the needle down detection function and is adjusted to match the feed timing, so it should not be loosened.

* The screw ⑦ is a screw for detecting the machine stop position, and should not be loosened.

* If the index mark ② is not inside the mark ④ when the sewing machine is started, error code [E-5] will be displayed. Turn the machine pulley to move the index mark ② to the correct position and then start the sewing machine.

10-12. Checking the input sensors

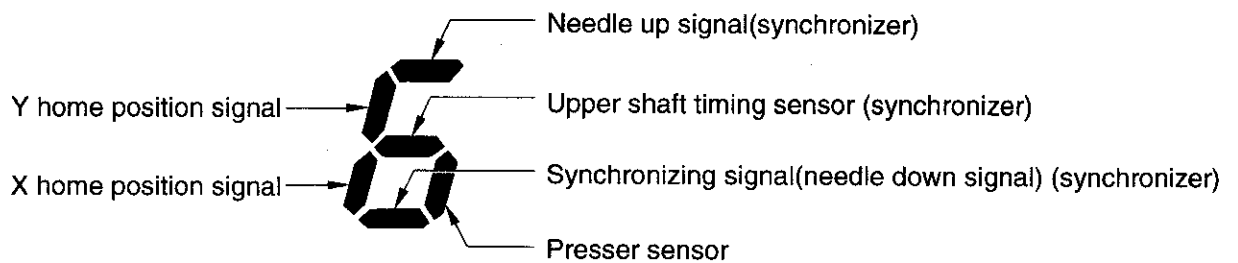

1. Turn on the power switch.
2. Press the menu switch until the X-SCALE indicator illuminates.
3. While pressing the TEST switch, press the RESET switch.
4. The conditions of the various input sensors will be shown in the first digit display area of the display as indicated above.
5. Press the TEST switch once more to return the display to the normal condition.

Display conditions

Y home position sensor :	Illuminates when at the home position
X home position sensor :	Illuminates when at the home position
Needle up signal :	Illuminates when the needle is raised
Upper shaft sensor :	Illuminates when a signal is being input
Synchronizing signal :	Illuminates when the needle is lowered
Presser sensor :	Illuminates when the presser is lowered

10-13. Checking the input voltage

1. Turn on the power switch.
2. Press the menu switch until the Y-SCALE indicator illuminates.
3. While pressing the TEST switch, press the RESET switch.
4. The input voltage conditions will be shown in the display.
* The voltage values are expressed as a percentage (100% when 200 V is supplied to the power supply circuit board).
5. Press the TEST switch once more to return the display to the normal condition.

[When a normal voltage is input]

200-V specifications	[090]-[110]
220-V specifications	[100]-[120]
230-V specifications	[105]-[125]
100-V, 380-V, 400-V and 415-V specifications	[100]-[120]

10. STANDARD ADJUSTMENTS

10-14. Moving stitch patterns

NOTE:

The operations below are for test purposes and should not be carried out during normal sewing, as they could stop the button feeder from operating at the correct timing.

- Programs which have already been programmed can be moved up, down and to the left and right.
(However, such patterns will be reset if the power supply is turned off or the program number is changed.)
- The feed position can be set to the any position desired.

1. Moving a stitch pattern

(1) Select the program number, and then press the start switch once to move the feed mechanism to the sewing start position.

(2) While pressing the TEST switch ③, press the RESET switch ②.

The TEST indicator ④ will illuminate and < 000 > will appear in the display window ⑫.

(3) Press the MENU switch ⑥ so that either the X-SCALE indicator ⑧ or Y-SCALE indicator ⑨ illuminates.

(4) Turn the setting dial ⑪ to move the feed mechanism one pulse at a time.

- ① If the setting dial is turned counterclockwise while the X-SCALE indicator is illuminated, the feed mechanism will move to the right.
- ② If the setting dial is turned clockwise while the X-SCALE indicator is illuminated, the feed mechanism will move to the left.
- ③ If the setting dial is turned counterclockwise while the Y-SCALE indicator is illuminated, the feed mechanism will move up.
- ④ If the setting dial is turned clockwise while the Y-SCALE indicator is illuminated, the feed mechanism will move down.

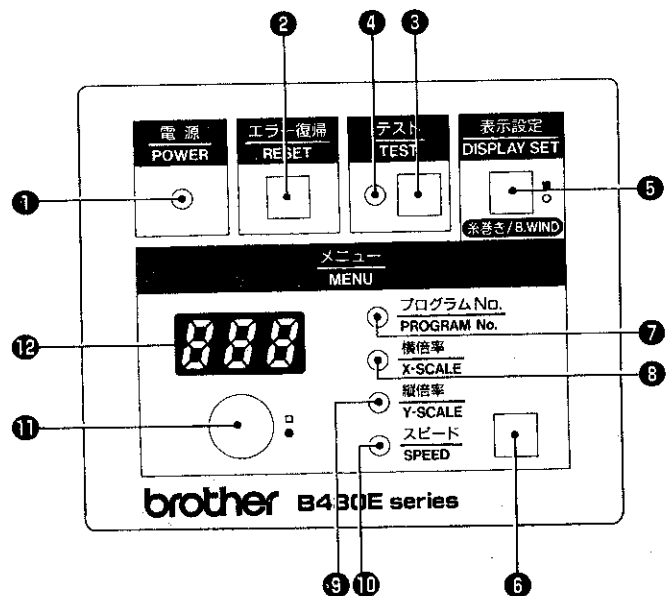

(5) When the TEST switch ③ is pressed after the above fine adjustments have been made, the TEST indicator ④ and display window ⑫ will both switch off and movement of the stitch pattern will be completed. (*1)

2. Moving the feed mechanism to the desired position (feed test)

- (1) Same as 1-(2).
- (2) Same as 1-(3).
- (3) Same as 1-(4).
- (4) Same as 1-(5).

(*1) When moving the stitch pattern, the sewing start position can be moved to any desired point within the sewing area, but if the pattern goes outside the sewing area, an error will occur during sewing and you will not be able to sew the pattern. Give consideration to the pattern as a whole when moving it.

11. CHANGING FUNCTIONS USING THE DIP SWITCHES

11-1. Operation panel DIP switches

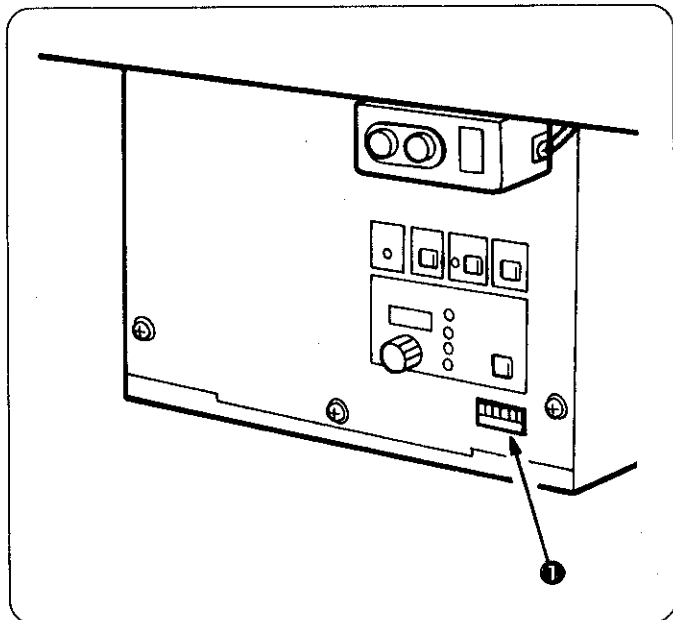

The operation panel DIP switches ① are used to change functions which might need to be changed depending on the sewing conditions.

Caution: Always turn off the power before setting the DIP switches.

The functions shown in the table below can be changed by means of these DIP switches.

* All DIP switches are set to OFF at the time of shipment.

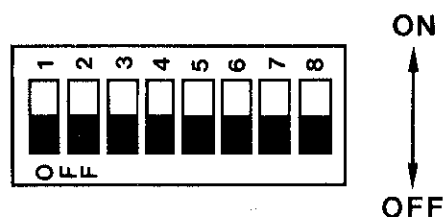

Switch	Motion when set to ON	
DIP A-1	Presser does not automatically lift after sewing is completed.	See "11-2. Setting the presser mode".
DIP A-2	Two-pedal mode is available.	
DIP A-3	User program mode is available.	
DIP A-4	Option panel mode is available.	
DIP A-5	The presser does not rise automatically when a split is found.	
DIP A-6	First three stitches are sewn at a low speed of 400 spm.	
DIP A-7	Enlargement of pattern size is not available.	
DIP A-8	Program number is fixed.	

※ The split is the sewing operation of the pattern subdivided into smaller portions by one program No.

11-2. Setting the presser mode

Through the combination of DIP switches A-1 and A-2 on the operation panel, presser motions can be set as follows:

DIPA-1	DIPA-2	Pedal specifications	Raising the presser at the sewing end
—	—	Single pedal	Presser is raised automatically.
ON	—	Single pedal	Presser is raised by pressing the pedal.
—	ON	Two pedals	Presser is raised automatically, then it is lowered by pressing the pedal.
ON	ON	Two pedals	Presser is kept lifted while the pedal is pressed.

11. CHANGING FUNCTIONS USING THE DIP SWITCHES

11-3. DIP switches inside the control box

⚠ DANGER



- Wait at least 5 minutes after turning off the power switch and disconnecting the power cord from the wall outlet before opening the face plate of the control box. Touching areas where high voltages are present can result in severe injury.

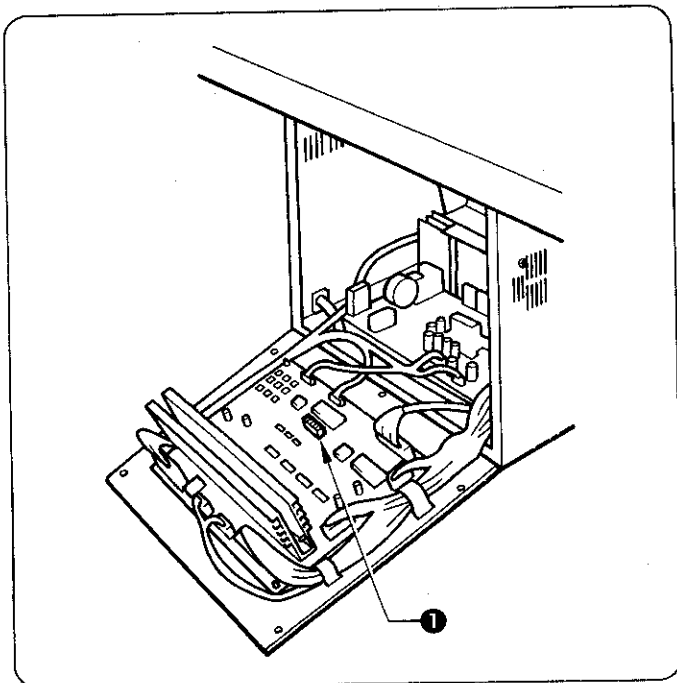

The DIP switches ① inside the control box are used to change functions which do not often need to be changed once they have been set.

The functions can be changed as shown in the table below by changing the positions of the DIP switches ①.

* All DIP switches are set to OFF at the time of shipment.

Caution: When opening the cover, hold it securely so that it does not fall down.

Switch	Motion when set to ON
DIP B-1	First two stitches are sewn at a low speed of 260 spm.
DIP B-2	Last two stitches are sewn at a low speed of 260 spm.
DIP B-3	Last two stitches are sewn at a low speed of 400 spm regardless of the pattern. *1
DIP B-4	— *2
DIP B-5	— *2
DIP B-6	Low speed sewing is not performed at the start of sewing.
DIP B-7	— *2
DIP B-8	Sets the sewing area to an unlimited area.

*1 When the DIP switch Nos. 2 and 3 are all off, last two stitches will be sewn at about 400 spm.

*2 DIP switches B-4, B-5 and B-7 are spare switches, and should always be set to OFF.

11-4. Using user programs

User program...

It can store seven different programs (designated as A, b, c, d, E, F, and H) which can include details such as the program number, X-scale, Y-scale and sewing speed. If you are sewing certain patterns over and over again, it is useful to record the settings for these patterns into a user program.

Recording a user program

1. Turn off the power switch and then set DIP switch 1 to ON.



2. Turn on the power switch. While pressing the TEST switch 2, press the menu switch 3.

* All of the menu indicators (4 to 7) will illuminate and the mode will switch to recording mode.
 * In addition, "P A" will appear in the display 8 to indicate that user program A is being recorded. (Once recording of A is completed, b will be displayed; once b is completed, c will be displayed. Thus the next unrecorded program letter is always displayed.)



3. Press the menu switch 3.
 * The PROGRAM No. indicator 4 will illuminate.



4. Turn the rotary switch 9 to select the number for the program that you would like to record.



5. Press the menu switch 3. * The X-SCALE indicator 5 will illuminate.



6. Turn the rotary switch 9 to select the X-scale setting that you would like to record.



7. Press the menu switch 3. * The Y-SCALE indicator 6 will illuminate.



8. Turn the rotary switch 9 to select the Y-scale setting that you would like to record.



9. Press the menu switch 3. * The SPEED indicator 7 will illuminate.



10. Turn the rotary switch 9 to select the sewing speed setting that you would like to record.

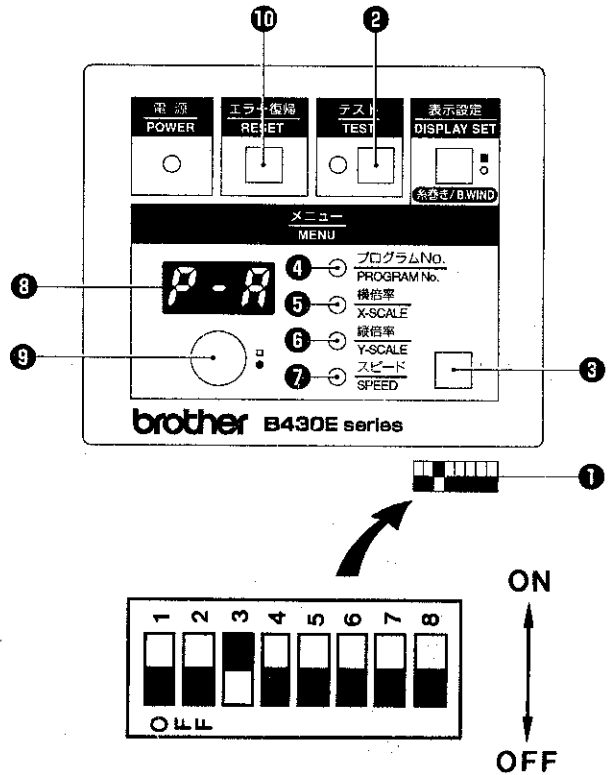

11. CHANGING FUNCTIONS USING THE DIP SWITCHES

11. Press the menu switch ③.

- * This completes the recording of user program A.
- * "P b" will then appear in the display ⑥, to indicate that user program b is now being recorded.
- Repeat steps 3. through to 11. to record further programs as desired.





12. Press the TEST switch ②. This completes the recording.

- * The menu indicators ④ to ⑦ will all illuminate and " A" will appear in the display to indicate that user program A is currently selected.
- * If the TEST switch ② is pressed before recording is completed, the current user program will not be recorded.

Using a user program

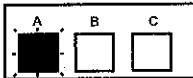
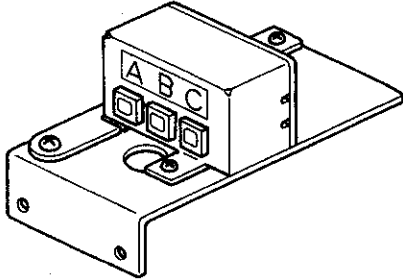
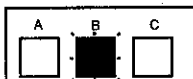
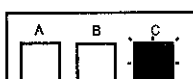
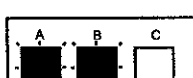
1. While pressing the DISPLAY SET/B.WIND switch, turn the rotary switch ⑨ to select the program number for the user program that you would like to use.
2. Depress the foot switch to the second step.
3. Check the sewing pattern (see P.21), and then sew the pattern selected.

* In addition, you can use the optionally-available handy switch ⑩ to quickly and conveniently switch between the user programs which have been recorded.

To select A		Press switch A; indicator A will illuminate.	
To select b		Press switch B; indicator B will illuminate.	
To select c		Press switch C; indicator C will illuminate.	
To select d		Press switches A and B simultaneously; indicators A and B will illuminate.	
To select E		Press switches B and C simultaneously; indicators B and C will illuminate.	
To select F		Press switches A and C simultaneously; indicators A and C will illuminate.	
To select H		Press switches A, B and C simultaneously; indicators A, B and C will illuminate. If switches A, B and C are pressed simultaneously when DIP switch A-4 is set to ON, the option switches can then be used to carry out some of the functions of the operation panel.	

Clearing the user programs

1. Switch the machine to recording mode by the procedure in steps 1. and 2. of recording a user program.
2. Press the RESET switch ⑩.
All of the user programs which have been recorded will then be cleared.

12. CHANGING THE MODE OF THE HANDY SWITCH (OPTION)

The handy switch is equipped with two operation modes: in one mode, the switch changes over user programs, and in the other mode, is an option panel mode in which the switch operates in the same way as some of the switches on the operating panel.

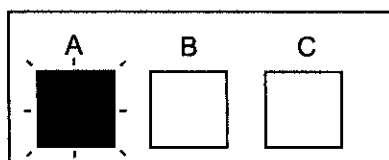

User program mode

The switches illuminate in accordance with the modes from A-H.

If switches A, B and C are pressed simultaneously when DIP switch A-4 is set to ON, "H" will be selected.

[Changing the mode]

The mode is switched by pressing buttons A, B and C simultaneously.

The operation achieved by pressing switches A, B and C simultaneously can be changed by means of DIP switch A-4.

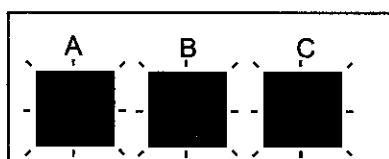

Option panel mode

All three switches illuminate.

(If switches A, B and C are pressed simultaneously when DIP switch A-4 is set to on)

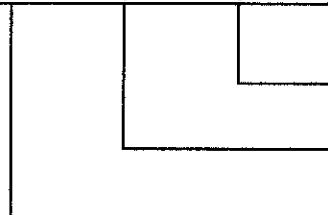

Thread winding

Thread trimming and step back

Error resetting

A. Error resetting

The handy switch operates in the same way as the error reset switch on the operating panel.

B. Thread trimming and step back

When the emergency stop switch is pressed in the middle of sewing a pattern, you can continue sewing that pattern from the point where the emergency stop switch was pressed. The method of operation is as follows.

1. Press the emergency stop switch during sewing of a pattern.
2. Turn the emergency stop switch clockwise to unlock it, and then press the error reset switch (switch A).
3. Press the thread trimming/step back switch (switch B) once to trim the thread.
(If the external solenoid wiper is installed, the wiper will also operate.)
4. After this, the sewing position will move back one stitch at a time each time the switch is pressed. Once you reach the desired position, depress the start switch to sew the remaining part of the pattern.

* This function is also available by using the DISPLAY SET/B.WIND switch on the operating panel.

C. Thread winding

When winding the lower thread, operation is the same as the DISPLAY SET/B.WIND switch on the operating panel.

13. CHANGING SPECIAL FUNCTIONS USING THE MEMORY SWITCHES

The functions of the switches on the operation panel ① can be changed to carry out special functions.

* All of the memory switches except for memo-5, and 8 are set to OFF at the time of shipment.

1. Turn on the power switch.
2. While pressing the TEST switch ②, press the DISPLAY SET/B.WIND switch ③.
3. "0--" will appear in the display ④.
4. When the DISPLAY SET/B.WIND switch ③ is pressed, the two spaces at the right in the display window will change from "--" to "on".
5. If this switch is pressed once more, the display will change from "on" to "--".

* If the RESET switch ⑥ is pressed at this time, all memory switches except for memo-5, and 8 will be reset to the "off" setting. (The memo-5, and 8 will be set to on automatically.) Press the TEST switch ②. The display will return to normal.

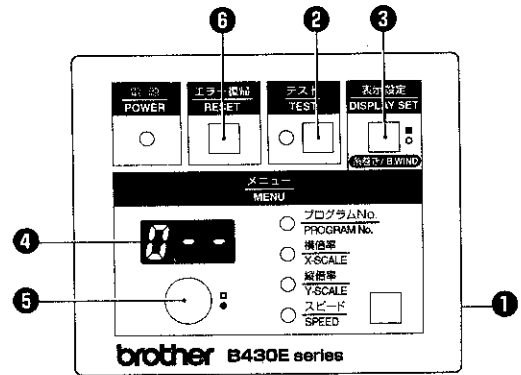

Switch	Motion when set to ON
memo-0	At the end of sewing, the feed plate will be returned to the sewing start point via mechanical home position.
memo-1	Button clamp will move to the sewing start point, and then will be lifted. *
memo-2	When using the handy switch to select a user program, the feed will move automatically to the next starting point at the same time as the program is switched. (Normally it moves to the starting point after sewing starts.)
memo-3	When sewing using user programs, the programs which have been set will be sewn in numerical order.
memo-4	Fixes the sewing speed at the minimum speed for the data.
memo-5,6	Changes the feed timing. (Refer to the "Feed timing settings" next page.)
memo-7	Backtacking starts after the first stitch. (Refer to next page.)
memo-8	Switches to single-stitch test mode.
memo-9	The sewing start point becomes the reference point for enlargements and reductions.
memo-A, b, c	—
memo-d	Enlargement and reduction of needle racking width for backtack stitches (with stitch widths of 1 mm or less) is carried out.
memo-E	Test feeding will be performed at the same speed as that for actual sewing. (This is used for checking feeding operation.)
memo-F	At the end of sewing, the button clamp will automatically open and close once. (This is used for running-in operation.)
memo-0.,1.,2.,	Used to change the timer for continuous sewing. (Refer to "Timer settings for continuous sewing" on the following page.)
memo-3.	—
memo-4.	The external solenoid wiper operates.

* The button clamp rises at the final stitch to enable the quick taking out of the workpieces.

13. CHANGING SPECIAL FUNCTIONS USING THE MEMORY SWITCHES

Backtacking starts after the first two stitches. Backtacking starts after the first stitch.

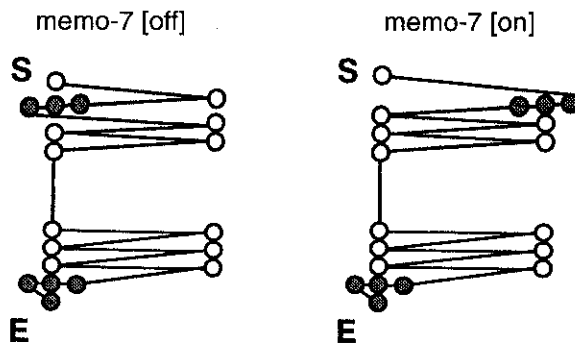

* When the thread is easily slipped off at the start of sewing, remain the setting of memo-7 to off.

Default settings for feed timing and upper shaft rotation angle [Revision]

Memory switch positions		Feed timing	Standard setting for each model	Example (*1)				Thread tightening
memo-5	memo-6			3 mm stitch length				
				2,000spm	1,600spm	1,300spm	1,000spm	
off	off	Slow	B430E Standard	135°	160°	180°	200°	Stronger ↑ ↓ Weaker
off	on	Medium slow		125°	125°	130°	130°	
on	off	Medium fast	B448E Standard	85°	90°	100°	110°	
on	on	Fast	B430E for thick materials	45°	55°	70°	80°	

*1) The angles given in the table are the angles of rotation of the upper shaft from the point where the needle down signal is input until the feed mechanism starts to operate, and are for reference only.

Actual angles will vary depending on factors such as the weight of the material being sewn and the stitch length.

*2) Do not set fast feed timing on the B448E. It will cause trouble such as needle breakage.

Timer settings for continuous sewing.

	0 s	0.1 s	0.2 s	0.3 s	0.4 s	0.6 s	0.8 s	1 s
memo-0.	off	on	off	on	off	on	off	on
memo-1.	off	off	on	on	off	off	on	on
memo-2.	off	off	off	off	on	on	on	on

14. LIST OF ERROR CODES

DANGER

-  • Wait at least 5 minutes after turning off the power switch and disconnecting the power cord from the wall outlet before opening the face plate of the control box. Touching areas where high voltages are present can result in severe injury.

If a malfunction should occur with the sewing machine, a buzzer will sound and an error code will appear in the display window. Press the RESET switch and then eliminate the cause of the error.

Error code	Cause	Remedy
E-2	The motor has stopped, the motor will not run, or there is a malfunction of the synchronizer.	Turn off the power, turn the machine pulley and check if the machine is locked. Check the synchronizer connections. Check whether connector P8, P9, P10 or P11 is disconnected.
E-3	Sewing data extends outside sewing area.	Press the RESET switch, and then set the enlargement ratio again.
E-4	The length of a stitch exceeds 10 mm, or there is some other abnormality in the sewing data.	Press the RESET switch, and then set the enlargement ratio again. If programming a new PROM, repeat the procedure from the beginning.
E-5	The needle bar does not stop when the needle is raised.	Turn the machine pulley to align the index mark with the needle up stop position. Adjust the needle up stop position to the standard position, or adjust the V-belt tension. Check whether connector [P2] of the synchronizer cord is disconnected.
E-60	Work clamps are not lowered.	Refer to "16. Troubleshooting".
E-61	Work clamps cannot be raised.	
E-62	Work clamps are not raised.	
E-63	No slit can be detected when the work clamps are lowered.	
E-7	The cooling fan does not operate.	Turn off the power, and then check if the cooling fan is blocked with scraps of thread.
E-8	Abnormality in motor PROM or malfunction of main P.C. board.	Turn off the power, and then contact an authorized service center.
E-9	Abnormal voltages occur.	Turn off the power and then, check the input voltage. (See page 41.)
E-A	The home position cannot be detected (malfunction of home position sensor), or malfunction of power supply P.C. board. You turned on the power switch immediately after turning it off.	Turn off the power, and then contact an authorized service center. Wait at least 5 seconds after turning off the power switch before turning it on.
E-b	You tried to change the program number when DIP switch A-8 was set to ON.	Press the RESET switch. Set DIP switch A-8 to OFF before trying to change the program number.

Error code	Cause	Remedy
E-d	The heat sink of the main P.C. board is abnormally hot.	Turn off the power, and then clean the air inlet port of the control box.
E-E	Malfunction of EEPROM (malfunction of main P.C. board).	Turn off the power, and then wait a while before turning it back on. If the error keeps reappearing, contact an authorized service center.
E-F	The power supply relay does not operate (malfunction of power supply P.C. board).	Turn off the power, and then contact an authorized service center.

15. ADJUSTMENT GUIDE REFER TO THIS GUIDE WHEN DIFFERENT BUTTON ARE USED

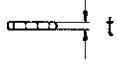
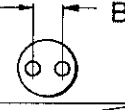
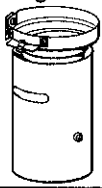
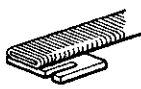
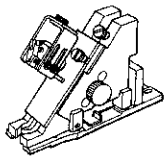
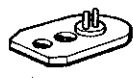
	When button diameter (D) changes 	When button thickness (t) changes 	When button hole gap (B) changes 	Page
Vibrating Bowl 	Adjust button selector			26
	Adjust button guide			26
		Adjust height control plate		26
	Adjust button adjustment dial			26
Shooter Coil 	Replace the shooter coil			17
Button Slide Base 	Adjust slide base width			28
	Adjust the stopper			28
	Replace the button top cover			28
		Replace the spacer (S)		29
Button Catch Plate 			Replace the button carrier	29
Feeder Installation Position			Adjust right/left needle and button carrier pin positions	30
Machine Head	Adjust button clamp width			28
			Adjust needle location	31

16. TROUBLESHOOTING

Problem	Cause	Check	Remedy	Page
Button clamp does not rise.	Button clamp lifter amount is too great.	Distance between button clamp and top of needle plate	Adjust the height of the button clamp to within 13 mm.	38
	Presser is contacting thread wiper.	Thread wiper standby position	Adjust the position of the thread wiper.	40
Button clamp does not drop.	Presser lifter link is not moving back.	Link return spring is unhooked.	Hook the link return spring properly.	
Button clamp lift amount is incorrect.	Incorrect position of button clamp holder hook assembly	Distance between button clamp and top of needle plate	Adjust the button clamp lift amount.	38
Thread wiper does not operate correctly.	The thread wiper is obstructing the needle.	Clearance between thread wiper and needle tip	Adjust the height of the thread wiper.	40
	Thread wiper position is incorrect.	Thread wiper position	Adjust the operating distance of the thread wiper.	40
Lower thread winds to one side.	Bobbin winder thread tension stud height is incorrect.	Bobbin winder thread tension stud height	Adjust the height of the thread tension stud.	23
Lower thread winding amount is incorrect.	Bobbin presser position is incorrect.	Thread winding amount	Adjust the position of the bobbin presser.	23
Threads comes unthreaded.	Stitches being skipped at the sewing start.	Refer to "Skipped stitches occur".	Refer to "Skipped stitches occur".	
	Uneven upper thread length.	Upper thread length	Adjust the sub-tension.	24

Problem	Cause	Check	Remedy	Page
Upper thread breaks.	Upper thread tension is too strong.	Upper thread tension	Adjust the upper thread tension.	20
	Needle is installed incorrectly.	Needle direction	Install the needle so that the groove is facing forward.	22
	Thread is too thick for the needle.	Thread and needle	Use the correct thread for the needle.	22
	Thread takeup spring tension and height are incorrect.	Thread takeup spring tension and height	Adjust the tension and height of the thread takeup spring.	25
	Damaged or burred rotary hook, needle hole plate or needle	Damage or burring	File smooth or replace the affected part.	/
Lower thread breaks.	Lower thread tension is too strong.	Lower thread tension	Adjust the lower thread tension.	24
	Corners of needle hole plate or bobbin case are damaged.	Damage	File smooth or replace the affected part.	/
Skipped stitches occur.	Clearance between needle and rotary hook tip is too great.	Needle clearance	Adjust the needle clearance.	36
	Incorrect needle and rotary hook timing	Needle bar lift amount	Adjust the needle bar lift amount.	35
	Driver is contacting needle more than is necessary.	Clearance between driver and needle	Adjust the driver needle guard.	36
	Needle is bent.	Bent needle	Replace the needle.	/
	Needle is installed incorrectly.	Needle direction	Install the needle so that the groove is facing forward.	22
Needle breaks.	Needle is striking the button.	Needle down setting	Adjust so that the needle drops down into the hole of the button.	31,38
	Needle is touching the rotary hook.	Needle clearance	Adjust the needle clearance.	36
		Needle bar lift amount.	Adjust the needle bar lift amount.	35
	Needle is bent.	Bent needle	Replace the needle.	/
	Wayward stitches	Needle and feed timing	Adjust the needle down detection position.	40
	Needle is too thin.	Needle and thread	Use the correct needle for the material.	/

16. TROUBLESHOOTING

Problem	Cause	Check	Remedy	Page
Upper thread is not trimmed.	Fixed knife is blunt.	Fixed knife blade	Sharpen or replace the fixed knife.	/
	Movable knife does not pick up the thread.	Shuttle race thread guide position	Adjust the position of the shuttle race thread guide.	36
		Needle bar lift amount	Adjust the needle bar lift amount.	35
	The movable knife does not pick up the thread because of skipped stitches at the sewing end.	Skipped stitches at sewing end	Refer to "Skipped stitches occur".	/
	Movable knife position is incorrect.	Movable knife position	Adjust the position of the movable knife.	37
Sub-tension is too weak.	Sub-tension	Turn the sub-tension nut to adjust the tension.	24	
Thread jamming	Thread takeup spring tension and height are incorrect.	Thread takeup spring tension and height	Adjust the tension and height of the thread takeup spring.	25
	Incorrect needle and rotary hook timing	Needle bar lift amount	Adjust the needle bar lift amount.	35
	Shuttle race thread guide is not separating the threads.	Shuttle race thread guide position	Adjust the position of the shuttle race thread guide.	36
Poor seam finish on reverse side of material.	Shuttle race thread guide is not separating the threads.	Shuttle race thread guide position	Adjust the position of the shuttle race thread tension.	36
	Upper thread is not properly tight.	Upper thread tension	Adjust the upper thread tension.	24
	Uneven upper thread length	Upper thread length	Adjust the sub-tension.	24
Incorrect thread tightness	Upper thread tension is too weak.	Upper thread tension	Adjust the upper thread tension.	24
	Lower thread tension is too weak.	Lower thread tension	Adjust the lower thread tension.	24
	Thread takeup spring tension and height are incorrect.	Thread takeup spring tension and height	Adjust the tension and height of the thread takeup spring.	25
Button breaks.	Needle is striking the button.	Needle down setting	Adjust so that the needle drops into the hole of the button.	31,38

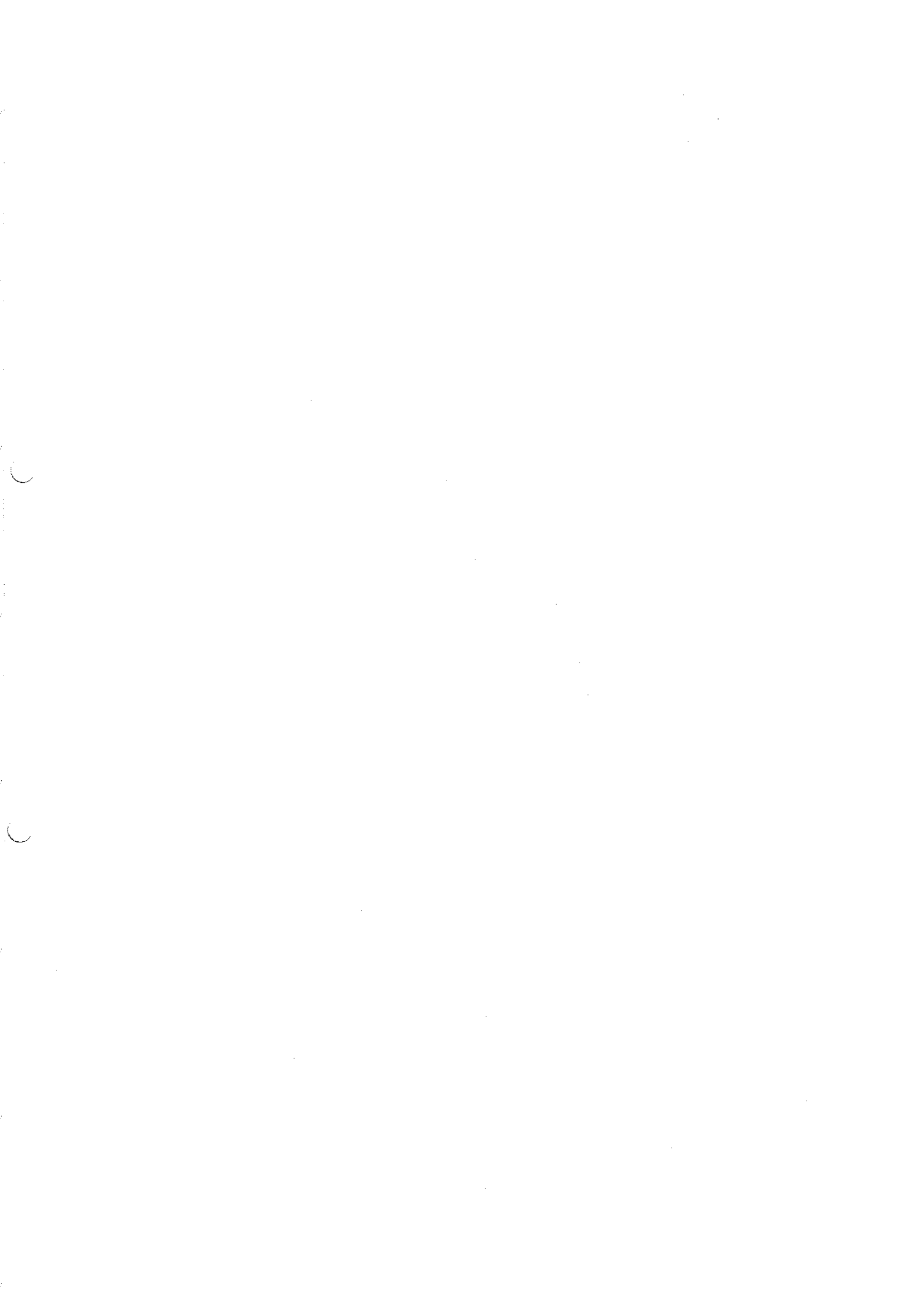

brother.

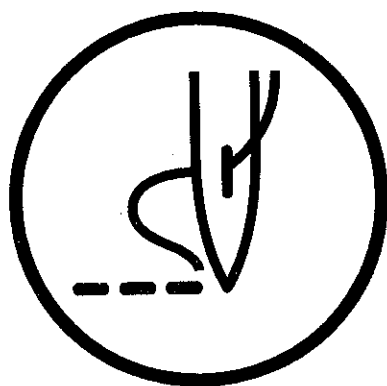

INSTRUCTION MANUAL

BROTHER INDUSTRIES,LTD. NAGOYA,JAPAN

Printed in Japan

118-Z48 / 151-916
S93916-002
1997.09 H ①