

LK3-B430E Mark II

SERVICE MANUAL



Please read this manual before making any adjustments.

ELECTRONIC LOCKSTITCH BAR TACKER

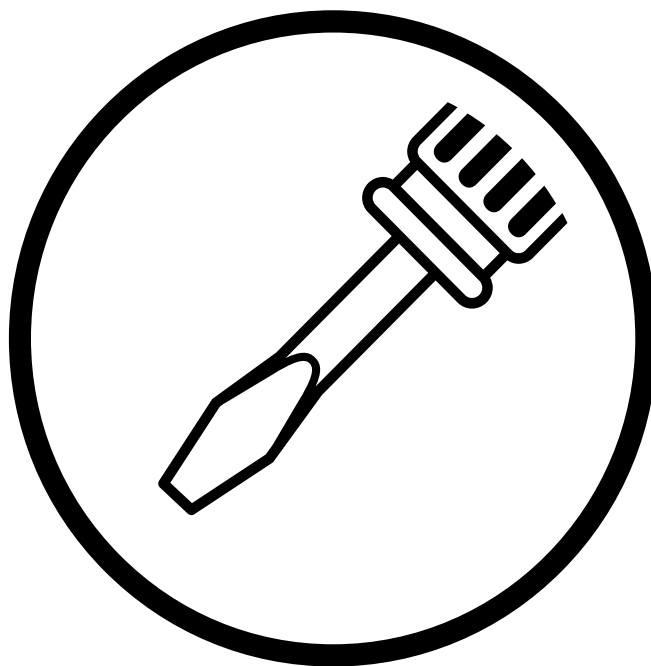

brother[®]

This service manual is intended for B430E Mark II; be sure to read the B430E Mark II instruction manual before this manual. Carefully read the "SAFETY INSTRUCTIONS" below and the whole of this manual to understand this product before you start maintenance.

As a result of research and improvements regarding this product, some details of this manual may not be the same as those for the product you purchased.

If you have any questions regarding this product, please contact a Brother dealer.



SAFETY INSTRUCTIONS

1. Safety indications and their meanings

This service manual and the indications and symbols that are used on the machine itself are provided in order to ensure safe operation of this machine and to prevent accidents and injury to yourself or other people.

The meanings of these indications and symbols are given below.

Indications

 DANGER	The instructions which follow this term indicate situations where failure to follow the instructions will almost certainly result in death or severe injury.
 CAUTION	The instructions which follow this term indicate situations where failure to follow the instructions could cause injury when using the machine or physical damage to equipment and surroundings.

Symbols



..... This symbol () indicates something that you should be careful of. The picture inside the triangle indicates the nature of the caution that must be taken.
(For example, the symbol at left means "beware of injury".)



..... This symbol () indicates something that you must not do.



..... This symbol () indicates something that you must do. The picture inside the circle indicates the nature of the thing that must be done.
(For example, the symbol at left means "you must make the ground connection".)

2. Notes on safety

DANGER



Wait at least 5 minutes after turning off the power switch and disconnecting the power cord from the wall outlet before opening the face plate of the control box. Touching areas where high voltages are present can result in severe injury.

CAUTION

Environmental requirements



Use the sewing machine in an area which is free from sources of strong electrical noise such as high-frequency welders. Sources of strong electrical noise may cause problems with correct operation.



Any fluctuations in the power supply voltage should be within $\pm 10\%$ of the rated voltage for the machine. Voltage fluctuations which are greater than this may cause problems with correct operation.



The power supply capacity should be greater than the requirements for the sewing machine's electrical consumption. Insufficient power supply capacity may cause problems with correct operation.



The ambient temperature should be within the range of 5°C to 35°C during use. Temperatures which are lower or higher than this may cause problems with correct operation.



The relative humidity should be within the range of 45% to 85% during use, and no dew formation should occur in any devices. Excessively dry or humid environments and dew formation may cause problems with correct operation.



Avoid exposure to direct sunlight during use. Exposure to direct sunlight may cause problems with correct operation.



In the event of an electrical storm, turn off the power and disconnect the power cord from the wall outlet. Lightning may cause problems with correct operation.

Installation



Machine installation should only be carried out by a qualified technician.



Contact your Brother dealer or a qualified electrician for any electrical work that may need to be done.



The sewing machine weighs more than 47 kg. The installation should be carried out by two or more people.



Do not connect the power cord until installation is complete, otherwise the machine may operate if the foot switch is pressed by mistake, which could result in injury.



Hold the machine head with both hands when tilting it back or returning it to its original position.

Furthermore, after tilting back the machine head, do not push the face plate side or the pulley side from above, as this could cause the machine head to topple over, which may result in personal injury or damage to the machine.



Be sure to connect the ground. If the ground connection is not secure, you run a high risk of receiving a serious electric shock, and problems with correct operation may also occur.



All cords should be secured at least 25 mm away from any moving parts. Furthermore, do not excessively bend the cords or secure them too firmly with staples, otherwise there is the danger that fire or electric shocks could occur.



Install the belt covers to the machine head and motor.



If using a work table which has casters, the casters should be secured in such a way so that they cannot move.



Be sure to wear protective goggles and gloves when handling the lubricating oil and grease, so that they do not get into your eyes or onto your skin, otherwise inflammation can result.











Furthermore, do not drink the oil or eat the grease under any circumstances, as they can cause vomiting and diarrhoea.

Keep the oil out of the reach of children.





CAUTION









Sewing

-  This sewing machine should only be used by operators who have received the necessary training in safe use beforehand.
-  The sewing machine should not be used for any applications other than sewing.
-  Be sure to wear protective goggles when using the machine.
If goggles are not worn, there is the danger that if a needle breaks, parts of the broken needle may enter your eyes and injury may result.
-  Wait until the needle stops in the needle up position before turning off the power.
If this is not done, the wiper may strike the needle, which might cause the needle to break.
-  Turn off the power switch at the following times, otherwise the machine may operate if the foot switch is pressed by mistake, which could result in injury.
 - When threading the needle
 - When replacing the needle and bobbin
 - When not using the machine and when leaving the machine unattended
-  If using a work table which has casters, the casters should be secured in such a way so that they cannot move.
-  Attach all safety devices before using the sewing machine. If the machine is used without these devices attached, injury may result.
-  Do not touch any of the moving parts or press any objects against the machine while sewing, as this may result in personal injury or damage to the machine.
-  If an error occurs in machine, or if abnormal noises or smells are noticed, immediately turn off the power switch. Then contact your nearest Brother dealer or a qualified technician.
-  If the machine develops a problem, contact your nearest Brother dealer or a qualified technician.

Cleaning

-  Wait until the needle stops in the needle up position before turning off the power.
If this is not done, the wiper may strike the needle, which might cause the needle to break.
-  Turn off the power switch before carrying out cleaning, otherwise the machine may operate if the foot switch is pressed by mistake, which could result in injury.
-  Be sure to wear protective goggles and gloves when handling the lubricating oil and grease, so that they do not get into your eyes or onto your skin, otherwise inflammation can result.
Furthermore, do not drink the oil or eat the grease under any circumstances, as they can cause vomiting and diarrhoea.
Keep the oil out of the reach of children.

Maintenance and inspection

-  Maintenance and inspection of the sewing machine should only be carried out by a qualified technician.
-  Ask your Brother dealer or a qualified electrician to carry out any maintenance and inspection of the electrical system.
-  Wait until the needle stops in the needle up position before turning off the power.
If this is not done, the wiper may strike the needle, which might cause the needle to break.
-  Turn off the power switch and disconnect the power cord from the wall outlet at the following times, otherwise the machine may operate if the foot switch is pressed by mistake, which could result in injury.
 - When carrying out inspection, adjustment and maintenance
 - When replacing consumable parts such as the rotary hook
-  If the power switch needs to be left on when carrying out some adjustment, be extremely careful to observe all safety precautions.
-  Hold the machine head with both hands when tilting it back or returning it to its original position.
Furthermore, after tilting back the machine head, do not push the face plate side or the pulley side from above, as this could cause the machine head to topple over, which may result in personal injury or damage to the machine.
-  Use only the proper replacement parts as specified by Brother.
-  If any safety devices have been removed, be absolutely sure to re-install them to their original positions and check that they operate correctly before using the machine.
-  Any problems in machine operation which result from unauthorized modifications to the machine will not be covered by the warranty.

3. Warning labels

The following warning labels appear on the sewing machine. Please follow the instructions on the labels at all times when using the machine. If the labels have been removed or are difficult to read, please contact your nearest Brother dealer.

1



2



Safety devices

- Eye guard
- Finger guard
- Thread take-up cover
- Thread take-up solenoid cover
- Belt cover
- Motor cover, etc.

3



Be sure to connect the ground. If the ground connection is not secure, you run a high risk of receiving a serious electric shock, and problems with correct operation may also occur.

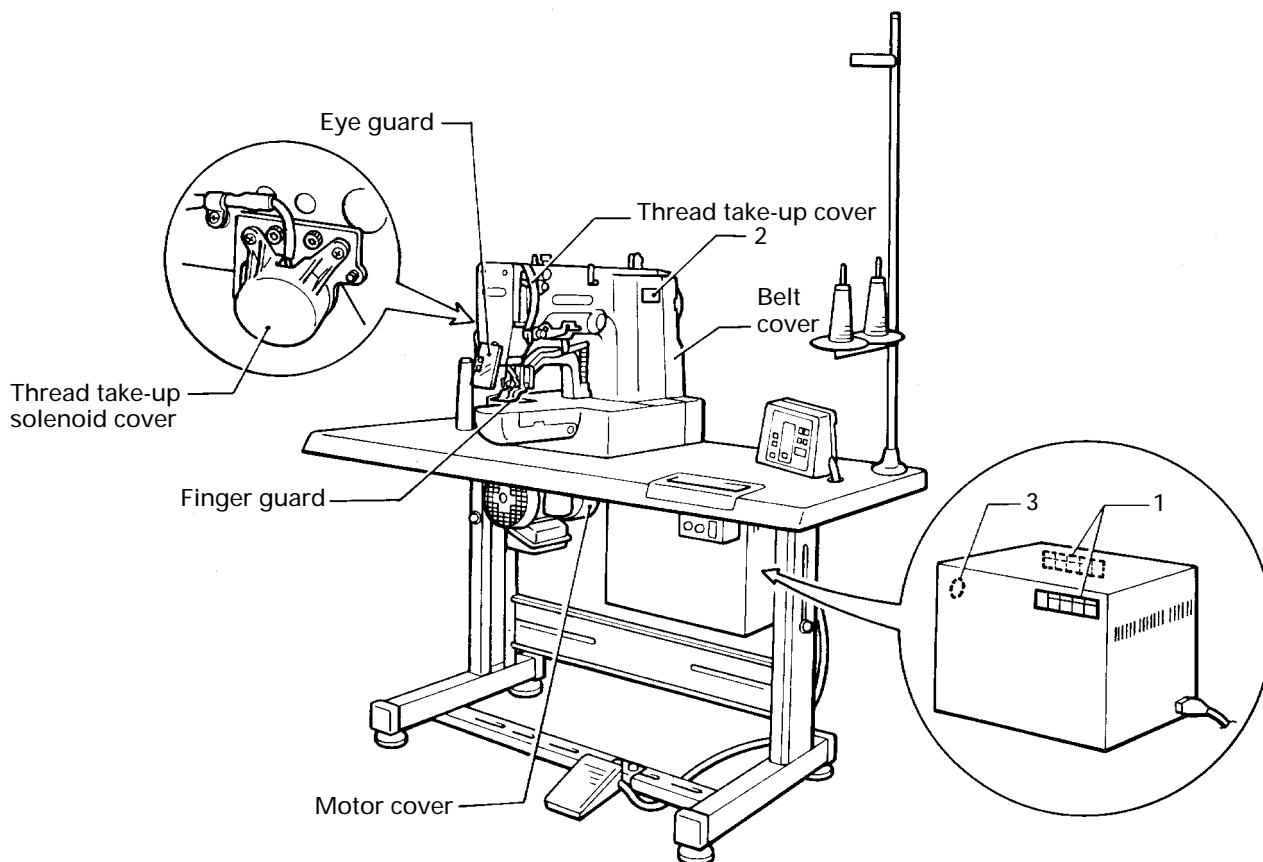











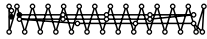
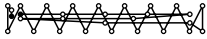

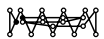

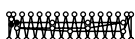
Contents



1. PROGRAM LIST	1	5-7. Upper shaft mechanism	33
2. STANDARD THREAD TENSION	4	5-8. Needle bar mechanism	34
3. MECHANICAL DESCRIPTIONS	5	5-9. Lower shaft mechanism	35
3-1. Needle bar, thread take-up, lower shaft and shuttle race mechanisms	5	5-10. Thread trimmer mechanism (2)	36
3-2. Work clamp lifter mechanism	6	5-11. Thread wiper mechanism (2)	37
3-3. Work clamp lifter and thread wiper mechanisms	6	5-12. Shuttle race mechanism	38
3-4. Feed mechanism	7	5-13. Presser arm mechanism	39
3-5. Thread trimmer mechanism	8	5-14. Covers	40
3-6. Thread nipper mechanism	9	6. ADJUSTMENT	41
3-6-1. Manual operation	9	6-1. Adjusting the needle bar height	41
3-6-2. In thread trimming	9	6-2. Adjusting the needle bar lift stroke	41
3-7. Thread take-up mechanism	10	6-3. Adjusting the driver needle guard	42
4. DISASSEMBLY	11	6-4. Adjusting the needle clearance	42
4-1. Covers	11	6-5. Adjusting the shuttle race thread guide	42
4-2. Presser arm mechanism	12	6-6. Adjusting the work clamp lift amount	43
4-3. Shuttle hook mechanism	12	6-7. Adjusting the thread wiper	43
4-4. Needle bar mechanism	13	6-8. Adjusting the thread take-up amount	44
4-5. Upper shaft mechanism	14	6-9. Adjusting the movable knife	44
4-6. Lower shaft mechanism	15	6-9-1. Replacing the movable and fixed knives ...	45
4-7. Feed mechanism	16	6-9-2. Adjusting the engagement of the movable knife and fixed knife	45
4-8. Presser mechanism	19	6-10. Adjusting the driving lever stopper position	46
4-9. Thread wiper mechanism	20	6-11. Adjusting the thread trimmer driving lever position	46
4-10. Thread nipper mechanism	21	6-12. Adjusting the thread trimming solenoid position	47
4-11. Thread take-up mechanism	22	6-13. Adjusting the backlash	47
4-12. Thread trimmer mechanism	23	6-14. Adjusting the positions of the presser solenoid ..	48
5. ASSEMBLY	24	6-15. Adjusting the sensor perceive plate position ..	48
5-1. Thread trimmer mechanism (1)	24	6-16. Adjusting the home position	49
5-2. Thread nipper mechanism	25	6-17. Adjusting the needle up stop position	49
5-3. Thread wiper mechanism (1)	26	6-18. Adjusting the V belt tension	50
5-4. Thread take-up mechanism	27	7. GAUGE PARTS LIST ACCORDING TO SUBCLASSES	51
5-5. Presser mechanism	28	8. OPTIONAL PARTS	56
5-6. Feed mechanism	30		

9. TROUBLESHOOTING	57
10. ELECTRIC MECHANISM	61
10-1. Precautions at the time of adjustment	61
10-2. Components inside the control box and the operation panel	61
10-3. Fuse explanation	62
10-4. Connectors	63
10-5. Explanation of the DIP switches	68
10-5-1. Panel DIP switch functions	68
10-5-2. Setting the presser mode	68
10-5-3. DIP switches inside the control box	69
10-6. Explanation of the memory switches	70
10-7. Checking the input sensor and DIP switch input	72
10-8. Checking the input voltage	73
10-9. Clearing all memory settings	73
10-10. Confirming software version	74
10-11. Table of error codes	75
10-12. Troubleshooting flowchart	77
10-12-1. Troubleshooting flowchart	77
10-12-2. Problem solution and measures	80
10-13. Control circuit block diagram	91

1. PROGRAM LIST



For each specification, sewing patterns are limited as shown in the table below. (Any program is available as long as the sewing pattern is within the work clamp and feed plate in size.)

Specifica-tion	Use	Program No.	Sewing pattern	No. of stitches	Standard bar tacking length	Standard bar tacking width
-1	For ordinary materials	1		42	16mm	2mm
		4		30	16mm	2mm
5			29	10mm	2mm	
8			21	7mm	2mm	
-5		13		35	10mm	2mm
		15		42	10mm	2mm
		20		28	7mm	2mm
		21		35	7mm	2mm
	-2	For denim	2		42	20mm
3				35	20mm	3mm
6				30	16mm	3mm
14				35	16mm	3mm
16				43	16mm	3mm
17				42	24mm	3mm
18				56	24mm	3mm
19				64	24mm	3mm

Specifica- tion	Use	Program No.	Sewing pattern	No. of stitches	Standard bar tacking length	Standard bar tacking width
-7	For knitted materials	7		28	8mm	2mm
		9		21	7mm	2mm
		22		14	7mm	2mm

- * To prevent thread breakage due to heat, set the sewing speed to a maximum of 2,500 rpm for sewing knitted materials.
- * The difference between -1 and -5 specifications for ordinary material is that the standard presser foot and feed plate are different.
- * Length when the sewing size is 100%.

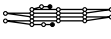
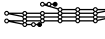
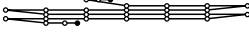

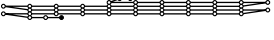
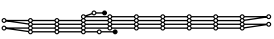

<Straight bar tacking>

Program No.	Sewing pattern	No. of stitches	Standard bar tacking length	Standard bar tacking width
10		21	10mm	0.3mm
11		28	10mm	0.3mm
12		28	20mm	0.3mm
23		35	25mm	0.3mm
24		42	25mm	0.3mm
25		45	25mm	0.3mm

- * Use the presser foot and feed plate for straight bar tacking when using the above programs.

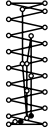
1. PROGRAM LIST

<Vertical bar tacking & vertical straight bar tacking>

	Program No.	Sewing pattern	No. of stitches	Standard bar tacking length	Standard bar tacking width
Vertical bar tacking	26		28	3mm	10mm
	27		35	3mm	10mm
vertical straight bar tacking	28		19	0.3mm	10mm
	29		21	0.3mm	10mm
	30		28	0.3mm	10mm

* Use the presser foot and feed plate for straight bar tacking when using the above programs.

2. STANDARD THREAD TENSION

Application	Ordinary materials (-1, -5)		Denim (-2)		Knitted materials (-7)
	Standard hook	Large hook	Standard hook	Large hook	Standard hook
Needle thread	#50 or equivalent	←	#30 or equivalent	←	#60 or equivalent
Lower thread	#60 or equivalent	←	#50 or equivalent	←	#80 or equivalent
Needle thread tension (N)	0.6 - 0.9	1.0 - 1.3	1.2 - 1.6	1.4 - 1.8	0.8 - 1.0
Lower thread tension (N)	0.2 - 0.3	←	0.2 - 0.3	←	0.2 - 0.3
Spring height (mm)	6 - 8	←	6 - 8	←	6 - 8
Spring tension (N)	0.15 - 0.35	←	0.4 - 0.6	←	0.2 - 0.4
Pretension (N)	0.1 - 0.3	←	0.3 - 0.5	←	0.1 - 0.3
Needle	DP×5#14	←	DP×17NY#19	←	DP×5#9

■ Measuring tension

Needle thread tension

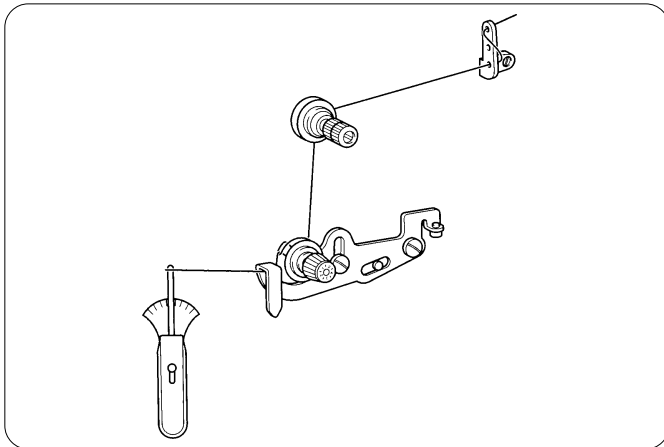

Lower thread tension

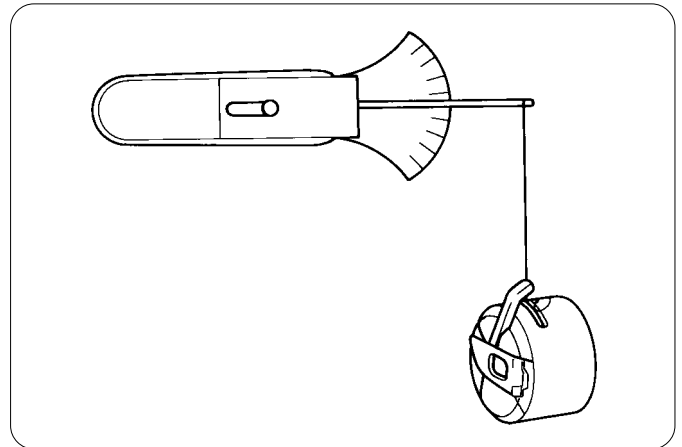

Spring height

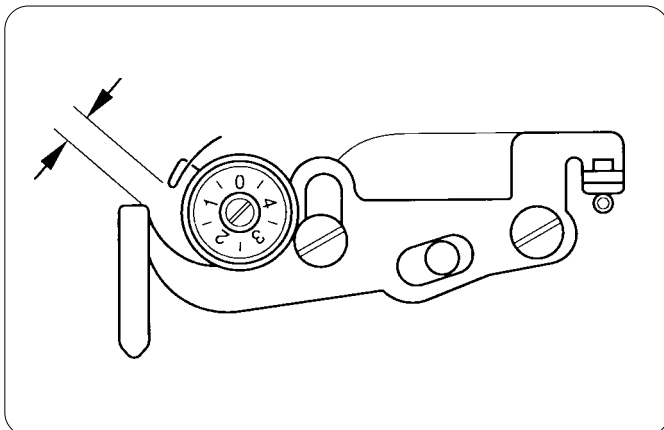

Spring tension

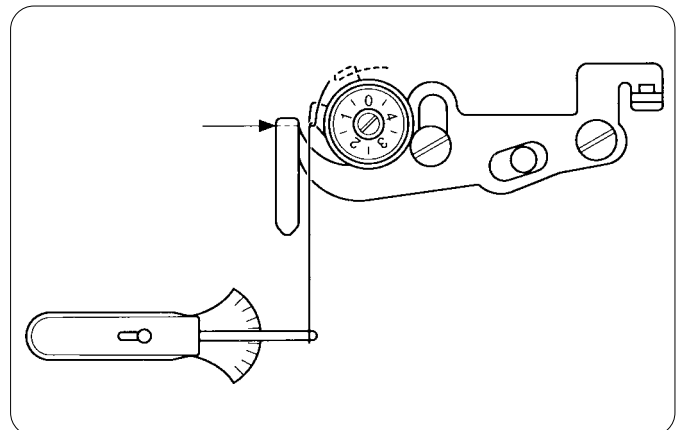

Measure the spring tension when the spring end is lowered to the thread hook of the thread take-up lever.

* When the spring height (stroke) is great or the spring tension is insufficient, it may cause the thread end length to vary after thread trimming.

3. MECHANICAL DESCRIPTIONS

3-1. Needle bar, thread take-up, lower shaft and shuttle race mechanisms

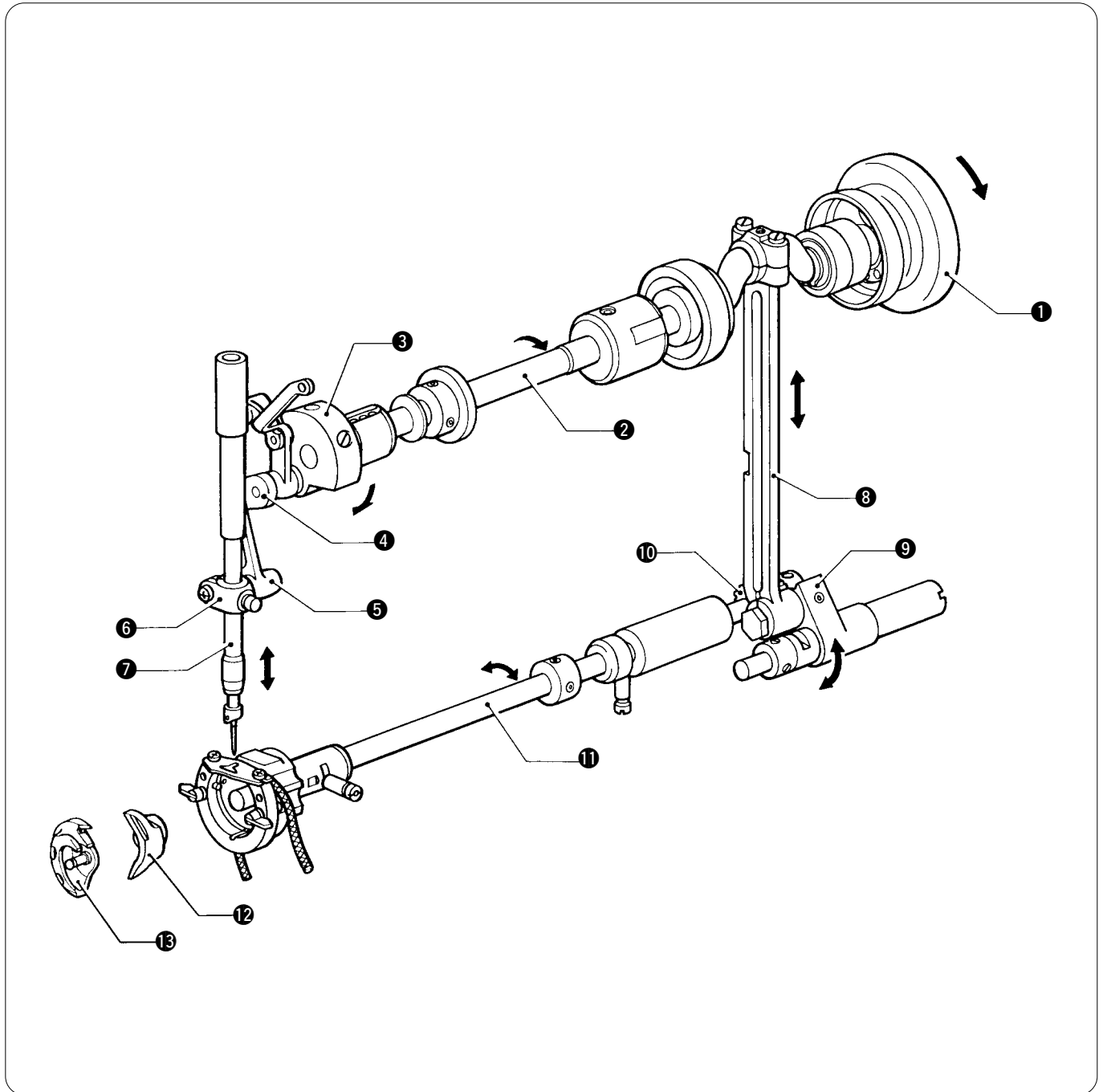

1. When the pulley **1** rotates in the direction of the arrow, the motion is transmitted to the thread take-up crank **3** through the upper shaft **2**.
2. The needle bar crank **4** attached to the crank **3** moves the thread take-up lever **5**.
3. The needle bar crank **6** moves the needle bar **7** up and down via the thread take-up lever **5**.
4. When the pulley **1** rotates in the direction of the arrow, the eccentric portion of the upper shaft **2** causes the crank rod **8** to move up and down.
5. The crank rod **8** moves the rock gear **9** back and forth.
6. The motion of the rock gear **9** causes the lower shaft gear **10** to oscillate. Resultantly, the driver **12** and the shuttle hook **13** in the shuttle hook mechanism oscillate.

3-2. Work clamp lifter mechanism

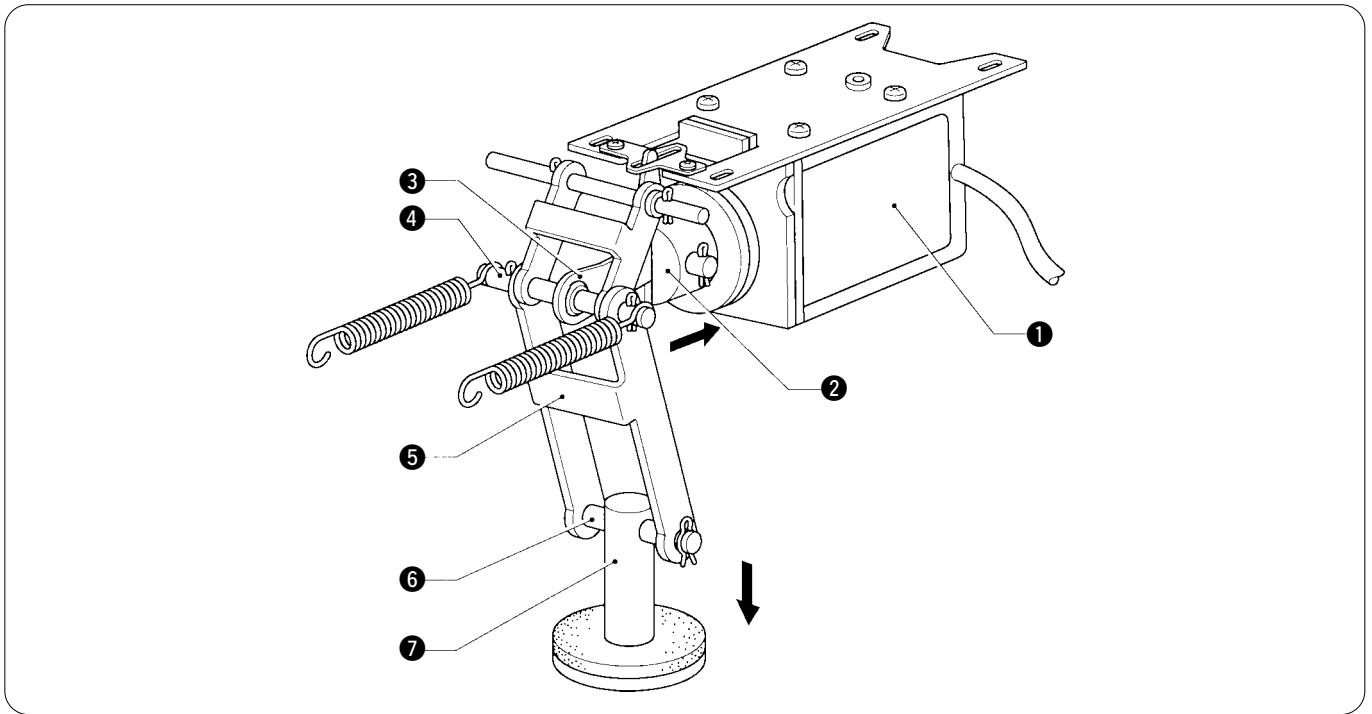

1. When the presser signal is on, the presser solenoid ① operates.
2. The plunger ② moves in the direction of the arrow, and consequently link (C) assy ③, link shaft B ④, and link B ⑤ move.
3. Link B ⑤ presses the presser plate ⑦ down via link shaft C ⑥.

3-3. Work clamp lifter and thread wiper mechanisms

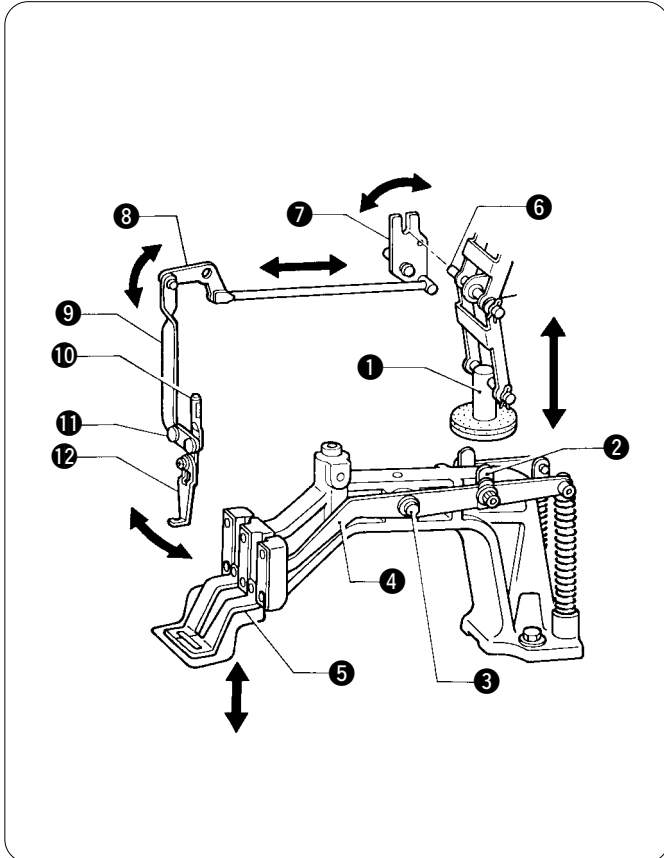

1. When the presser plate ① lowers, the presser arm lever plate ② is pressed down, presser arm levers R and L ④ pivot on the presser arm lever shaft ③, and work clamps R and L ⑤ rise.
2. When the presser plate ① lowers, the motion is transmitted to the thread wiper driving lever ⑦, the thread wiper rod assembly ⑧, and the thread wiper link ⑨ via link shaft B ⑥, and the thread wiper arm ⑪ and the thread wiper ⑫ operate via the thread wiper arm support ⑩.
3. When the presser solenoid is turned off, the presser plate ① rises, and work clamps R and L ⑤ lower. Simultaneously, the thread wiper ⑫ operates in the opposite direction.

3. MECHANICAL DESCRIPTIONS

3-4. Feed mechanism

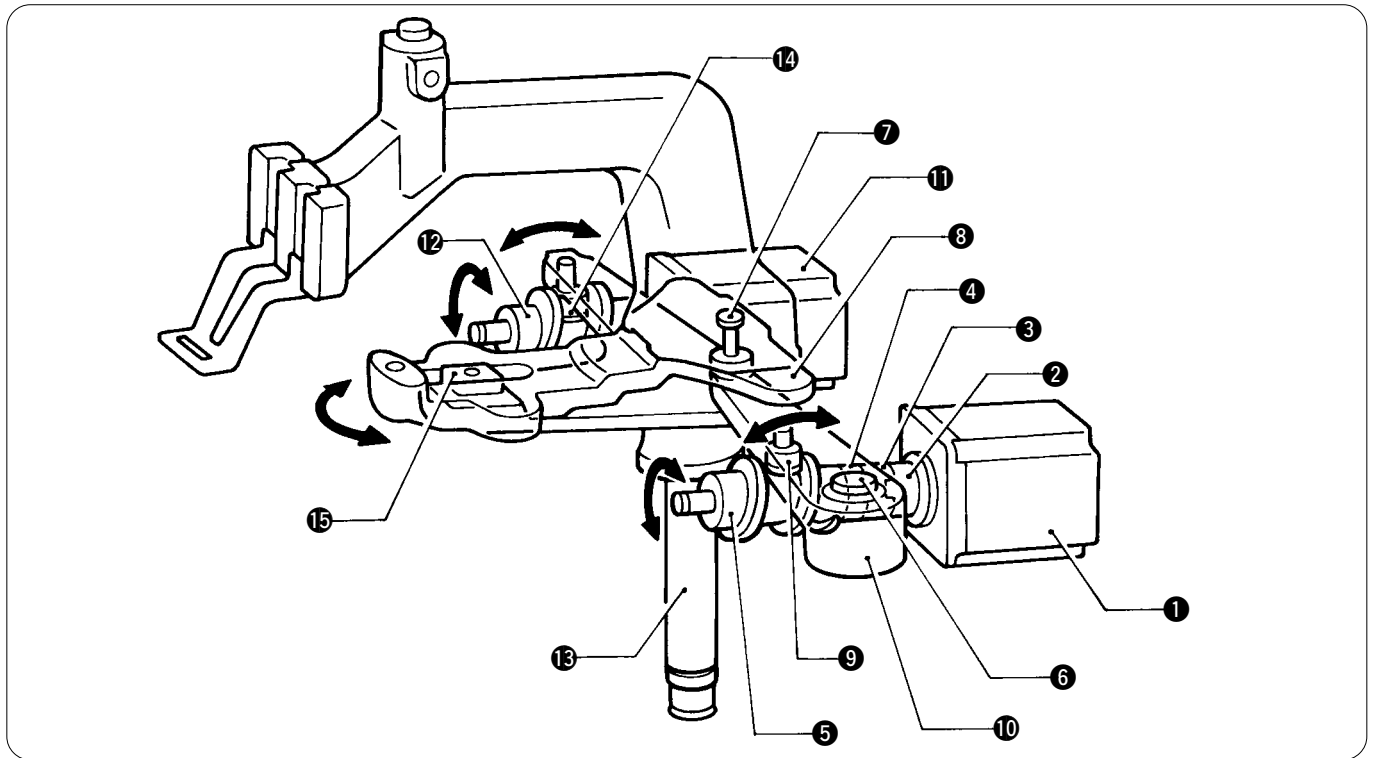

(Y direction)

1. When the Y-pulse motor **1** operates, coupling hub 6.35 **2**, the coupling spacer **3**, and coupling hub 8 **4** transmit the motion to feed cam Y **5**.
2. Feed cam Y **5** is connected to the Y-feed lever **10** pivoting on the tack width lever shaft **6**, which is connected to the feed bracket **8** with the tack width lever **7**, via the feed cam roller **9**.
3. The motion of the Y feed lever **10** is transmitted to the feed bracket **8** via the tack width lever shaft **6**.

(X direction)

1. The motion of the X-pulse motor **11** is transmitted to feed cam X **12** with the same couplings as for Y direction.
2. One end of the X feed lever **13** is positioned on feed cam X **12** along with the feed cam roller **14**, and the other is attached to the feed bracket **8** along with the slide block **15**. When feed cam X **12** moves, the feed bracket **8** oscillates, pivoting on the tack width lever shaft **7**.

Sewing patterns are created through combinations of X and Y movements shown above.

3-5. Thread trimmer mechanism

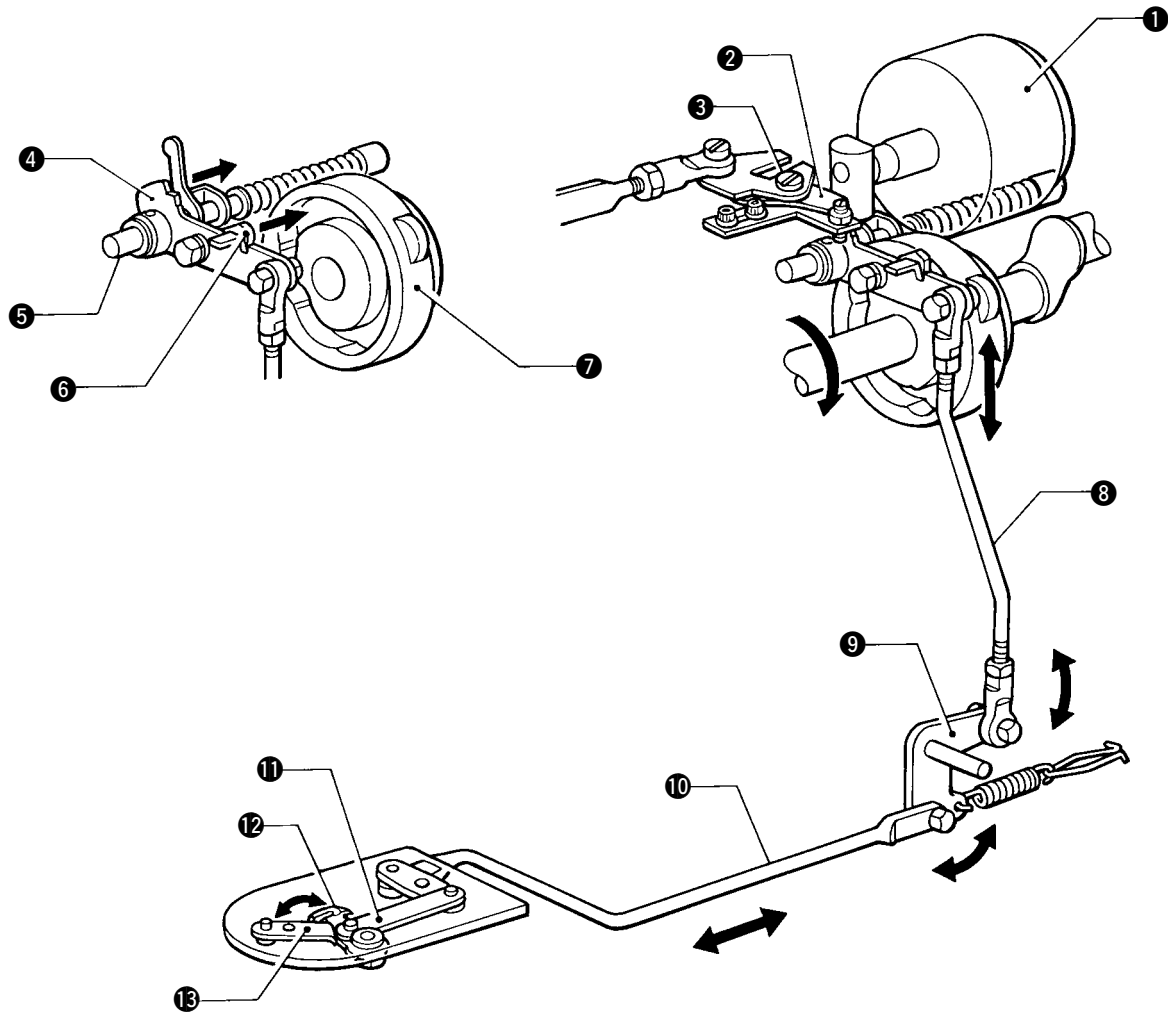

1. When the thread trimming signal is on, the thread trimming solenoid **1** pushes the pushing lever driving lever **2**.
2. The pushing lever driving lever **2** which pivots on the shoulder screw **3**, pushes the thread trimmer driving lever **4** in the direction of the arrow, and slides on the driving lever shaft **5**.
3. The roller **6** attached to the thread trimmer driving lever **4** is inserted into the groove of the thread trimmer cam **7**, and the thread trimmer rod **8** operates.
4. The thread trimmer rod **8** moves the connecting rod lever **10** via the thread trimmer lever **9**.
5. The thread trimmer connecting rod **11** attached to the connecting rod lever **10** operates, and the movable knife **12** slides on the fixed knife **13** to trim the thread.

3. MECHANICAL DESCRIPTIONS

3-6. Thread nipper mechanism

3-6-1. Manual operation

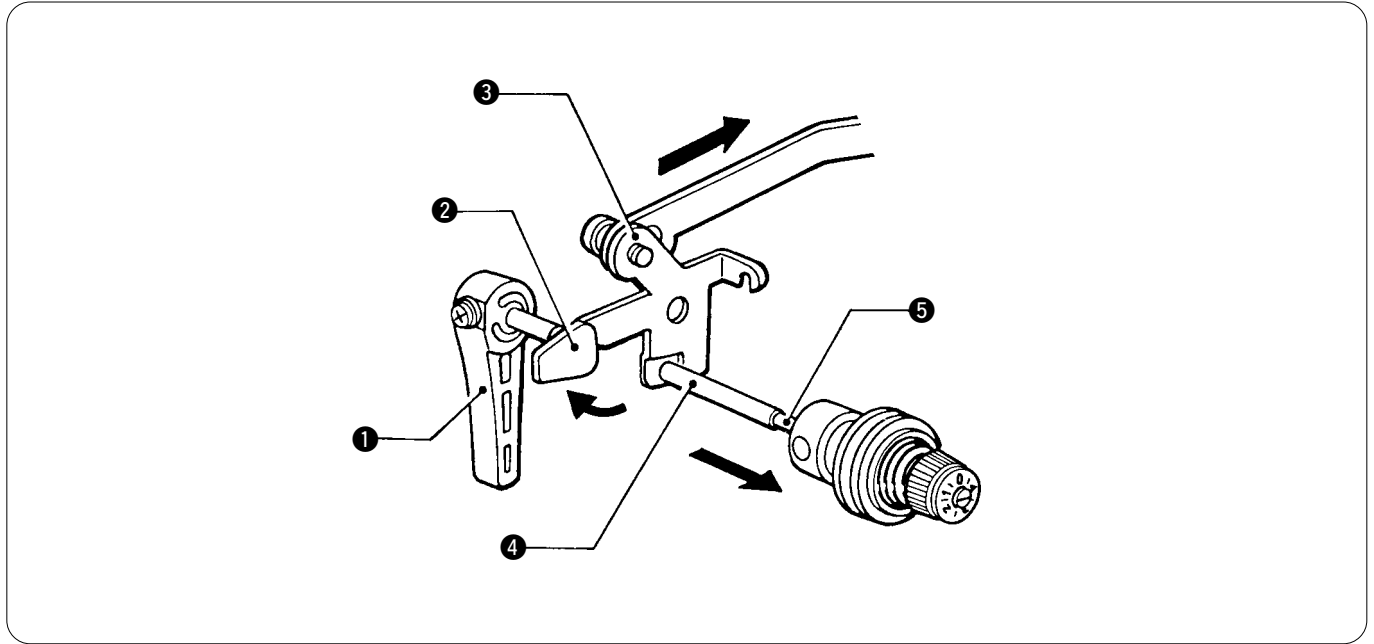

1. When the presser bar lifter lever ① is turned in the direction of the arrow, the presser bar lifter crank ② makes contact with the tension release lever ③, pushing the tension release bar ④.
2. The end of the tension release bar ④ pushes the pin ⑤.

3-6-2. In thread trimming

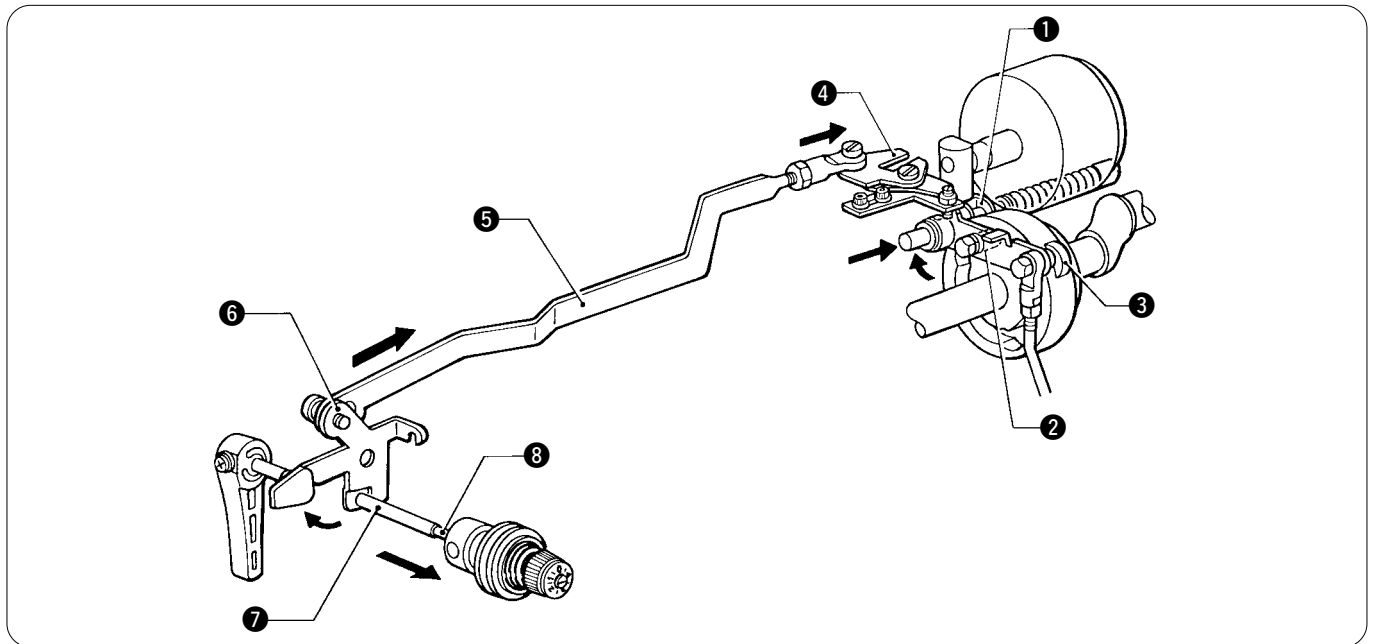

1. When the thread trimming signal is received, the thread trimmer solenoid operates to push the tension release driving lever ① in the direction of the arrow, and the roller ② which is attached to the tension release driving lever ① is positioned on the periphery of the thread trimmer cam ③.
2. The tension release cam of the thread trimmer cam ③ moves the tension release driving lever ① in the direction of the arrow.
3. Tension release lever (U) ④, which is engaged with the tension release driving lever ①, moves in the direction of the arrow.
4. The tension release lever (U) ④ moves the tension release lever ⑥ via the tension release rod assy ⑤.
5. The tension release lever ⑥ pushes the tension release bar ⑦.
6. The end of the tension release bar ⑦ pushes the pin ⑧.

3-7. Thread take-up mechanism

* Denim specification is optional.

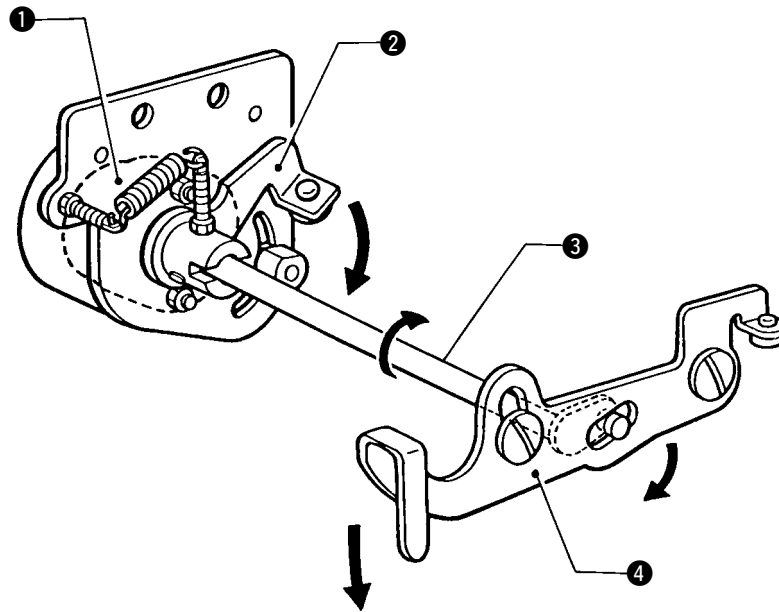

1. When the thread trimming signal is received, the thread trimmer solenoid ① operates to move the solenoid joint ② in the direction of the arrow.
2. The crank shaft ③ engaged with the solenoid joint ② turns in the direction of the arrow.
3. The thread take-up lever ④ engaged with the crank shaft ③ operates in the direction of the arrow.

4. DISASSEMBLY

⚠ CAUTION



Turn off the power switch before disassembly, otherwise the machine may operate if the foot switch is depressed by mistake, which could result in injury.



Disassembly should only be carried out by a qualified technician.



Be sure to wear protective goggles and gloves when handling the lubricating oil and grease, so that they do not get into your eyes or onto your skin, otherwise inflammation may result. Furthermore, do not drink the oil or eat the grease under any circumstances, as they may cause vomiting and diarrhea. Keep the oil out of the reach of children



Use only the proper replacement parts as specified by Brother.



If any safety devices have been removed, be absolutely sure to re-install them to their original positions and check that they operate correctly before using the machine.



Any problems in machine operation which result from unauthorized modifications to the machine will not be covered by the warranty.

4-1. Covers

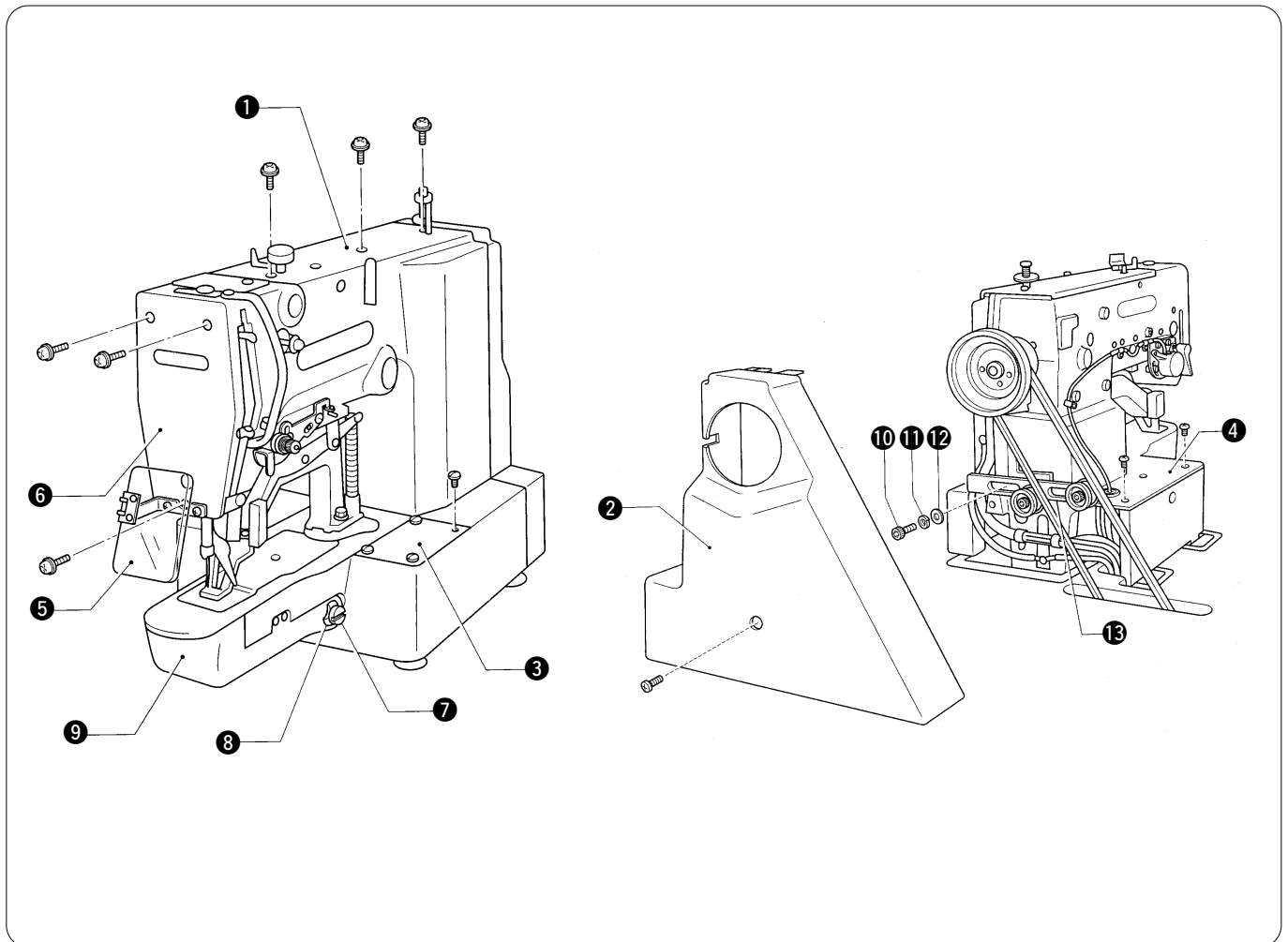

1. Remove the screws and the top cover **1**.
2. Remove the screws, the belt cover **2**, and bed covers (R) **3** and (L) **4**.
3. Remove the screws, the eye guard **5** and the face plate **6**.
4. Remove the stud screw **7** and the washer **8** on each side, and the shuttle race cover **9**.
5. Remove the bolt **10**, spring washer **11**, the washer **12**, and tension pulley **13**.

4-2. Presser arm mechanism

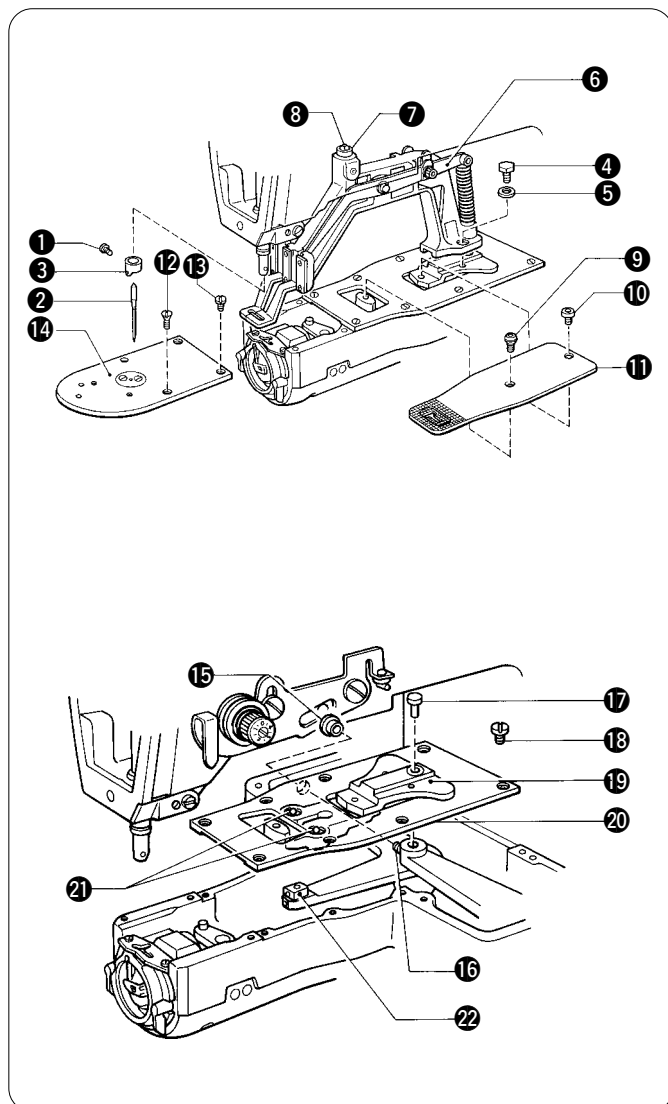

1. Remove the set screw ①, the needle ② and the needle bar thread guide ③.
2. Remove the bolt ④ and the washer ⑤ on each side, and the presser arm ⑥.
* Pay attention not to let the ball bearing ⑧ of the presser arm support shaft ⑦ fall.
3. Remove the flat screw ⑨, the screw ⑩ and the feed plate ⑪.
4. Remove the two flat screws ⑫, the two screws ⑬, and the needle plate ⑭.

5. Remove the rubber cap ⑮, the set screw ⑯, and the tack width feed shaft ⑰.
6. Remove the eight screws ⑱, and the feed bar guide plate ⑳ along with the feed bracket ㉑.
* Pay attention not to let the ball bearing ㉒ fall.
7. Remove the slide block ㉒ from the pin.

4-3. Shuttle hook mechanism

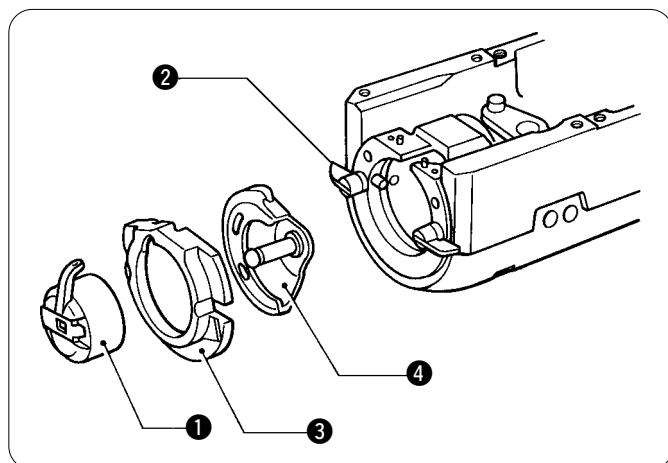

1. Remove the bobbin case ① by pulling its release lever.
2. Open the setting claw ② on each side, and remove the shuttle race ③ along with the shuttle hook ④.

4. DISASSEMBLY

4-4. Needle bar mechanism

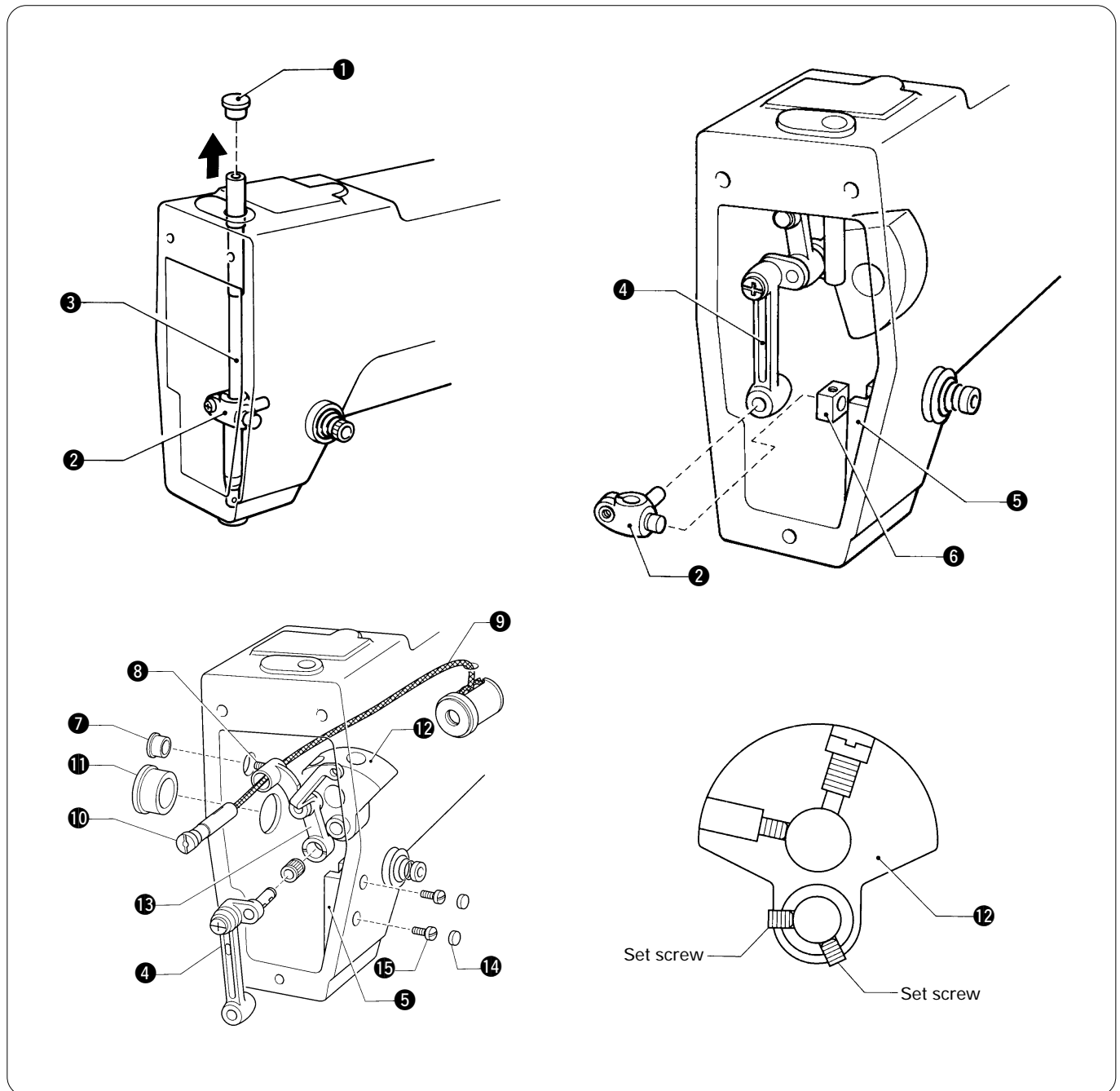

1. Remove the rubber cap **1**.
2. Loosen the screw of the needle bar clamp **2**, and remove the needle bar **3** through the machine top.
3. Remove the needle bar clamp **2** from the thread take-up lever **4**.
* Remove the needle bar guide slide block **6** from the needle bar guide **5**.
4. Remove the rubber cap **7**, loosen the set screw **8**, and remove the wick **9** and the thread take-up support stud **10**.
5. Remove the oil cap **11**, loosen the two set screws of the thread take-up crank **12**, and remove the thread take-up lever **4**.
* The thread take-up assembly **13** will come off.
6. Remove the rubber cap **14**, the screw **15**, and the needle bar guide **5**.
* Do not remove them if possible to prevent the machine from overheating due to needle bar rubbing.

4-5. Upper shaft mechanism

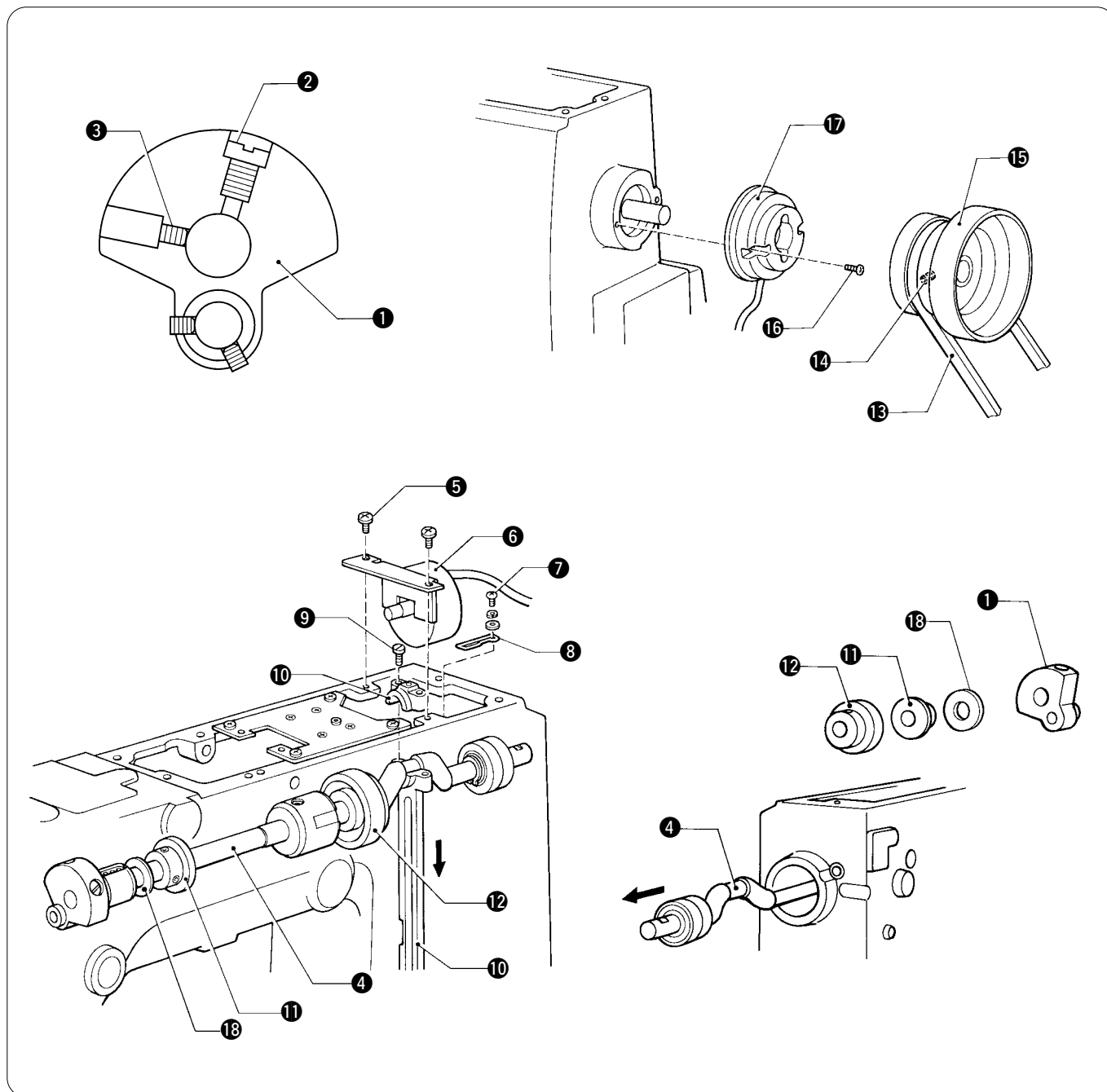

1. Loosen the screw **2** and the set screw **3** of the thread take-up crank **1**.
* The screw **2** should be loosened until its end comes off the upper shaft **4**.
2. Remove the screw **5**, and the thread trimming solenoid **6**.
3. Remove the screw **7**, and the wick support **8**.
4. Remove the screw **9**, and the crank rod **10**.
* At this time, lower the lower part of crank rod **10** in the direction of the arrow.
5. Loosen the set screws of the bobbin winder pulley **11** and the thread trimmer cam **12**.
6. Remove the V-belt **13**, loosen the set screw **14**, and remove the pulley **15**.
7. Remove the screw **16** and the synchronizer **17**.
8. Remove the upper shaft **4** in the direction of the arrow.
* After that, remove the thread take-up crank **1**, the washer **13**, the bobbin winder pulley **11**, and the thread trimmer cam **12** from the upper shaft **4**, in this order.

4. DISASSEMBLY

4-6. Lower shaft mechanism

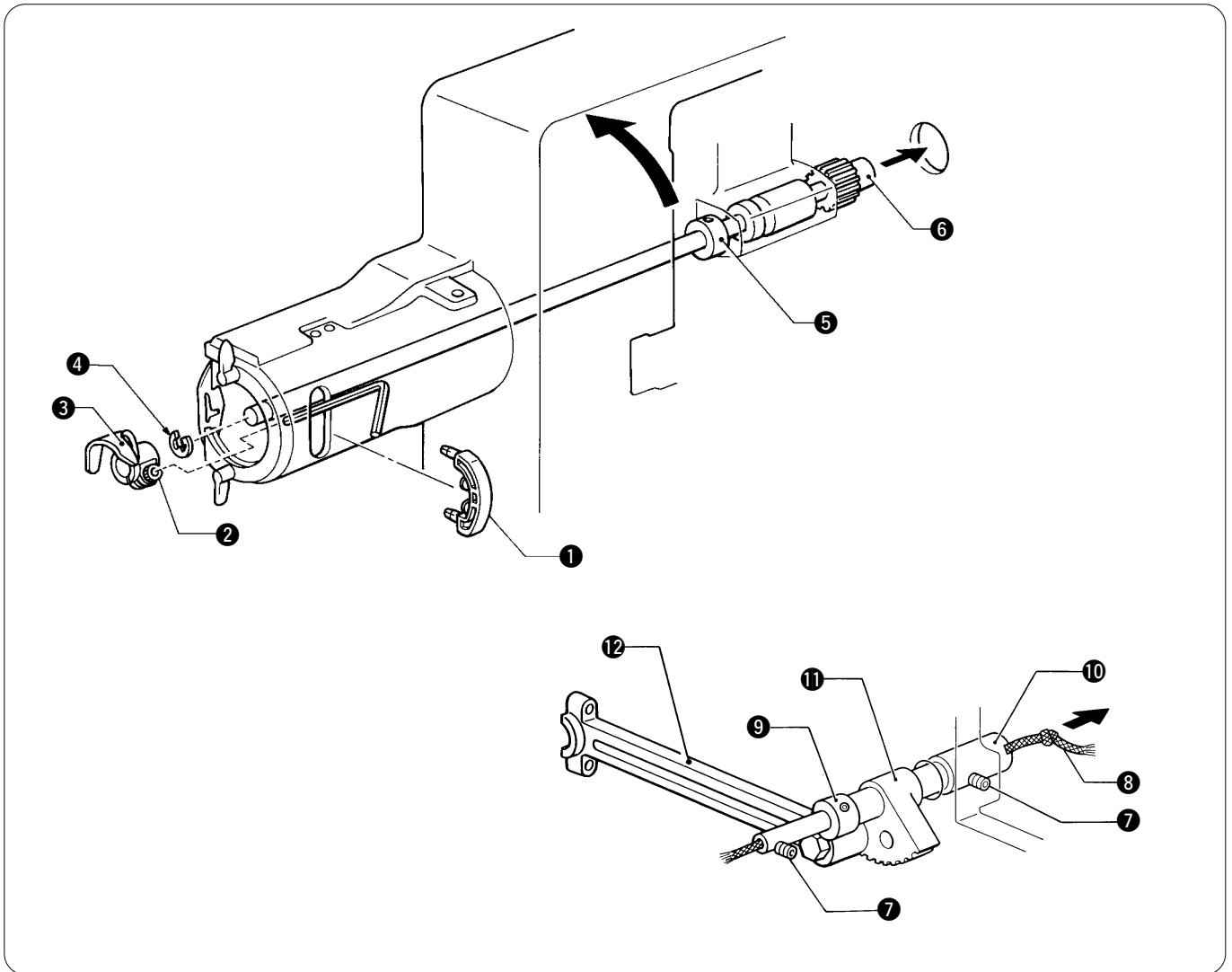

1. Tilt the machine head until it stops.
2. Remove the felt support ①.
3. Loosen the screw ② and remove the driver ③ and the retaining ring ④.
4. Loosen the set screw of the set screw collar ⑤, and remove the lower shaft assembly ⑥ from the rear of the machine.
* The set screw collar ⑤ will come off.
5. Loosen the two set screws ⑦.
6. Untie the wick ⑧, loosen the set screw of the set screw collar ⑨, and remove the rock gear shaft ⑩ from the rear of the machine.
7. Remove the set screw collar ⑨, the rock gear ⑪, and the crank rod ⑫.

4-7. Feed mechanism (1)

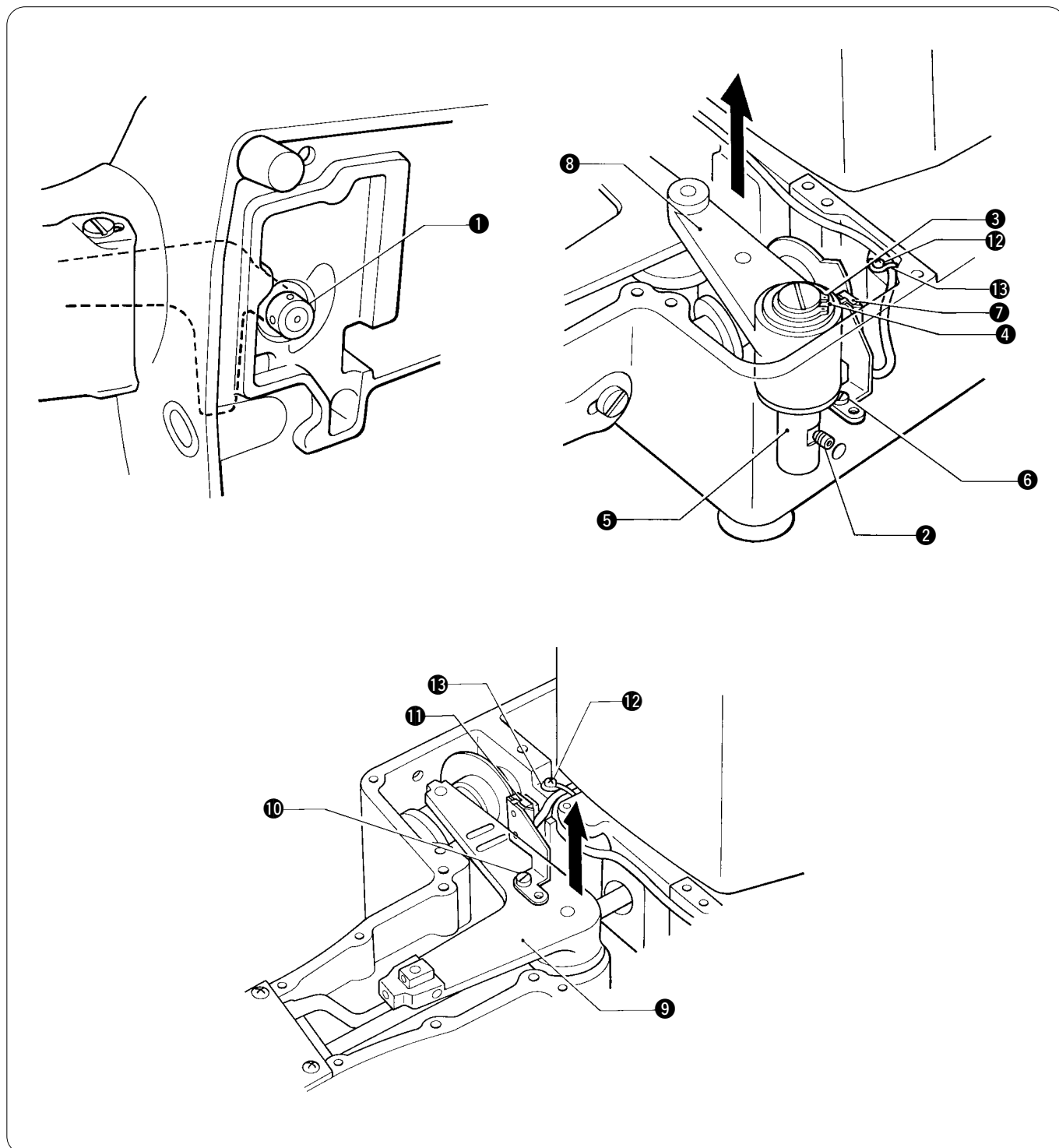

1. With the machine head tilted, loosen the set screw of the set screw collar **1**, and remove the latter.
2. Return the machine to its original position.
3. Loosen the set screw **2**, and remove the tack width lever shaft **5** and the washer **4** from above.
* When the tack width lever shaft **5** is not removed, remove the retaining ring **3** and the washer **4**.
4. Remove the Y feed lever **8** by lifting it in the direction of the arrow.
* Remember to remove the washer **4** under the Y feed lever **8**.
5. Remove the screw **6**, and home position sensor Y **7**.
6. Remove the X feed lever **9** by lifting it in the direction of the arrow.
7. Remove the screw **10** and home position sensor X **11**.
8. Remove the screw **12**, the cord support **13**, and home position sensors Y **7** and X **11**.

4. DISASSEMBLY

Feed mechanism (2)

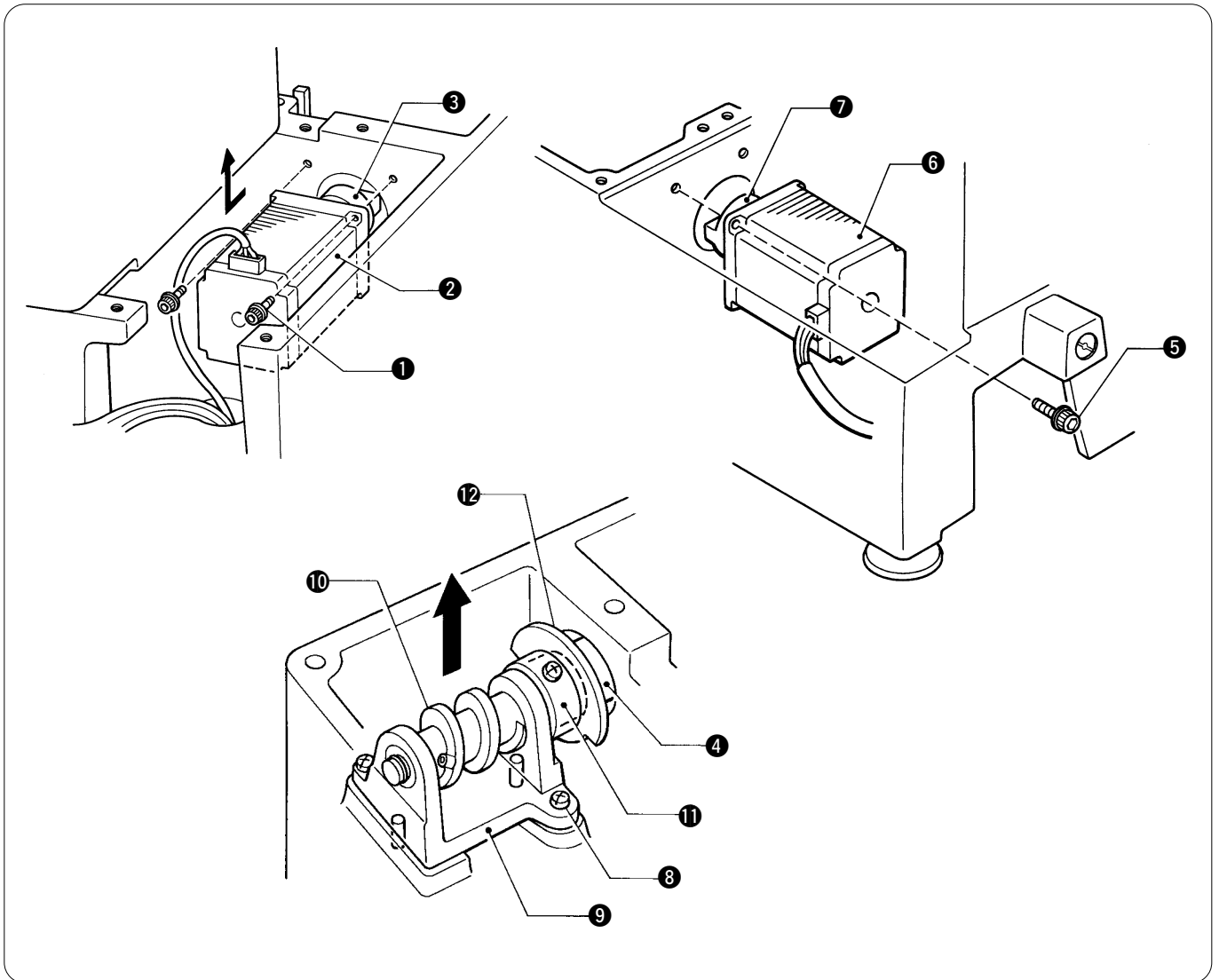

1. Remove the four screws ①, the X-pulse motor assembly ②, coupling hub 6.35 ③, and the coupling spacer ④.
2. Tilt the machine head until it stops.
3. Remove the screw ⑤, the Y-pulse motor assembly ⑥, coupling hub 6.35 ⑦, and the coupling spacer ④.
4. Return the machine head to its original position.
5. For the X direction, remove the screw ⑧, the feed cam bracket ⑨, feed cam X ⑩, coupling hub 8 ⑪, and the feed home position dog ⑫ by lifting them from above.
6. Repeat step 5 for the Y direction.

Feed mechanism (3)

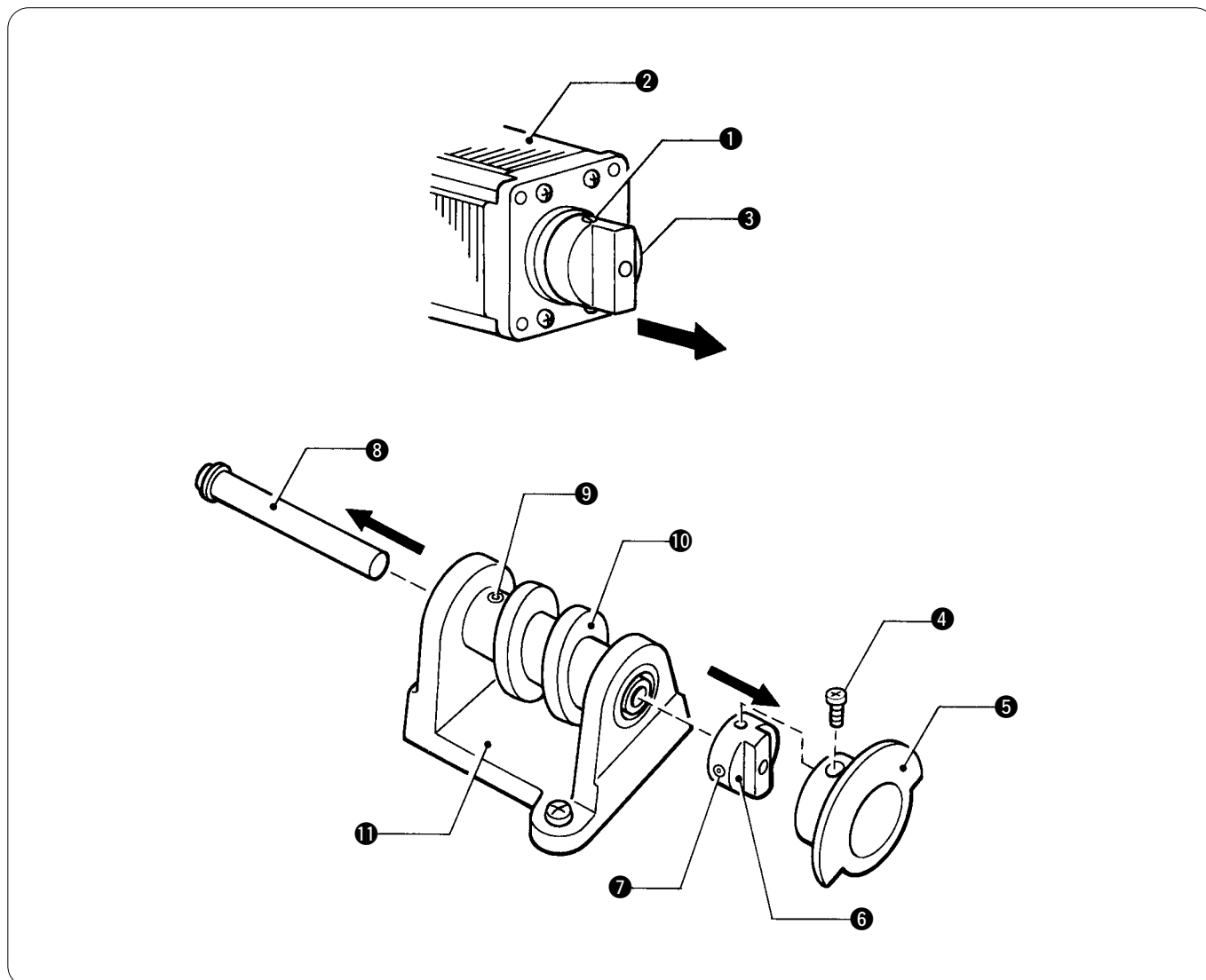

1. Loosen the set screw **1**, and remove coupling hub 6.35 **3** from the shaft of the pulse motor **2**.
2. Remove the screw **4**, and the feed home position dog **5** from coupling **8** **6**.
3. Loosen the set screw **7** and remove coupling hub **8** **6** from the cam shaft **8**.
4. Loosen the set screw **9**, and remove the cam shaft **8**.
5. Remove the feed cam **10** from the feed cam bracket **11**.

4. DISASSEMBLY

4-8. Presser mechanism

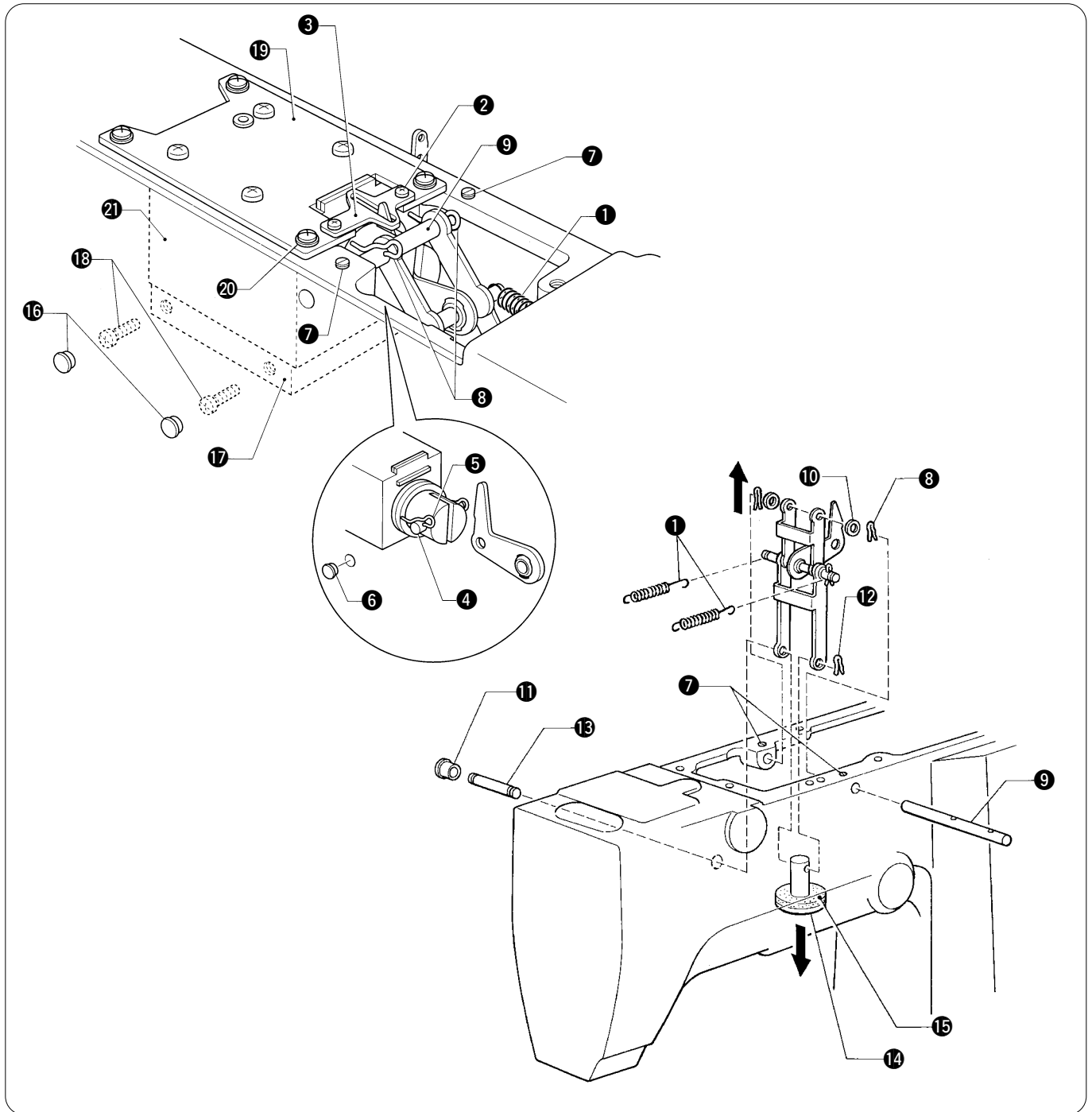

1. Remove the two spring **1**.
2. Remove the two screws **2** and the guide **3**.
3. Remove the snap pins **5** of link shaft D **4**, and the rubber cap **6**, and then link shaft D **4** through the hole in the arm.
4. Loosen the set screw **7**, and remove the snap pins **8**, link shaft A **9**, and the washers **10**.
5. Remove the rubber cap **11**, the snap pin **12**, and link shaft C **13**.
Be sure to hold the presser plate **14** and the presser bar lifter lever rubber **15** so that they do not fall.
6. Remove the presser lifter link-related parts upward.
7. Remove the two rubber caps **16**, and the two screws **18** of the solenoid setting plate, B **17**.
8. Remove the four screws **20** of the solenoid setting plate, A **19**, and the presser foot lifter solenoid **21**.

4-9. Thread wiper mechanism

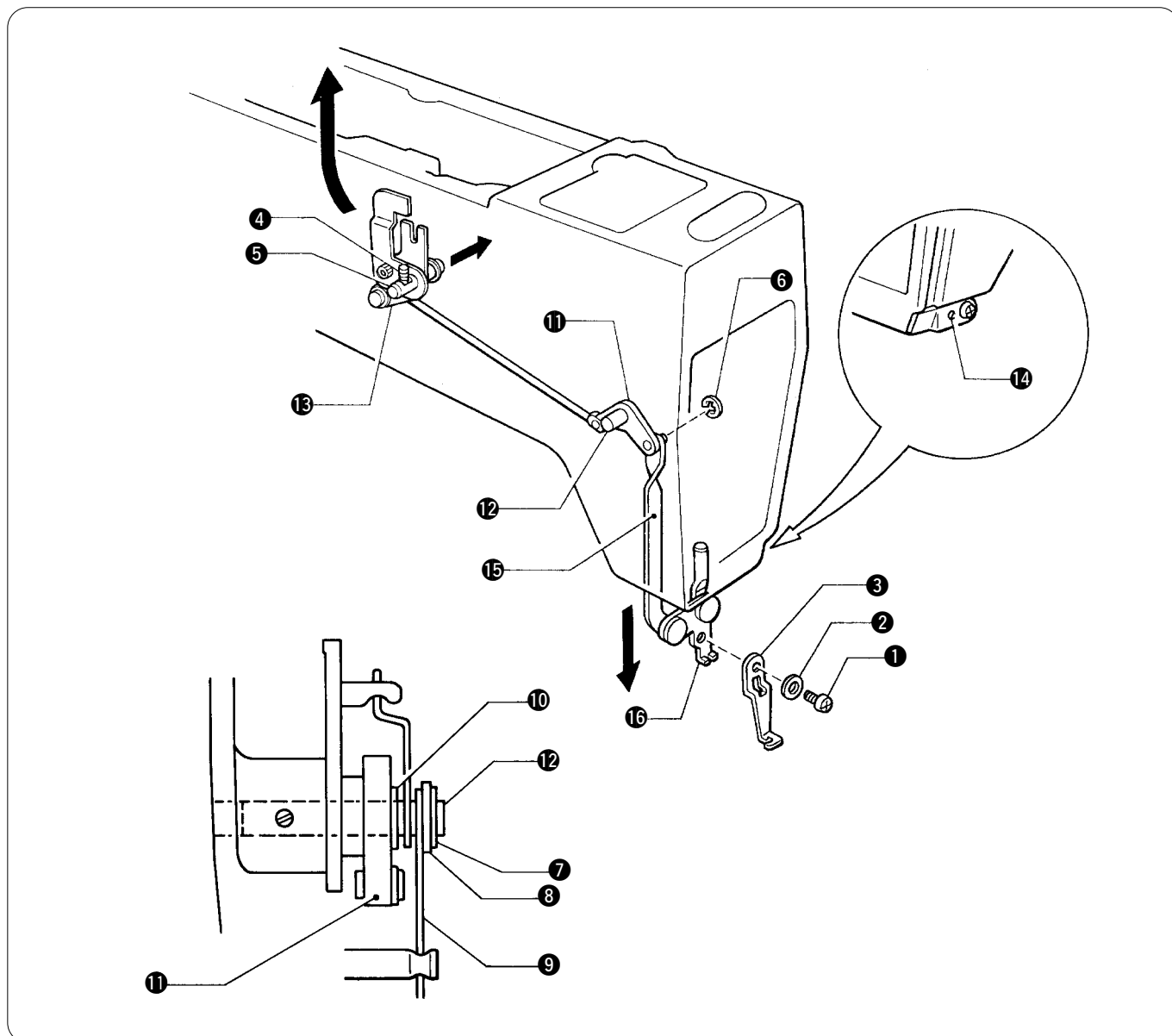

1. Remove the screw **1**, the washer **2**, and the thread wiper **3**.
2. Loosen the set screw **4**, and remove the thread wiper shaft **5**.
3. Remove the retaining ring **6**.
4. Remove the retaining ring **7**, the washer **8**, the spring **9**, and the retaining ring **10**. Then remove the thread wiper rod assembly **11** from the presser bar lifter lever shaft **12**.
5. Remove the thread wiper assembly **11** and the thread wiper driving lever **13** by lifting them upward.
6. Loosen the set screw **14**, and remove the thread wiper link **15** and the thread wiper arm **16** by pulling them downward.

4. DISASSEMBLY

4-10. Thread nipper mechanism

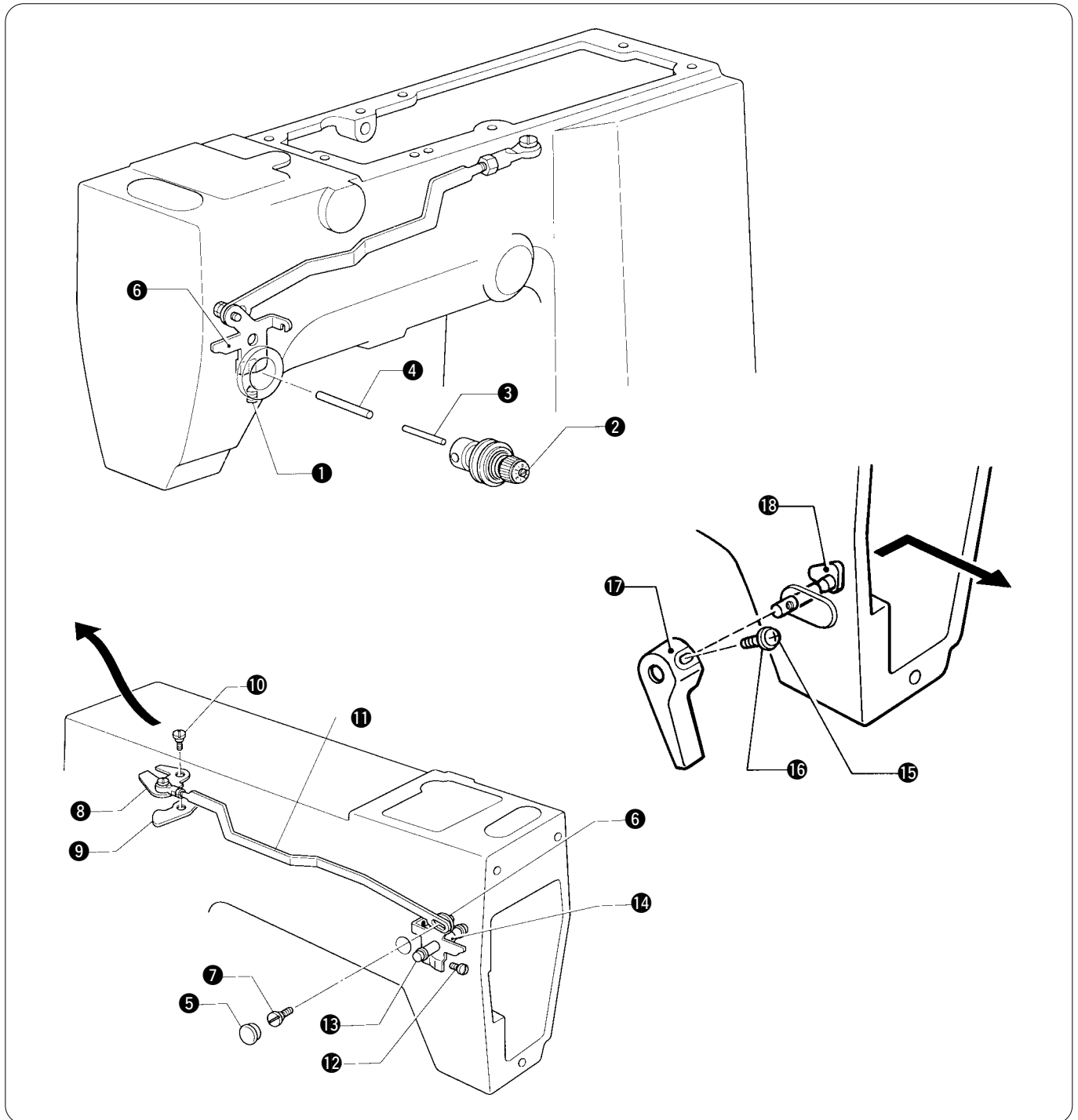

1. Loosen the set screw ①, and remove the thread tension assembly ②, the pin ③, and the tension release bar ④.
2. Remove the rubber cap ⑤, the stud screw ⑦ of the thread tension release lever ⑥, the stud screw ⑩ securing both tension release lever (U) ⑧ and the pushing lever ⑨, and then remove the tension release rod ⑪ and the pushing lever ⑨ in the direction of the arrow.
3. Loosen the set screw ⑫, and remove the presser bar lifter lever shaft ⑬, collar ⑭ and tension release lever ⑥.
4. Remove the screw ⑮, the washer ⑯, and the presser bar lifter lever ⑰.
5. Remove the presser bar lifter crank ⑱ in the direction of the arrow.

4-11. Thread take-up mechanism

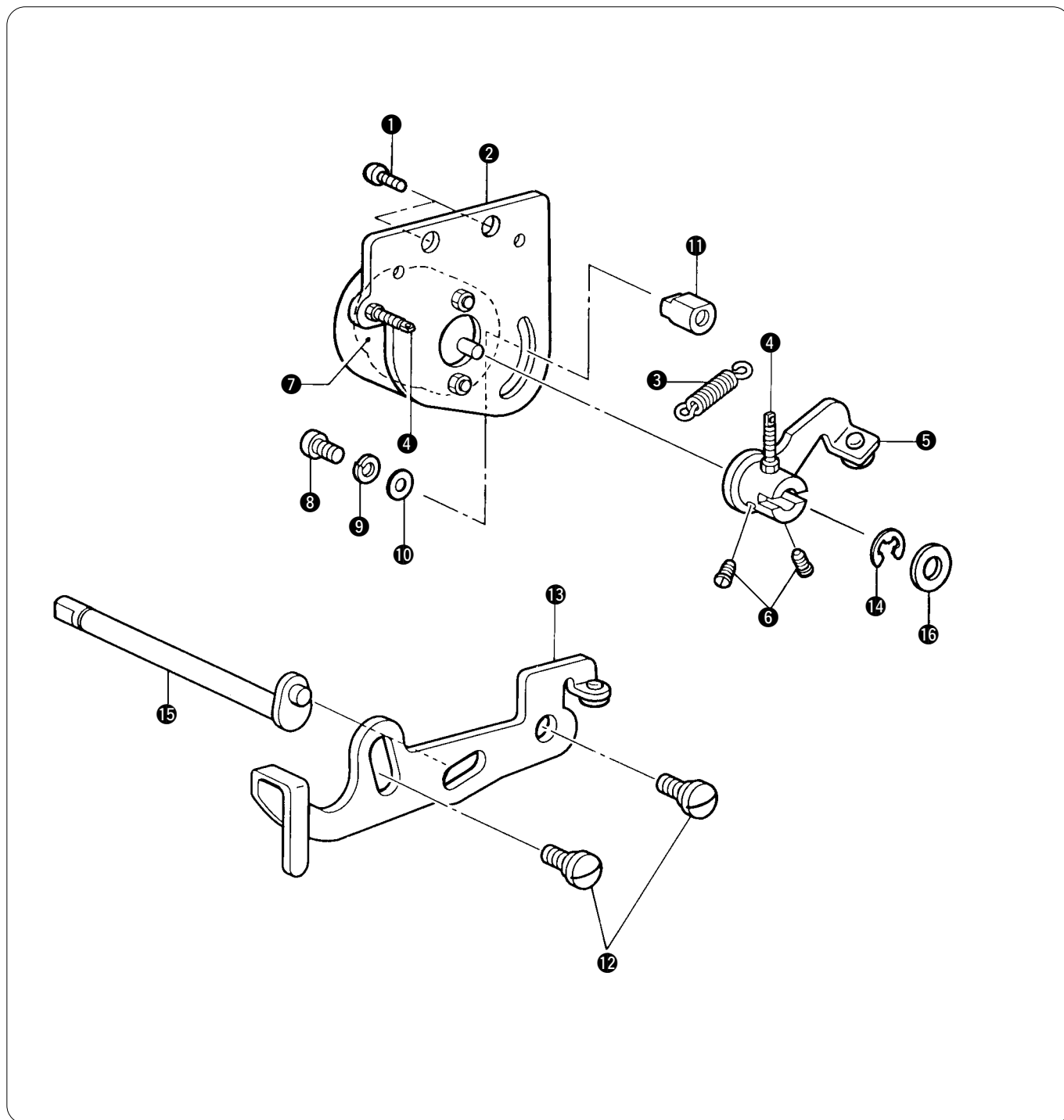

1. Remove the two screws **1**, and the solenoid setting plate **2** from the machine head.
2. Remove the spring **3** from the spring hook **4**.
3. Loosen the set screw **6** of the solenoid joint **5**, and remove the solenoid joint **5** from the thread take-up solenoid **7**.
4. Remove the screw **8**, the spring washer **9**, the washer **10** and the nut, 3.57 **11** from the solenoid setting plate **2**.
5. Remove the two stud screws **12**, and the thread take-up lever **13**.
6. Remove the retaining ring **14**, the crankshaft **15** and the washer **16**.

4-12. Thread trimmer mechanism

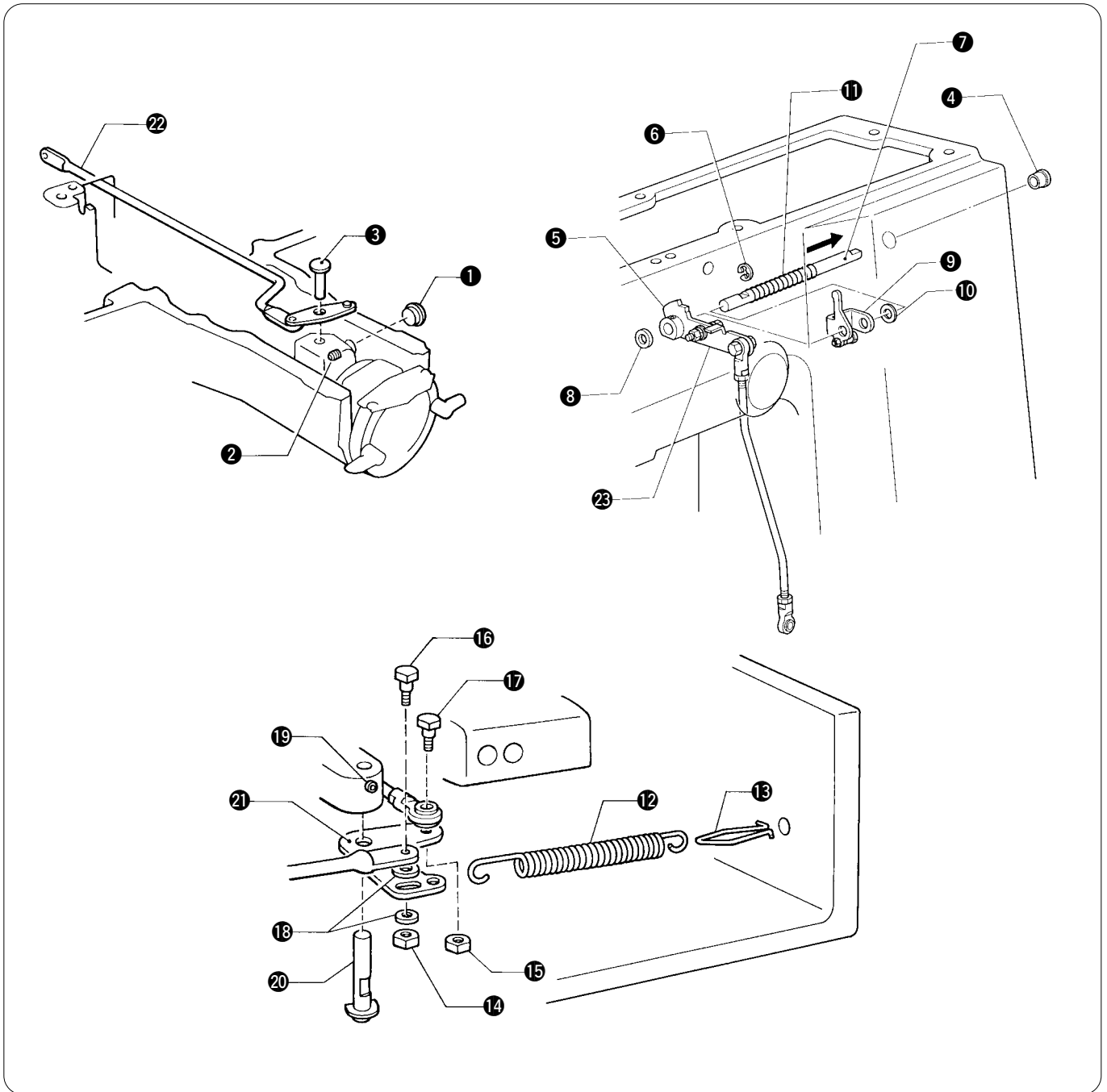

1. Remove the rubber cap **1**, loosen the set screw **2**, and remove the connecting rod lever shaft **3**.
2. Remove the oil cap **4**, loosen the set screw **5**, and remove the retaining ring **6**.
3. Remove the driving lever shaft **7** by pulling it in the direction of the arrow. Then remove the cushion **8**, the tension release driving lever **9**, the washer **10** and the spring **11** from the shaft.
4. Tilt the machine head until it stops.
5. Remove the thread trimmer return spring **12** and the spring hook **13**.
6. Remove the nuts **14** and **15**, the stud screws **16** and **17**, and the two washers **18**.
7. Loosen the set screw **19**, and remove the lever shaft **20** and the thread trimmer lever **21**.
8. Return the machine head to its original position, and remove the connecting rod lever **22** and the thread trimmer driving lever **23**.

5. ASSEMBLY

5-1. Thread trimmer mechanism (1)

During assembly, apply grease to the portions indicated by the white arrows.

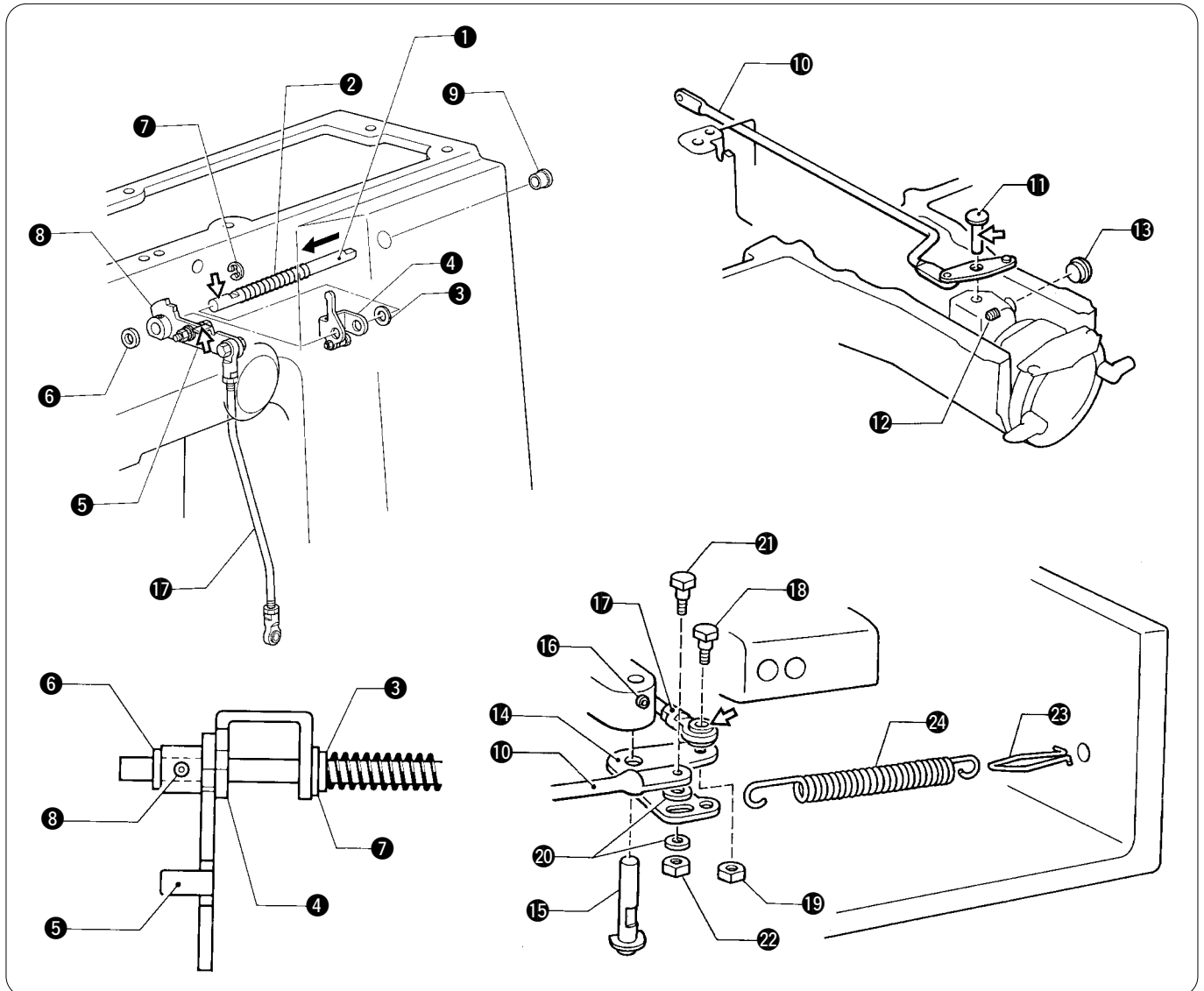

1. Insert the driving lever shaft **1** into the machine. Place the spring **2**, the washer **3**, the tension release driving lever **4**, the thread trimmer driving lever **5**, and the cushion **6** on the shaft in this order.
2. Put the retaining ring **7** on the shaft. Press the thread trimmer driving lever **5** against the tension release driving lever **4**. Tighten the set screw **8** on the screw flat.
3. Attach the oil cap **9**.
4. Insert the connecting rod lever **10** into the machine, lightly press the connecting rod lever shaft **11** against the former, then secure them using the set screw **12**.
5. Attach the rubber cap **13**.
6. Tilt the machine head until it stops.
7. Pass the lever shaft **15** with the washer and the retaining ring, through the thread trimmer lever **14**, and tighten the set screw **16** on the screw flat.
8. Attach the thread trimmer rod **17** to the thread trimmer lever **14** using the stud screw **18** and the nut **19**, and also attach the connecting rod lever **10** to the thread trimmer lever **14** using the two washers 4.76 **20**, the stud screw **21** and the nut **23**.
9. Attach the spring hook **23** to the inside of the machine, and connect the thread trimmer return spring **24** to it.
10. Return the machine head to its original position.

5. ASSEMBLY

5-2. Thread nipper mechanism

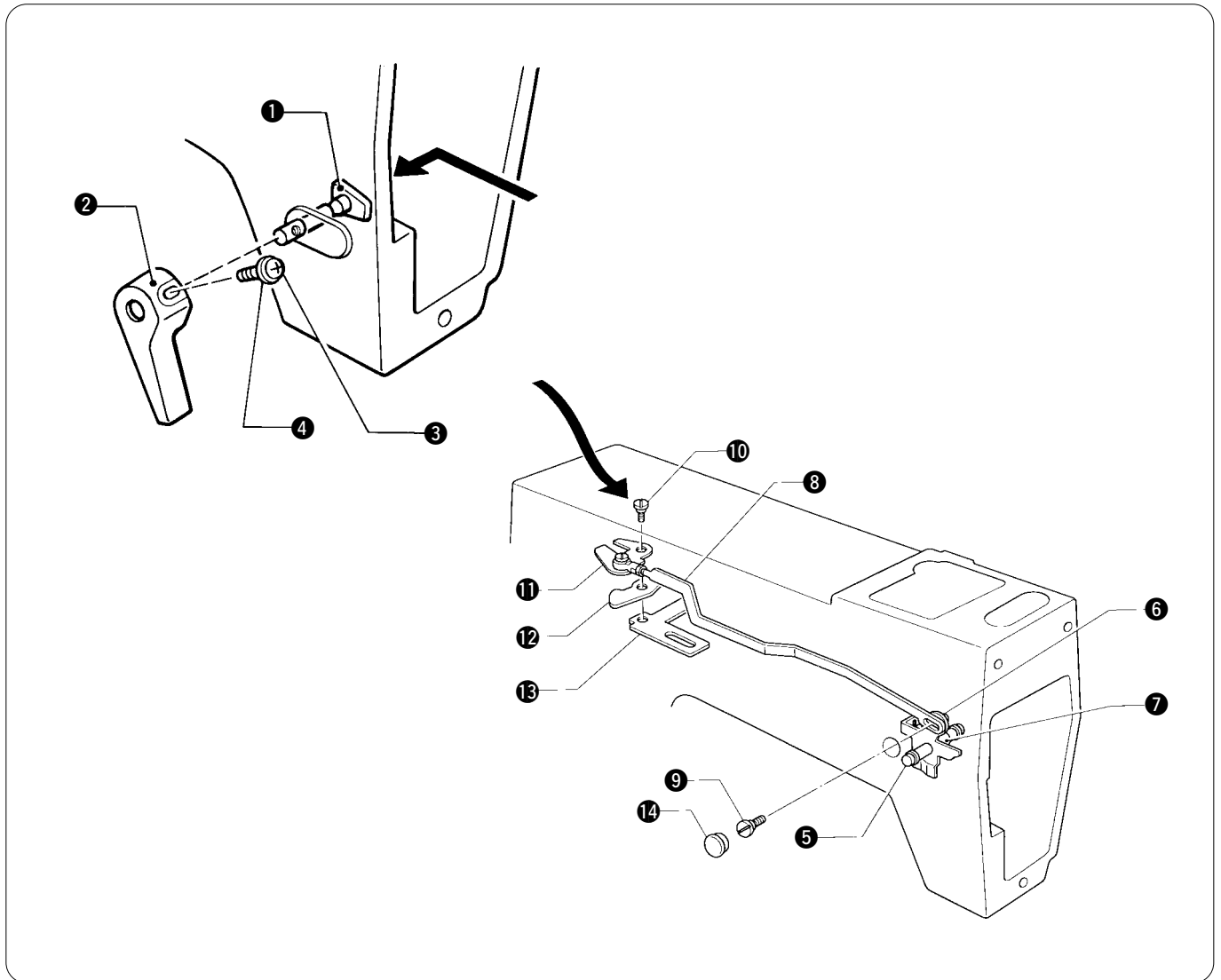

1. Insert the presser bar lifter crank ① into the machine as shown, in the direction of the arrow, attach the presser bar lifter lever ② to it, and secure them using the screw ③ and the washer ④.
* Make sure that the presser bar lifter lever ② moves easily.
2. Insert the presser bar lifter lever shaft ⑤ into the machine, and place the tension release lever ⑥ and collar ⑦ on it.
3. Insert the tension release rod ⑧ into the machine in the direction of the arrow as shown, attach it to the tension release lever ⑥ using the stud screw ⑨, and attach tension release lever (U) ⑪ and the pushing lever ⑫ to the driving lever stopper ⑬ using the stud screw ⑩.
*Apply grease to the engagement portion of the stud screw ⑩.
4. Attach the rubber cap ⑭.

5-3. Thread wiper mechanism (1)

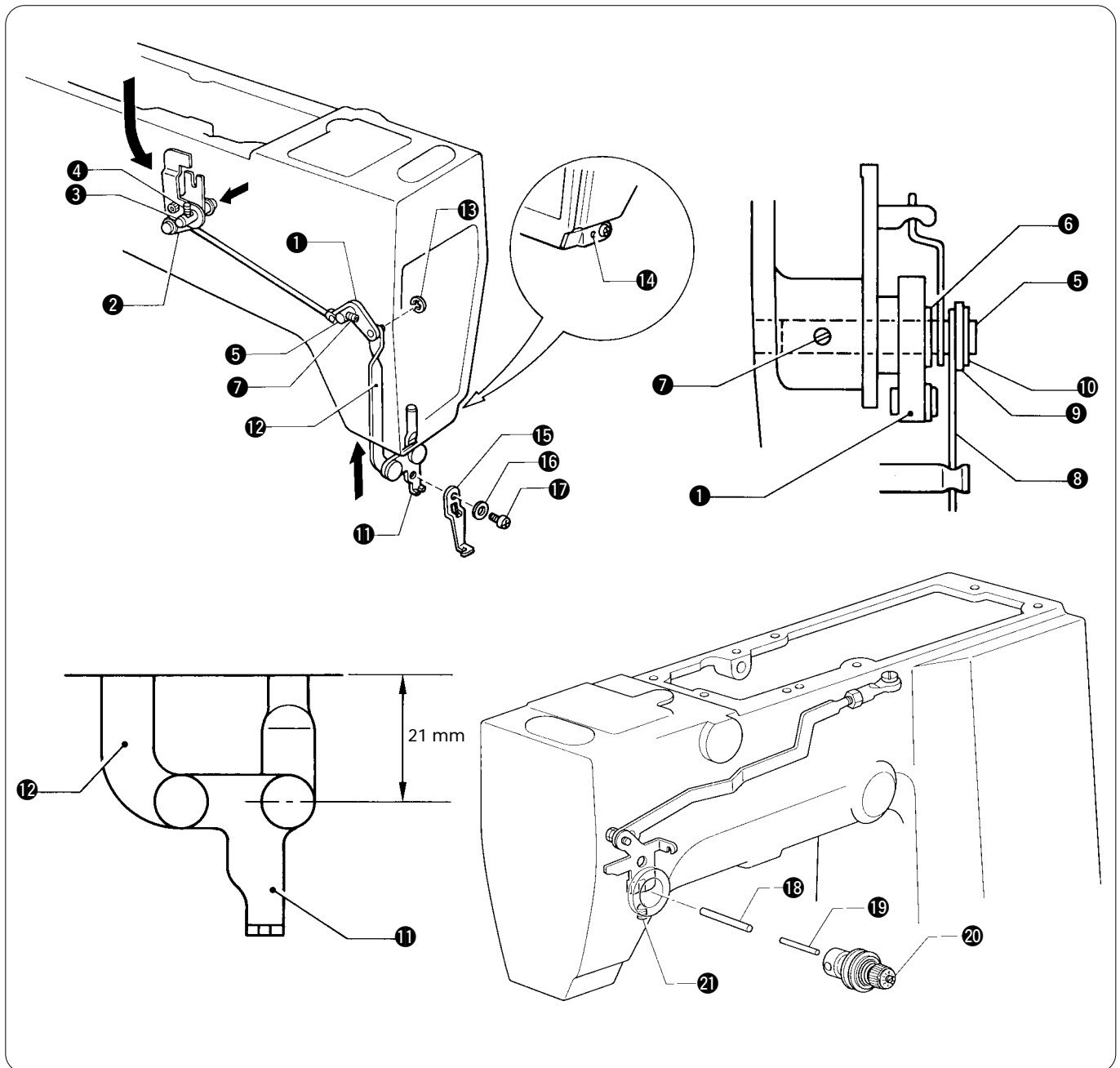

1. Insert the thread wiper rod assembly **1** and the thread wiper driving lever **2** into the machine from above. Fit the thread wiper shaft **3** with retaining rings and washers on the former two, and lightly press them and secure using the set screw **4**.
2. Place the thread wiper rod assembly **1** on the presser bar lifter lever shaft **5**, and fit the retaining ring **6** on it.
3. Lightly press the presser bar lifter lever shaft **5**, and tighten the set screw **7**.
4. Attach the spring **8** as shown in the figure above. Attach the washer **9** and the stop ring **10** to it.
5. Insert the thread wiper arm **11** and the thread wiper link **12** into the machine in the direction of the arrow, and attach the retaining ring **13**.
6. Temporarily tighten the set screw **14** so that the thread wiper arm **11** is positioned 21 mm below from the bottom of the arm.
7. Attach the thread wiper **15** using the washer **16** and the screw **17**.
8. Move the forked portion of the thread wiper driving lever **2**, and check that all of the thread wiper mechanism moves.
9. Insert the tension release bar **18**, the pin **19**, and the thread tension assembly **20** into the machine, and secure them using the set screw **21**.

* Adjust the height of the spring referring to page 4.

NOTE:

If there is no thrust in the thread wiper rod assembly **2** or the thread wiper mechanism operation is sluggish, it may be due to the operation of the presser plate (shown on page 28), and error E-60 may be displayed.

5-4. Thread take-up mechanism

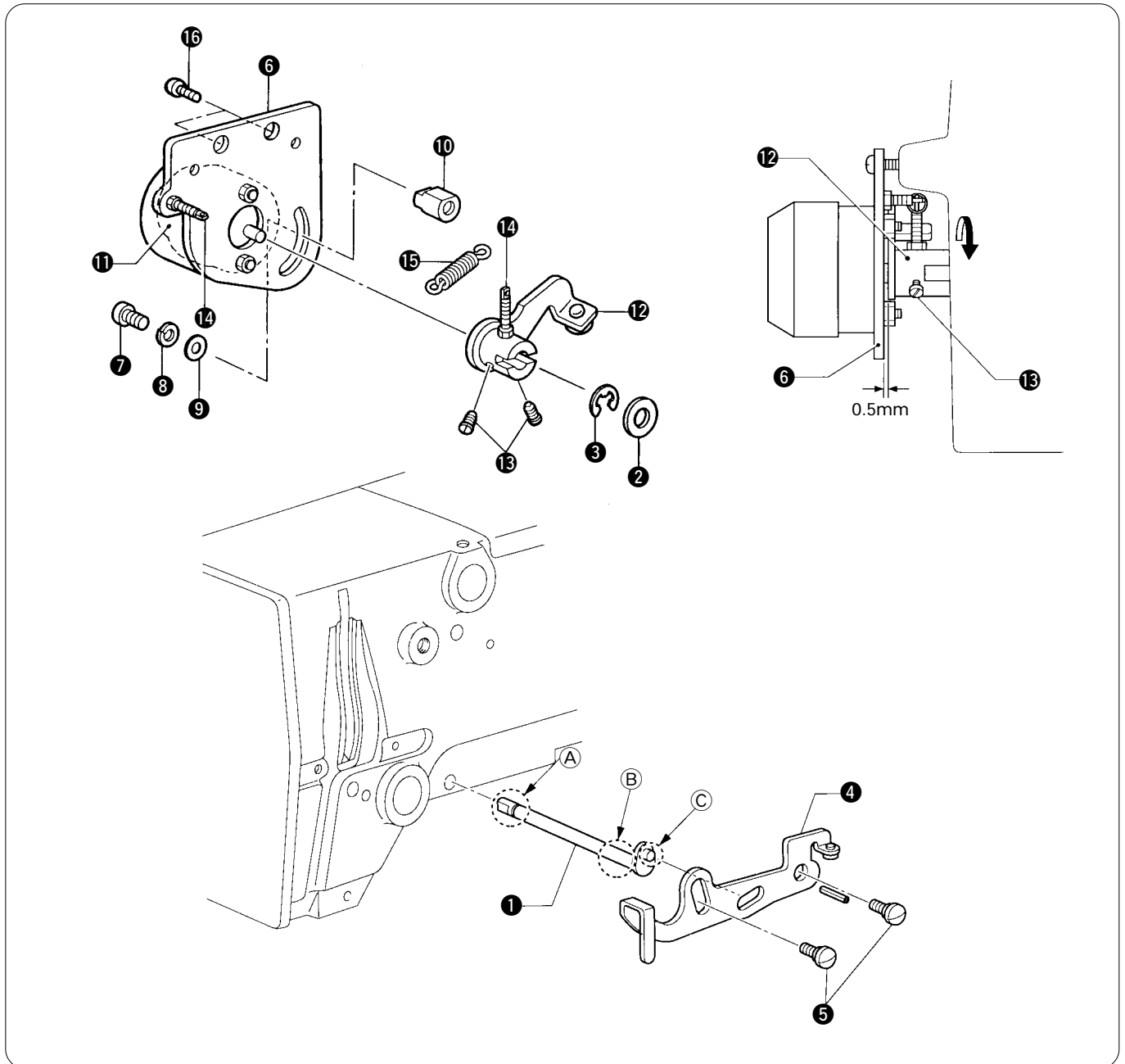

1. Insert the thread take-up lever crank ① into the machine and secure it using the thrust washer ② and the stop ring ③.
* Apply grease to portions A, B, and C of the thread take-up lever crank ①.
2. Attach the thread take-up lever ④ using the stud screw ⑤.
3. Attach the screw ⑦, the spring washer ⑧, the washer ⑨, and nut 3.57 ⑩ to the solenoid setting plate ⑥.
* The screw ⑦ should be temporarily tightened.
4. Temporarily attach the solenoid joint ⑫ to the thread take-up solenoid ⑪ using the set screw ⑬.
5. Attach the spring ⑮ to the spring hook ⑭ of the solenoid setting plate ⑥ and the spring hook ⑭ of the solenoid joint ⑫.
6. Place the thread trimming solenoid joint ⑫ onto the crankshaft ① so that the flat surfaces are aligned, and then install the solenoid setting plate ⑥ to the machine head with the two screws ⑯.
7. Turn the thread trimming solenoid joint ⑫ forward you in the direction of the arrow while tightening the two set screws ⑬ of the thread trimming solenoid joint ⑫ so that the gap between the solenoid setting plate ⑥ and the thread trimming solenoid joint ⑫ is 0.5 mm.
* Check that the thread take-up lever ④ operates smoothly at this time. If the movement is stiff, damage to the solenoid may result.
If the movement is stiff, loosen the two screws ⑯ and make fine adjustments to the position of the solenoid setting plate ⑥ so that the thread take-up lever ④ can operate smoothly.

5-5. Presser mechanism

During assembly, apply grease to the necessary portions while referring to the next page.

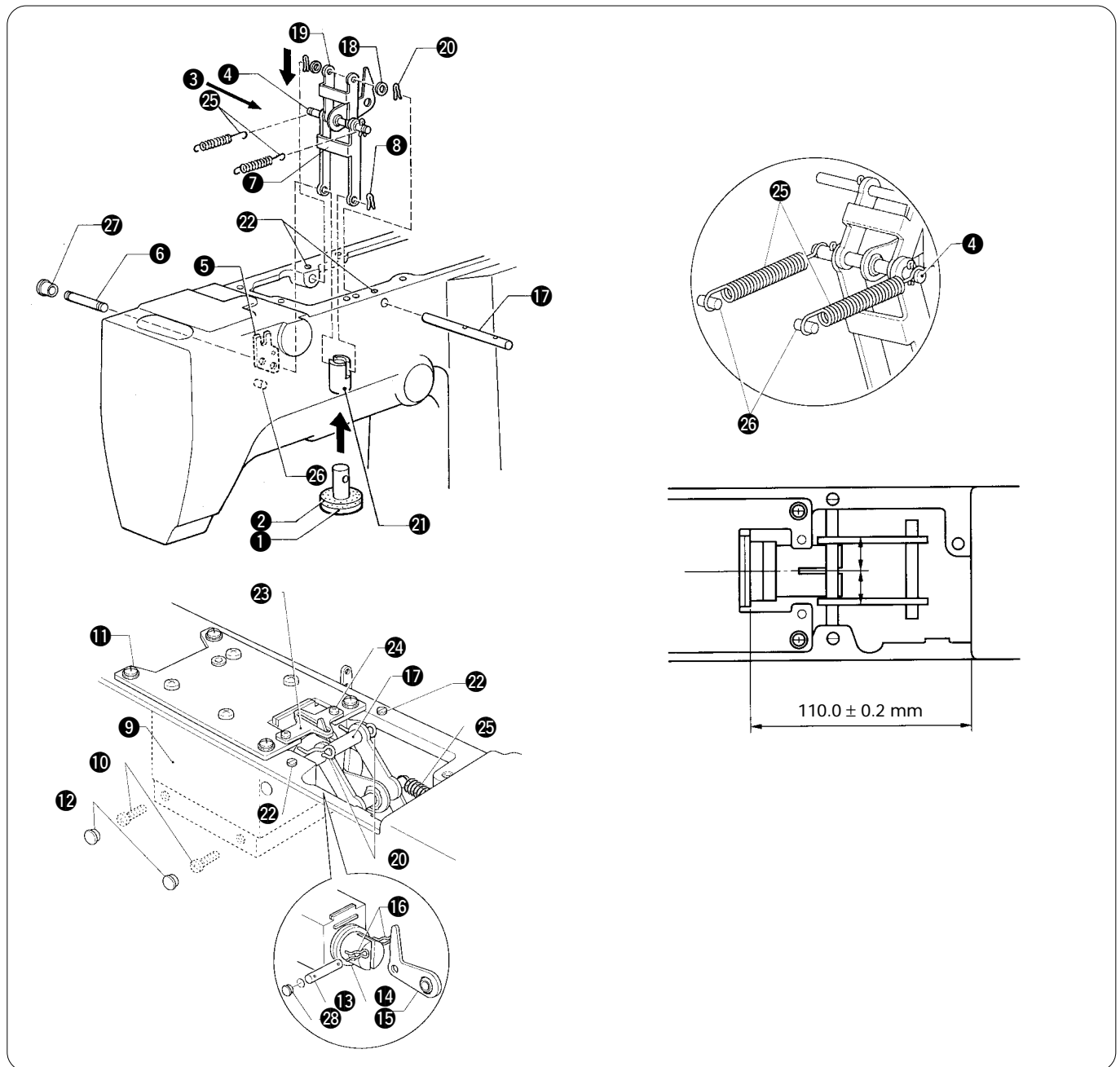

1. Attach the presser plate **1** to the presser bar lifter lever rubber **2**, and insert them from the bottom of the arm.
2. Insert the presser lifter link-related parts **3** from the top into the arm, fit link shaft B **4** into the forked portion of the thread wiper driving lever **5**, and pass link shaft C **6** through link B **7** and the presser plate **1**.
3. Fit the snap pins **8** on both ends of link shaft C **6**.
4. Attach the presser solenoid **9** to the top of the arm.
5. Tighten the screws **10** and **11** in this order when the presser bar lifter solenoid **9** is 11.0 ± 0.2 mm away from the end of the arm, and insert the rubber cap **12** into the hole on the side of the arm.
6. Pass link shaft D **13** through the hole in the arm. Insert it into the holes in the plunger **14** and link C **15**, and attach the snap pins **16**.
7. Insert link shaft A **17** into the machine, and pass it through the washers **18** and link A **19**.
8. Attach the snap pins **20** to the outside of the washers **18** that are on both ends of link shaft A **17**.
9. Secure link shaft A **17** using the set screw **22** so that link B **7** is centered in the bush **21**.
10. Attach the guide **23** using the screw **24**.
11. Attach the two springs **25** to link shaft B **4** and the two pins **26**.
* Press the presser lifter link-related parts **3** by hand to make sure that they can move easily.
12. Attach the rubber caps **27** and **28**.

5. ASSEMBLY

If the presser mechanism is sluggish, it may not move well vertically, resulting in occurrence of error E-60. Make sure that it moves easily, and apply grease to sliding portions of parts before assembly.

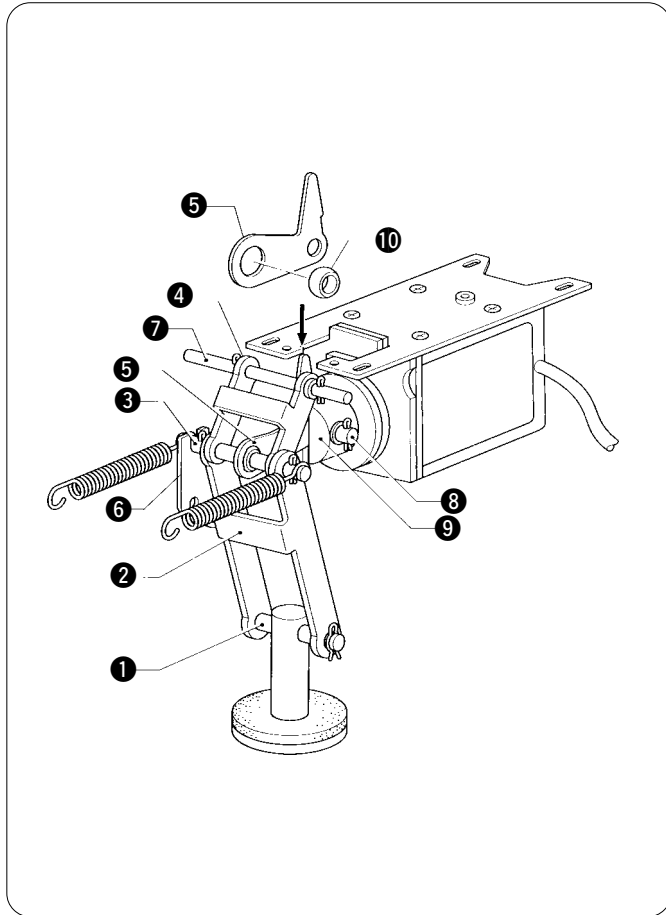

1. Sliding portions of link shaft C ① and link B ②
2. Sliding portions of link shaft B ③, link B ②, link A ④, and link (C) assy ⑤
3. Forked portion of the wiper driving lever ⑥
4. Sliding portions of link shaft A ⑦ and link A ④
5. Sliding portions of link shaft D ⑧, link (C) assy ⑤
6. Forked portion of the plunger ⑨ where link C assy ⑤ is fitted
7. Outer and inner surfaces of spherical bush ⑩ to be attached to link C assy ⑤

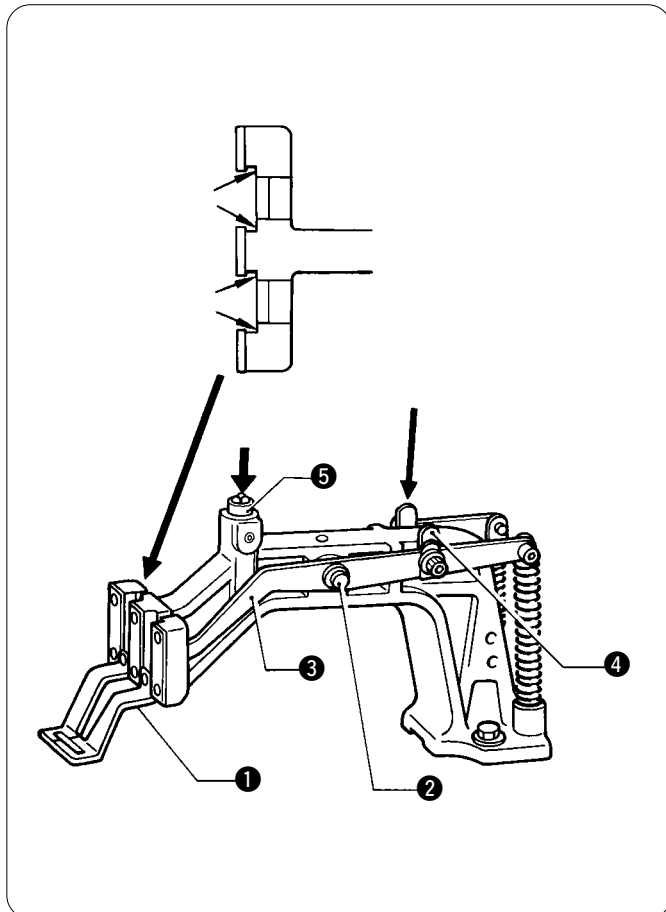

1. Sliding portion of the work clamp ① (Apply small amount of grease.)
2. Sliding portions of the presser arm lever ② and presser arm levers R and L ③
3. Round portion of the presser arm lever plate ④
4. Bearing ball of the presser arm support shaft ⑤

5-6. Feed mechanism (1)

Assembly steps of the feed mechanism are the same for X and Y directions. Feed cams X and Y are similar. Be sure to check their respective markings.

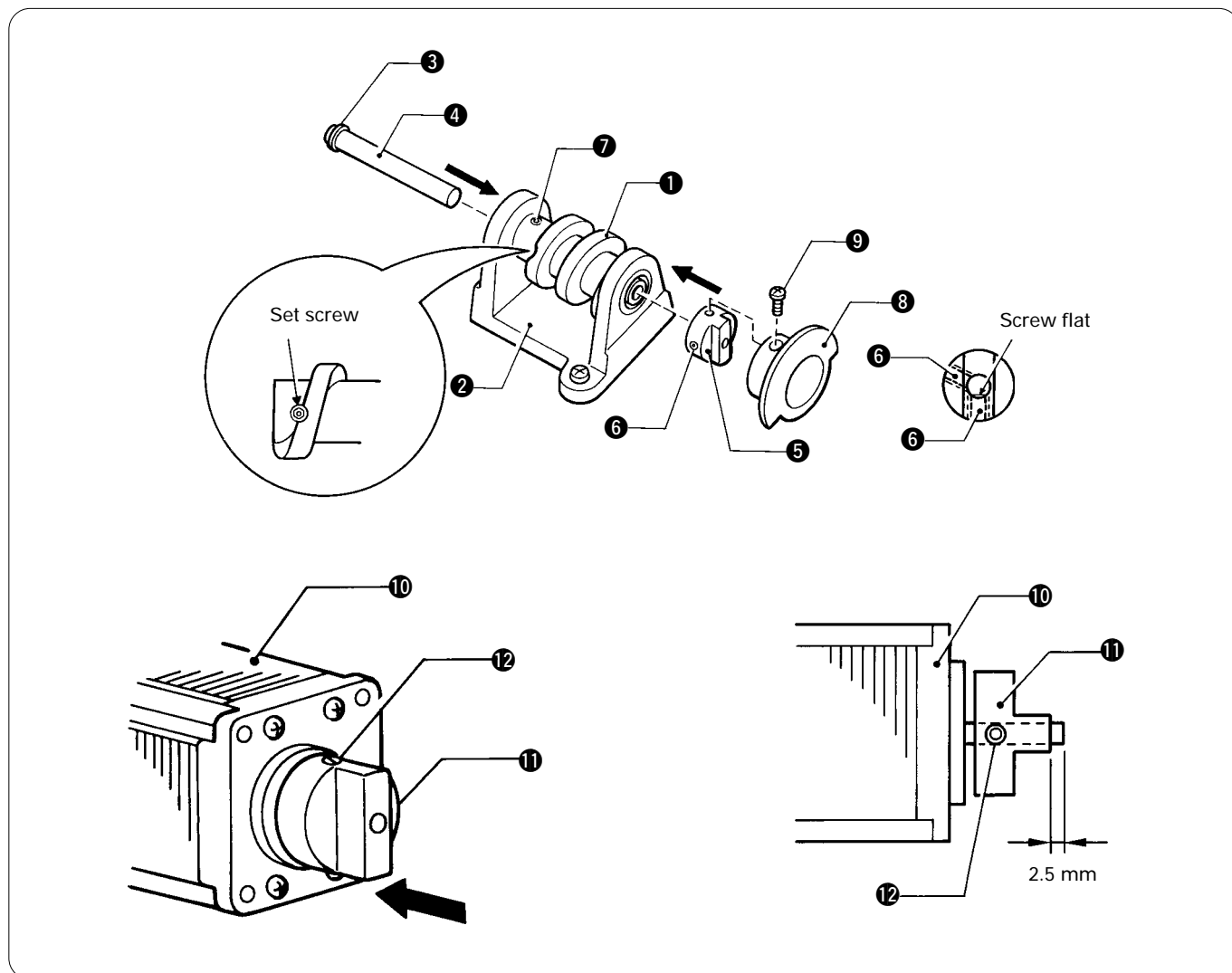

1. Insert the feed cam **1** into the feed cam bracket **2**, and pass the cam shaft **4** with the retaining ring **3** attached, through them.
2. Fit coupling hub **8** **5** on the cam shaft **4** so that there is no end play, adjust the set screw **6** on the screw flat, and tighten it.
3. Adjust the set screw **7** of the feed cam **1** on the screw flat, and tighten it so that the feed cam **1** rotates easily.
4. Fit the feed home position dog **8** on coupling hub **8** **5**, and tighten the screw **9** in the center of the slot.
5. Fit coupling hub 6.35 **11** on the shaft of the pulse motor **10**, and tighten the set screw **12** until the shaft is protruding 2.5 mm.

Feed mechanism (2)

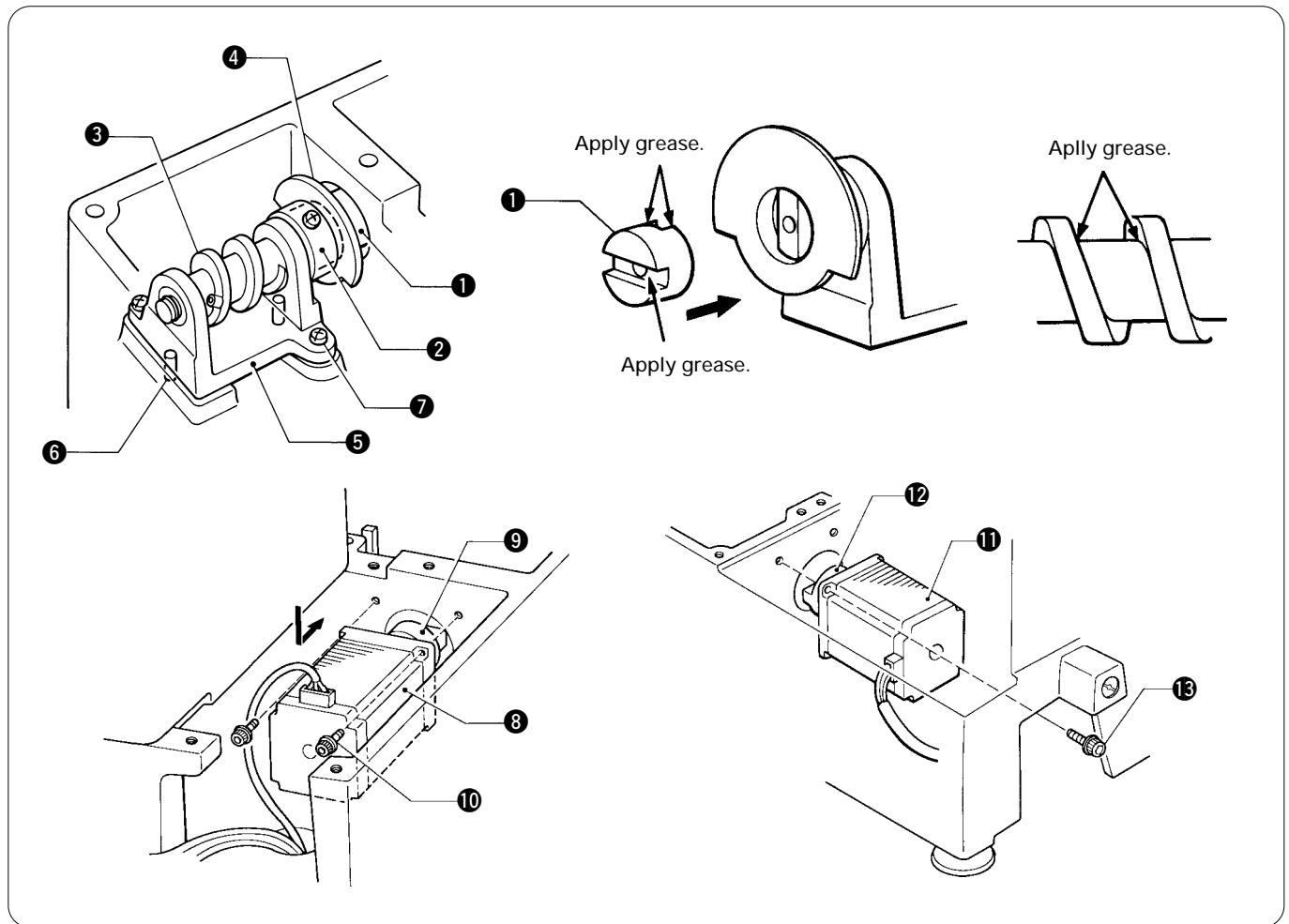

1. Apply grease to the coupling spacer ①, and fit it in coupling hub 8 ②, fit the feed cam bracket ⑤ with the feed cam ③ and the feed home position dog ④ on the locator pin ⑥, and secure them using the screw ⑦.
2. Repeat above steps for Y direction.
3. Adjust the angle of coupling hub 6.35 ⑨ of the pulse motor, X ⑧ to that of the coupling spacer ①. Pass the former through the machine wall, and secure it using the screw ⑩.
4. Tilt the machine head until it stops.
5. Adjust the angle of coupling hub 6.35 ⑫ of the pulse motor, Y ⑪ to that of the coupling spacer ①. Pass the former through the machine wall, and secure it using the screw ⑬.
6. Return the machine head to its original position.
7. Apply grease to the circumference of the feed cam ③.

Feed mechanism (3)

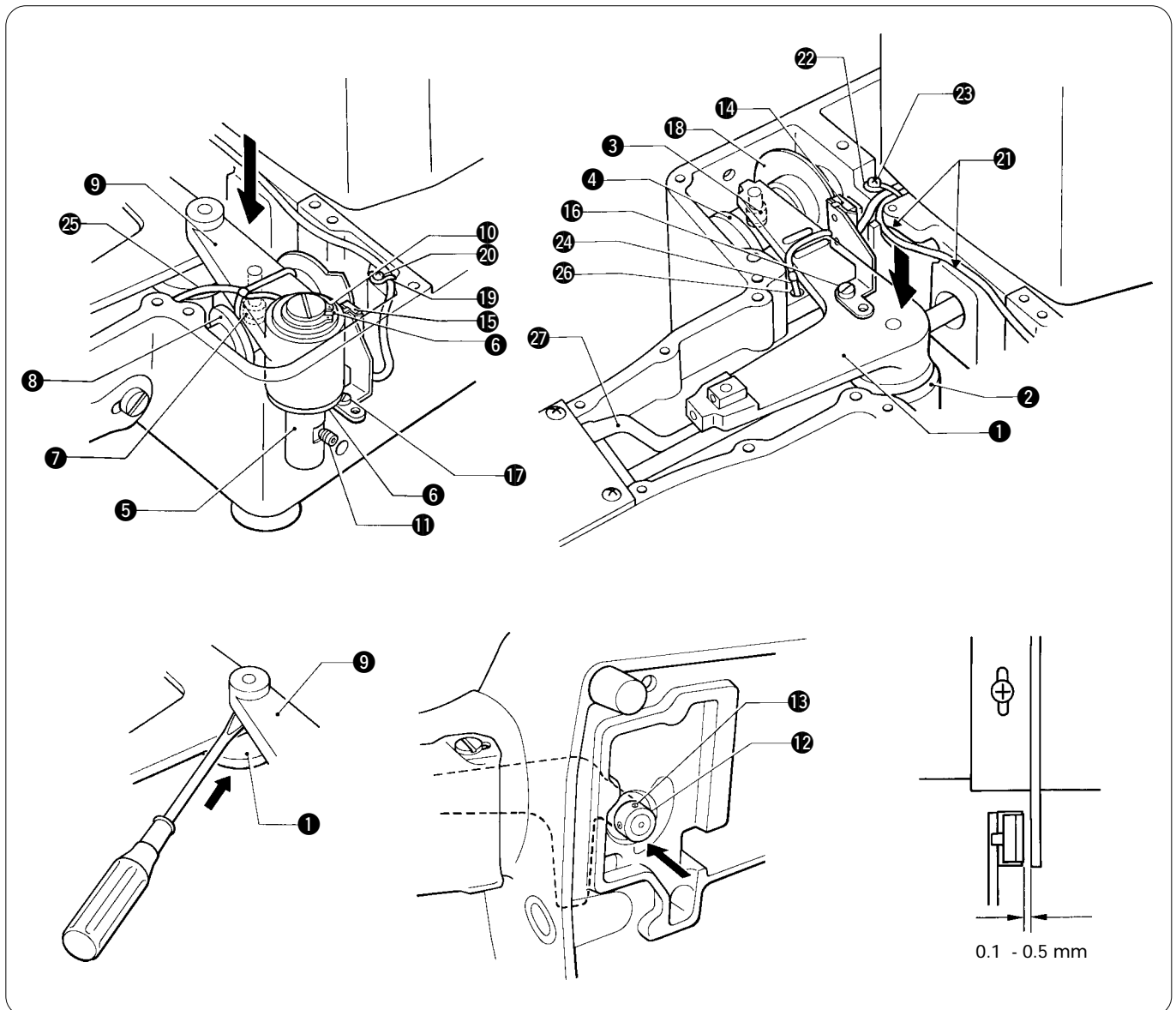

1. Pass the shaft of the X feed lever **1** through the bush **2**, and fit the feed cam roller **3** into the groove of feed cam X.
2. Place the washer **6** on the bearing surface which is inside the machine and passes the tack width lever shaft **5** through it. Place the Y feed lever **9** on the washer **6**, and fit the feed cam roller **7** into the groove of the Y feed cam **8**. Then, pass the tack width lever shaft **5** with the retaining ring **10** and the washer **6** on it, through the holes of the Y feed lever **9** and the hole in the machine.
3. Press the tack width lever shaft **5** downward, and adjust it so as to tighten the set screw **11** on the screw flat.
* Pay attention to the weight of the Y feed lever.
4. Put the driver into the end of the Y feed lever **9**, and press the X feed lever **1** downward.
5. Tilt the machine head until it stops.
6. Place the set screw collar **12** on the shaft of the X feed lever **1**, press it in the direction of the arrow, and tighten the set screw **13**.
7. Return the machine head to its original position.
8. Attach the X home position sensor **14** and the Y home position sensor **15** using the screws **16** and **17** so that the clearance between each home position sensor and the home position dog **18** is 0.1 - 0.5 mm.
9. Fix the cord of the Y home position sensor **15** using the cord support **19** and the screw **20**.
10. Tuck the cord of the Y home position sensor **15** into the recess **21** of the machine, and fix it along with the cord of the X home position sensor **14** using the cord support **22** and the screw **23**.
11. Insert the wicks **24** and **25** of the X feed lever **1** and the Y feed lever **9** into the hole **26** for lubrication.
* Do not allow the wicks to make contact with the connecting rod lever **27**.

5. ASSEMBLY

5-7. Upper shaft mechanism

During assembly, apply grease to the portions indicated by the white arrows.

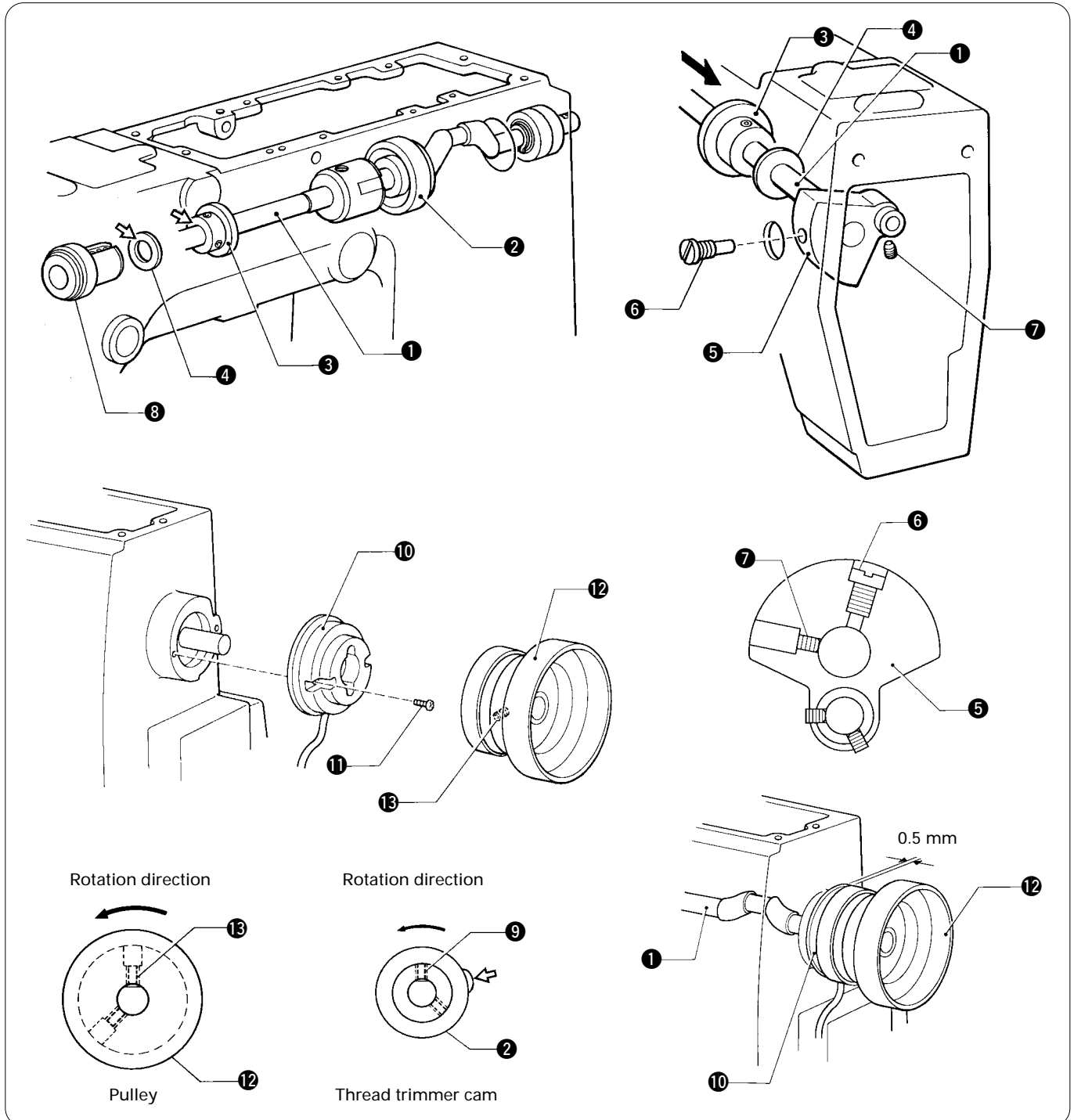

1. Insert the upper shaft **1** from the rear of the machine, and place the thread trimmer cam **2**, the bobbin winder pulley **3** and the washer **4** on the shaft.
* Apply adhesive (equivalent of Three Bond 1401) around the area which the bearing in the machine goes into. Also, apply grease to grooves on the thread trimmer cam **2**.
2. Pass the thread take-up crank **5** from the face plate side over the upper shaft **1**, and tighten the screw **6** and the set screw **7**.
3. Bring the thread take-up crank **5**, the washer **4** and the bobbin winder pulley **3** close to the upper shaft bush so that there is no end play in the upper shaft **1**. Secure the bobbin winder pulley **3** by adjusting the set screw to its screw flat and tightening it.
4. Press the thread trimmer cam **2** against the crank of the upper shaft **1**. Adjust the set screw **9** that comes first when rotating to the screw flat, and tighten it.
5. Attach the synchronizer **10** to the machine using the screw **11**.
6. Attach the pulley **12** leaving a 0.5 mm clearance from the protrusion of the synchronizer **10**, tighten the set screw **13** that comes later when rotating to the screw flat.

5-8. Needle bar mechanism

During assembly, apply grease to the portions indicated by the white arrows.

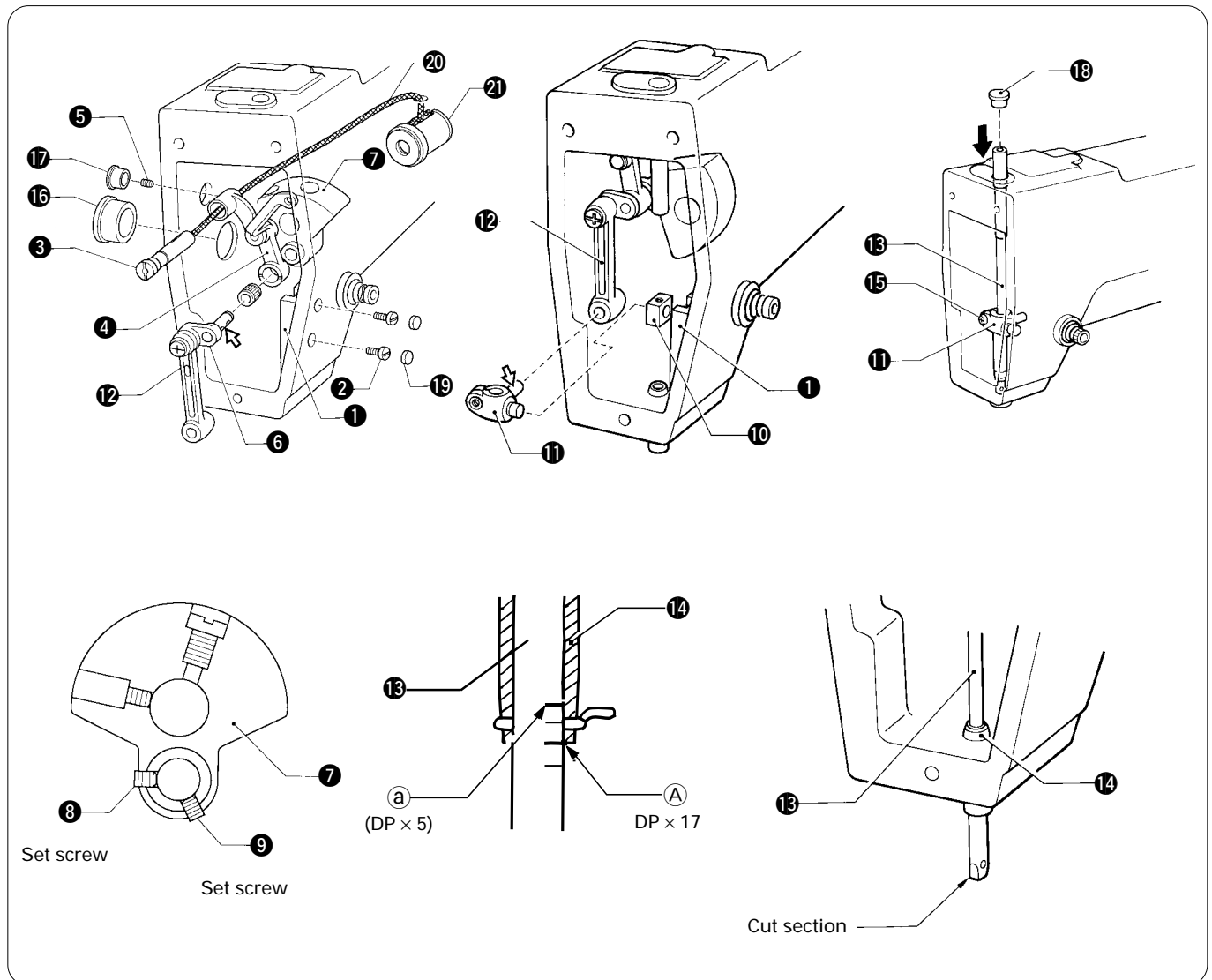

1. Temporarily tighten the screw ② of the needle bar guide ①.
2. Pass the thread take-up support stud ③ through the thread take-up assembly ④, lightly press the former, and secure them using the set screw ⑤.
3. Pass the needle bar crank ⑥ through the thread take-up assembly ④ and the counter crank ⑦, adjust the set screw ⑧ to the screw flat, and tighten the set screws ⑧ and ⑨.
4. Fit the chamfering side of the needle bar guide slide block ⑩ into the groove on the needle bar guide ①, and insert the shafts of the needle bar clamp ⑪ into the thread take-up lever ⑫ and the needle bar guide slide block ⑩, as shown in the figure.
* Be sure to apply grease to the sliding block ⑩ and the groove of the needle bar guide ①.
5. Insert the needle bar ⑬ from the top of the machine into the needle bar clamp ⑪.
6. Turn the pulley to set the needle bar ⑬ at its lowest position. Move the needle bar vertically so as to align the second lowest reference line ① (for using needle DP × 17) or the highest reference line ② (for using needle DP × 5) on the needle bar ⑬ with the lower end of needle bar bush (D) ⑭. Tighten the screw ⑮ with the cut section of the needle bar facing the front.
7. Find the position of the needle bar guide ① so that the pulley rotates easily, and tighten the screw ②.
8. Attach the oil cap ⑯ and the rubber caps ⑰, ⑱, and ⑲.
9. Insert the wick ⑳ extending from the thread take-up support stud ③ into the lubrication hole ㉑.

5-9. Lower shaft mechanism

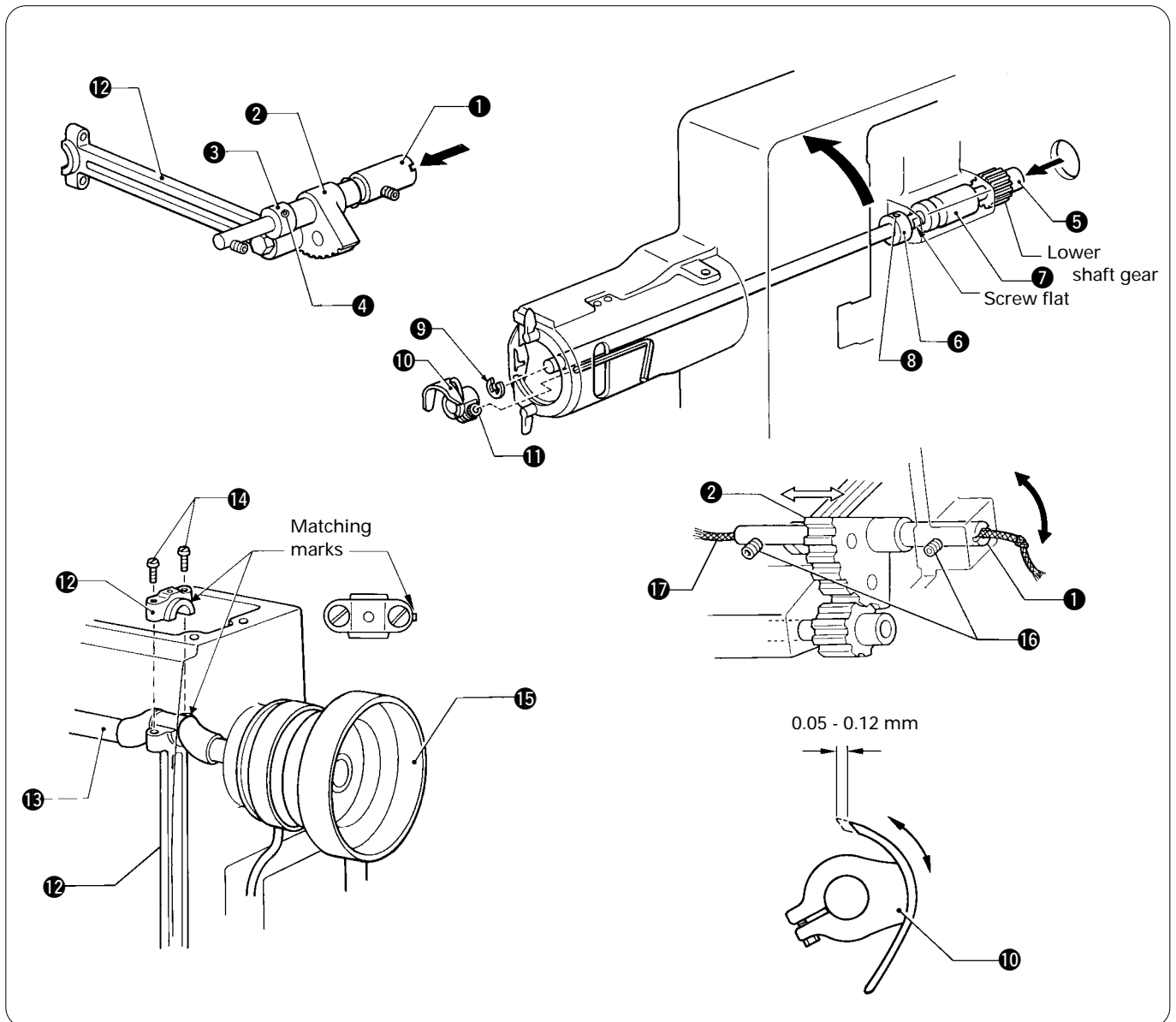

1. Tilt the machine head until it stops.
2. Insert the rock gear shaft **1** from the rear of the machine, pass the rock gear **2**, the set screw collar **3** over the shaft, bring them close together without any clearance, and tighten the set screw **4**.
3. Insert the lower shaft **5** from the rear of the machine, pass the set screw collar **6** over it, and engage the lower shaft gear with the rock gear **2**.

NOTE:

When inserting the lower shaft **5** from the rear into the machine, lower the needle bar to its lowest position, and position the screw flat of the lower shaft so that it faces down. Also, apply grease to the shuttle race base and the lower shaft bush **7** at this time.

4. Sandwich the lower shaft bush **7** between the lower shaft gear and the set screw collar **6** without any clearance, and tighten the set screw **8**.
* Apply grease to the portion between the lower shaft bush **7** and the set screw collar **6**.
5. Fit the retaining ring **9** on the lower shaft **5**, press the driver **10** against the retaining ring **9**, and tighten the screw **11**.
6. Return the machine head to its original position.
7. Fit the crank rod **12** over the crank of the upper shaft **13**, align the matching mark of the crank rod **12** with that of the upper shaft **13**, and tighten the screw **14**.
* Apply grease to the engagement portion between the upper shaft crank and the crank rod.
8. Tilt the machine head until it stops.
9. Turn the pulley **15** to move the rock gear **2** right and left until the pulley rotates easily. Turn the rock gear shaft **1** to allow 0.05 - 0.12 mm play of the driver **10**.
10. Pass the wick **17** through the rock gear shaft **1**, and knot it on the end.
11. Return the machine head to its original position.

5-10. Thread trimmer mechanism (2)

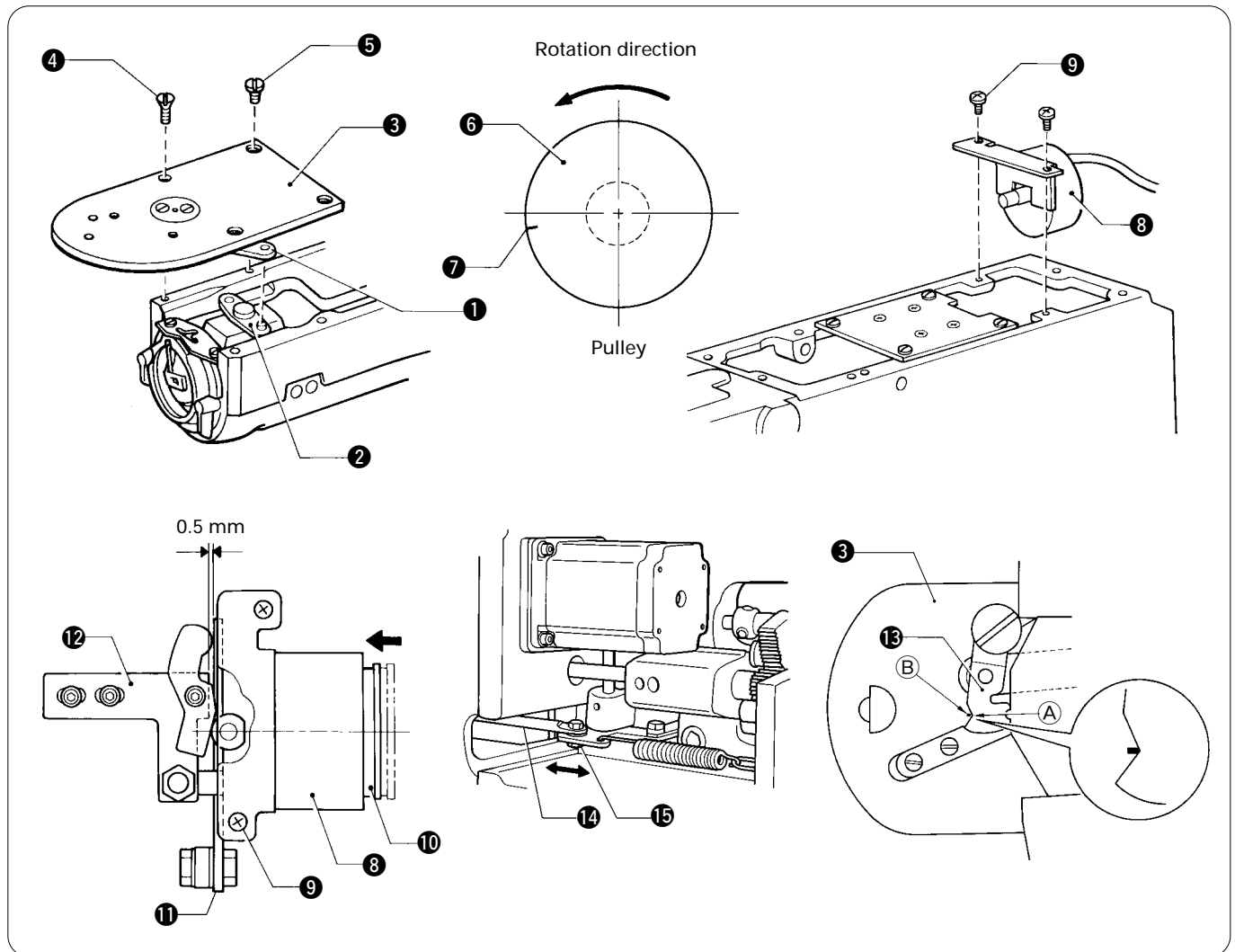

1. Fit the hole of the thread trimmer connecting rod ① over the pin of the connecting lever ②. Secure the needle plate ③ using the screws ④ and ⑤ so that the hole on the needle plate is centered at the needle position.
2. Turn the pulley ⑥ until the mark ⑦ has slightly passed over the horizontal line.
* Adjust the position of the pulley to the position where the cam grooves on the thread trimmer cam do not fluctuate.
3. Attach the thread trimming solenoid ⑧ using the screw ⑨. At this time, the plunger ⑩ of the thread trimming solenoid ⑧ must be fully pressed (the same status as when the thread trimming solenoid ⑧ is turned on), and a 0.5 mm clearance must be provided between the thread trimmer driving lever ⑪ and the driving lever stopper ⑫.
4. Make sure that the thread trimmer driving lever ⑪ moves smoothly when the plunger ⑩ is pressed and released.
5. Tilt the machine head until it stops.
6. Loosen the nut ⑭ and move the connecting rod lever ⑮ to the left or right to adjust so that the V section ① is aligned with the index mark ② on the needle plate when the sewing machine in the stopped position and the movable knife ⑬ is moved toward the index mark.
7. Return the machine head to its original position.

5-11. Thread wiper mechanism (2)

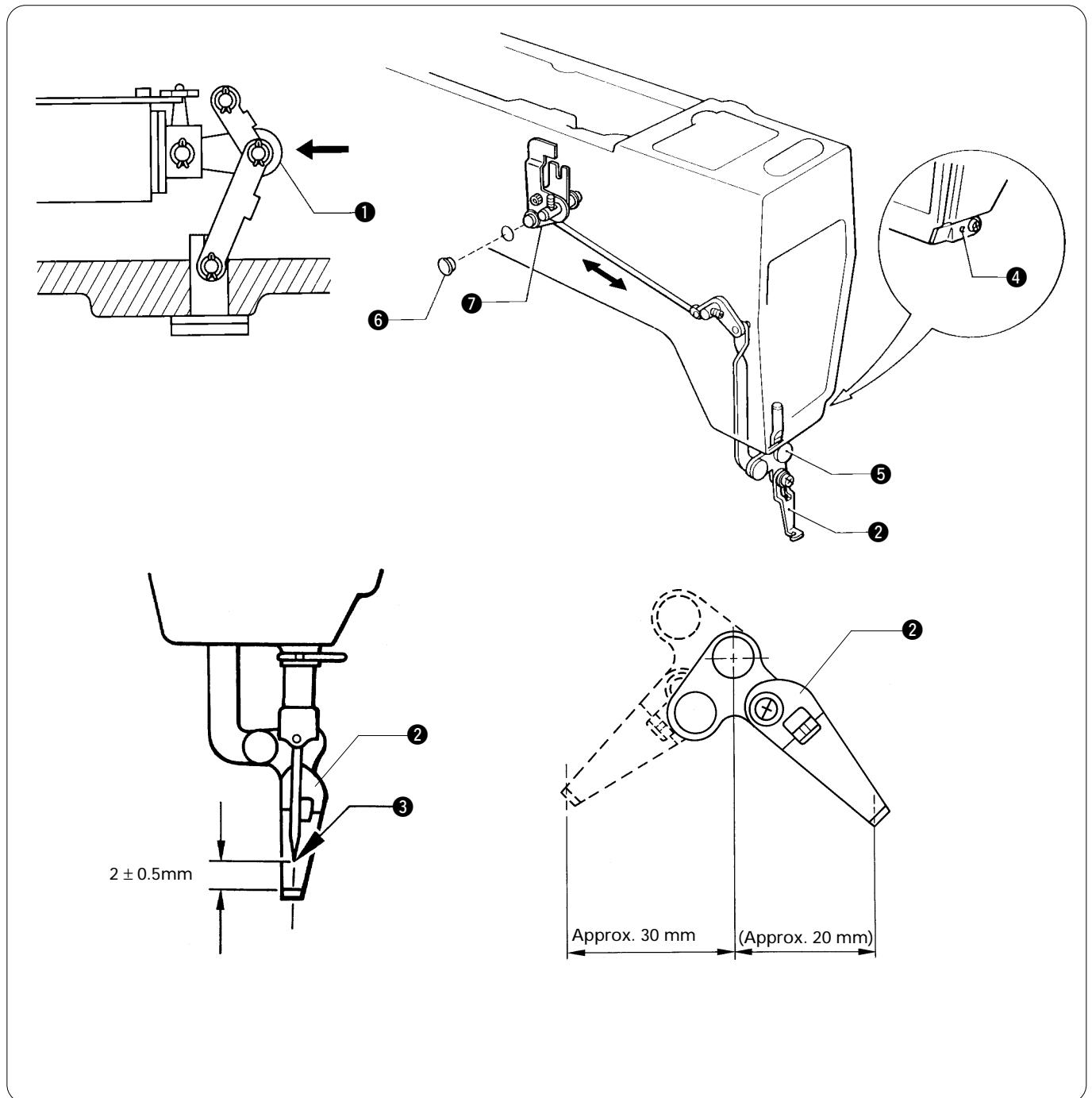

1. When the sewing machine in the stop position, press link C **1** to check that the clearance between the top of the thread wiper and the needle point **3** is 2 ± 0.5 mm when the thread wiper **2** has passed under the needle.
If it is not, loosen the set screw **4**, and adjust the thread wiper arm **5** by moving it vertically.
2. Make sure that the thread wiper **2** is positioned 30 mm to the left from the center of the needle bar when link C **1** is fully pressed.
If it is not, remove the rubber cap **6**, loosen the set screw **7**, and adjust the thread wiper position.

5-12. Shuttle race mechanism

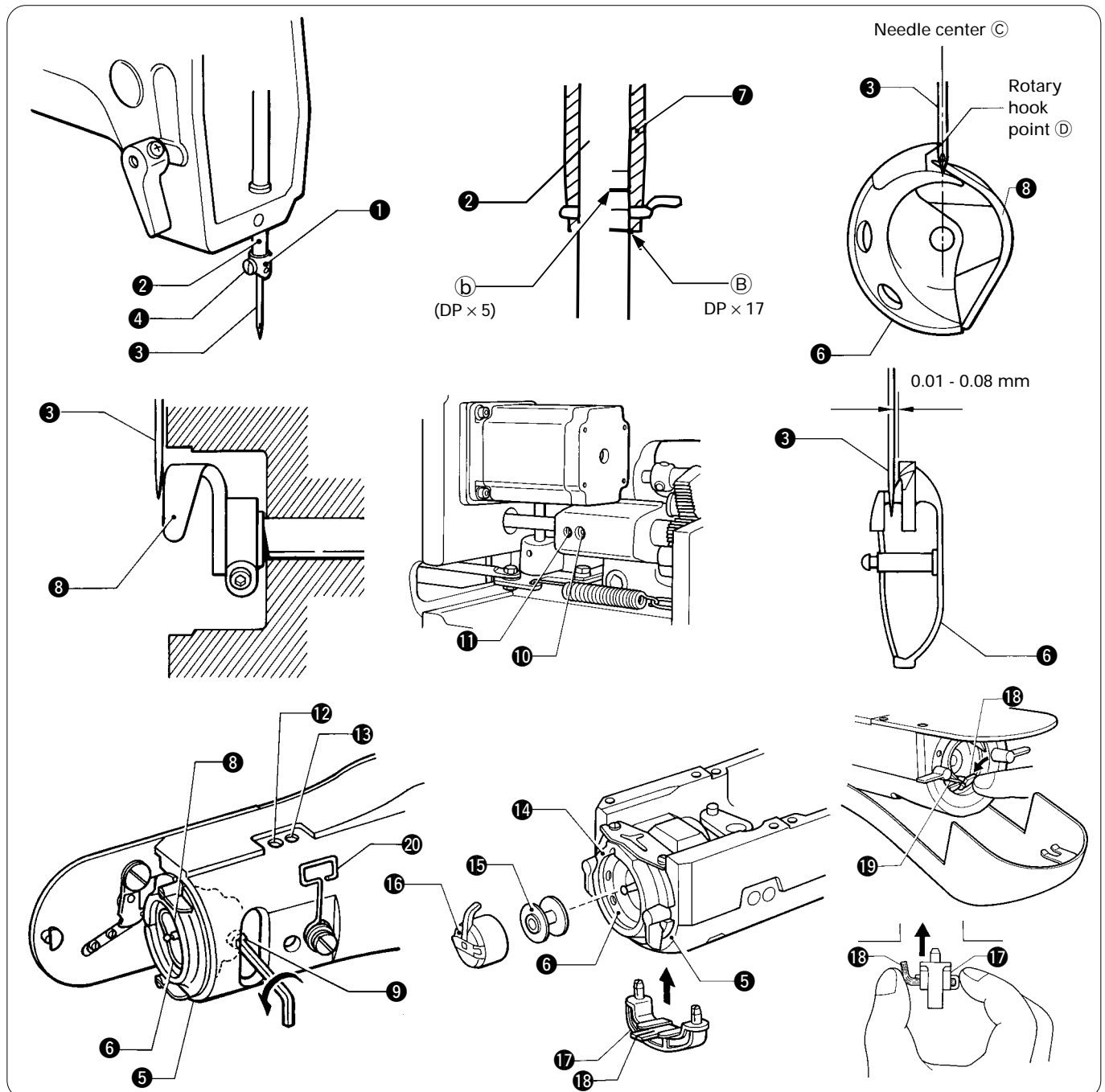

1. Attach the needle bar thread guide **1** to the needle bar **2**, and attach the needle **3** (DP × 5 for knitwear, DP × 17 for denim) with its long groove facing the front, using the set screw **4**.
2. Fit the inner rotary hook **6** in the shuttle race base **5**. Turn the pulley to raise the needle bar **2** from its lowest position until the lowest reference line **B** (for DP × 17 needle; use the second lowest reference line **b** for DP × 5 needle) is aligned with the bottom of needle bar bush **D** **7**. Loosen the screw **9**, and move the driver **8** to align the center of the needle **C** with the inner rotary hook point **D**.
3. Make sure that the needle **3** just makes contact with the needle guard of the driver **8** when the center **C** of the needle is aligned with the point of the inner rotary hook. If it does not, loosen the set screw **10**, and turn the eccentric shaft **11**. Retighten the set screw **10** afterwards.
4. Make sure that there is a 0.01 - 0.08 mm clearance between the needle **3** and the point **D** of the inner rotary hook when they are aligned. If there is not, loosen the set screw **12**, and turn the eccentric shaft **13**. Retighten the set screw **12** afterwards.
5. Attach the large shuttle hook **14** to the shuttle race base **5**, insert the bobbin **15** into the bobbin case **16**, and fit them in the inner rotary hook **6**.
6. Attach the felt support **17** to the shuttle race base **5**.
 - * Place it as shown in the illustration so as not to clamp the felt **18**, and then gently press the felt **18** and the wick **19** until they are at the same height as the rotary hook race.
 - * Return the support **20** to its original position.

5-13. Presser arm mechanism

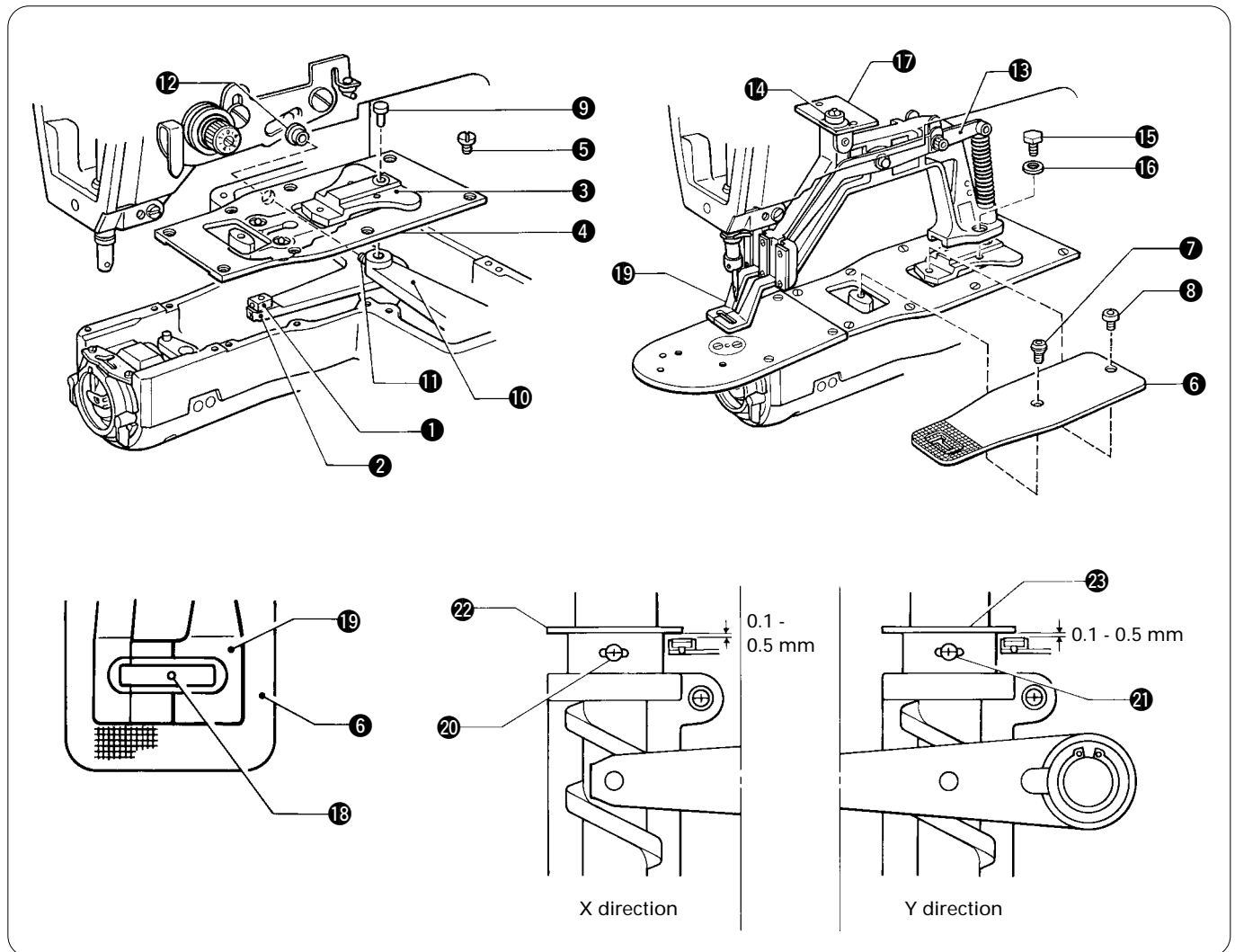

1. Place the slide block **1** on the pin of the X feed lever **2**, fit the feed bracket **3** into the feed bar guide plate **4** with care not to drop the ball bearing, pass the slide block **1** through the slot in the feed bracket **3**, and secure the feed bar guide plate **4** using the screw **5**.
2. Attach the feed plate **6** using the flat **7** and the screw **8**.
3. Pass the tack width feed shaft **9** through the hole in the feed bracket **3** and the hole of the Y feed lever **10**, adjust the former to the screw flat, and press the tack width feed shaft **9** from above to secure it using the set screw **11**.
4. Attach the rubber cap **12**.
5. With attention not to let the bearing balls in the presser arm support shaft **14** fall, fit the presser arm **13** to the protrusion of the feed bracket **3**, and secure the presser arm **13** to the feed bracket **3** using the bolt **15** and the washer **16**.
6. Secure the presser arm support shaft **14** using the set screws so that the back of the support plate **17** can just make contact with ball bearings in the presser arm support shaft **14** when the work clamp rises.
7. Turn on the power of the machine, set the program to No.00, press the foot switch to reset X and Y to original position.
8. Make sure that the slot **18** is centered in the work clamp **19** and the feed plate **6**.
If it is not, loosen the flat screw **7** and the screw **8** of the feed plate **6** and the bolt **15** of the presser arm **13**, and adjust the position of the slot **18**.
If it still is not centered turn off the power, loosen the screws **20** and **21**, and turn the feed home position dogs **22** and **23** little by little. Then tighten the screws **20** and **21**, and perform **7** for positioning.
* At this time, the clearance between the feed home position dog and the sensor sensing surface should be 0.1 - 0.5 mm.
9. After adjustment is completed, turn off the power.

5-14. Covers

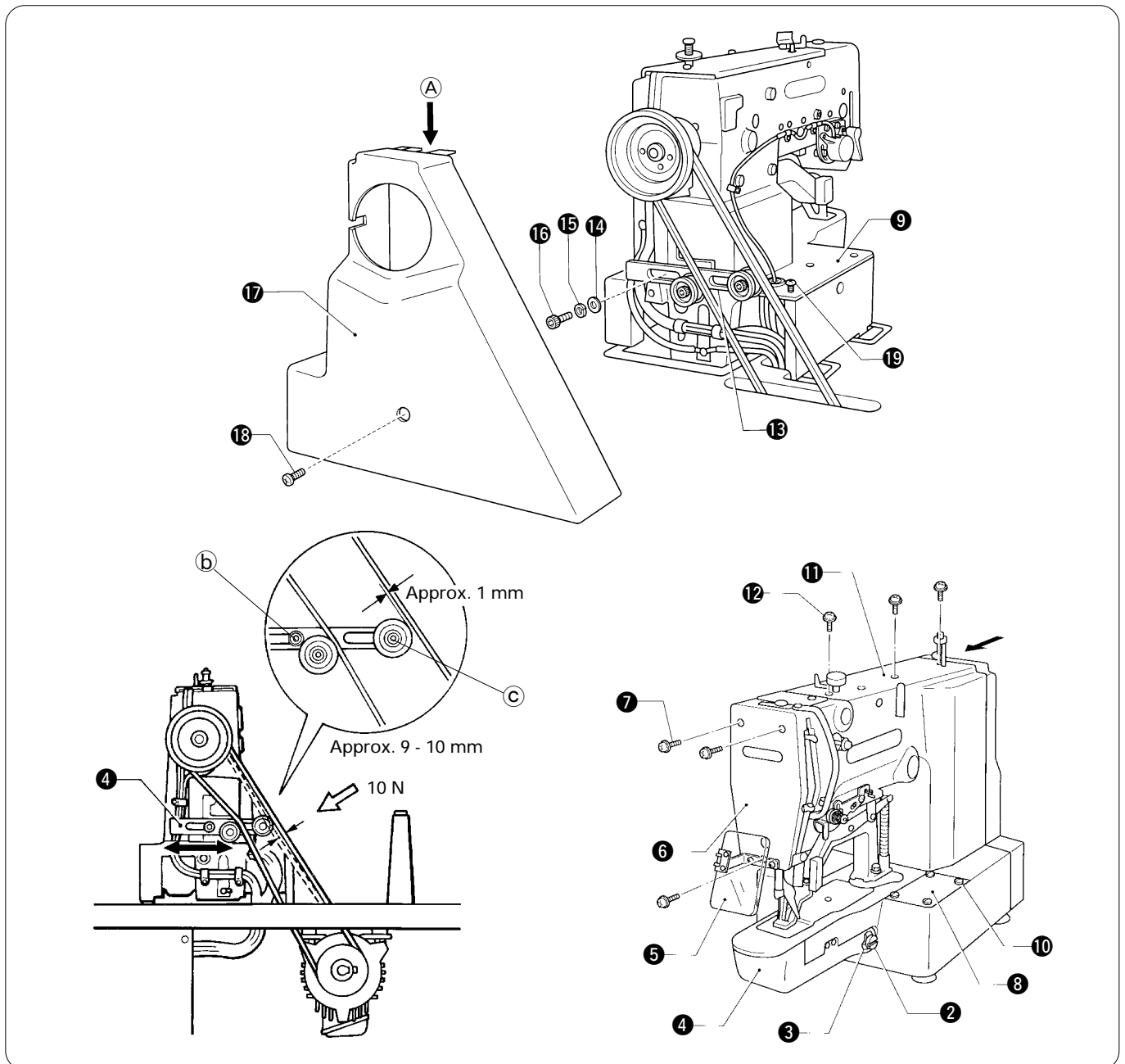

1. Attach the V belt ①.
2. Attach the the shuttle race cover ④ using the shoulder screw ② and the washer ③.
3. Attach the eye guard ⑤ and the face plate ⑥ using the screws ⑦.
4. Attach bed covers (R) ⑧ and (L) ⑨ using the screws ⑩.
5. Temporarily attach the top cover ⑪ using the screw ⑫.
6. Provisionally install the tension pulley ⑬ with the flat washer ⑭, spring washer ⑮ and bolt ⑯.
 - * Adjust the belt tension by moving the tension pulley to the right and left so that there is 9 - 10 mm of deflection in the V-belt ① when it is gently pushed in the middle with a force of approximately 10 N.
 - * After adjusting, tighten the bolt (b) to secure the left pulley assembly. Move the right tension pulley so that there is a gap of about 1 mm between it and the V-belt ①, and then tighten the bolt (c) to secure the right pulley assembly.
7. Attach the belt cover ⑰ while inserting part (A) into the top cover ⑪, and tighten the screws ⑱ and ⑲.
8. While lightly pressing the top of the belt cover ⑰ in the direction of the arrow, tighten the screw ⑫.

6. ADJUSTMENT

⚠ CAUTION

- ⊘ Maintenance and inspection of the sewing machine should only be carried out by a qualified technician.
- ⚠ Turn off the power switch and disconnect the power cord from the wall socket at the following times, otherwise the machine may operate if the foot switch is depressed by mistake, possibly resulting in injury.
 - When carrying out inspection, adjustment, and maintenance
 - When replacing consumable parts such as the rotary hook and knife
- ⚠ If the power switch needs to be left on when carrying out some adjustment, be extremely careful to observe all safety precautions.
- ⚠ Use only the proper replacement parts specified by Brother.
- ⚠ If any safety devices have been removed, be absolutely sure to re-install them to their original positions and check that they operate correctly before using the machine.
- ⊘ Any problems in machine operation which result from unauthorized modifications to the machine will not be covered by the warranty.

6-1. Adjusting the needle bar height



Turn the pulley to lower the needle bar at its lowest position. Remove the rubber cap ②, and loosen the screw ③. Move the needle bar up or down to adjust the needle bar height so that the second lowest line ① of the needle bar is aligned with the bottom of the needle bar bush ① when the needle bar is lowered to its lowest position.

* For needle DP × 5, align the highest line ① on it with the bottom of the needle bar bush.

6-2. Adjusting the needle bar lift stroke

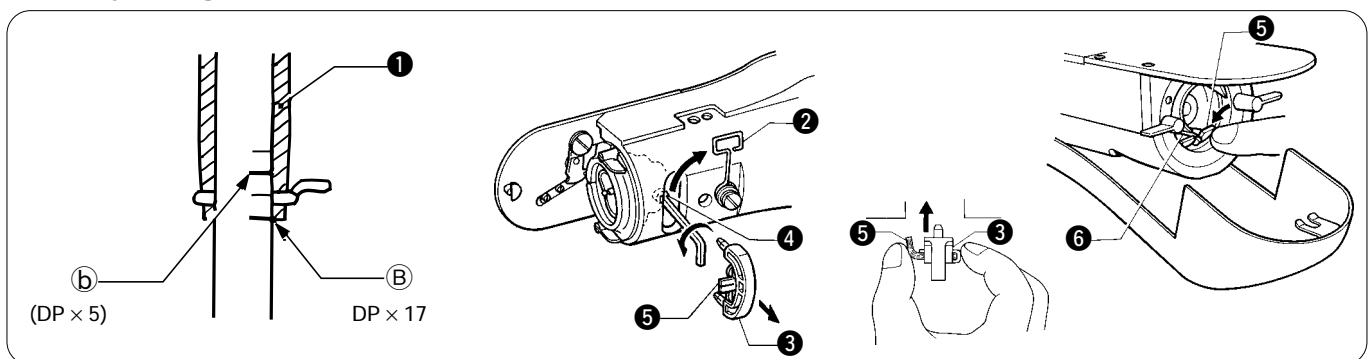

Turn the machine pulley to raise the needle bar from the lowest position until the lowest reference line on the needle (reference line ①) is aligned with the lower edge of the needle bar bush ①.

* If using a DP × 5 needle, use the second reference line from the top of the needle (reference line ①).

1. Open the support ② in the direction of the arrow, and remove the felt support ③.
2. Loosen the screw ④, and move the driver to adjust so that the tip of the rotary hook is aligned with the needle center line.

* When returning the felt support ③, place it as shown in the illustration so as not to clamp the felt ⑤, and then gently press the felt ⑤ and the wick ⑥ until they are at the same height as the rotary hook race.

* Return the support ② to its original position.

6-3. Adjusting the driver needle guard

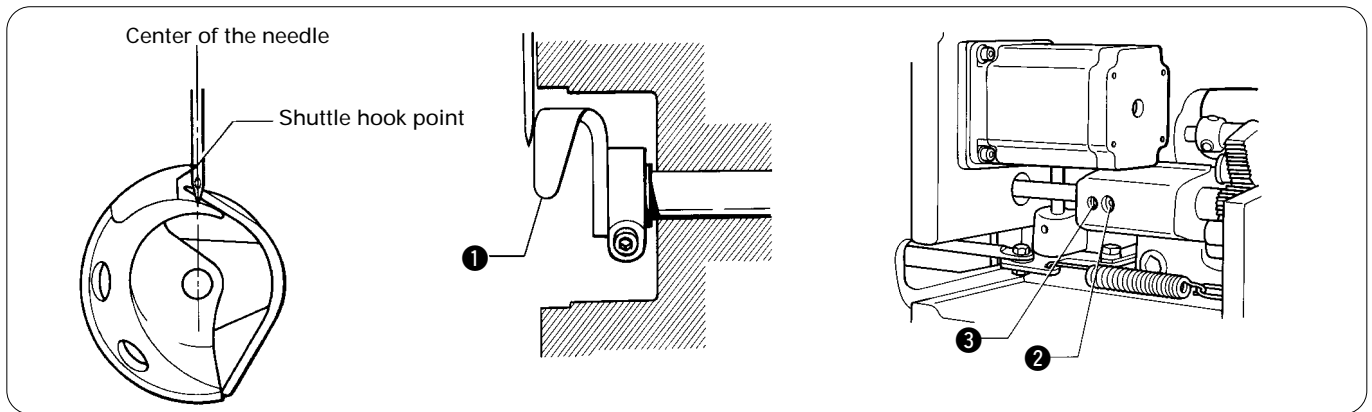

Turn the pulley to align the shuttle hook point with the center of the needle. Loosen the set screw **2**, and turn the eccentric shaft **3** to adjust the position of the driver needle guard **1** so that it makes contact with the needle.

If the needle contact pressure is too great, skipped stitches may result. On the other hand, if the driver needle guard **1** is not touching the needle, the inner rotary hook point will obstruct the needle, resulting in an excessively high amount of friction.

6-4. Adjusting the needle clearance

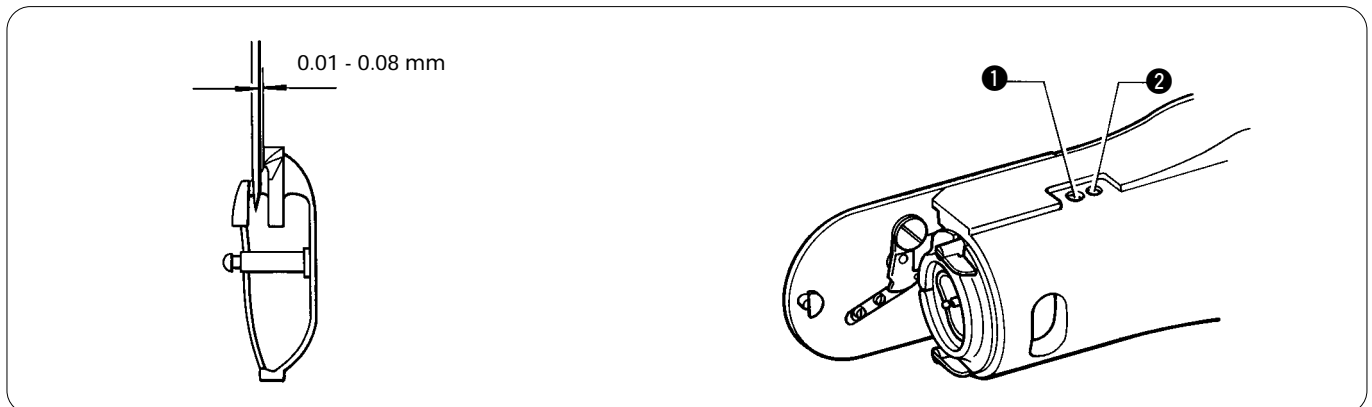

Turn the pulley to align the shuttle hook point with the center of the needle. Loosen the set screw **1**, and turn the eccentric shaft **2** to adjust the clearance between the needle and the shuttle hook point to 0.01 - 0.08 mm.

6-5. Adjusting the shuttle race thread guide

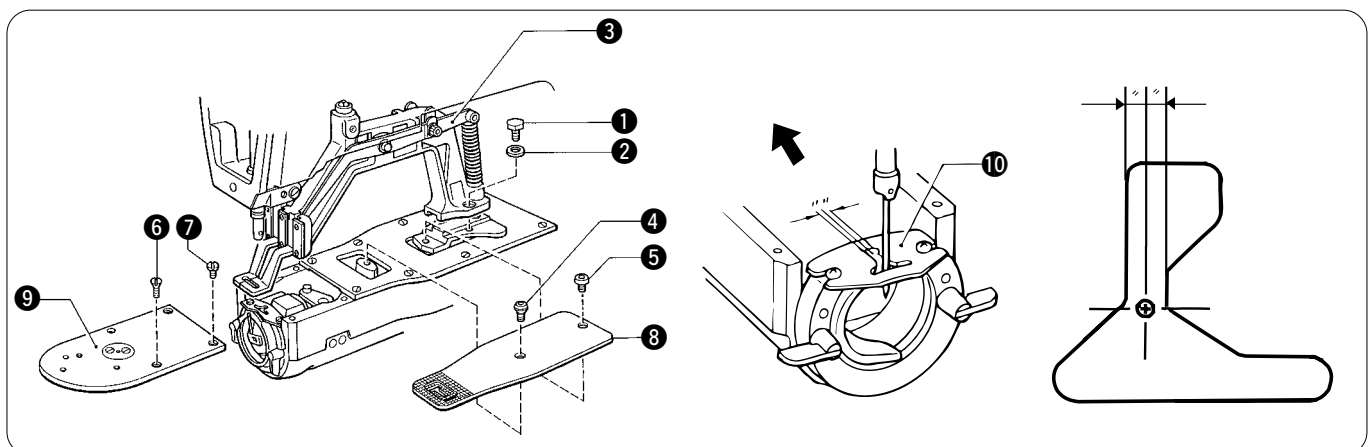

- Loosen the bolt **1** and the washer **2**, and remove the presser arm **3**. Then loosen the two flat screws **4** and **6**, and the screws **5** and **7**, and remove the feed plate **8** and the needle plate **9**.
* Pay attention not to let the ball bearing of the presser arm support shaft fall.
- While pushing the shuttle race thread guide **10** in the direction of the arrow, adjust the position of the shuttle race thread guide **10** so that the needle is central in the needle groove of the shuttle race thread guide **10**.

6. ADJUSTMENT

6-6. Adjusting the work clamp lift amount

The maximum work clamp lift amount is 17 mm from the top of the needle plate.

The lift amount for each model is adjusted as shown in the table at the time of shipment.

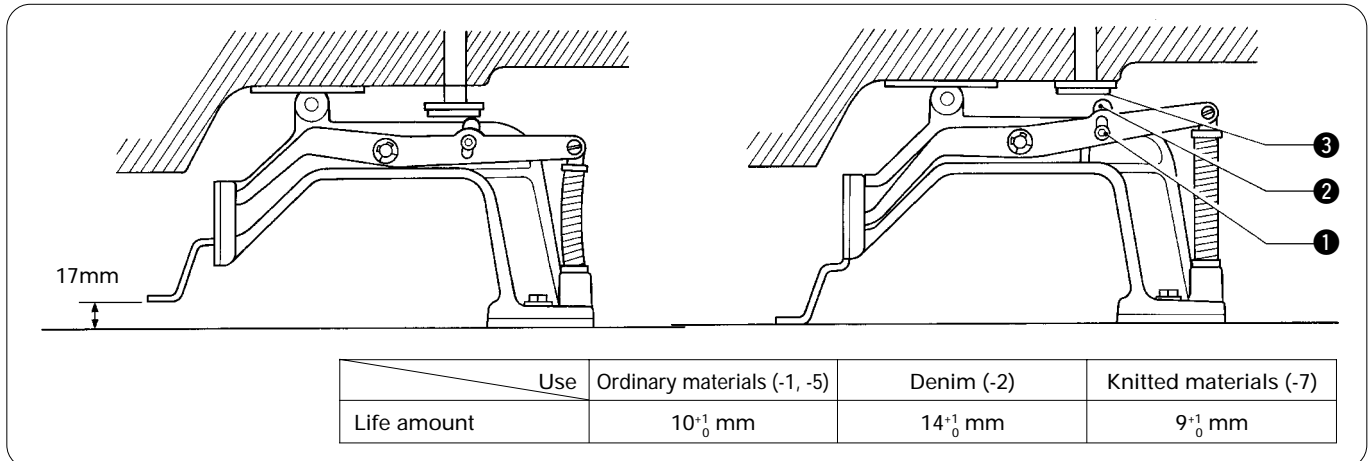

- To adjust the work clamp lift amount, loosen the bolt ① and move the presser arm lever plate ② up or down.
- Apply grease to the bottom of the presser plate ③ to the top of the presser arm lever plate ② and to the sliding part of the work clamp (grease is already applied at the time of shipment), and check that the movement becomes easier.
- Check that there is a gap between the presser arm lever plate ② and the presser plate ③ when the presser foot is lowered.
 - * If movement is sluggish when the work clamp is being raised and lowered, it may not be possible to increase the work clamp life amount.
 - * If the work clamp cannot be raised or lowered, error code "E-61" or "E-63" will be displayed.

6-7. Adjusting the thread wiper

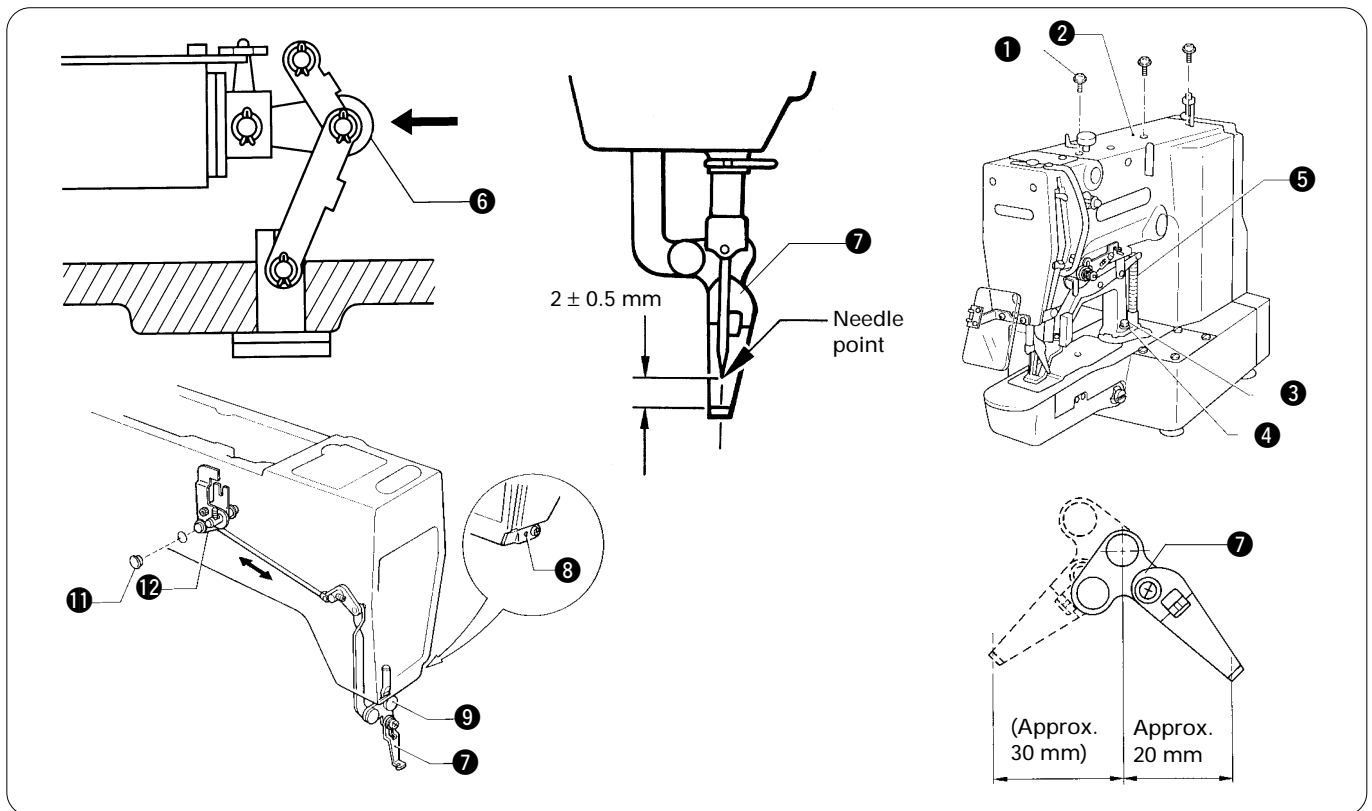

- Loosen the screw ①, and remove the top cover ②.
- Remove the bolt ③, the washer ④, and the presser arm ⑤.
- When the sewing machine in the stop position, press link C ⑥ to pass the thread wiper ⑦ under the needle. Loosen the set screw ⑧, and move the thread wiper arm ⑨ up and down to adjust the clearance between the top of the thread wiper and the needle point is 2 ± 0.5 mm.
- Remove the rubber cap ⑪, and loosen the set screw ⑫ to adjust the position of the thread wiper so that it is positioned to the right approximately 20 mm from the center of the needle bar.

6-8. Adjusting the thread take-up amount

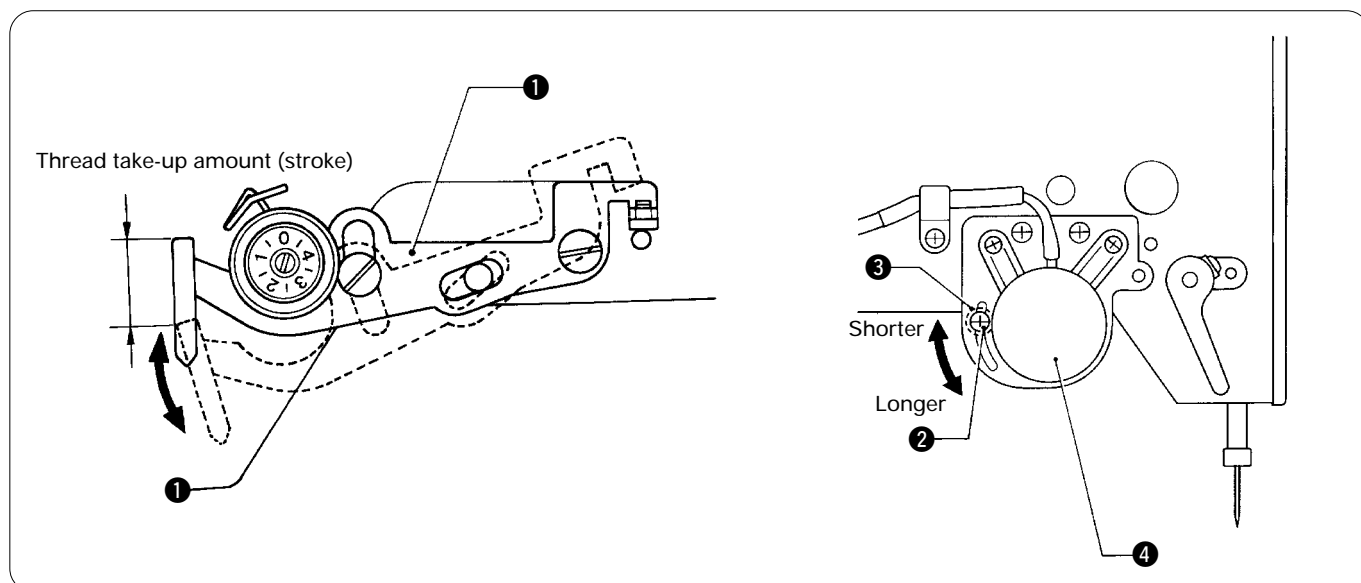

At the time of shipment from the factory, the thread take-up amount (stroke) of the thread take-up lever ① is set to the standard setting of 5 mm for ordinary material (-1/-5) ordinary material specifications, and 0 mm for knitted material specifications. You may need to adjust this setting depending on the sewing conditions to prevent the thread from pulling out at the sewing start.

[Adjustment method]

Loosen the screw ② and move the stopper (3.57 nut) ③ to adjust the operating angle of the thread take-up solenoid ④.

* The stroke of the thread take-up lever becomes longer when the stopper is moved downward, and it becomes shorter when the stopper is moved upward.

NOTE:

Do not increase the stroke of the thread take-up lever any more than is necessary.

If the sub-thread tension is too high, the needle thread length may become too short and the thread may come out of the needle. Furthermore, if the sub-thread tension is too weak, the needle thread length may become too long and the underside of the article being sewn may become untidy.

6-9. Adjusting the movable knife

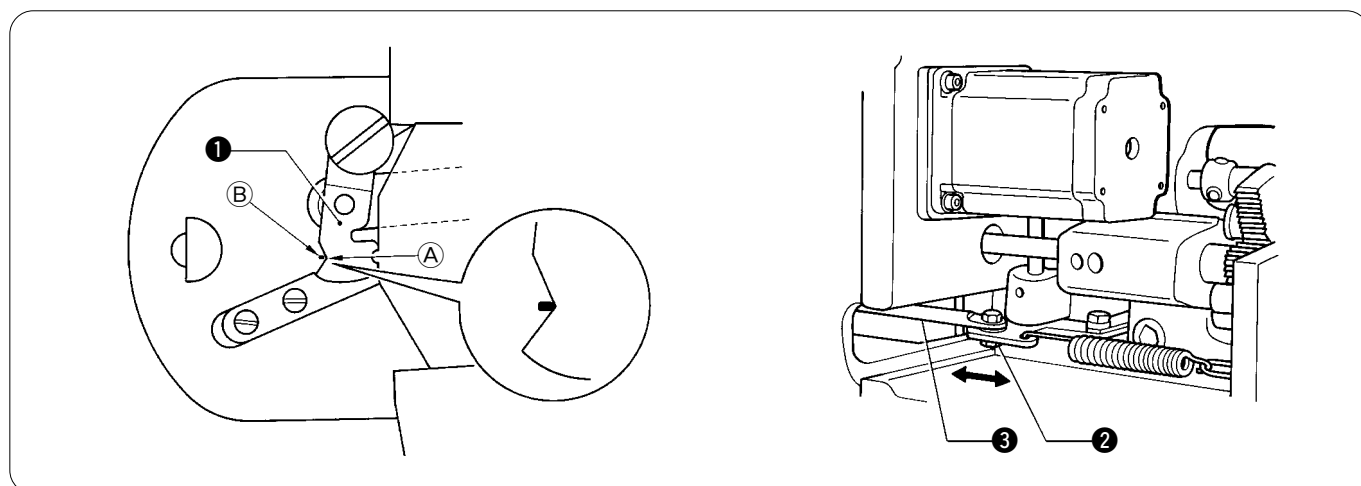

Loosen the nut ② and move the connecting rod lever ③ to the left or right to adjust so that the V section ① is aligned with the index mark ② on the needle plate when the sewing machine in the stopped position and the movable knife ① is moved toward the index mark.

6. ADJUSTMENT

6-9-1. Replacing the movable and fixed knives

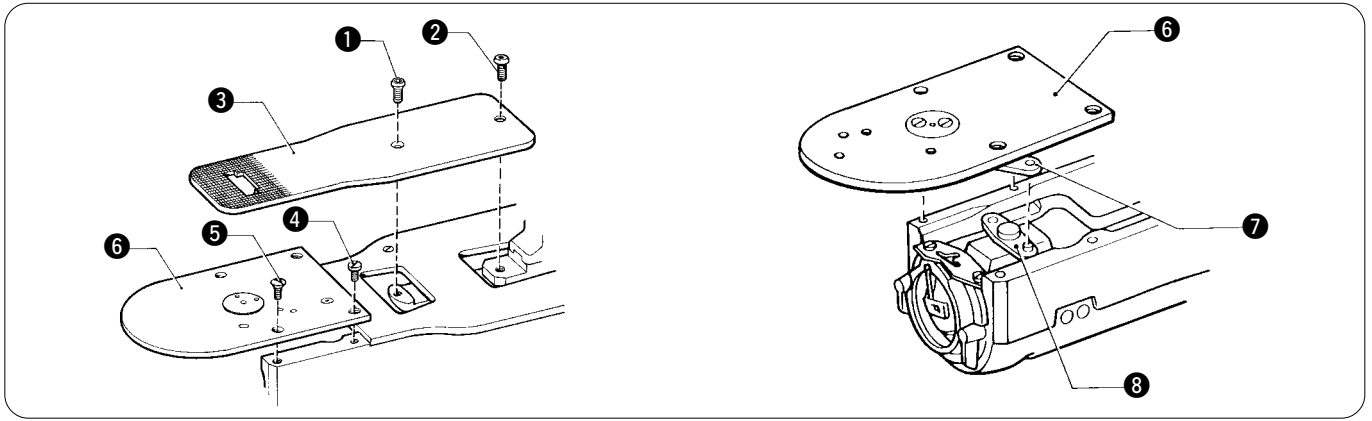

1. Open the shuttle race cover, and remove the flat screw ①, the screw ② and the feed plate ③.
2. Remove the two screws ④ and the two flat screws ⑤, and needle plate ⑥.
3. Remove the thread trimmer connecting rod ⑦ from the pin of the connecting rod lever ⑧.

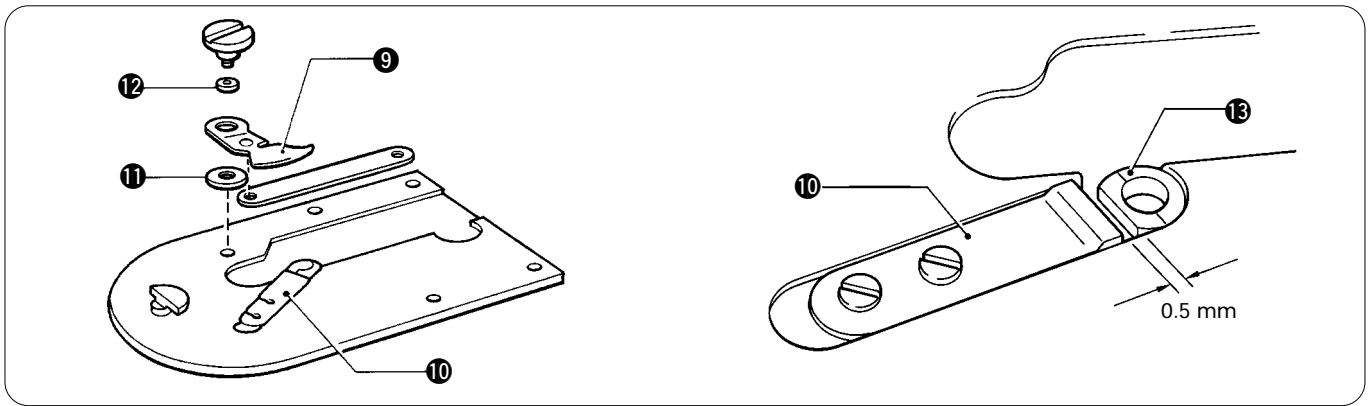

4. Remove the movable knife ⑨, and replace it with a new one. At this time, make sure that the movable knife ⑨ and the fixed knife ⑩ cut the thread cleanly. If necessary, replace the washer ⑪ to obtain a clean cut.
*Apply grease to the outside of the collar ⑫ at this time.
5. Remove the fixed knife ⑩, and replace it with a new one. Place it 0.5 mm from the needle hole plate ⑬.
6. Insert the thread trimmer connecting rod ⑦ to the pin of the connecting rod lever ⑧, and attach the needle plate ⑥.

6-9-2. Adjusting the engagement of the movable knife and fixed knife

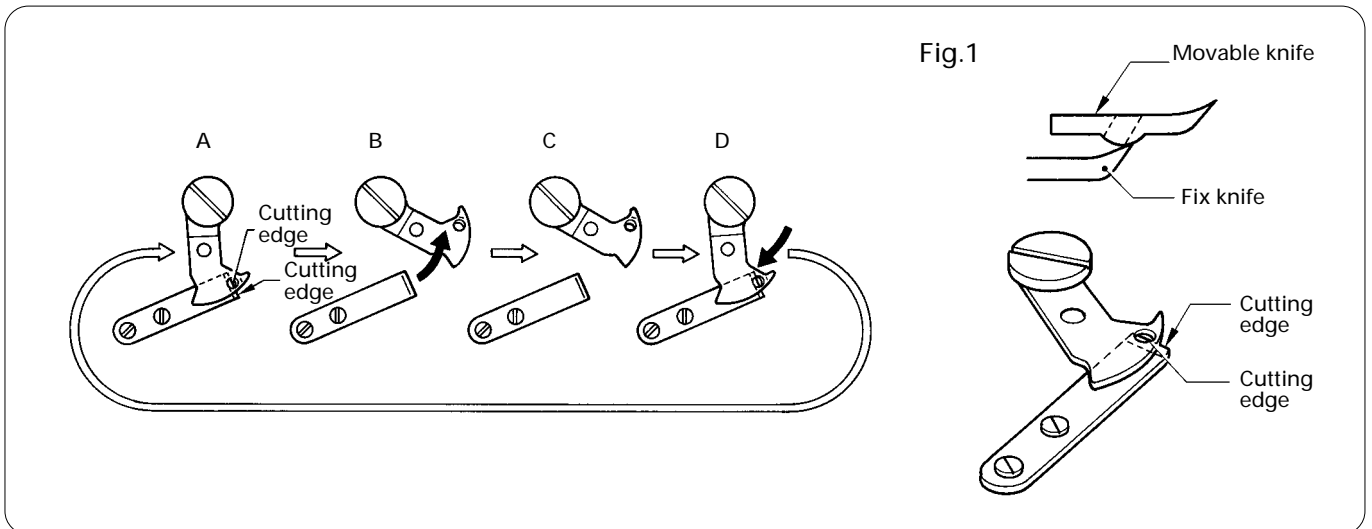

- A. After the movable knife and fixed knife are properly engaged, tighten the screw as shown in Fig.1.
 - B. Turn the movable knife (in the direction of the arrow) while the screw is still tightened.
 - C. Loosen the screw.
 - D. Turn the movable knife (in the direction of the arrow) while the screw is still loosened.
- Repeat above steps A, B, C and D four or five times to maintain the cutting performance of the knife.

6-10. Adjusting the driving lever stopper position

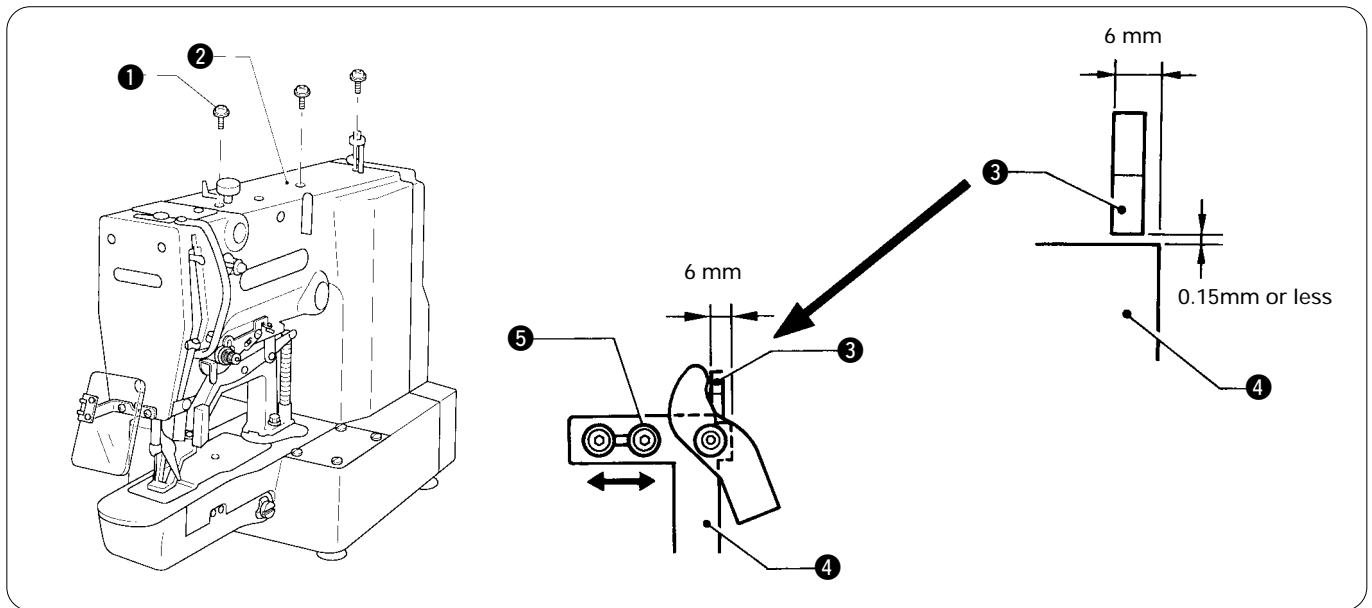

1. Remove the screw ① and the top cover ②.
 2. If thread trimming is not performed, loosen the screw ⑤ so that the difference between the thread trimmer driving lever ③ and the driving lever stopper ④ is 6 mm.
 - * Make sure that the clearance between the thread trimmer driving lever ③ and the driving lever stopper ④ is at the most 0.15 mm.
- The driving lever stopper ④ has an imprinted number mark: 2, 3, or 4. If the clearance is larger than 0.15 mm, replace the driving lever stopper ④ with that with a different number. For example, when the number 3 stopper is used, replace it with number 4 stopper. When the number 4 stopper is used, replace it with number 2 stopper.

6-11. Adjusting the thread trimmer driving lever position

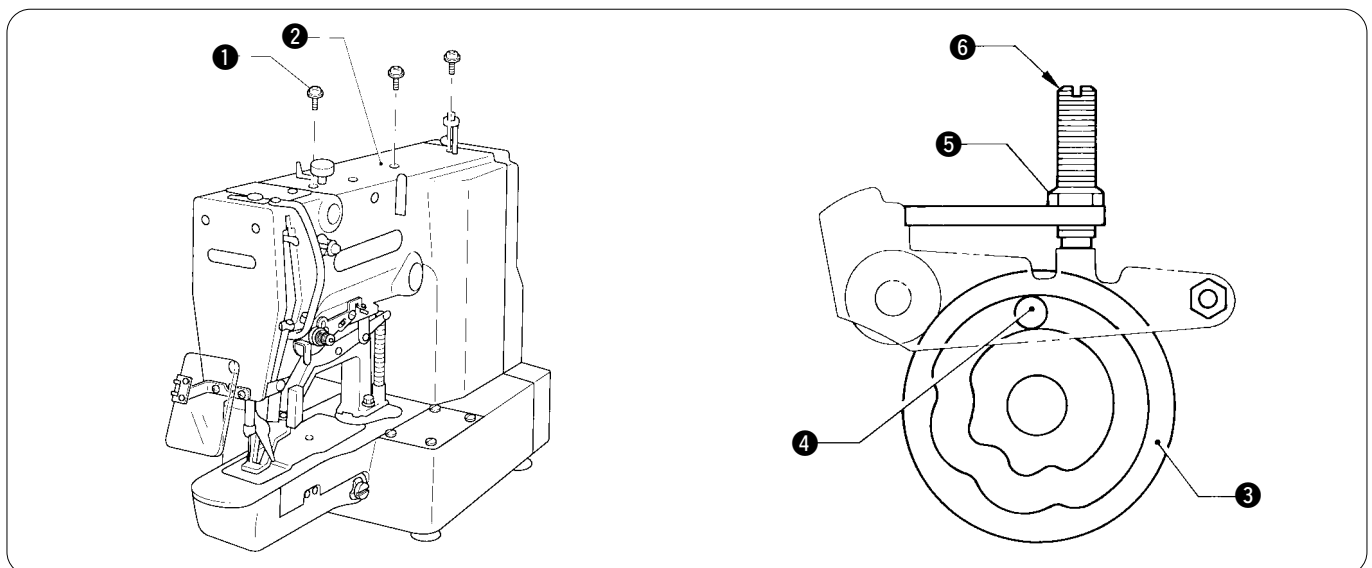

1. Remove the screws ① and the top cover ②.
2. Turn the pulley to place the thread trimmer cam ③ with its non-operating portion facing upward.
3. Loosen the nut ⑤. Move the screw ⑥ so that the roller ④ of the thread trimmer driving lever will return smoothly when it is put into the groove of the thread trimmer cam ③.

6. ADJUSTMENT

6-12. Adjusting the thread trimming solenoid position

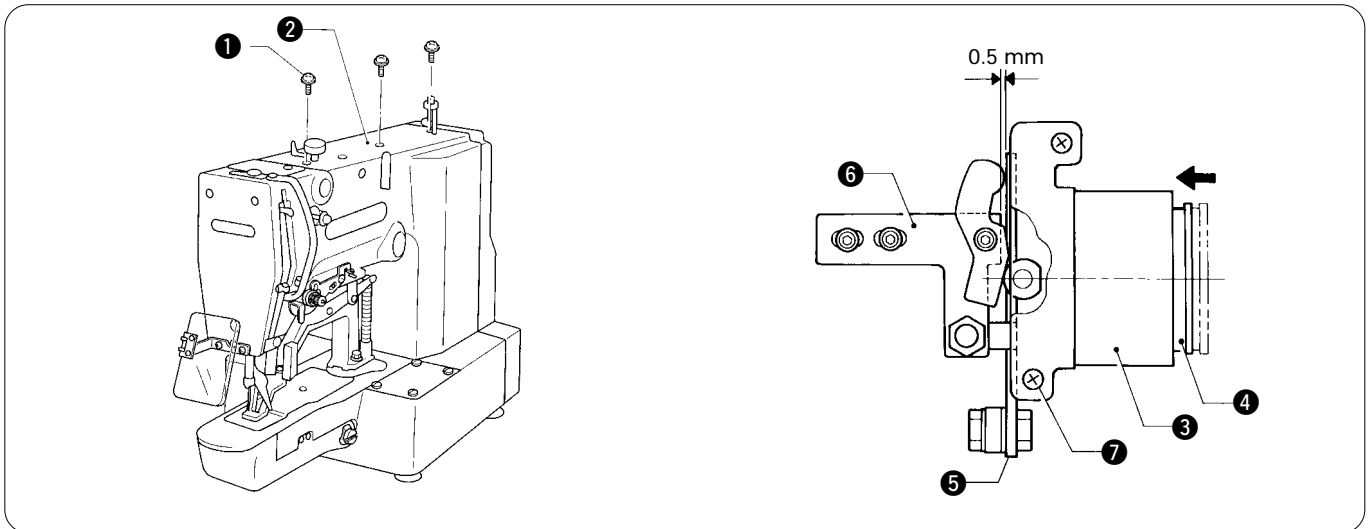

1. Remove the screws ① and the top cover ②.
2. Fully press the plunger ④ of the thread trimming solenoid ③, adjust the clearance between the thread trimmer driving lever ⑤ and the driving lever stopper ⑥ to 0.5 mm, and tighten the screw ⑦.

6-13. Adjusting the backlash

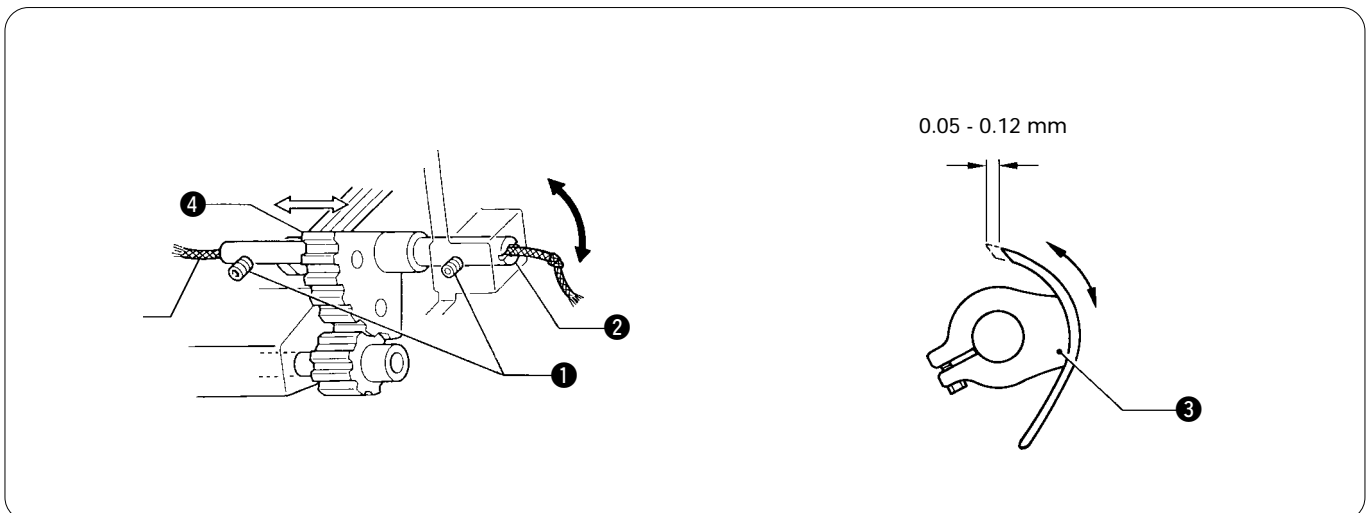

1. Loosen the set screw ①, and turn the rock gear shaft ② to adjust the play at the end of the driver ③ to 0.05 - 0.12 mm
2. After adjustment, move the rock gear shaft ② to the left and right so that the pulley can rotate easily, and tighten the set screw ①.

6-14. Adjusting the positions of the presser solenoid

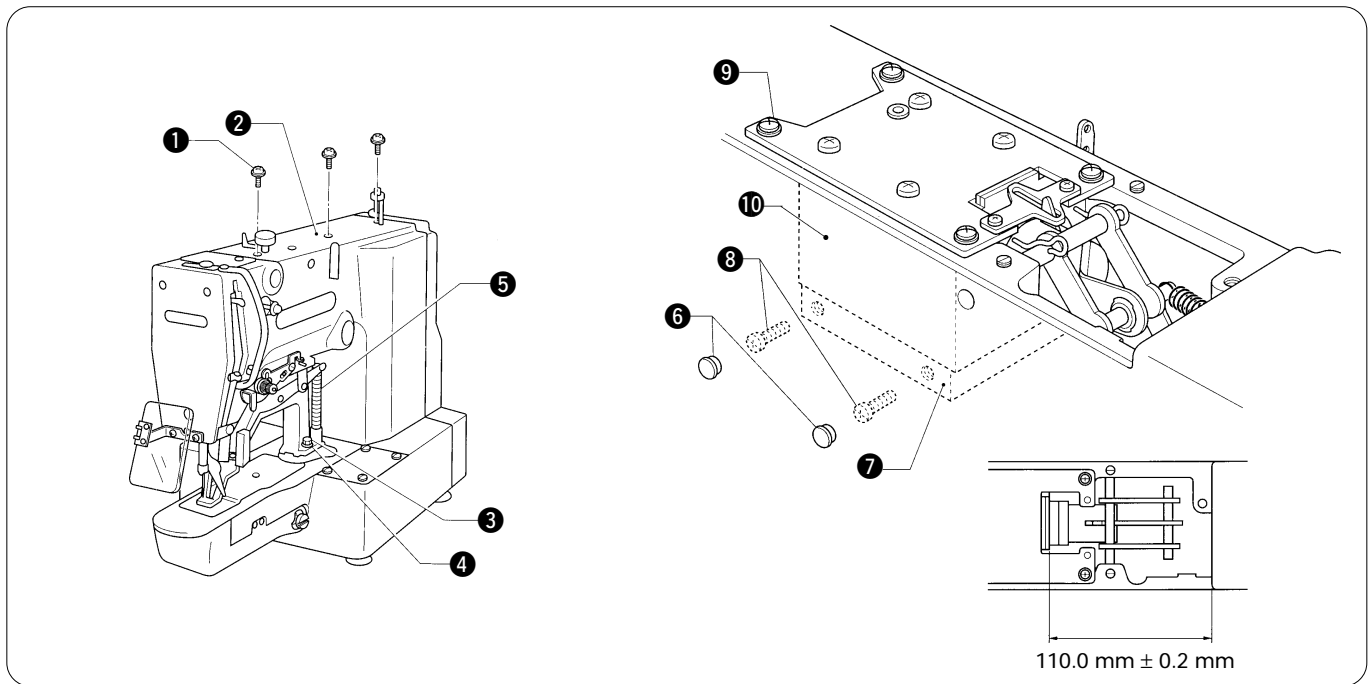

1. Remove the screws ① and the top cover ②.
2. Remove the bolt ③, the washer ④, and the presser arm ⑤.
* Pay attention not to let the ball bearing of the presser arm support shaft fall.
3. Remove the rubber cap ⑥, and loosen the screws ⑧ of the solenoid setting plate (B) ⑦.
4. Loosen the screw ⑨, adjust the position of the presser solenoid ⑩ so that it is positioned 110.0 ± 0.2 mm away from the shoulder of the machine. Tighten the screw ⑨.
* If this adjustment is not performed properly, the work clamp may not rise or lower properly, resulting in the occurrence of error E-60.

6-15. Adjusting the sensor perceive plate position

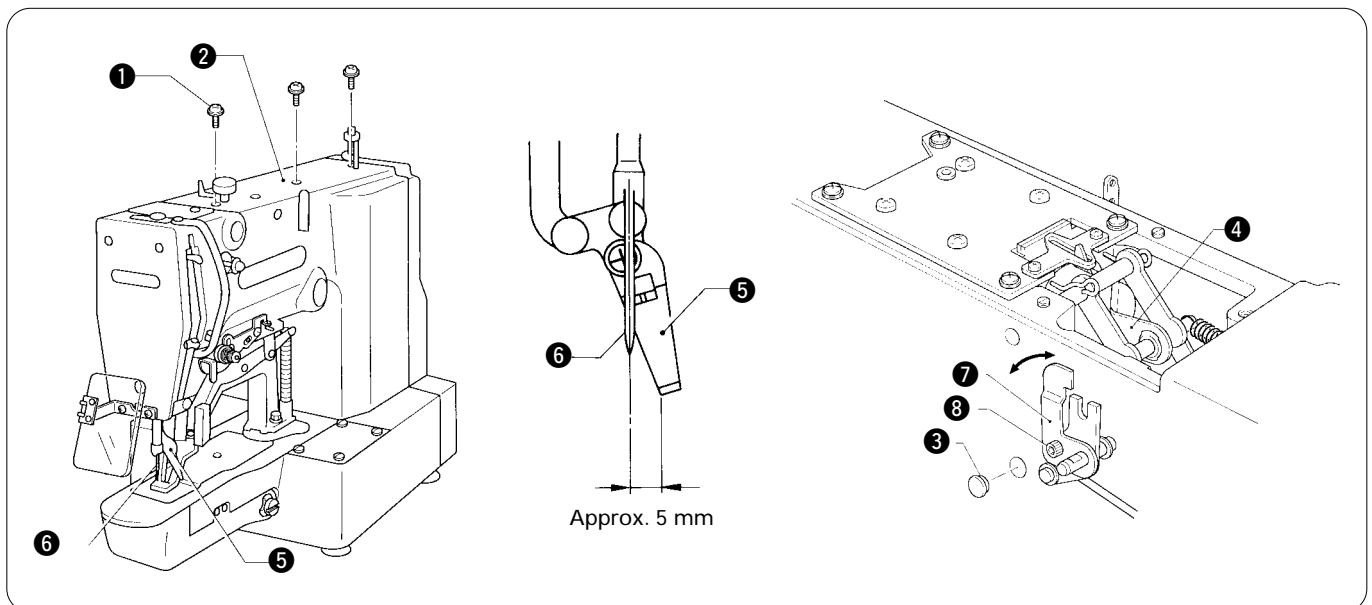

1. Remove the screws ① and the top cover ②.
2. Turn on the power, and change to the sensor mode on the operation panel. (Refer to page 72.)
3. Remove the rubber cap ③ from the side of the arm.
4. Press the link C assy ④ in the presser lifter mechanism. When the wiper ⑤ is 5 mm away toward the right from the needle ⑥, the presser signal should be ON. Loosen the screw ⑧ of the sensor perceive plate ⑦, and move the sensor perceive plate ⑦ back or forth to adjust it.

6. ADJUSTMENT

6-16. Adjusting the home position

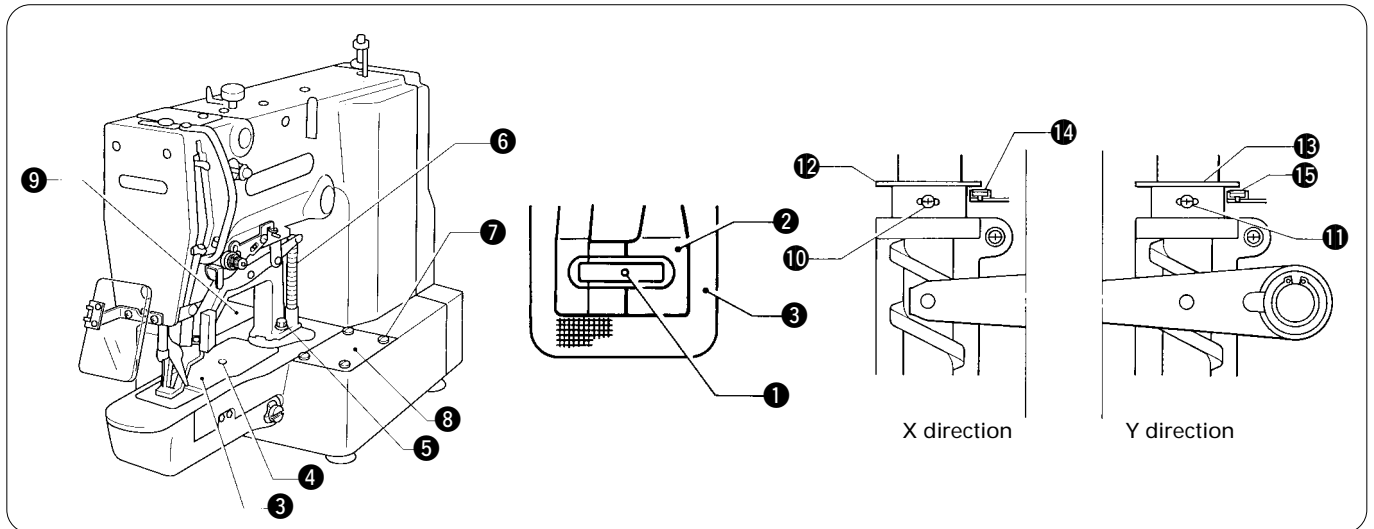

1. Following the instruction manual, turn on the power, set the program number to 00, and press the foot switch to set the home position of X and Y axes.
2. Turn off the power. Loosen the screw ④ and the bolt ⑤, and move the feed plate ③ and the presser arm ⑥ so that the needle plate ① comes to the center of the feed plate ③ and the presser arm ⑥.
* After that, turn on the power again to check the alignment.
3. If this adjustment does not make the alignment correct, loosen the screw ⑦ after turning off the power, and remove bed covers R ⑧ and L ⑨.
Loosen the screws ⑩ and ⑪, rotate the feed home position dogs ⑫ and ⑬ gradually, tighten screws again, and repeat step 1.
4. Turn off the power.
* If oil or grease is adhered to the home position sensors ⑭ and ⑮, or a wire is broken, error E-A0 may occur.

6-17. Adjusting the needle up stop position

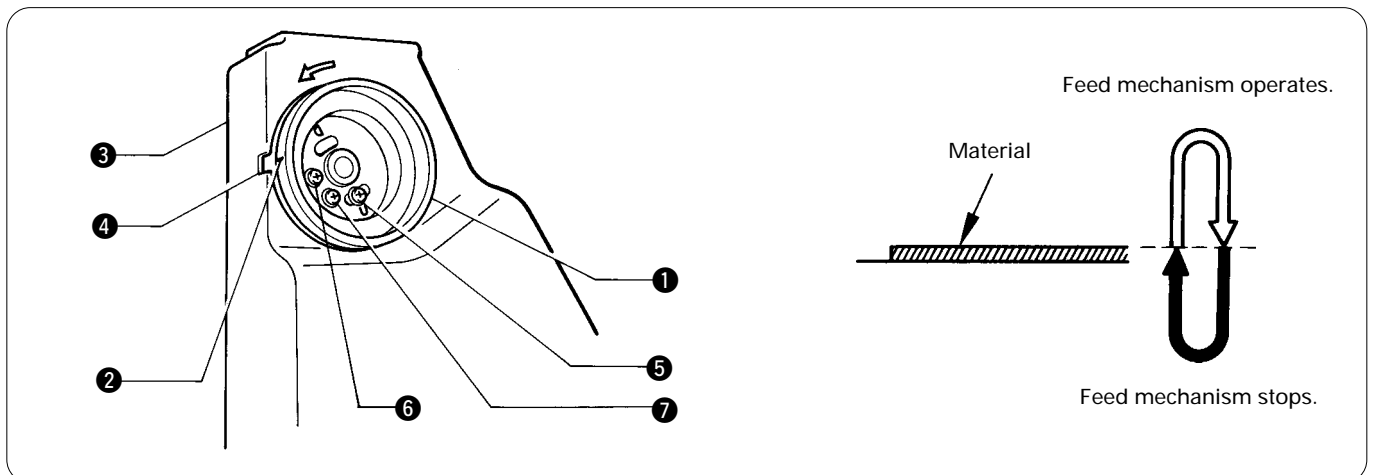

1. Loosen the screw ⑤ (at the U side on the pulley ①), and turn the pulley ① so that the mark ② on the pulley is inside the mark ④ of the belt cover ③.
The pulley ① stops later if it is turned clockwise; it stops earlier if it is turned counterclockwise.
The standard needle up stop position is 6 mm below the needle bar dead point.
Timing between the needle and the feed mechanism is adjusted so that the feed mechanism starts operating after the needle comes out of the material sewn, and stops before the needle penetrates the material.
* The screw ⑥ at the "D" mark is an adjusting screw for the needle down detection function and is adjusted to match the feed timing, so it should not be loosened.
* The screw ⑦ is a screw for detecting the machine stop position, and should not be loosened.

6-18. Adjusting the V-belt tension

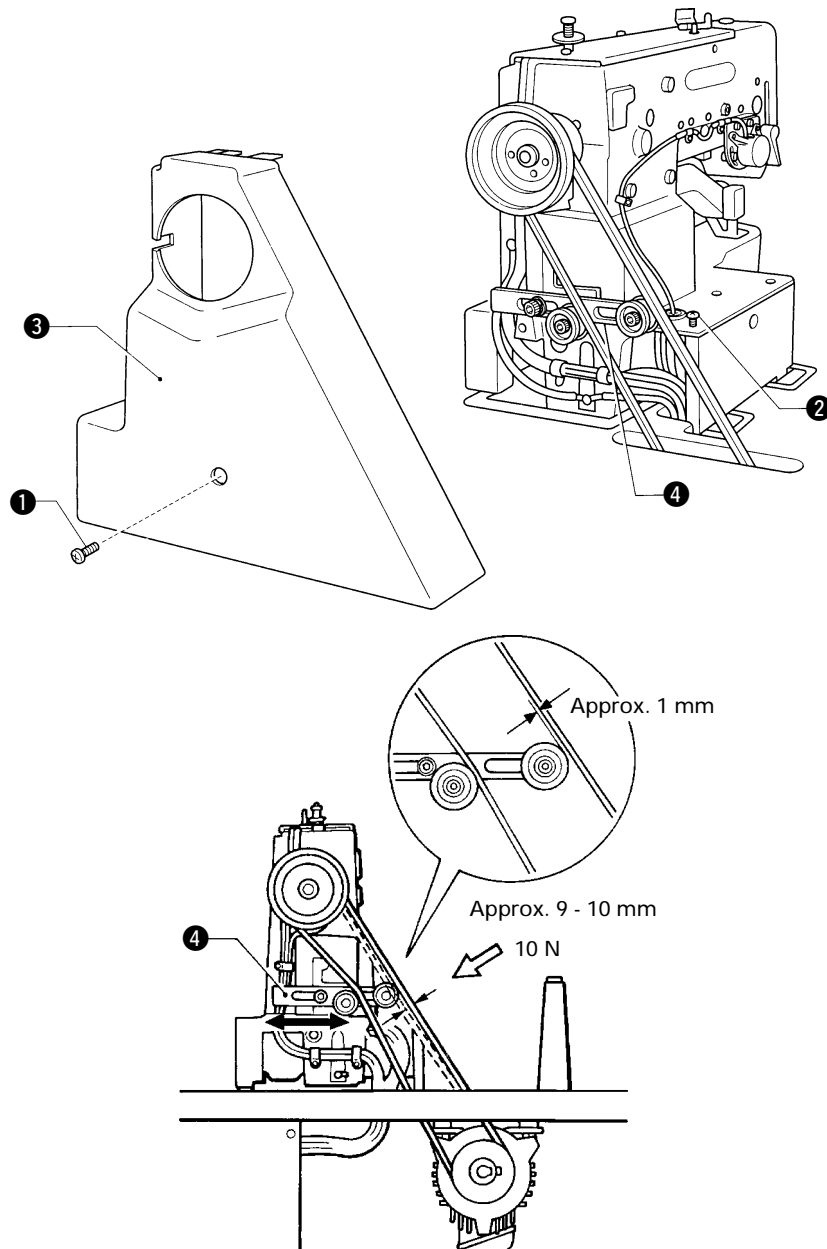

1. Remove the screw ①, loosen the screw ②, then remove the belt cover ③.
2. Press the center of the V-belt with a load of 10 N, and adjust the tension pulley ④ so that the V belt deflection is approximately 9 - 10 mm.
3. Adjust the right tension pulley so that there is a gap of about 1 mm between it and the V-belt.











* When the belt tension is weak, the following problems will occur;

- Noise & vibration become large.
- Needle up stop position becomes unstable.
- Error code [E-50] is displayed.





7. GAUGE PARTS LIST ACCORDING TO SUBCLASSES

The following are standard gauge parts according to each specification.

(In the following table, parts marked with ★ are common with the LK3-B430E; parts with ☆ are common with the BAS-311E.)

Subclass	-2	-1	-5	-7
Use				
Part name	For denim	For ordinary materials		For knitted materials
Needle hole plate 	(φ2.6) ☆ S10212-101 E	(φ2.2)	S49980-001 FM	(φ1.6) ☆ S10211-001 A
Bobbin case assy 	152690-301 B ★		159610-201 A ★	159610-201 A ★
	S15902-401 LA ☆		S15902-401 LA ☆	
Tension spring 	154340-001 B ★		154339-001 A ★	154339-001 A ★
	S16074-101 LA ☆		S16074-101 LA ☆	
Screw 		154341-001	★	154341-001 ★
		S16074-101 LA	☆	
Spring, anti-spin 	S15667-001 LA ☆		159612-001 A ★	159612-001 A ★
			S15667-001 LA ☆	
Bobbin 		159613-051	★	159613-051 ★
		S15665-001 LA	☆	
Shuttle hook book assy 	152687-902 B ★		152685-903 A ★	152685-903 A ★
	S15663-991 LB ☆		S15662-992 LA ☆	
Large shuttle hook 	152686-101 B ★		152682-101 A	★
Spring tension 	107606-001 ★		104525-001	★
Spring 	144588-001 B ★		145519-001	★

7. GAUGE PARTS LIST ACCORDING TO SUBCLASSES

Subclass	-2	-1	-5	-7
Use	For denim	For ordinary materials		For knitted materials
Part name	For denim	For ordinary materials		For knitted materials
Thread guide, needle bar 	★ 152890-001 A	★ S41222-001 B		★ 152890-001 A
Needle assy	★ S37928-419	107415-414		★ 107415-409
Needle 	★ DP × 17 NY #19 S37928-019	DP × 5 #14 107415-014		★ DP × 5 #9 107415-009
Work clamp arm assy	S49591-001	S49594-001	S49596-001	
Work clamp, U 	★ 5.6 × 23 (for 3mm use) R. 153608-101 L. 154527-001	★ 4 × 18 (for 2mm use) R. 152777-001 L. 152778-001	★ 4 × 12 (for 2mm use) R. 152779-001 L. 152780-001	
Feed plate 	S49697-001	12 × 31 (Submerged-type, L) S49698-001	12 × 24 (Submerged-type, S) S49700-001	5 × 13 (for 2mm use) S49699-001

Standard sizes for work clamps and feed plates are as follows:

(The actual sewing area has a 1.5 mm margin on every side; inside the lines which the dimensions indicate.)

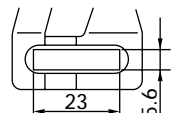
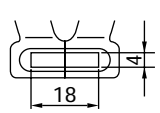
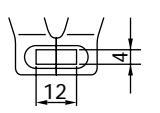
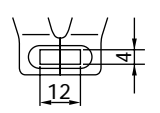
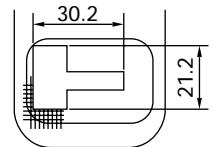
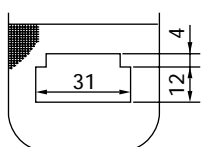
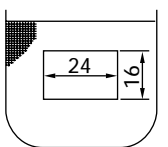
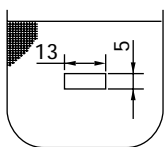
Spec.	-2	-1	-5	-7
R	153608-101	152777-001	152779-001	152779-001
L	154527-001	152778-001	152780-001	152780-001
Work clamp, U				
Feed plate	S49697-001 	S49698-001 	S49700-001 	S49699-001 

7. GAUGE PARTS LIST ACCORDING TO SUBCLASSES

<Gauge parts>

The following are provided as optional gauge parts.

Each work clamp pair is used in combination with the feed plate directly below them.

• Work clamps R, L (★) and feed plate

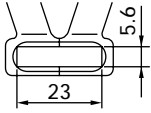
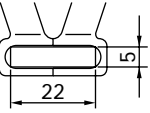
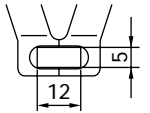
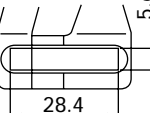
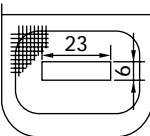
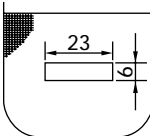
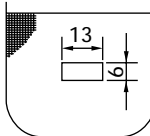
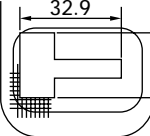
	1	2	3	4
R	152781-001 (For denim)	153201-001 (PL)	153203-001 (PS)	S00906-001 (1 Inch)
L	152782-001 (For denim)	153202-001 (PL)	153204-001 (PS)	S00907-001 (1 Inch)
Work clamp, U				
Feed plate	S49942-001 (For denim)	S49943-001 (PL)	S49944-001 (PS)	S49946-001 (1 Inch)
				

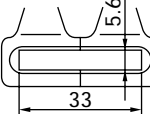
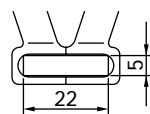
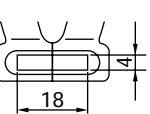
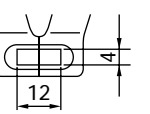
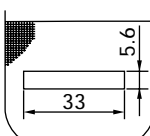
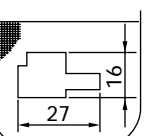
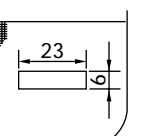
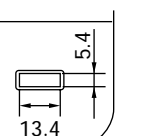
	5	6	7	8
R	S33747-001 (30mm)	153201-001 (For denim)	152777-001 (PM)	S49695-001 (F)
L	S33748-001 (30mm)	153202-001 (For denim)	152778-001 (PM)	S49694-001 (F)
Work clamp, U				
Feed plate	S49948-001 (30mm)	S49949-001(For denim)	S49943-001 (PL)	S49696-001 (F)
				

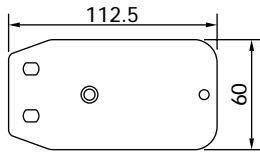
	9
Feed plate	S49945-001(MS)
	

7. GAUGE PARTS LIST ACCORDING TO SUBCLASSES

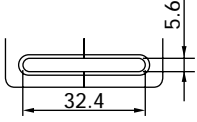
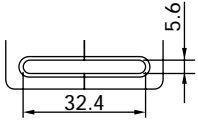
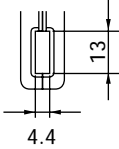
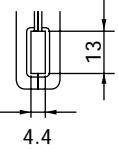
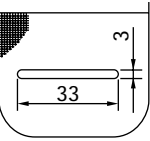
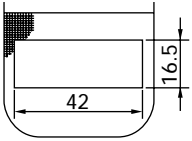
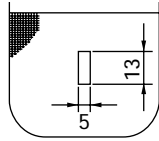
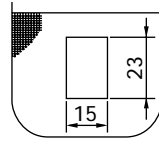
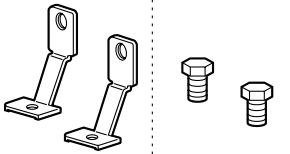
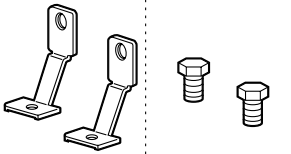
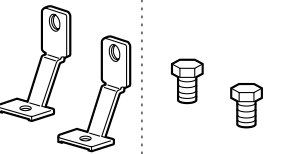
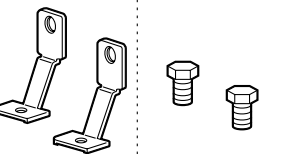
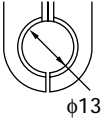
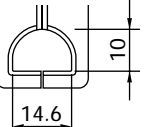
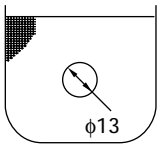
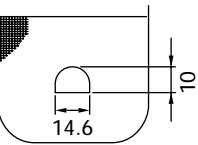
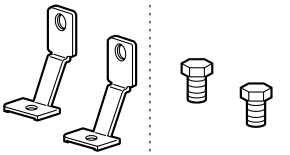
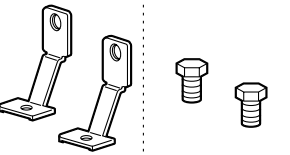
	10	11	12	13
R	S46771-001 (For straight bar tacking)	S46771-001 (For straight bar tacking/submerged)	S46774-001 (For vertical bar tacking)	S46774-001 (For vertical bar tacking/submerged)
L	S46770-001 (For straight bar tacking)	S46770-001 (For straight bar tacking/submerged)	S46773-001 (For vertical bar tacking)	S46773-001 (For vertical bar tacking/submerged)
Work clamp, U				
Feed plate	S49970-001 (For straight bar tacking)	S49974-001 (For straight bar tacking/submerged)	S49971-001 (For vertical bar tacking)	S49975-001 (For vertical bar tacking/submerged)
				
Work clamp, U Bolt	156006-001 : 017680-512	156006-001 : 017680-512	156006-001 : 017680-512	156006-001 : 017680-512
				
	14	15		
R	S46777-001 (For circular stitching)	S46780-001 (For crescent bar tacking)		
L	S46776-001 (For circular stitching)	S46779-001 (For crescent bar tacking)		
Work clamp, U				
Feed plate	S49972-001 (For circular stitching)	S49973-001 (For crescent bar tacking)		
				
Work clamp, U Bolt	156006-001 : 017680-512	156006-001 : 017680-512		
				

* Separate programs must be created if using 14 or 15.

7. GAUGE PARTS LIST ACCORDING TO SUBCLASSES

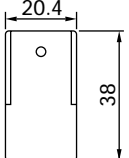
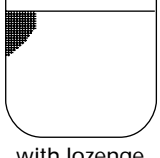
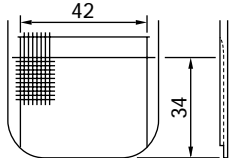
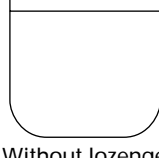
Work clamp, U blank	Feed plate blank		
155994-000	S49976-000	S49977-000	S49978-000
	 with lozenge		 Without lozenge

• Needle hole plate (☆)

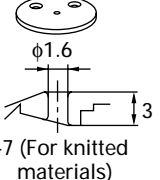
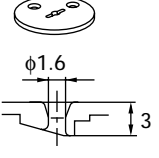
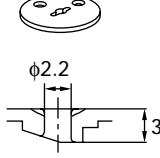
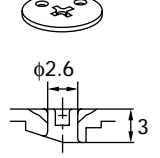
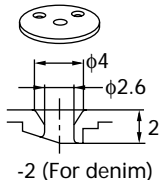
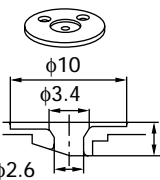
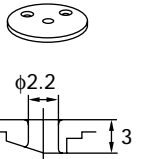
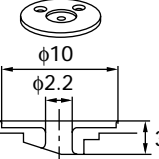
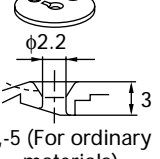
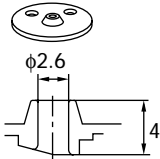
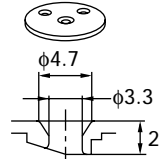
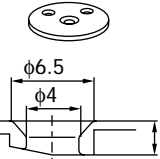
A	S10211-001	AF	S51449-001	BZ	S41013-001	D	S29997-001	E	S10212-101	ED	S30925-001
 -7 (For knitted materials)				 -2 (For denim)							
F	S10213-001	FD	S30926-001	FM	S49980-001	H	S30450-001	L	S25127-001	M	S34348-001
		 -1,-5 (For ordinary materials)									

8. OPTIONAL PARTS

- **Two-pedal foot switch** The presser switch and the start switch have been separated, giving the operator more flexibility to select the best method of working.

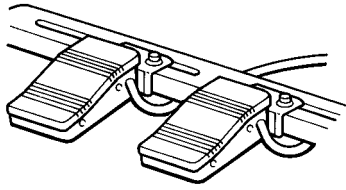

- **Two-step foot switch** This is a pedal-type foot switch.

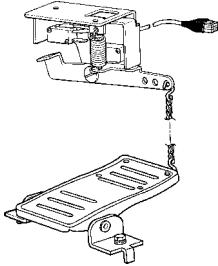

- **Liquid cooling tank** This helps to prevent thread breakages caused by friction when using synthetic threads. Fill the tank with silicone oil (100 mm²/S).

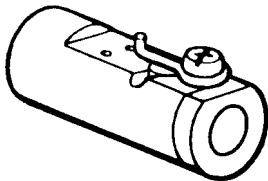

- **Work clamp set QC** The work clamp can be easily replaced by loosening the bolt and moving work clamp arm levers.

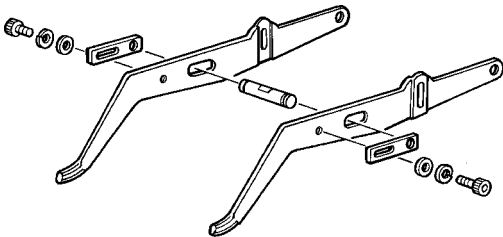

- **Solenoid thread wiper** This wipes the thread independently of the work clamp operation.

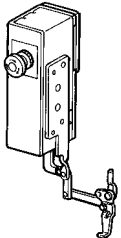

- **Thread take-up device** This ensures a longer upper thread trailing. (This thread take-up device is for denim material.)

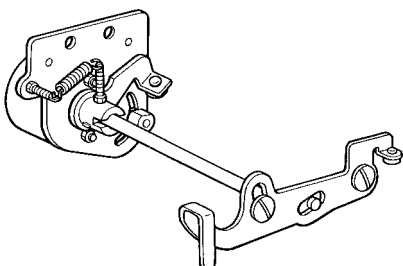

9. TROUBLESHOOTING

Problem	Cause	Check	Solution	Page
Work clamp does not rise.	Link operation is sluggish.	Solenoid position	Adjust solenoid position.	48
	Work clamp operation is sluggish.	Grease on work clamp	Apply grease to the sliding part of the work clamp.	29
	Too high work clamp lift stroke	Distance between work clamp and needle plate top	Adjust the height of the work clamp to 17 mm or less.	43
	Improper sliding of presser plate and presser arm lever plate	Grease on presser plate and presser arm lever plate	Apply grease to the presser plate and the presser arm lever plate.	29
	Work clamp makes contact with thread wiper.	Thread wiper stand-by position	Adjust the position of the thread wiper.	43
	Improper position of sensor perceive plate	Sensor perceive plate position	Adjust the position of the sensor perceive plate.	48
	Electrical trouble	See #7 work clamp does not rise" in the table in 10-12-2.	←	86
Work clamp does not lower.	Link does not return.	Spring	Hook the spring properly.	/
		Solenoid position	Adjust the solenoid position	48
	Electrical trouble	See #8 Work clamp does not lower" in the table in 10-12-2.	←	86
Insufficient work clamp lift stroke.	Improper position of presser arm lever plate	Distance between work clamp and needle plate top	Adjust the work clamp lift stroke.	43
Improper thread wiper operation	Thread wiper obstructs needle	Clearance between thread wiper and needle tip	Adjust the height of the thread wiper	43
	Improper position of thread wiper	Thread wiper position	Adjust the operating distance of the thread wiper.	43
Lower thread is wound to one side	Improper height of tension stud	Height of the tension stud	Adjust the height of the tension stud.	/
Insufficient lower thread wound	Improper position of bobbin presser	Wound lower thread amount.	Adjust the height of the bobbin presser.	/

Problem	Cause	Check	Solution	Page
Upper thread unthreaded	Stitches skipped at start of sewing	See "Skipped stitches occur."	←	
	Unstable thread length after thread trimming	Upper thread length after thread trimming	Adjust the sub tension.	4
	Thread take-up lever stroke is too great.	Thread take-up lever stroke	Adjust the thread take-up lever stroke.	44
	Turn the thread tension nut in the bobbin case to adjust the tension.	Turn the thread tension nut in the bobbin case to adjust the tension.	←	89
Upper thread breaks.	Upper thread tension is too great	Upper thread tension	Adjust the upper thread tension.	4
	Improper needle orientation	Needle orientation	Reinstall the needle with its long groove facing the front.	
	Thread is too thick for needle.	Upper thread and needle	Use the correct thread for the needle.	
	Improper tension and height of the thread take-up spring	Thread take-up spring tension and height	Adjust the tension and height of the thread take-up spring.	4
	Damaged or burred rotary hook, needle hole plate or needle	Scratches or burrs	File or replace the affected part.	
	Thread melting (synthetic thread)	Thread end	Use the thread cooling device.	
Lower thread breaks.	Lower thread tension is too great.	Lower thread tension	Adjust the tension of the lower thread.	4
	Damaged corners of needle hole plate or bobbin case	Damage	File or replace the affected part.	
Skipped stitches occur.	Excessive clearance between needle and rotary hook tip	Clearance between needle and rotary hook point	Adjust the needle clearance between the needle and the rotary hook point.	42
	Improper timing between needle and rotary hook	Needle bar lift stroke	Adjust the needle bar lift stroke.	41
	Driver is contacting needle more than is necessary.	Clearance between driver and needle	Adjust the driver needle guard.	42
	Needle bent	Needle curve	Replace the needle with a new one.	
	Needle improperly installed	Needle orientation	Reinstall the needle with its long groove facing the front.	

9. TROUBLESHOOTING

Problem	Cause	Check	Solution	Page
Needle breaks.	Needle is interfering with rotary hook.	Clearance between needle and rotary hook point	Adjust the clearance between the needle and rotary hook point.	42
		Needle bar lift stroke	Adjust the needle bar lift stroke.	41
	Needle is bent	Needle curve	Replace the needle with a new one.	/
	Sideways needle movement	Needle and feed timing	Adjust the needle down detection position.	49
	Needle is too thin.	Needle and thread	Use the correct needle for the material.	/
	Electrical trouble	See #15 "The machine cannot produce correct stitches" in the table in 10-12-2.	←	89
Upper or lower thread is not trimmed.	Fixed knife is blunt.	Fixed knife blade	Sharpen or replace the fixed knife.	/
	Movable knife does not pick up the thread.	Rotary hook thread guide	Adjust the position of rotary hook thread guide.	42
		Needle bar lift stroke	Adjust the needle bar lift stroke.	41
	Movable knife does not pick up the thread because of skipped stitches at the end of sewing.	Skipped stitches at the end of sewing	See "Skipped stitches occur."	/
	Improper position of movable knife	Movable knife position	Adjust the position of the movable knife.	44
	Sub tension is insufficient.	Sub tension	Turn the tension nut to adjust the tension.	/
	Electrical trouble	See #16 "The thread trimmer does not operate" in the table in 10-12-2.	←	89
Lower thread tension is insufficient	Lower thread tension	Turn the thread tension nut in the bobbin case to adjust the tension.	/	
Thread jamming	Inadequate tension and height of thread take-up spring	Tension and height of thread take-up spring	Adjust the tension and height of the thread take-up spring.	4
	Improper needle and rotary hook timing	Needle bar lift stroke	Adjust the needle bar lift stroke.	41
	Rotary hook thread guide does not separate upper and lower threads.	Rotary hook thread guide position	Adjust the position of the rotary hook thread guide.	42
	Upper thread tension is insufficient	Main tension	Turn the tension nut to adjust the tension.	/

Problem	Cause	Check	Solution	Page
Poor stitching on reverse side of material	Rotary hook thread guide does not separate upper and lower threads properly.	Rotary hook thread guide position	Adjust the position of the rotary hook thread guide.	42
	Improper upper thread tension	Upper thread tension	Adjust the upper thread tension.	4
	Unstable upper thread length after thread trimming	Upper thread length after thread trimming	See "unstable upper thread length."	
	Thread take-up lever stroke is too great.	Thread take-up lever stroke	Adjust the thread take-up lever stroke.	44
Poor stitching	Upper thread tension is insufficient.	Upper thread tension	Adjust the upper thread tension.	4
	Lower thread tension is insufficient.	Lower thread tension	Adjust the lower thread tension	4
	Improper tension and height of thread take-up spring	Thread take-up spring tension and height	Adjust the tension and height of the thread take-up spring.	4
Unstable upper thread length	Improper tension and height of thread take-up spring	Thread take-up spring tension and height	Adjust the tension and height of the thread take-up spring.	4
	Improper adjustment of sub tension	Sub tension	Adjust the sub tension.	
	Needle up stop position fluctuates.	See "Unstable needle up stop position."	←	
	Fixed knife is blunt.	Fixed knife blade	Sharpen or replace the fixed knife.	
	Thread take-up lever stroke is too great.	Thread take-up lever stroke	Adjust the thread take-up lever stroke.	44
Unstable needle up stop position	Inadequate adjustment of V-belt tension	Tension pulley position	Adjust the tension of the V belt using the tension pulley.	50
	Electrical trouble	See #18 "The machine does not stop with the needle at the upper position after thread trimming" in the table in 10-12-2.	←	90

10. ELECTRIC MECHANISM

10-1. Precautions at the time of adjustment

Pay attention to the following when opening the control box for maintenance.

■ Electric shock

Some large capacitors may have a high voltage remaining in them for up to 5 minutes after the power is turned off. To prevent electric shock, wait at least 5 minutes after the power is turned off before doing the following:

- Opening and closing the control box
- Replacing fuses
- Separating and joining connectors
- Measuring resistance
- Doing anything with a possibility of touching something inside the control box

Some adjustments require measuring the voltage while the power is turned on with the control box kept open.

In such a case, be careful not to touch any place other than that for the measurement. In addition, always keep in mind that a high voltage remains for 5 minutes after the power is turned off.

■ Injury

While the power is turned on, the cooling fan of the control box operates; be careful not to get caught in it. When separating or rejoining connectors, and measuring something, be careful not to cut your fingers on metal parts such as heatsinks and covers.

10-2. Components inside the control box and the operation panel

The following are brief explanations of components inside the control box. See control circuit block diagram at the end of this manual for the details of the connections.

◆ Main circuit board

The main circuit board is fixed to the rear panel of the control box. This PCB serves to control machine operation.

◆ Power supply circuit board

The power supply circuit board is fixed at the bottom of the control box. Four fuses are mounted on this PCB.

◆ Panel PCB

The panel PCB is fixed to the front panel of the operation panel. This PCB controls indications of the machine status and the input operation.

◆ DC fan motor

The DC fan motor serves as a fan to cool the inside of the control box. Clean the inlet filter monthly.

◆ Conversion transformer (depending on power supply voltage specification)

The conversion transformer controls the power supply voltage to provide 220 V.

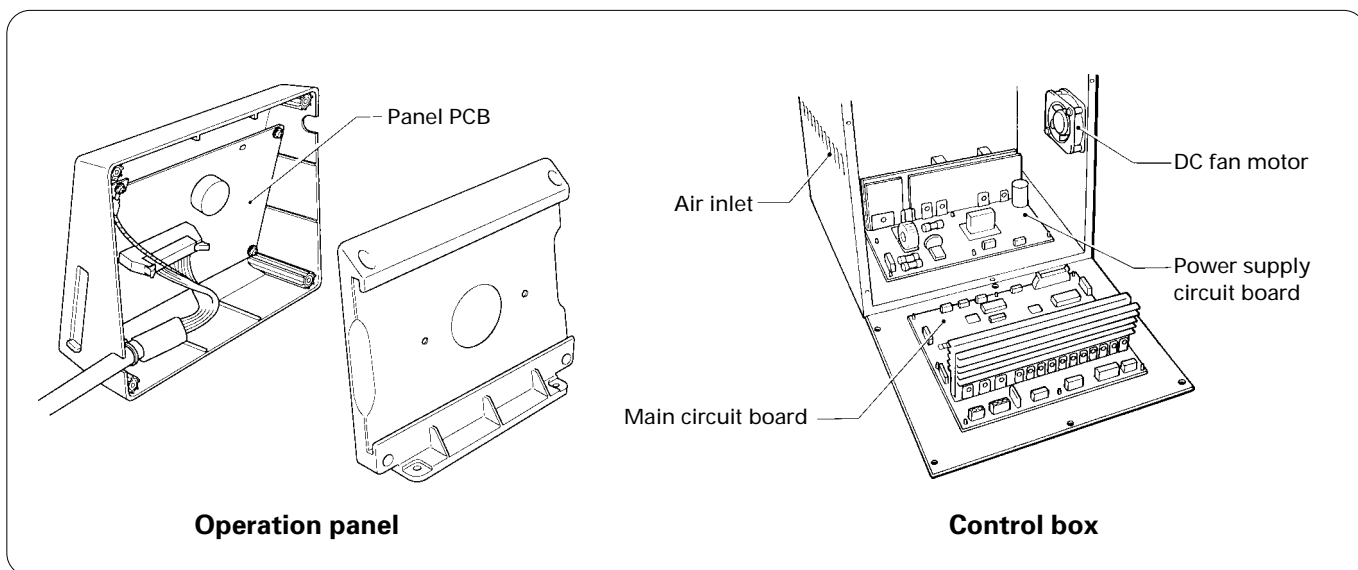

10-3. Fuse explanation

When replacing a fuse, follow the instructions indicated in "10-12. Troubleshooting flowchart."
 If a component on a PCB is damaged, a fuse may blow again immediately even when it has been replaced.
 When replacing a fuse, be sure to use the specified ones listed below.

No.	Part name	Part code	When a fuse has blown
1	G fuse (5AFB) (quick melting type, 5A-250V)	S08030-000	The feed mechanism and work clamp do not operate. Error E-A0 is displayed.
2	G fuse (7AFB) (quick melting type, 7A-250V)	S48580-000	The machine motor does not turn. Error E-20 is displayed.
3	Fuse 6A (glass tube fuse, 6A-250V)	153242-000	The power lamp is not lit, and nothing operates.
4	Fuse 6A (glass tube fuse, 6A-250V)	153242-000	The power lamp is not lit, and nothing operates.

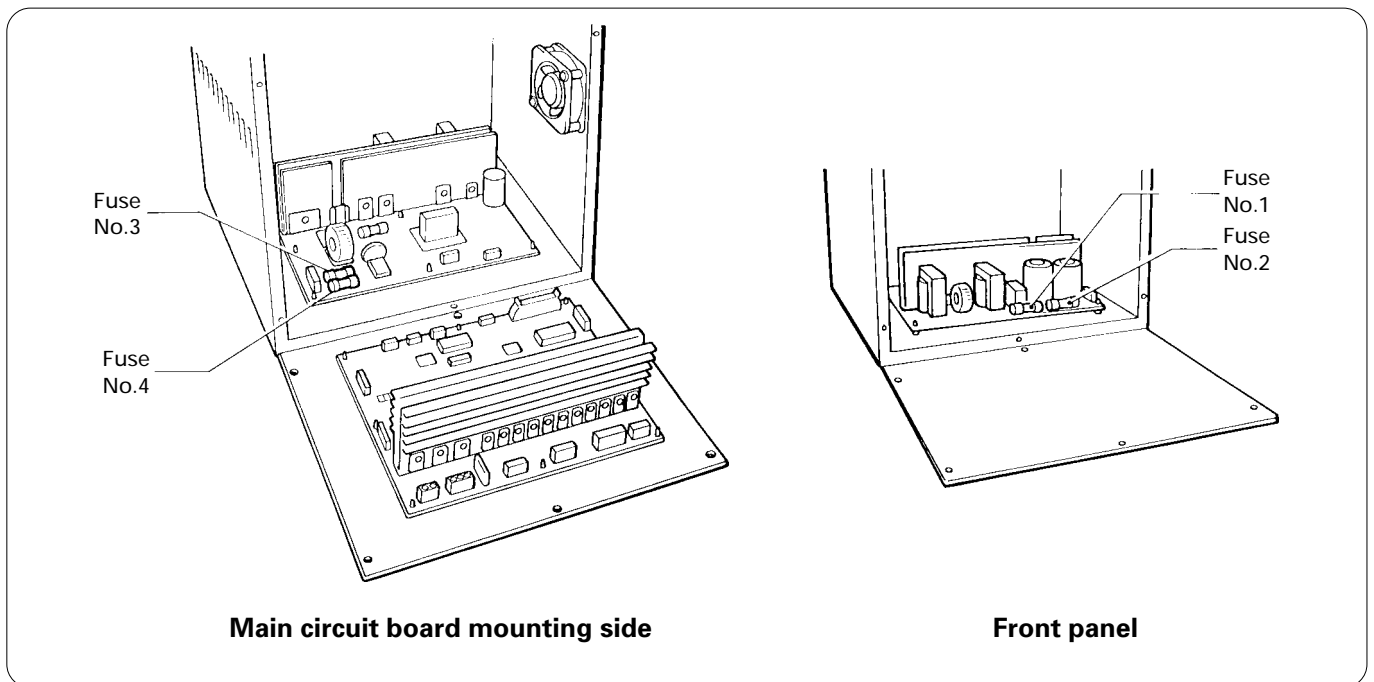

10. ELECTRIC MECHANISM

10-4. Connectors

Most of the machine trouble is due to connector problems including improper connection or insufficient contact. Therefore, be sure to check if each connector is correctly inserted and that there is no contact failure between pins and wires before starting troubleshooting procedures.

■ Connector positions

Outside of the control box

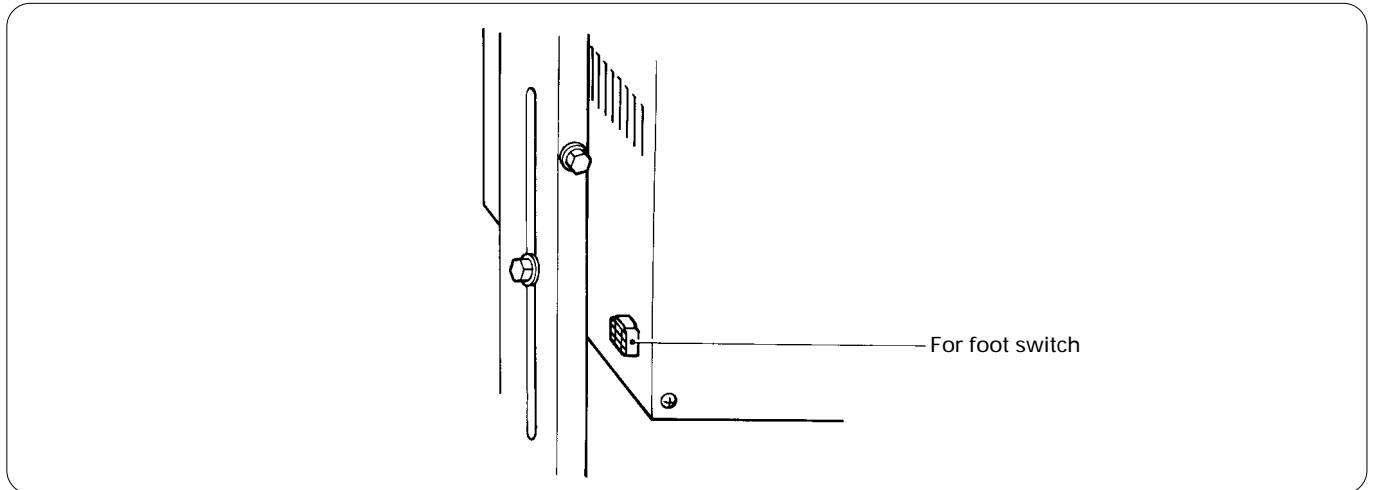

Main circuit board

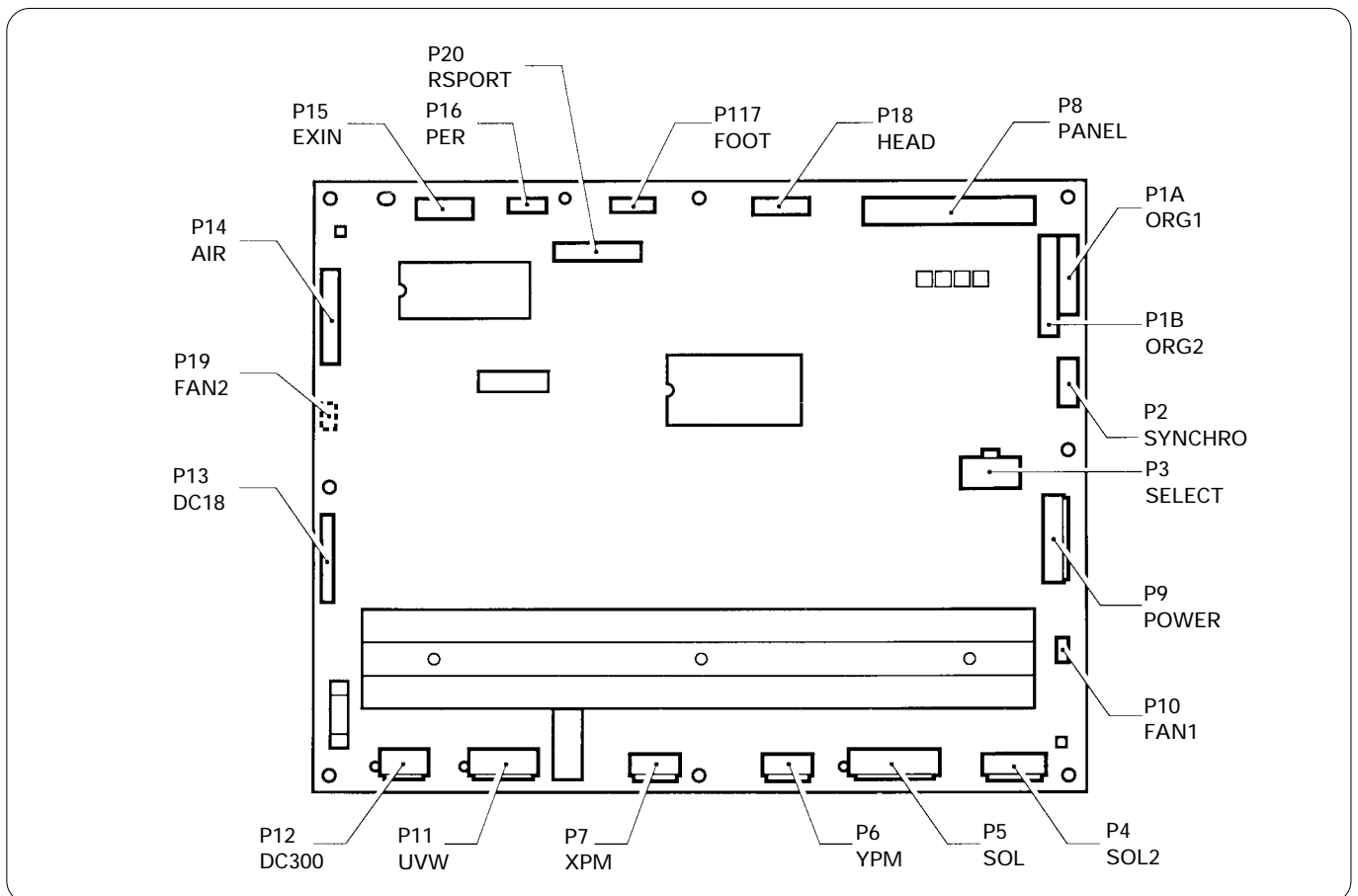

Power supply circuit board

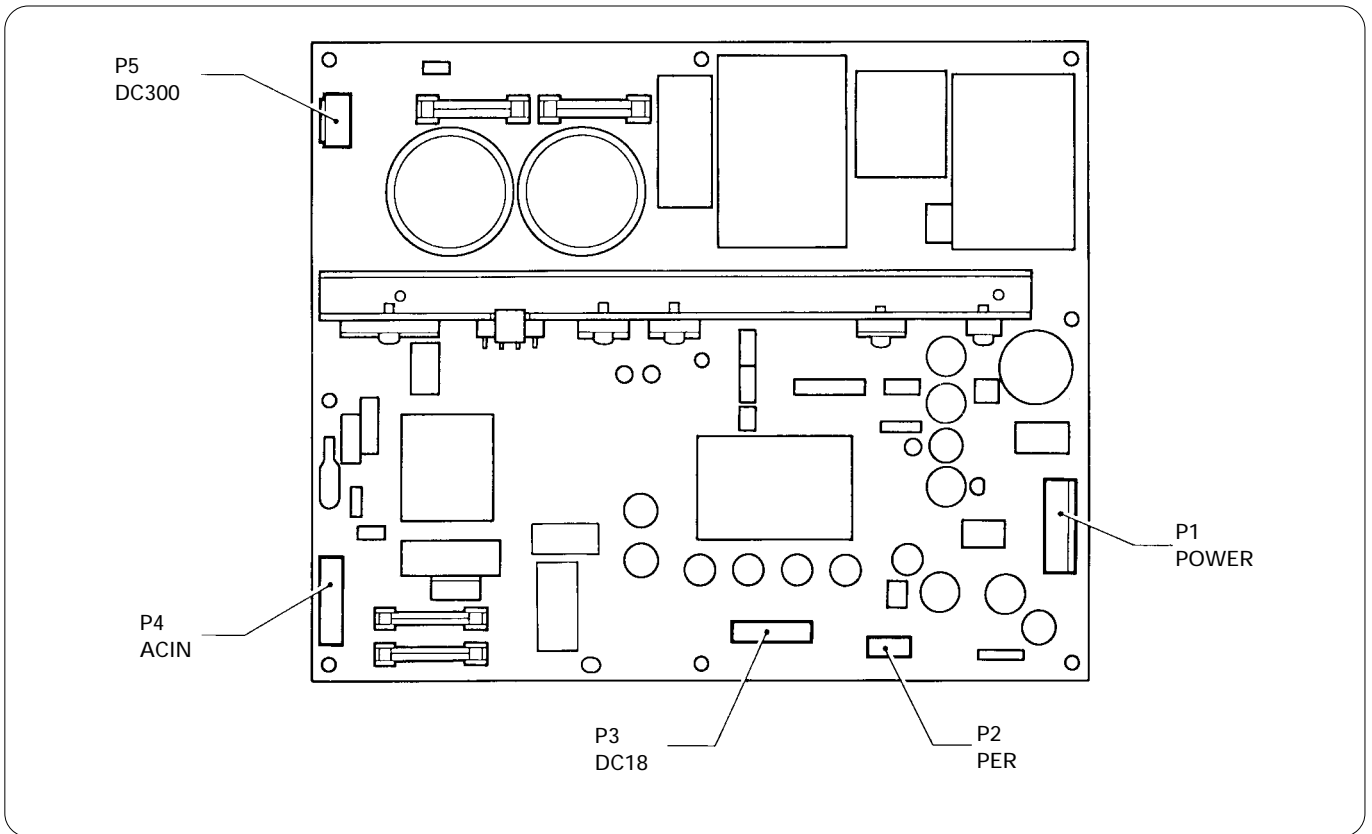

Panel PCB

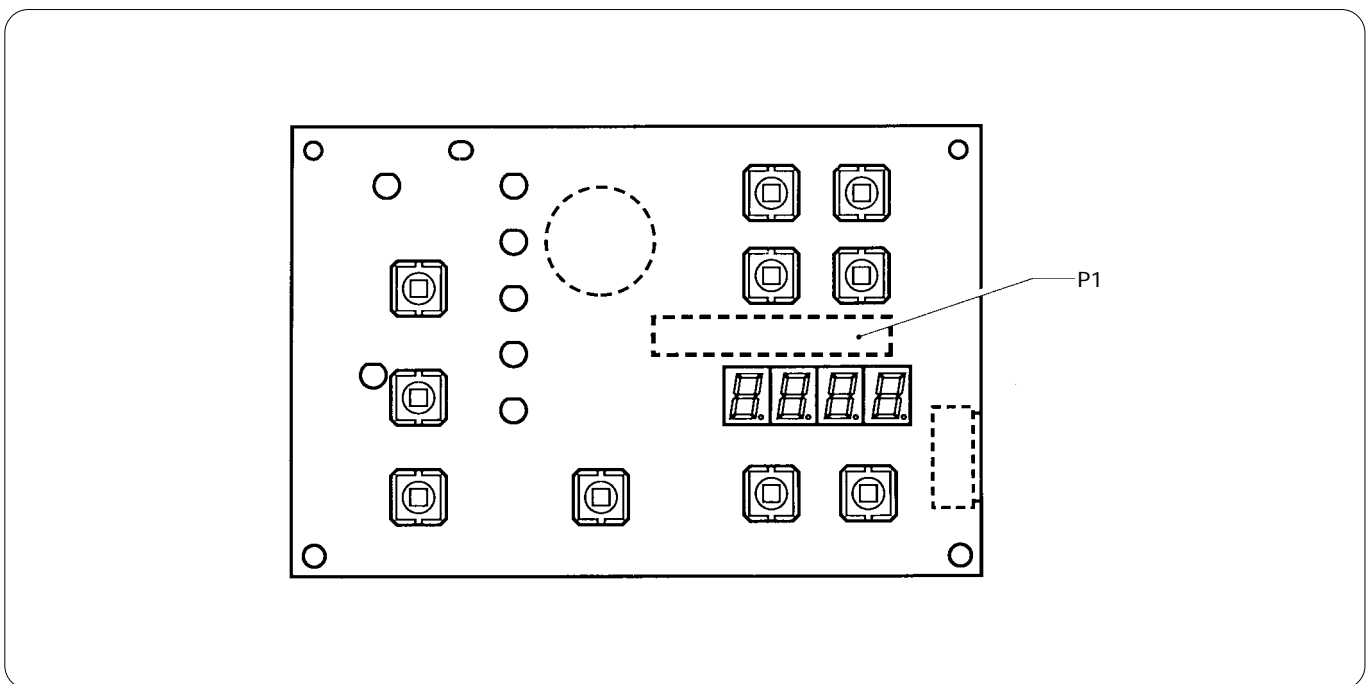

10. ELECTRIC MECHANISM

■ Contact failure

The connectors functions are divided into four categories. Some connectors may belong to more than one group. Be sure to investigate another category if a problem is not found in one category.

For the details of connections, refer to the control circuit block diagram at the end of this manual.

1. Feed mechanism

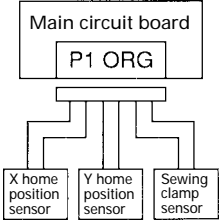
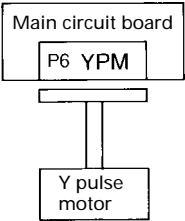
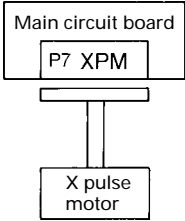
Problem	Connector No. and position
<ul style="list-style-type: none"> Home position is not properly detected. Error E-A0 is displayed. The work clamp does not operate. Error E-60 is displayed. 	
<ul style="list-style-type: none"> Forward feed does not operate correctly. Error E-A0 is displayed. 	
<ul style="list-style-type: none"> Sideways feed does not operate correctly. Error E-A0 is displayed. 	

2. Work clamp lifter and thread trimmer mechanisms

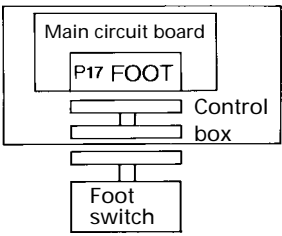
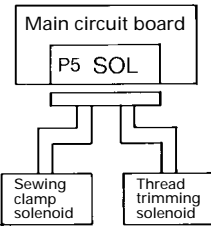
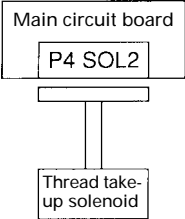
Problem	Connector No. and position
<ul style="list-style-type: none"> The work clamp does not operate. The machine does not operate. 	
<ul style="list-style-type: none"> The work clamp does not operate. Thread trimming is not performed. Error E-61 is displayed. 	
<ul style="list-style-type: none"> Thread take-up lever does not operate. 	

3. Sewing operation

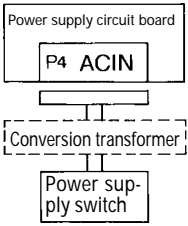
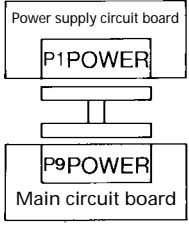
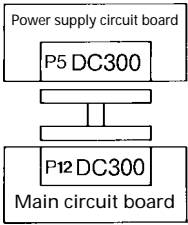
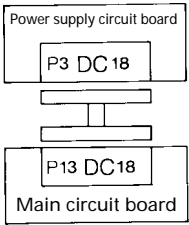
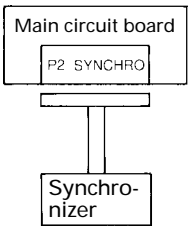
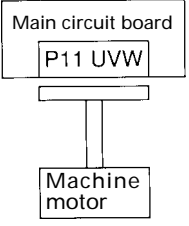
Problem	Connector No. and position
<ul style="list-style-type: none"> • The power lamp is not lit, and nothing operates. • Machine operation is unstable. 	 <pre> graph TD A[Power supply circuit board P4 ACIN] --- B[Conversion transformer] B --- C[Power supply switch] </pre>
<ul style="list-style-type: none"> • The power lamp is not lit, and nothing operates. • Machine operation is unstable. • The feed mechanism does not operate. • The work clamp lifter mechanism does not operate. • Error E-61 is displayed. • Error E-A0 is displayed. 	 <pre> graph TD A[Power supply circuit board P1POWER] --- B[Main circuit board P9POWER] </pre>
<ul style="list-style-type: none"> • The machine motor does not run. • Motor operation is unstable. • Needle up stop position is not correct. • Error E-20 is displayed. • Error E-50 is displayed. 	 <pre> graph TD A[Power supply circuit board P5 DC300] --- B[Main circuit board P12 DC300] </pre>
<ul style="list-style-type: none"> • The machine motor does not run. • Motor operation is unstable. • Needle up stop position is not correct. • Error E-20 is displayed. • Error E-50 is displayed. 	 <pre> graph TD A[Power supply circuit board P3 DC 18] --- B[Main circuit board P13 DC18] </pre>
<ul style="list-style-type: none"> • The machine motor does not run. • Motor operation is unstable. • Needle up stop position is not correct. • Error E-20 is displayed. • Error E-50 is displayed. 	 <pre> graph TD A[Main circuit board P2 SYNCHRO] --- B[Synchronizer] </pre>
<ul style="list-style-type: none"> • The machine motor does not run. • Motor operation is unstable. • Needle up stop position is not correct. • Error E-20 is displayed. • Error E-50 is displayed. 	 <pre> graph TD A[Main circuit board P11 UVW] --- B[Machine motor] </pre>

10. ELECTRIC MECHANISM

4. Others

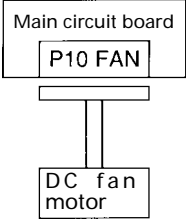
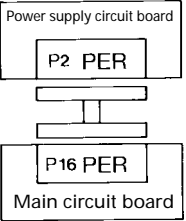
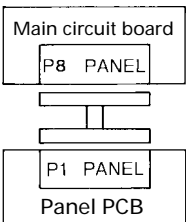
Problem	Connector No. and position
<ul style="list-style-type: none"> The DC fan motor does not run. Error E-70 is displayed. 	 <pre> graph TD A["Main circuit board P10 FAN"] --- B["DC fan motor"] </pre>
<ul style="list-style-type: none"> Error E-F1 is displayed. 	 <pre> graph TD A["Power supply circuit board P2 PER"] --- B["P16 PER Main circuit board"] </pre>
<ul style="list-style-type: none"> Indication is strange. Any switch does not have any effect. The power lamp is not lit. 	 <pre> graph TD A["Main circuit board P8 PANEL"] --- B["P1 PANEL Panel PCB"] </pre>

10-5. Explanation of the DIP switches

10-5-1. Operation panel DIP switches

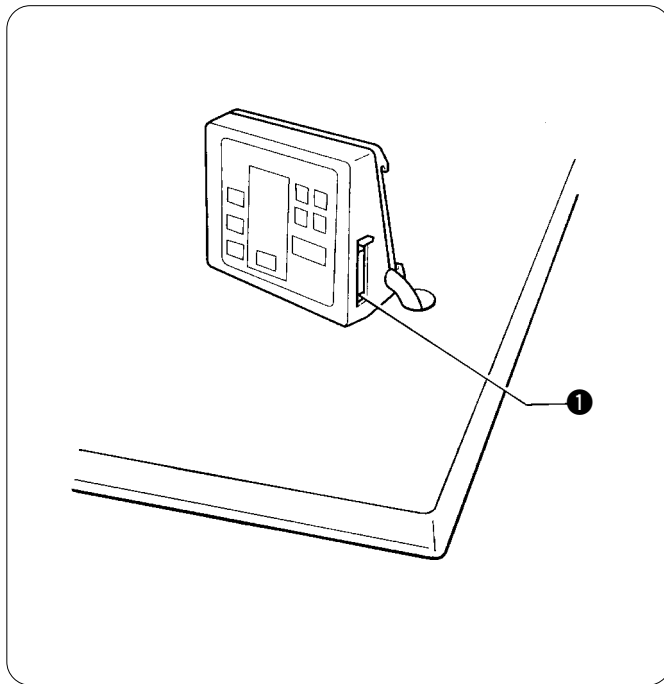

The operation panel DIP switches ❶ are used to change functions which might need to be changed depending on the sewing conditions.

NOTE: Always turn off the power before setting the DIP switches.

The functions shown in the table below can be changed by means of these DIP switches.

* All DIP switches are set to OFF at the time of shipment.

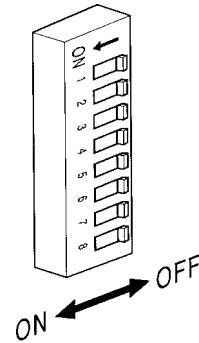

Switch	Motion when set to ON	
DIPA-1	Presser does not automatically lift after sewing is completed.	See "10-5-2. Setting the presser mode"
DIPA-2	Two-pedal mode is available.	
DIPA-3	User program mode is available.	
DIPA-4	—	
DIPA-5	The presser does not rise automatically when a split is found.	
DIPA-6	Displays the enlargement/reduction ratio in millimeter units instead of as a percentage. (After changing this setting, be sure to carry out the auto-clear operation by referring to page 73.)	
DIPA-7	Enlargement of pattern size is not available.	
DIPA-8	Program number is fixed.	

10-5-2. Setting the presser mode

Through the combination of DIP switches A-1 and A-2 on the operation panel, presser motions can be set as follows:

DIPA-1	DIPA-2	Pedal specifications	Raising the presser at the sewing end
—	—	Single pedal	Presser is raised automatically.
ON	—	Single pedal	Presser is raised by pressing the pedal.
—	ON	Two pedals	Presser is raised automatically, then it is lowered by pressing the pedal.
ON	ON	Two pedals	Presser is kept lifted while the pedal is pressed.

10. ELECTRIC MECHANISM

10-5-3. DIP switches inside the control box

⚠ DANGER



Wait at least 5 minutes after turning off the power switch and disconnecting the power cord from the wall outlet before opening the face plate of the control box. Touching areas where high voltages are present can result in severe injury.

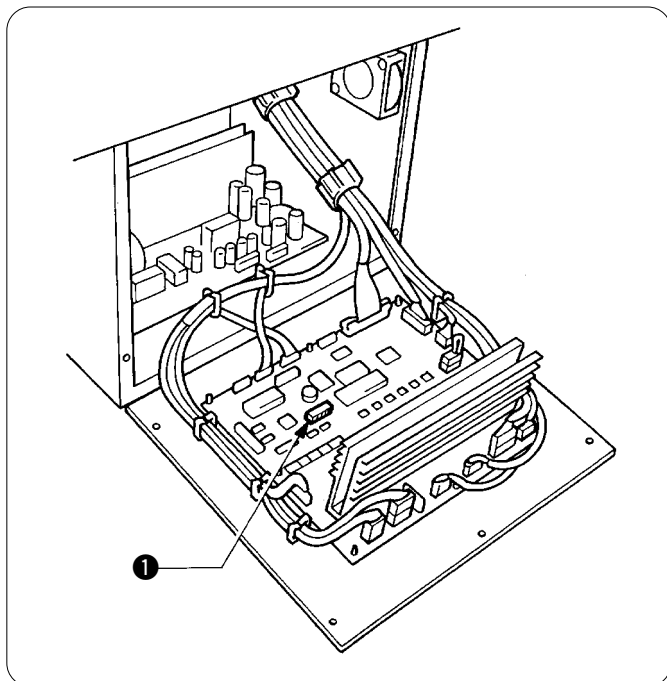

The DIP switches ❶ inside the control box are used to change functions which do not often need to be changed once they have been set.

The functions can be changed as shown in the table below by changing the positions of the DIP switches ❶.

* All DIP switches are set to OFF at the time of shipment.

NOTE: When opening the cover, hold it securely so that it does not fall down.

Switch	Motion when set to ON
DIPB-1	First two stitches are sewn at a low speed of 260 rpm.
DIPB-2	Last two stitches are sewn at a low speed of 260 rpm.
DIPB-3	—
DIPB-4	Last two stitches are sewn at a low speed of 700 rpm.
DIPB-5	First two stitches are sewn at a low speed of 400 rpm.
DIPB-6	Low speed sewing is not performed at the start of sewing.
DIPB-7	The motor operates in reverse when the upper shaft stops, to return the needle bar to close to its highest position.
DIPB-8	Area checking of the sewing data is not carried out.

10-6. Explanation of the memory switches

The functions of the switches on the operation panel ❶ can be changed to carry out special functions.

NOTE: After changing the memory switch settings, press the power switch to turn the power off and then back on again.

The memory switches "00-2F" are set to OFF at the time of shipment.

1. Turn on the power switch.
2. While pressing the TEST switch ❷, press the BOBBIN. WIND switch ❸.

* "00--" will appear in the display window ❹.

3. Press the DISPLAY SET switches ❺ to set the two digits at the left of the display window ❹ to the corresponding number (00 to 4F) of the function shown in the table below that you would like to select.

4. When the BOBBIN. WIND switch ❸ is pressed, the two spaces at the right in the display window will change from "--" to "ON".

* If you press the RESET switch ❻ at this time, memory switches from 00 to 2F will all be set to OFF ("--"), and memory switches from 30 to 4F will be returned to their initial settings.

5. Press the TEST switch ❷.

* The display window will return to normal.

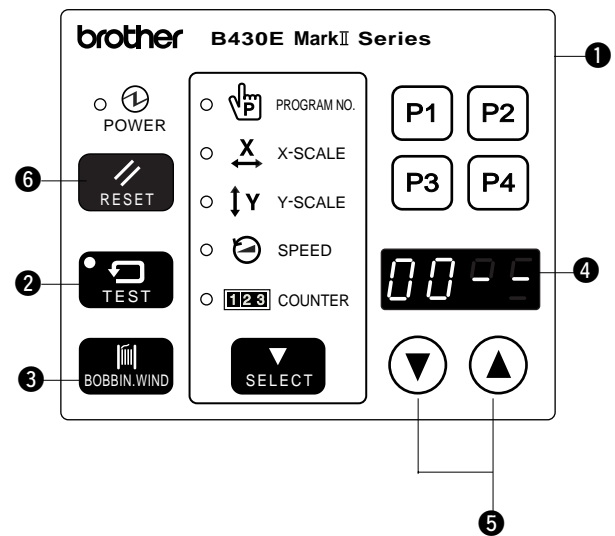

■ Memory switches 00 – 0F

Switch	Motion when set to ON
memo-00	At the end of sewing, the feed plate will be returned to the sewing start point via mechanical home position.
memo-01	Work clamp will move to the sewing start point, and then will be lifted. (The work clamp rises at the final stitch to enable the quick taking out of the workpieces.)
memo-02	Feed will move automatically to the next starting point at the same time as a user program is switched. (Normally it moves to the starting point after sewing starts.)
memo-03	When sewing using programs, the programs which have been set will be sewn in numerical order. (Cycle sewing mode is set.)
memo-04	The sewing speed will be fixed at the minimum speed for the maximum pitch of the sewing data. (Set this to ON if you are concerned that variations in pitch may cause changes in the sewing speed.)
memo-05	Increases the presser solenoid lifting force (Set to ON when using the optional spring for extra-heavy material)
memo-06	Enlargement and reduction ratio settings for X and Y become the same.
memo-07	—
memo-08	Test feeding is carried out stitch by stitch when the foot switch is depressed.
memo-09	The sewing start point becomes the reference point for enlargements and reductions. (The reference point for enlargements and reductions is normally the center of the sewing frame.)
memo-0A	—
memo-0b	—
memo-0c	Needle stops in up position during emergency stop. (EMERGENCY STOP switch is available as an option.)
memo-0d	The bar tacking stitches (with a pitch of less than 1 mm) are also enlarged and reduced. (Normally stitches with a pitch of less than 1 mm are not enlarged or reduced.)
memo-0E	Test feeding will be performed at the same speed as that for actual sewing. (This is used for checking feeding operation.)
memo-0F	After sewing is finished, the work clamp automatically opens and closes once (practice operation).

10. ELECTRIC MECHANISM

■ Memory switches 10 – 1F

Switch	Motion when set to ON
memo-10	The optional emergency stop switch can be used.
memo-11 - memo-13	—
memo-14	Solenoid wiper can be used (available as an option).
memo-15	—
memo-16	Needle cooler output is enabled. (Needle cooler is available by special order.)
memo-17	Thread take-up device is not operated at the sewing end.
memo-18	Thread take-up device operates one stitch before the sewing end.
memo-19	Presser position errors are not detected.
memo-1A	Needle up stop position errors are not detected.
memo-1b	Presser can be moved up and down before the home position is detected. (Normally the presser cannot be moved up and down until after the home position has been detected.)
memo-1c	—
memo-1d	—
memo-1E	Errors can be reset using the EMERGENCY STOP switch. (EMERGENCY STOP switch is available as an option.)
memo-1F	Thread is not trimmed when an emergency stop occurs during sewing. (EMERGENCY STOP switch is available as an option.)

■ Memory switches 20 – 2F

Switch	Motion when set to ON
memo-20	Machine head from previous B430E series is used. (Only the operation panel and box are Mark II.)
memo-21	Rotating-type thread breakage detector operates. (Device is available by special order.)
memo-22	During thread breakage detection, sensitivity is decreased from 8 to 14 stitches at the sewing start. (Sensitivity during sewing is three stitches.)
memo-23	When DIP switch A-8 is simultaneously ON, setting values changed using the operation panel are ignored.
memo-24 - memo-2F	—

■ Memory switches 30 – 4F

30 to 4F are set by entering two-digit values.

These values are incremented using the P2 switch, and decremented using the P4 switch.

Switch	Possible setting range	Units	Initial value	Explanation
memo-30	0 - 30	mm	30	Limits the maximum area in the horizontal direction (X)
memo-31	0 - 30	mm	10	Limits the maximum area in the vertical direction (Y)
memo-32	12 - 27	× 100rpm	27	Changes the maximum sewing speed.
memo-33	1 - 10	× 7.5°	5	Changes the feed timing 1 (Fast) ← 5 (Standard) → 10 (Slow)
memo-34	0 - 5	Needle	0	The sewing speed at the sewing start is 400 rpm for the specified number of stitches.
memo-35	3 - 9	× 100rpm	4	Changes the sewing start speed specified by memo-34.
memo-36	—	—	—	—
memo-37	1 - 20	× 7.5°	10	Changes the feed timing one stitch before the sewing end. 1 (Fast) ← 10 (Standard) → 20 (Slow)
memo-38	1 - 20	× 7.5°	10	Changes the feed timing two stitches before the sewing end.
memo-39	1 - 20	× 7.5°	10	Changes the feed timing for the third stitch at the sewing start. 1 (Fast) ← 10 (Standard) → 20 (Slow)
memo-3A	1 - 20	× 7.5°	10	Changes the feed timing for the second stitch at the sewing start.
memo-3b	1 - 20	× 7.5°	10	Changes the feed timing for the first stitch at the sewing start.
memo-3c	—	—	—	—
memo-3d	—	—	—	—
memo-3E	—	—	—	—
memo-3F	—	—	—	—
memo-40 - memo-4F	—	—	—	—

10-7. Checking the input sensor and DIP switch input

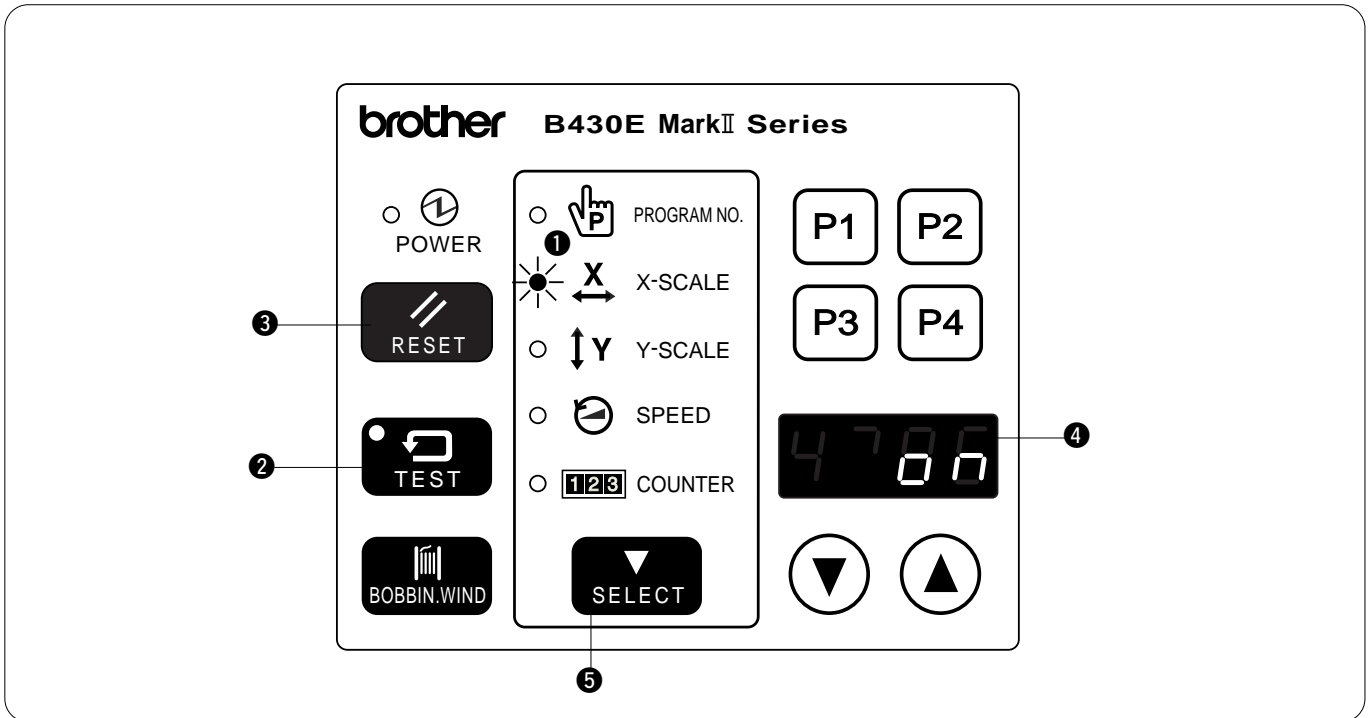

1. When the X-SCALE indicator ① is illuminated and the RESET switch ③ is pressed while the TEST switch ② is being pressed, the state of the X home position signal will appear on the display window ④.

• When sensor is ON



• When sensor is OFF



2. Each time the SELECT switch ⑤ is pressed, a different indicator will illuminate and the operating condition for the corresponding item will appear on the display window ④.

- When X-SCALE indicator is illuminated X home position sensor (ON when home position detected)
- When Y-SCALE indicator is illuminated Y home position sensor (ON when home position detected)
- When SPEED indicator is illuminated Synchronizer (*1)
- When COUNTER indicator is illuminated Presser sensor (ON when presser is lowered)

* 1) The synchronizer display simultaneously displays the needle up signal (3rd digit), the 24-section signal (2nd digit) and the needle down signal (1st digit).

[H L L] "H" when the sensor is on, and "L" when the sensor is off

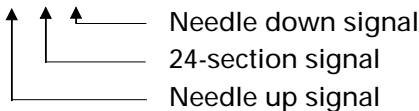

If the DIP switches at the side of the operation panel are changed at this time, the number of the DIP switch which was changed will be displayed in the 4th digit position of the display window ④ for about one second.

NOTE:

The DIP switch can be changed at this time without turning off the power so that you can check the DIP switch input. However, you should normally always turn off the power when changing DIP switch settings.

3. Press the TEST switch ② again to return the display to the normal condition.

10-8. Checking the input voltage

Specifications	Display	Notes
200V	[090 - 110]	"100" is displayed when the input voltage is 200V.
220V	[100 - 120]	
230V	[105 - 125]	
100V 380V 400V 415V	[100 - 120]	"110" is displayed when the input voltage is 100V (for 100-V specs.), 380V (for 380-V specs.) 400V (for 400-V specs.) or 415V (for 415-V specs.).

1. Turn on the power switch.
2. Press the SELECT switch ① until the Y-SCALE indicator ② illuminates.
3. While pressing the TEST switch ③, press the RESET switch ④.
4. If the input voltage is normal, the input voltage conditions will be shown in the display window ⑤ as indicated in the table above.
5. Press the TEST switch ③ again to return the display to the normal condition.

10-9. Clearing all memory settings

If the sewing machine stops operating normally, the cause may be that an incorrect memory setting may have been made by means of the memory switch, for instance. In such cases, carry out the following procedure to clear the memory, and also check the DIP switch settings.

[Method]

While pressing the RESET switch, turn on the power. This will clear all of the memory setting.

NOTE:

- This operation causes all settings stored in memory such as memory switch and user program settings to be cleared.
- If the optional emergency stop switch has been installed, you should reset memory switch No. 10 to ON.

10-10. Confirming software version

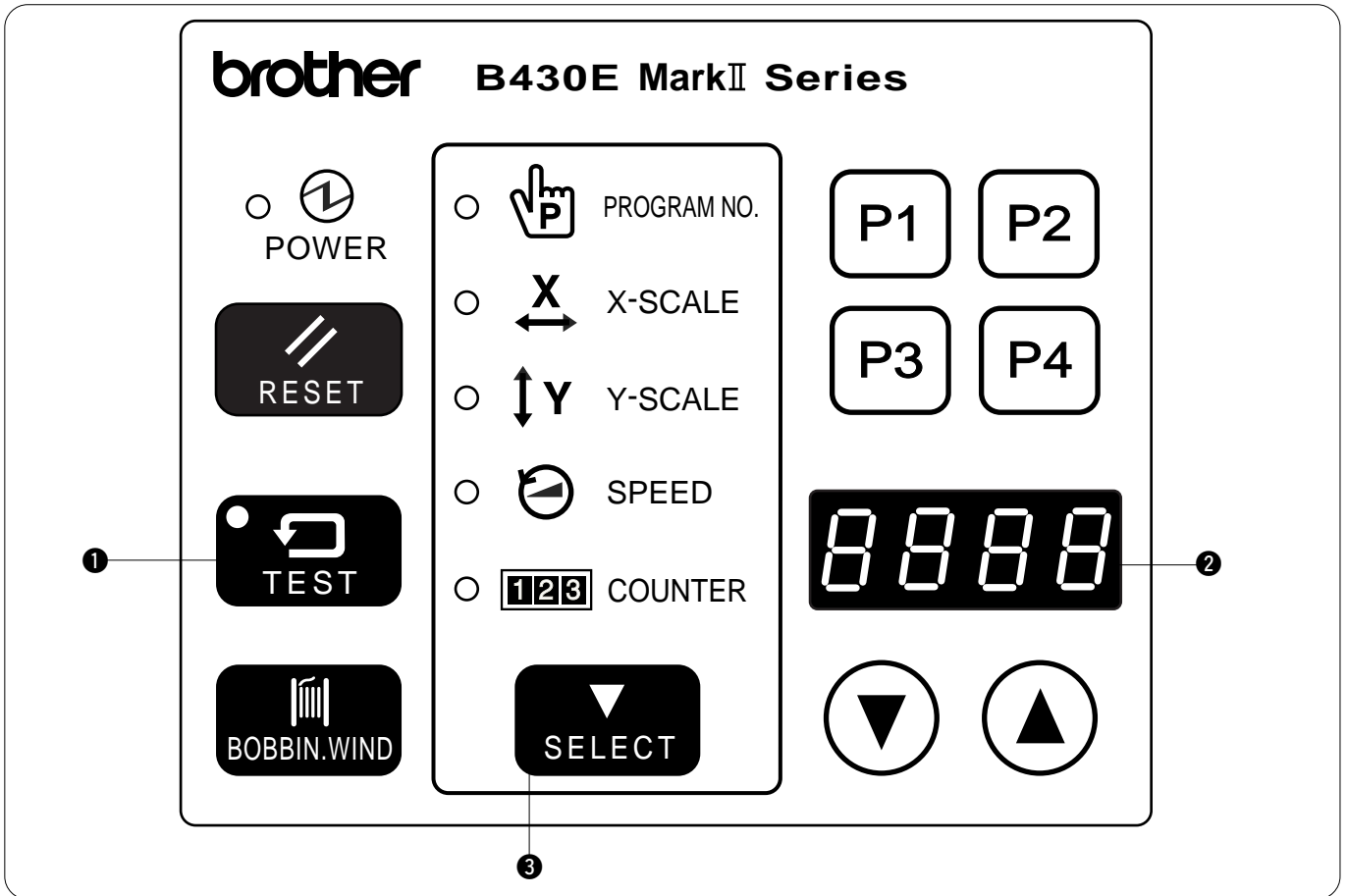

1. While pressing the TEST switch ①, turn on the power to the machine. Version number of each PROM can be confirmed in display ②.



3rd and 4th digits: Special specification
 2nd digit: Version number
 Versions A, B and C are replaced with 1, 2, and 3 respectively.
 1st digit: PROM identification code

2. Every time the SELECT switch ③ on the panel is pressed until the TEST switch ① is pressed again, the indication will change as follows:

Indication	LED of Menu switch	PROM
A (A)	X-SCALE	Main PROM(MN)
b (b)	Y-SCALE	Motor PROM(MT)

■ Version number indication (example)

PROM label

B430EMK2 MN-C Indication[A300]

B430EMK2 MT-D03 Indication[b403]

10. ELECTRIC MECHANISM

10-11. Table of error codes

⚠ DANGER



Wait at least 5 minutes after turning off the power switch and disconnecting the power cord from the wall outlet before opening the face plate of the control box. Touching areas where high voltages are present can result in severe injury.

If a malfunction should occur with the sewing machine, a buzzer will sound and an error code will appear in the display window.

Follow the remedy procedure to eliminate the cause of the problem.

Code	Cause	Remedy
E-13	Machine specification select connector is not connected properly.	Turn off the power and check if connectors P3 is disconnected.
E-20	Problem with machine motor stopping, or synchronizer connection error.	Turn off the power, and then turn the machine pulley to check if the machine has locked up. Check the synchronizer connection. Check if connectors P11, P12 and P13 are disconnected.
E-21	Machine motor operation error.	Turn off the power and check the ground wire connection.
E-30	Data is outside possible sewing area due to enlargement ratio setting.	Press the RESET switch, and then set the enlargement ratio again.
E-31	Stitch pattern data overlaps the sewing area when area limiting is active.	Press the RESET switch, and then reset the memory switches "30" and "31" or enlargement ratio.
E-32	The data format of the user program (% or mm) dose not match the setting of DIP switch A-6.	After changing the setting of DIP switch A-6, clear all memory settings.(Refer to "10-9. Clearing all memory settings.")
E-40	Length of a stitch exceeds 10 mm.	Press the RESET switch, and then set the enlargement ratio again.
E-41	Abnormality in the sewing data.	If programming a new sewing data, repeat the procedure from the beginning.
E-42	Invalid program number specified.	Press the RESET switch and specify a correct number.
E-50	Needle bar does not stop when the needle is raised.	Turn the pulley to align the index mark with the needle up stop position. (Refer to "6-17. Adjusting the needle up stop position".) Check the V-belt tension. (Refer to "6-18. Installing the V-belt".)
E-60	Presser has not been lowered.	Refer to "9. TROUBLESHOOTING". Turn off the power and check the connection of presser sensor connector P1.
E-61	Presser cannot be raised.	
E-62	Presser is not raised.	
E-63	Presser cannot be lowered.	
E-70	Cooling fan does not operate.	Turn off the power, and then check if the cooling fan is blocked with scraps of thread.
E-80	Motor PROM is not correctly inserted.	Turn off the power and check.
E-81	Foot switch was depressed when the power was turned on.	Turn off the power and check
E-82	An operation panel switch was depressed when the power was turned on.	Turn off the power and check the operation panel. Check that all panel cords are normal.
E-90	Abnormal drop in power supply voltage, or power was turned on again immediately after it was turned off.	Turn off the power and check the input voltage. After turning off the power, wait 3 seconds or more before turning it on again. (Refer to "10-8. Checking the input voltage".)
E-91	Abnormal rise in power supply voltage.	Turn off the power and check the input voltage. (Refer to "10-12. Checking the input voltage".)

Code	Cause	Remedy
E-A0	Home position cannot be detected (malfunction of home position sensor), or malfunction of power supply circuit board.	Turn off the power and check the connection of home position sensor connector P1.
E-b0	You tried to change the program number when DIP switch A-8 was set to ON.	Press the RESET switch. Set DIP switch A-8 to OFF before trying to change the program number.
E-d0	Heat sink of control circuit board is abnormally hot.	Turn off the power and clean the air intake port of the box.
E-E0	Malfunction of EEPROM (malfunction of main circuit board).	Turn off the power, and turn it back on. If the error continually occurs, contact a qualified service technician.
E-E1	Corrupted EEPROM data, or main PROM version has been upgraded.	Press the RESET switch to reset the error. However, the data (memory switches, display and user programs) will be reset to the backup data or initialized.
E-E2	Corrupted EEPROM control information data	Press the RESET switch to reset the error. However, the data (memory switches, display and user programs) will be initialized.
E-F0	Solenoid short-circuit (malfunction of main circuit board), or power relay is not operating (malfunction of power supply circuit board).	Turn off the power and contact a qualified service technician.
E-F1	Bad connection in cable between power supply circuit board and main circuit board.	Turn off the power and check if connectors P16 is disconnected.
E-F2	Abnormal current detected in power supply circuit board.	Turn off the power and contact a qualified service technician.

■ Errors generated when optional equipment is connected

Code	Cause	Remedy
E-10	Emergency stop switch was pressed.	Turn the EMERGENCY STOP switch clockwise to release the lock, and then press the RESET switch to reset the error.
E-11	Emergency stop switch was pressed during sewing.	Turn the EMERGENCY STOP switch clockwise to release the lock, and then press the RESET switch to reset the error. You can then press the STEP BACK switch to repeat the sewing.
E-12	Emergency stop switch is being continually pressed, or emergency switch connection error.	Turn off the power and check.
E-14	Thread breakage detected.	Turn the EMERGENCY STOP switch clockwise to release the lock, and then press the RESET switch to reset the error. You can then press the STEP BACK switch to repeat the sewing.

REFERENCE segment LED alphabet

	Panel display	<i>A</i>	<i>b</i>	<i>c</i>	<i>d</i>	<i>E</i>	<i>F</i>	<i>6</i>	<i>H</i>	<i>L</i>	<i>o</i>
	Text display	A	b	c	d	E	F	6	H	L	O

10-12. Troubleshooting flowchart

10-12-1. Troubleshooting flowchart

Symbols and their meanings

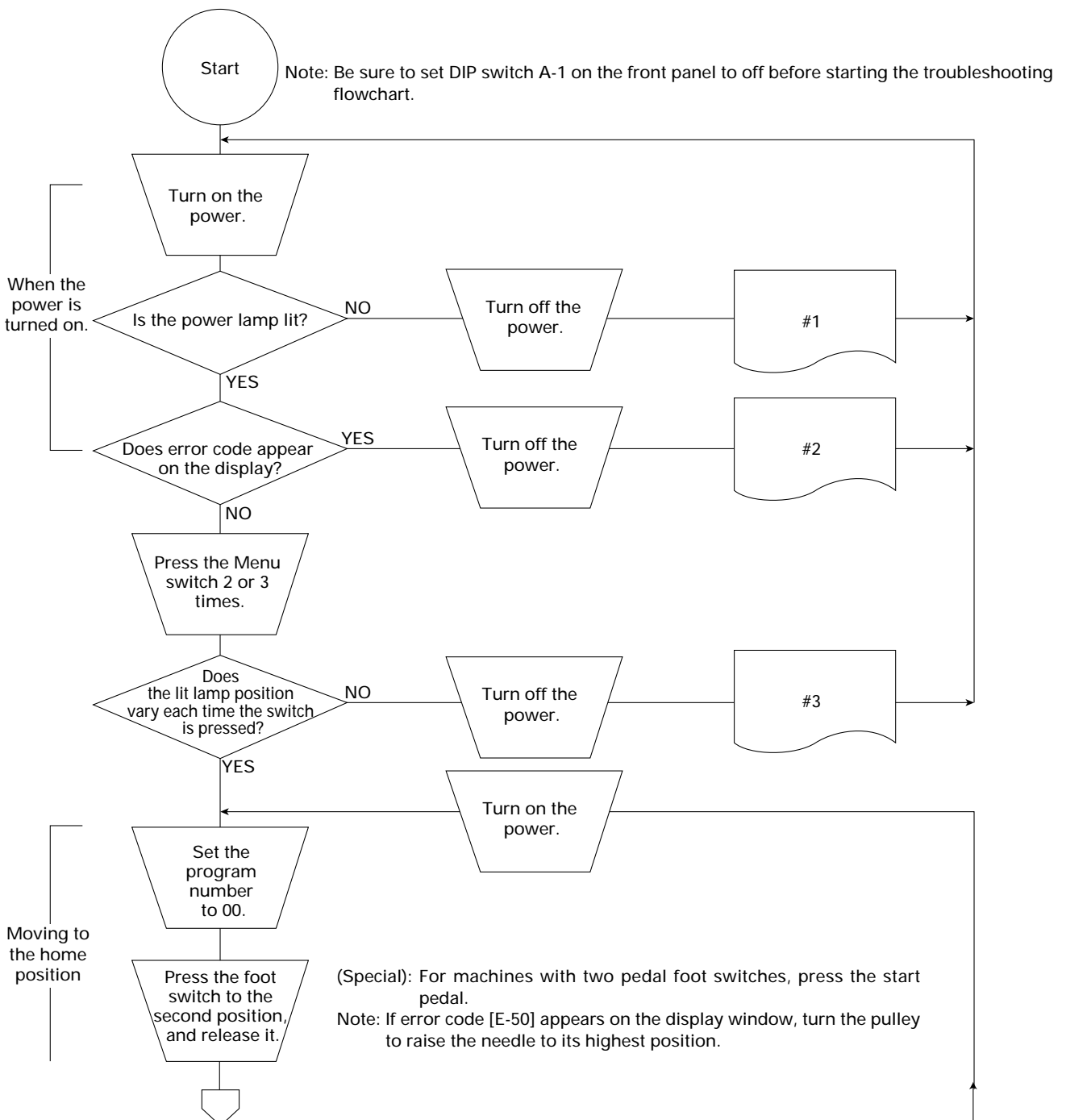
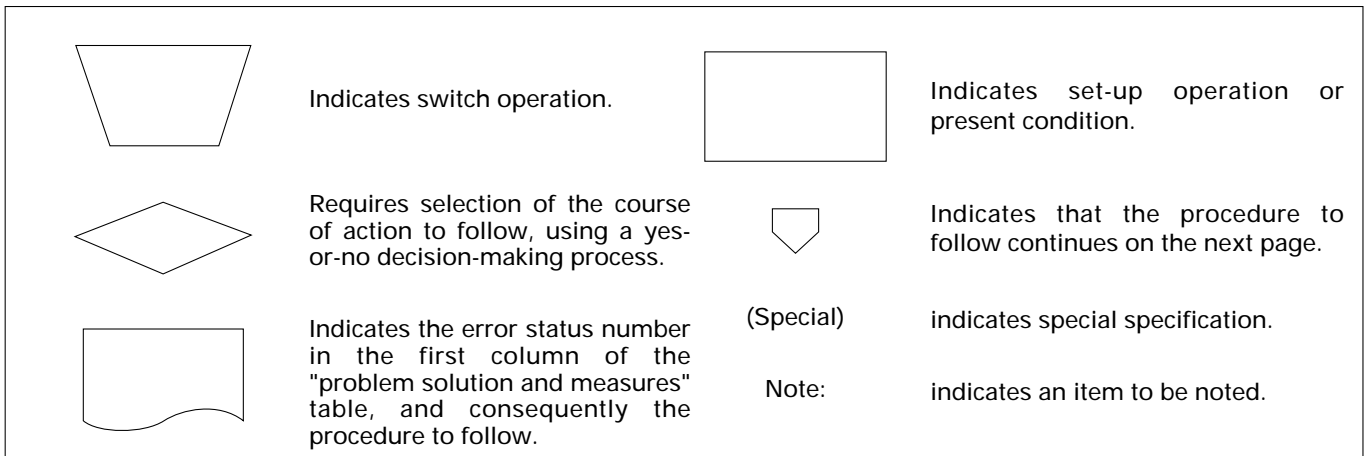

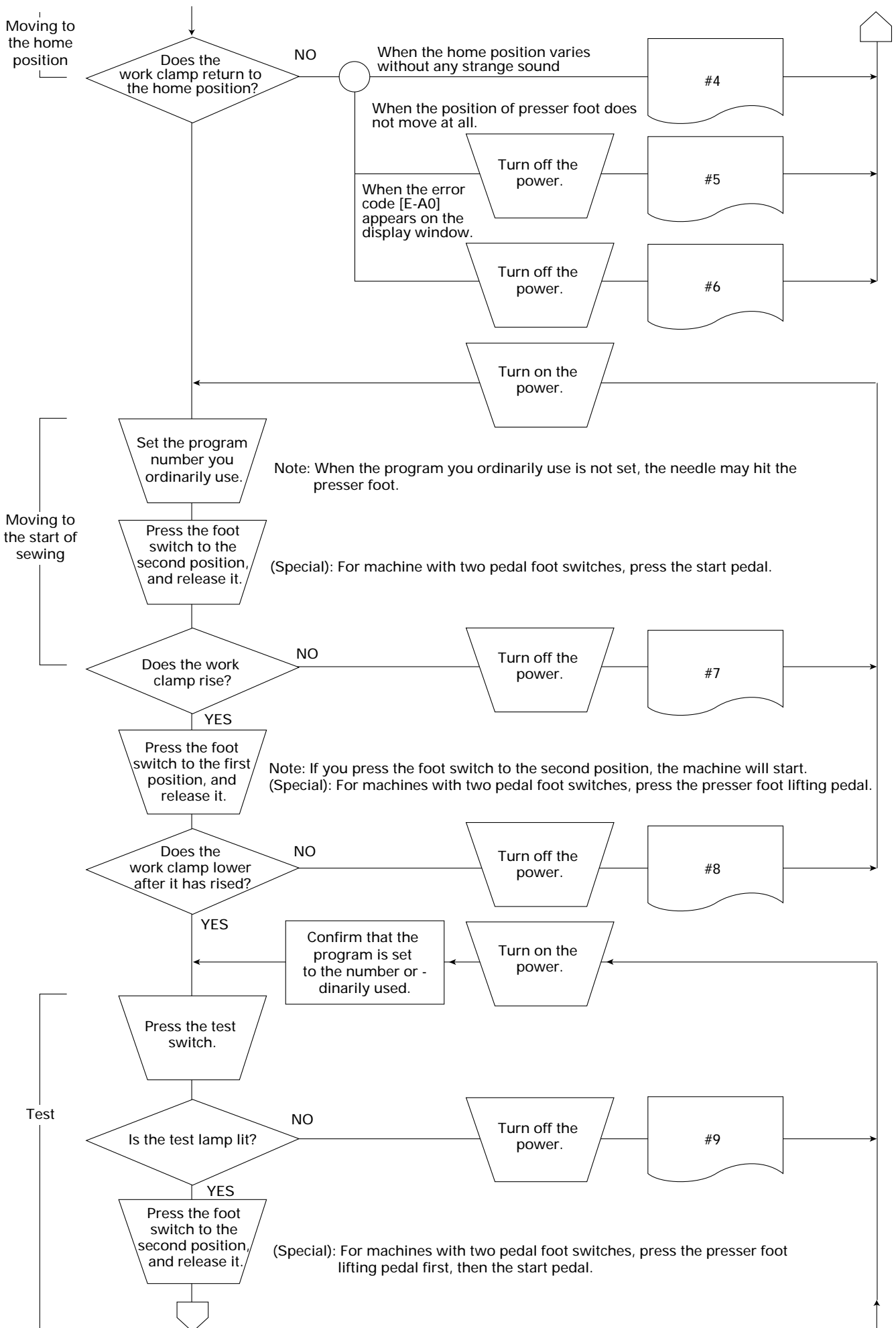

10. ELECTRIC MECHANISM

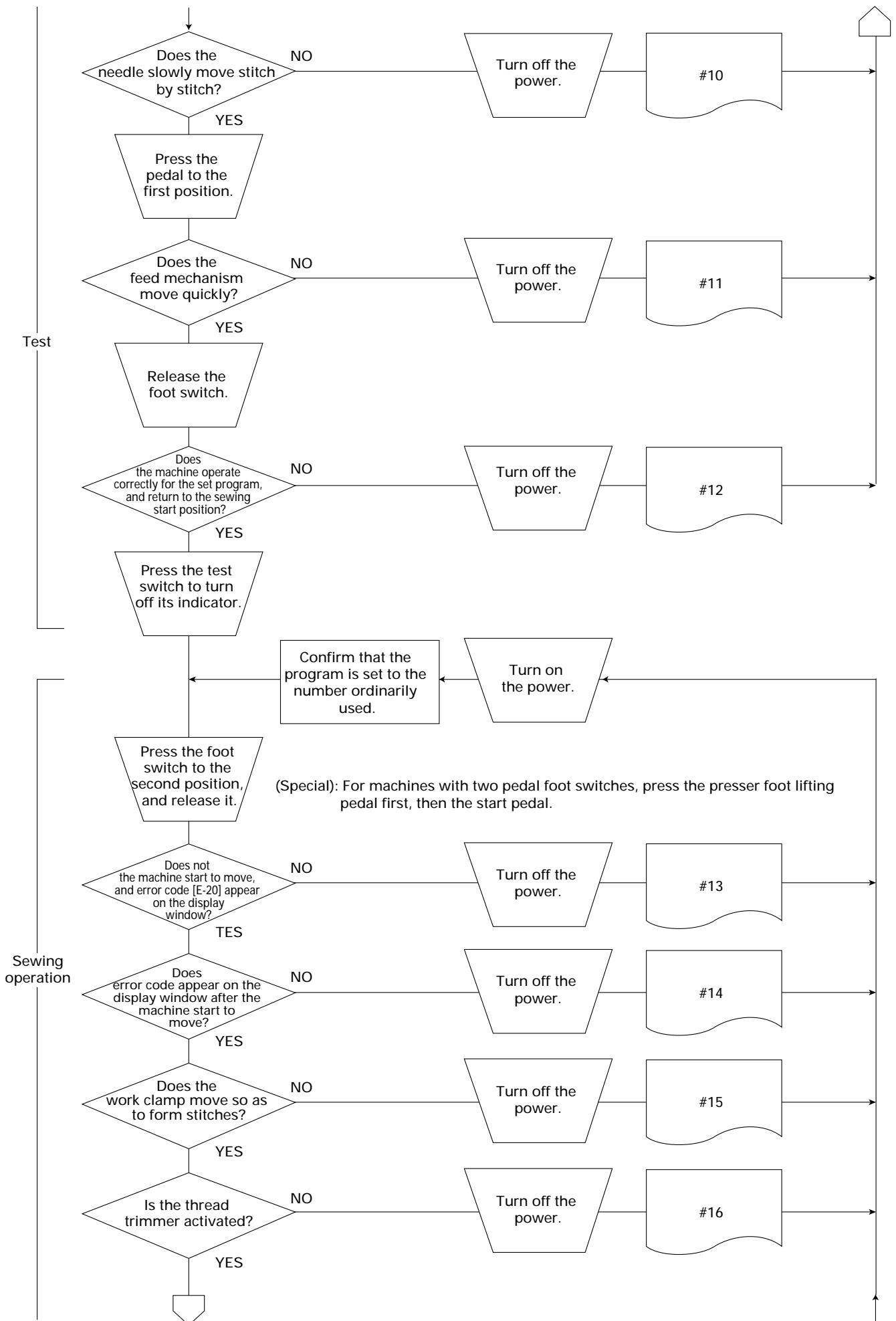

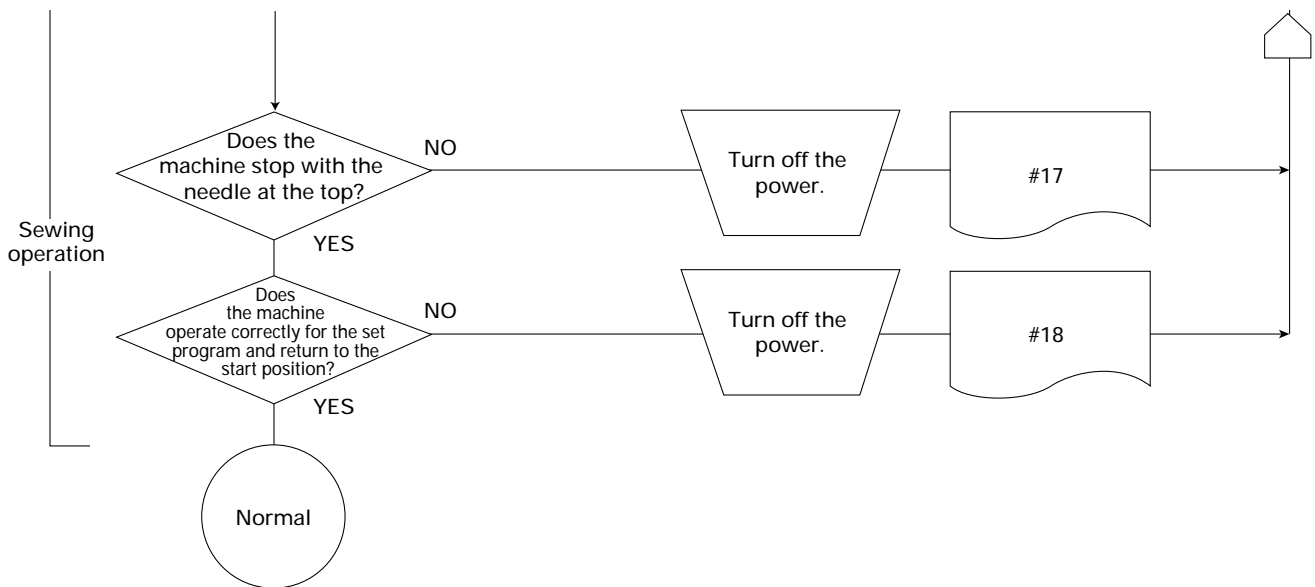

10-12-2. Problem solution and measures

Precautions

1. Pay attention to the following when opening the control box for maintenance.

■ Electrical shock

Some large capacitors may have a high voltage remaining in them for up to 5 minutes after the power is turned off. To prevent electrical shock, wait at least 5 minutes after the power is turned off before doing the following:

- Opening and closing the control box
- Replacing fuses
- Separating and rejoining connectors
- Measuring resistance
- Doing anything with a possibility of touching something inside the control box

Some adjustments require measuring the voltage while the power is turned on with the control box kept open.

In such a case, be careful not to touch any place other than that for the measurement. In addition, always keep in mind that a high voltage remains for 5 minutes after the power is turned off.

■ Injury

While the power is turned on, the DC fan motor of the control box operates; be careful not to get caught in it.

When separating or rejoining connectors, and measuring something, be careful not to cut your fingers on metal parts such as the heatsinks and covers.

2. When replacing a fuse, be sure to use a new one of the same quality and capacity as the old one.

3. Refer to the circuit block diagram at the end of this manual regarding the connector numbers and their matches.

Before adjustment

1. While the power is turned off, check each connector is securely plugged in by referring to page 63, "List of connector numbers and matches."

2. Find the error status number in the troubleshooting flowchart.

3. From the applicable part of the flowchart, take the reference number to find the correspondingly numbered details of the problem in the following table.

10. ELECTRIC MECHANISM

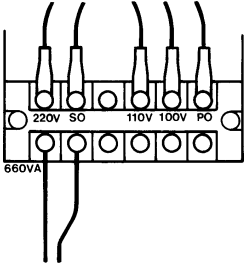
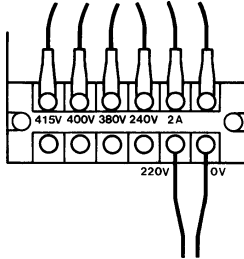
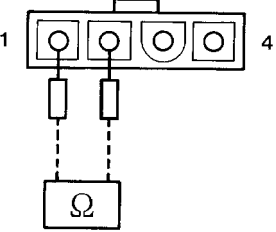
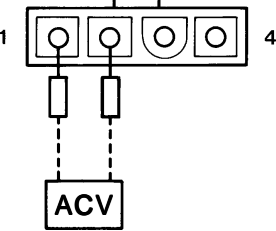
Error status	Probable causes	Check/repair/adjust	Parts to be replaced				
<p>#1</p> <p>The power lamp does not light when the power is turned on.</p>	<p>1. Conversion transformer improperly wired (for 100V specification)</p>  <p>(For 380 V, 400V, and 415 V specifications)</p>  <p>(For 200 V, 220 V, and 230 V specifications) No conversion transformer is installed.</p>	<p>Note: Before adjustment, be sure to check that the power is turned off to prevent electric shock. If the power is turned on, turn off the power, and wait at least 5 minutes.</p> <p>a. Conversion in the control box Check the transformer is correctly and securely wired to the terminals.</p> <p>(For 200 V, 220 V, and 230 V specifications, this is not necessary.)</p>					
	<p>2. Conversion transformer defective</p> 	<p>Separate P4 (ACIN) connectors on the power supply circuit board, and check there is continuity between pins 1 and 2 in the connector on the cable. If there is no continuity, replace the conversion transformer. (For 200 V, 220 V, and 230 V specifications, this is not necessary.)</p>	Conversion transformer				
	<p>3. Power supply cable defective</p> 	<p>Separate P4 (ACIN) connectors on the power supply circuit board, turn on the power, and measure the voltage across pins 1 and 2 in the connector on the cable. If the voltage is as shown in the table below, the power supply cable is not defective.</p> <table border="1" data-bbox="699 1659 1214 1839"> <tbody> <tr> <td>For 200 V, 220 V, and 230 V specifications</td> <td>The same as the power supply voltage of wall socket</td> </tr> <tr> <td>For 100 V, 110 V, 240 V, 380 V, 400 V, and 415 V specifications</td> <td>About 220 V</td> </tr> </tbody> </table> <p>After checking, turn off the power, and rejoin P4 connectors.</p>	For 200 V, 220 V, and 230 V specifications	The same as the power supply voltage of wall socket	For 100 V, 110 V, 240 V, 380 V, 400 V, and 415 V specifications	About 220 V	Power supply cable
For 200 V, 220 V, and 230 V specifications	The same as the power supply voltage of wall socket						
For 100 V, 110 V, 240 V, 380 V, 400 V, and 415 V specifications	About 220 V						

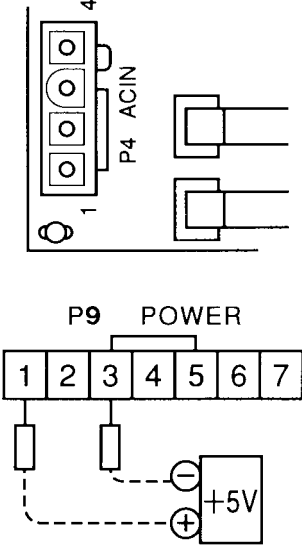
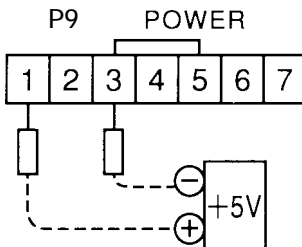
Error status	Probable causes	Check/repair/adjust	Parts to be replaced
<p>#1</p> <p>The power lamp does not light when the power is turned on.</p>	<p>4. Fuse has blown</p>	<p>a. Remove fuses No.3 and No.4, and check them for continuity.</p> <p>If there is no continuity, replace the fuses with new ones, and perform the check/repair/adjust items of #1-5.</p>	<p>Fuse 6A-250V</p>
	<p>5. Power supply circuit board defective</p> 	<p>a. Separate P4 (ACIN) connectors on the power supply circuit board, and then measure the resistance between the following pairs of pins, pins 1 and 4 and pins 2 and 4, in the connector on the cable.</p> <p>If the resistance is $\infty\Omega$ in both cases, the power supply circuit board is not defective.</p> <p>b. Measure the resistance between pins 1 and 2.</p> <p>If there is no short, the power supply circuit board is not defective.</p> <p>c. Rejoin P4 (ACIN) connectors on the power supply circuit board.</p> <p>Separate P9 (POWER) connectors on the main circuit board, turn on the power, and measure the voltage across pins 1 and 3 in the connector on the cable.</p> <p>If it is + 5V, the power circuit board is not defective.</p> <p>After measurement, turn off the power, wait at least 5 minutes, and then rejoin P9 connectors.</p>	<p>Power supply circuit board</p>
	<p>6. Main circuit board defective</p> 	<p>With P9 (POWER) connectors plugged in on the main circuit board, turn on the power, and measure the voltage across pins 1 and 3 in the connector on the cable.</p> <p>If it is + 5V, the power circuit board is not defective.</p> <p>After measurement, turn off the power.</p>	<p>Main circuit board</p>
<p>7. Panel circuit board defective</p>	<p>Check that P8 (PANEL) connectors of the main circuit board and P1 (PANEL) connectors of the panel circuit board are plugged in.</p>	<p>Panel circuit board panel cord</p>	

10. ELECTRIC MECHANISM

Error status	Probable causes	Check/repair/adjust	Parts to be replaced
#2 Error code appears on the display window when the power is turned on.	1. Cooling fan defective when the error code E-70 appears on the display window.	<ul style="list-style-type: none"> a. Check threads are not tangled in the cooling fan. b. Check P10 (FAN) connectors are securely plugged in on the main circuit board. 	DC fan motor assy
	2. PROM chip defective or main circuit board defective when the error code E-80 appears on the display window.	<ul style="list-style-type: none"> a. Check the PROM chip is securely attached to the main circuit board without its lead bent. b. Check the PROM chip is attached to the main circuit board with letters MN and MT on the PROM chip and those on the main circuit board matching. 	PROM chip Main circuit board
	3. Foot switch remains pressed when error code E-81 appears on the display window.	See #5-1 and #5-2.	Foot switch Foot switch cord assy
	4. A switch on operation panel remains pressed when error code E-82 appears on the display window.	See #1-7.	Panel PCB Panel cord
	5. Power supply voltage drops abnormally when error code E-90 appears on the display window.	<ul style="list-style-type: none"> a. Make sure that the power supply voltage of the wall socket is within $\pm 10\%$ of the voltage specification. b. See # 1-2 and #1-3. 	
	6. Power supply voltage rises abnormally when error code E-91 appears on the display window.	See #2-5.	
	7. Control box has overheated when the error code E-d0 appears on the display window.	<ul style="list-style-type: none"> a. Clean the ventilation outlet of the control box. b. Keep the control box open for a while to allow the inside to cool down, and then turn on the power again. If the same code still appears on the display, the main circuit board is defective. 	Main circuit board
	8. Main circuit board defective	Turn on the power again. If the same code still appears on the display, the main circuit board is defective.	Main circuit board
	9. Cord defective when the error code E-F1 appears on the display window.	Check P2 (PER) connectors are attached to the power supply circuit board and P16 (PER) connectors are attached to the main circuit board. Check the cord connecting P2 and P16 is not damaged.	PER cord
	10. Short circuit in a solenoid (main circuit board defective) occurs or relay on the power supply circuit board does not function when error code E-F0 appears on the display window.	<ul style="list-style-type: none"> a. See #7-2. b. See #16-2. c. Power supply circuit board is defective if the error still appears after replacement of the main circuit board. 	Sewing clamp solenoid and Main circuit board Thread trimming solenoid and main circuit board Main circuit board and power supply circuit board
	11. Abnormal electricity supply is detected when error code E-F2 appears on the display window.	Power supply circuit board defective if the error still appears after replacement of the main circuit board.	Main circuit board and power supply circuit board

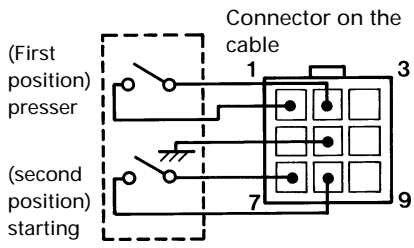
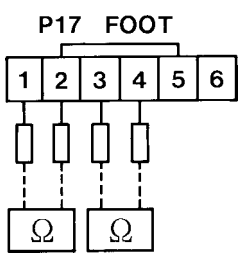
Error status	Probable causes	Check/repair/adjust	Parts to be replaced
#3 No switches on the operation panel are activated.	1. Panel PCB defective	See #1-7.	Panel PCB Panel cord
#4 Home position is not correct.	1. Home position sensor not adjusted properly	Look the status of home position signals referring to page 49. When both X- and Y-home position signal lamps are lit, adjust the home position while referring to page 49. When either signal lamp is not lit, perform the check/repair/adjust items of #6.	
#5 Work clamp does not return to the home position even after the foot switch is pressed.	1. Foot switch and its cord are defective 	(Make sure that the power is turned off. If you proceed from #4, be sure to turn off the power.) Remove the foot switch connector from the outside of the control box, and check it for continuity between the following pairs of pins, pins 1 and 2 and pins 7 and 8, in the connector on the cable: If it is normally $\infty\Omega$, 0Ω between pins 1 and 2 when pressing the foot switch to the first position, or 0Ω between pins 1 and 2 and pins 7 and 8 when pressing the foot switch to the second position, the foot switch and its cord are not defective.	Foot switch
	2. Cord in the control box is defective 	Rejoin the connector checked in #5-1. Open the control box, and check P17 (FOOT) connectors for continuity between the following pairs of pins, pins 1 and 2 and pins 3 and 4, in the connector on the main circuit board. (Do not separate P17 connectors. Make sure the tester probes touch the leads.) If it is normally $\infty\Omega$, 0Ω between pins 3 and 4 when pressing the foot switch to the first position, or 0Ω between pins 1 and 2 and pins 3 and 4 when pressing the foot switch to the second position, the cord is not defective.	Foot switch cord assy
#6 Error code appears on the display window when the foot switch is	1. Fuse has blown when the feed mechanism does not move and error code E-A0 appears on the display window.	Remove fuse No.1 and check it for continuity. If there is no continuity, the fuse is defective. Proceed to #6-2.	Fuse 5A-250V

10. ELECTRIC MECHANISM

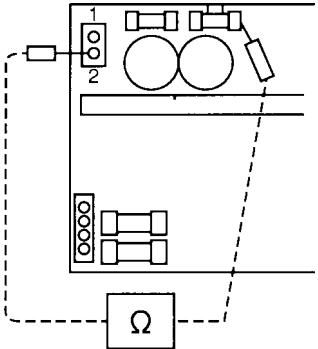
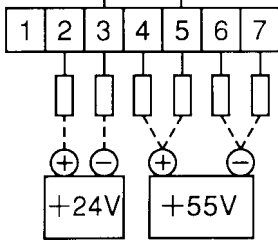
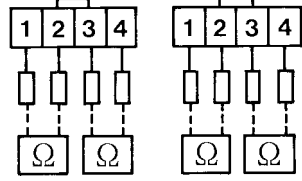
Error status	Pdrobable causes	Check/repair/adjust	Parts to be replaced
<p>#6 Error code appears on the display when the foot switch is pressed.</p>	<p>2. Power supply circuit board is defective when the feed mechanism does not move and error code E-A0 appears on the display window.</p>  <p style="text-align: center;">P9 POWER</p> 	<p>a. Measure the resistance between the fuse No.1 terminal which is close to the center of the power supply circuit board and pin 2 of P5 (DC300) connector. If the resistance is $\infty\Omega$, the power supply circuit board is not defective.</p> <p>b. Separate P9 (POWER) connectors on the main circuit board, turn on the power, and measure the voltage across the following pairs of pins, pins 4 and 6 and pins 5 and 7, in the connector on the cable. If the voltage is +55V in each case, the power supply circuit board is not defective. After measurement, turn off the power, wait at least 5 minutes, and rejoin P9 connectors.</p>	<p>Power supply circuit board</p>
	<p>3. Home position sensor is defective when the work clamp moves in an unexpected direction and error code E-A0 appears on the display window.</p>	<p>a. Turn the power switch off and then on again, and move the work clamp to near the home position by hand. If the home position sensor LED is lit, the home position sensor is not defective.</p> <p>b. Check that P1 (ORG) connector on the main circuit board and the home position sensor are plugged in.</p> <p>c. See 10-7. "Checking the input sensor and DIP switch input" to make sure that the home position sensor is connected. If item a causes no problem and item b results in defective sensor input, either the cord connection is poor or the main circuit board is defective.</p>	<p>Home position sensor</p> <p>Main circuit board</p>
	<p>4. Pulse motor and cord are defective when the work clamp operates abnormally and error code E-A0 appears on the display window.</p> <p style="text-align: center;">P6 YPM P7 XPM</p> 	<p>a. Separate P6 (YPM) and P7 (XPM) connectors on the main circuit board. Measure the resistance between the following pairs of pins, pins 4 and 6 and pins 5 and 7, in the connector on the cable. If the resistance is 2 - 3 Ω, it is not defective. After measurement, rejoin P6 and P7 connectors.</p> <p>b. If item b causes no problem, the main circuit board is defective.</p>	<p>X- or Y-pulse motor assy</p> <p>Main circuit board</p>

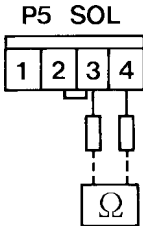
Error status	Probable causes	Check/repair/adjust	Parts to be replaced
<p>#7</p> <p>Work clamp does not rise.</p>	<p>1. Work clamp is not lowered when error code E-60 appears on the display window.</p>	<p>a. If it is not lowered due to the mechanical lock, see 6-14 "Adjusting the positions of the presser solenoid" for adjustment.</p> <p>b. Open the top cover, turn on the power switch, and press the tip of the plunger of the presser solenoid. If the work clamp sensor LED is turned on and off, it is OK.</p> <p>c. Make sure P1 (ORG) connector on the main circuit board and work clamp sensor are plugged in.</p> <p>d. See 10-7. "Checking the input sensor and DIP switch input" to make sure that the work clamp sensor is connected. If item b causes no problem and item c results in defective sensor input, either the cord connection is poor or the main circuit board is defective.</p>	<p>Sewing clamp sensor</p> <p>Main circuit board</p>
	<p>2. Work clamp is not raised although attempted, when no error code appears or error code E-61 appears on the display window.</p> <ul style="list-style-type: none"> Presser bar lifter solenoid defective 	<p>a. If it does not rise because of mechanical problem, see 6-14 "Adjusting the positions of the presser solenoid."</p> <p>b. Separate P5 (SOL) connectors on the main circuit board, and measure the resistance between pins 3 and 4 in the connector on the cable. If the resistance is 2 - 3 ohms, there is no problem. After measurement, rejoin P5 connectors. If the resistance is 0 ohms (it means a short circuit), replace the main circuit board with a new one because it may be defective.</p> <p>c. If the presser bar lifter solenoid does not operate at all, the main circuit board is defective.</p>	<p>Sewing clamp solenoid</p> <p>Main circuit board</p> <p>Main circuit board</p>
<p>#8</p> <p>Work clamp does not lower.</p>	<p>1. Work clamp is not raised when error code E-62 appears on the display window.</p>	<p>Same as #7-2.</p>	
	<p>2. Work clamp is not lowered although attempted when error code E-63 appears on the display window.</p>	<p>Same as #7-1.</p>	

10. ELECTRIC MECHANISM

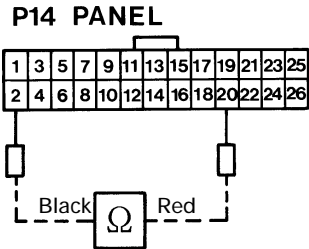
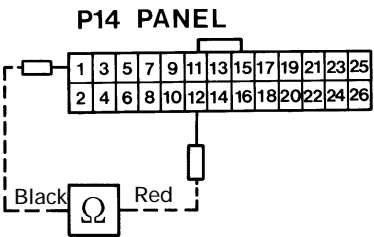
Error status	Probable causes	Check/repair/adjust	Parts to be replaced
<p>#9</p> <p>The test lamp does not light when the test switch is pressed.</p>	<p>1. Test switch and its cord are defective</p>  <p>P14 PANEL</p> <p>1 3 5 7 9 11 13 15 17 19 21 23 25 2 4 6 8 10 12 14 16 18 20 22 24 26</p> <p>Black Ω Red</p>	<p>Separate P14 (PANEL) connectors on the main circuit board, and measure the resistance between pins 2 and 20 in the connector on the cable with the polarity shown in the left figure.</p> <p>(Use of a digital meter is prohibited.)</p> <p>If the resistance is normally $\infty\Omega$, or the needle oscillates at its maximum limits when the test switch is pressed, the test lamp and its cord are not defective.</p>	Panel PCB or panel cable assy
	<p>2. Test lamp and its cord are defective</p>  <p>P14 PANEL</p> <p>1 3 5 7 9 11 13 15 17 19 21 23 25 2 4 6 8 10 12 14 16 18 20 22 24 26</p> <p>Black Ω Red</p>	<p>Measure the resistance between pins 1 and 12 with the same method as for #9-1.</p> <p>If the needle oscillates at its maximum limits, the test lamp and its cord are not defective.</p>	Panel PCB or panel cable assy
	<p>3. Main circuit board defective</p>		
<p>#10</p> <p>The feed mechanism does not move during test.</p>		<p>a. See #5.</p> <p>b. See #6.</p>	
<p>#11</p> <p>Quick feeding cannot be performed during test.</p>		See #5.	
<p>#12</p> <p>The machine does not operate correctly for the set program during test sewing.</p>		<p>See #5.</p> <p>See #6.</p>	

Error status	Probable causes	Check/repair/adjust	Parts to be replaced
<p>#13</p> <p>The machine does not operate during sewing, and the error code E-20 appears on the display window.</p>	<p>1. Cable related to machine motor is defective</p>	<p>a. Make sure P3 (DC18) connector on the power supply circuit board and P13 (DC18) on the main circuit board are plugged in.</p> <p>b. Make sure P5 (DC300) connector on the power supply circuit board and P12 (DC300) connector on the main circuit board are plugged in.</p> <p>c. Check the connection between P11 (UVW) connector on the main circuit board and the terminal block of the machine motor.</p>	<p>Gate power supply cable</p> <p>Motor power supply cable</p> <p>Motor cable</p>
	<p>2. Main circuit board is defective when fuse F1 on the main circuit board has blown.</p>	<p>Replace the main circuit board with a new one when fuse F1 has blown.</p>	<p>Main circuit board</p>
	<p>3. Main circuit board defective</p> <div style="text-align: center;"> <p>The diagram shows a connector labeled 'P12 DC300' with two terminals, '1' and '2'. Terminal '1' is connected to a red wire, and terminal '2' is connected to a black wire. These wires are connected to a square symbol representing an ohm meter (Ω). The red wire is labeled 'Red' and the black wire is labeled 'Black'.</p> </div>	<p>Separate P12 (DC300) connectors on the main circuit board, and measure the resistance between pins 1 and 2 in the connector on the main circuit board with the same polarity as shown in the left figure.</p> <p>(Use of a digital meter is prohibited.)</p> <p>If the pointer indicates 10KΩ - 30k Ω on the x 1k Ω range, the main circuit board is not defective.</p> <p>After measurement, rejoin P12 connectors.</p> <p>(If the pointer does not, fuses No.2, 3, and 4 may be blown. Examine them.)</p>	<p>Main circuit board</p>
<p>#14</p> <p>Error code appears on the display window after the machine operates.</p>	<p>1. Synchronizer is defective or machine is not adjusted properly when error code E-20 appears on the display window after the machine is started.</p>	<p>a. Make sure that P2 (SYNCHRO) connector on the main circuit board and the synchronizer are plugged in.</p> <p>b. See 10-7. "Checking the input sensor and DIP switch input" to make sure that the synchronizer is connected.</p> <p>If signal is switched on and off, there is no problem.</p> <p>c. Turn the pulley by hand to check it can easily rotate.</p> <p>d. If error code E-20 appears when the machine is stopped, see 6-12. "Adjusting the thread trimming solenoid position" for adjustment.</p>	<p>Synchronizer assy</p>
	<p>2. A malfunction occurs due to noise or main PROM is defective when error code E-21 appears after the machine is started.</p>	<p>a. Make sure that the ground wire is surely grounded and there is no equipment that generates strong electrical noise in the vicinity.</p> <p>b. If the machine has been remodeled, return the machine to its original condition before checking.</p> <p>c. If the error still occurs after replacement of PROM, put the original PROM back before checking.</p>	<p>PROM chip</p>
	<p>3. Power supply voltage abnormally lowers when error code E-90 appears after the machine is started.</p>	<p>See #2-5.</p> <p>If 550VA /machine is not allocated at the power source, the voltage will drop as soon as the machine is started, resulting in this error.</p>	

10. ELECTRIC MECHANISM

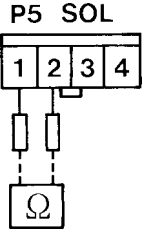
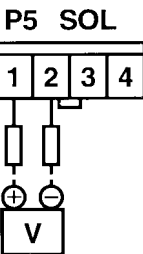
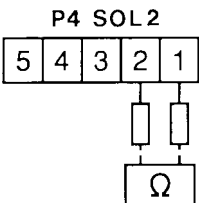
Error status	Probable causes	Check/repair/adjust	Parts to be replaced
#15 The machine cannot produce correct stitches.	1. Synchronizer defective	See #14-1.	
	2. Pulse motor is defective or mechanical adjustment is not appropriate when stitching deviates from what it should be.	a. See #6-4. b. If stitching deviates because of insufficient pressure of the work clamp, see 6-6. "Adjusting the work clamp lift amount" for adjustment. c. Make adjustments if the feed mechanism has any unnecessary looseness.	
#16 The thread trimmer does not operate.	1. Home position sensor not adjusted properly	Adjust the thread trimmer mechanism (page 24 and 36). (When it is obvious that the thread trimmer does not operate, perform the check/repair/adjust items of #16-2 and #16-3.)	
	2. Thread trimmer solenoid defective  <p>The diagram shows a 4-pin connector labeled 'P5 SOL' with pins numbered 1, 2, 3, and 4. Pins 1 and 2 are connected to a solenoid, represented by a rectangle with a diagonal line. A resistor symbol (Ω) is connected across the solenoid terminals to measure resistance.</p>	Separate P5 (SOL) connectors on the main circuit board, and then measure the resistance between pins 1 and 2 in the connector on the cable. If the resistance is 7 - 8 Ω, the solenoid is not defective.	Thread trimmer solenoid
	3. Main circuit board defective  <p>The diagram shows a 4-pin connector labeled 'P5 SOL' with pins numbered 1, 2, 3, and 4. Pins 1 and 2 are connected to a voltage measurement point. A voltmeter symbol (V) is connected across pins 1 and 2. Below the voltmeter is the label 'Thread trimmer'.</p>	With P5 (SOL) connectors plugged in on the main circuit board, turn on the power, perform sewing, and measure the voltage across pins 1 and 2 in the connector on the cable. If there is a sudden voltage output at the end of sewing, it is OK.	Main circuit board
#17 Thread take-up lever does not operate.	1. Home position sensor not adjusted properly	Adjust the thread take-up mechanism (page 27). (If the solenoid does not work even after it is separated from the mechanical parts, perform the following items #17-2 and #17-3.)	
	2. Thread take-up solenoid defective  <p>The diagram shows a 5-pin connector labeled 'P4 SOL2' with pins numbered 5, 4, 3, 2, and 1 from left to right. Pins 2 and 1 are connected to a solenoid, represented by a rectangle with a diagonal line. A resistor symbol (Ω) is connected across the solenoid terminals to measure resistance.</p>	Separate P4 (SOL2) connectors on the main circuit board, and then measure the resistance between pins 1 and 2 in the connector on the cable. If the resistance is 12 - 14 Ω, the solenoid is not defective.	

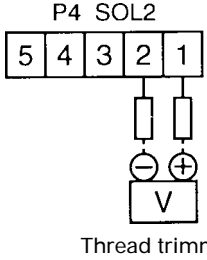
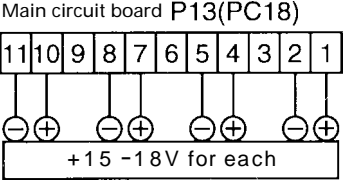
Error status	Probable causes	Check/repair/adjust	Parts to be replaced
#17 Thread take-up lever does not operate.	3. Main circuit board defective  <p style="text-align: center;">Thread trimmer</p>	With connector P4 (SOL2) on the main circuit board removed, turn on the power, perform sewing, and measure the voltage across pins 1 and 2 of connector P4. If there is a sudden voltage output at the end of sewing, it is OK.	
#18 The machine does not stop with the needle at the upper position after thread trimming (Error code E-50 appears on the display window).	1. Poor adjustment	a. See 6-17. "Adjusting the needle up stop position," and 6-18. "Adjusting the V-belt tension" for adjustment. b. If the pulley turns after the machine stops, this is not an electrical problem.	V-belt
	2. Synchronizer defective	See #14-1.	
	3. Cable defective	See #13-1.	
	4. Power supply circuit board defective  <p style="text-align: center;">+15 -18V for each</p>	With P13 (DC18) connectors plugged in on the main circuit board, measure the voltage in the connector on the cable. If the voltage across the following pairs of pins, pins 1 and 2, pins 4 and 5, and pins 10 and 11 is DC 15 - 18 V, it is OK.	Power supply circuit board
	5. Main circuit board defective		Main circuit board
	6. Motor defective		Motor

10-13. Control circuit block diagram

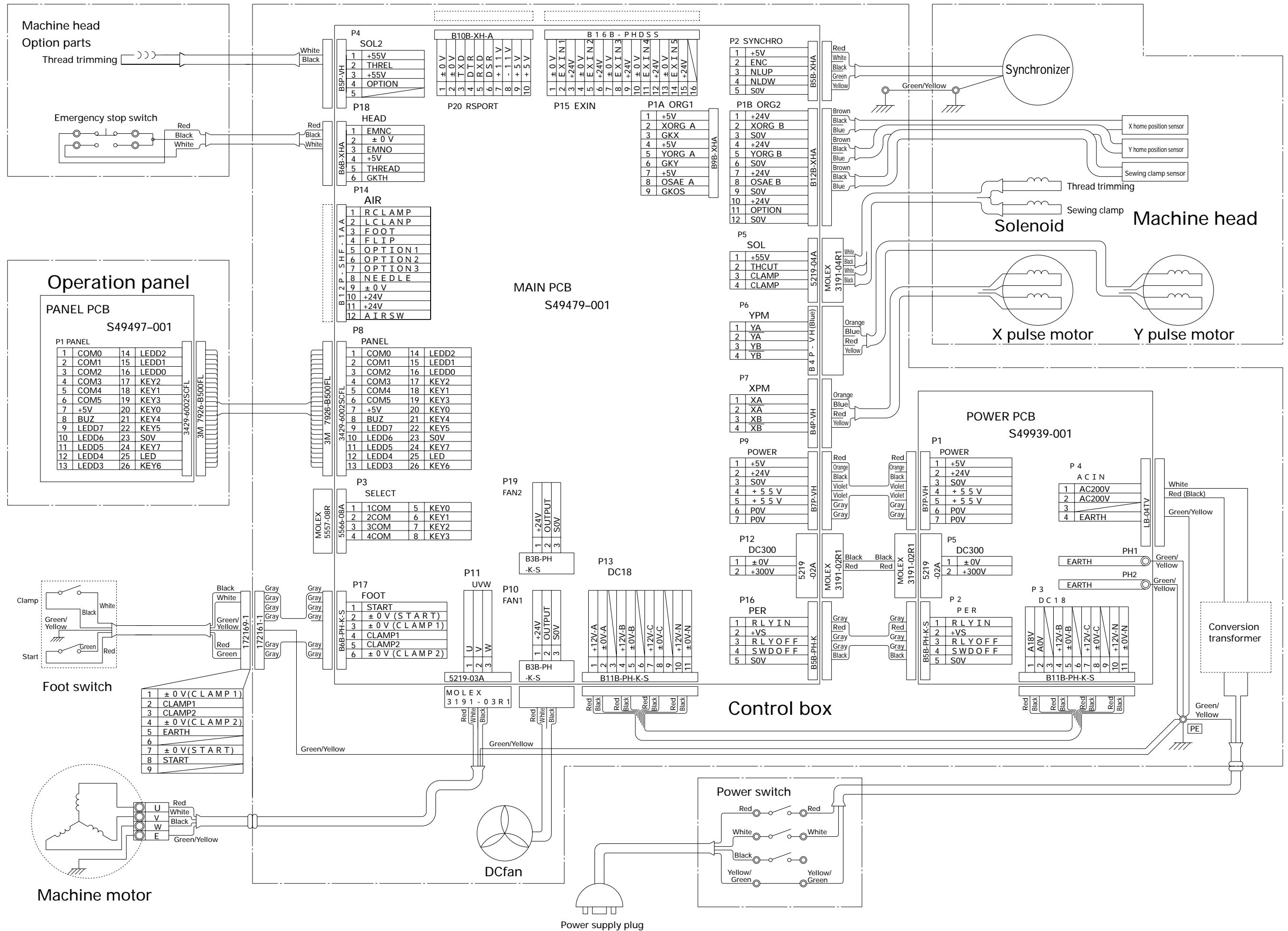

brother[®]

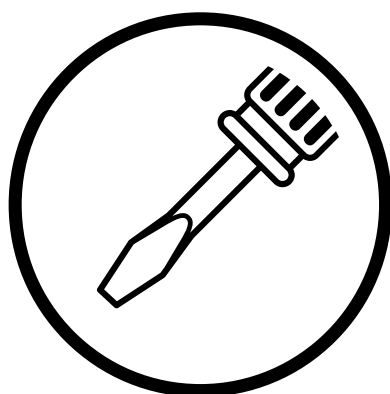

SERVICE MANUAL

BROTHER INDUSTRIES,LTD. NAGOYA,JAPAN

Printed in Japan

118-V30
I9100769B
1999.11. (1)