

BAS-6200

BAS-6220

Automatic Lockstitch Pocket Welt Sewer
Automatic Lockstitch Slant Pocket Welt Sewer

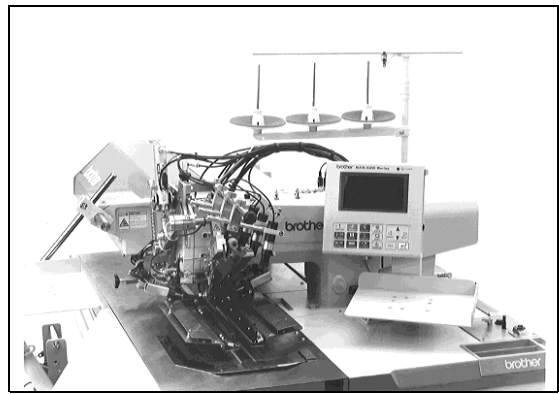

Specifications

Model	BAS-6200	BAS-6220
Head	Machine with double needles and center knife	Machine with double needles and center knife
Sewing speed	Maximum: 3,000 rpm	
Welting	Parallel double welting, parallel single welting (with flap, without flap)	Parallel double welting, parallel single welting, slant double welting, slant single welting, and trapezoid stitch (with flap, without flap)
Needle gauge	8, 10, 12, 14, 16, 18, 20 mm Standard: 12 mm	
Maximum seam length	220 mm (Standard)	
Minimum seam length	When corner knife is not used : 15 mm When corner knife is used : 29 mm (for 12 mm needle gauge)	
Backtack stitch length	1 mm (Standard) (Condense 0.4 – 2.0 mm, Backtack 0.8 – 3.4 mm)	
Backtack seam length	4mm (Standard) 0 – 6 mm, Needle swinging 0 – 5 mm	
No. of program	20 (comment entry and copying possible)	
No. of cycle program	10 (8 programs per cycle, intermediate stacker operation possible)	
Feed speed	Max. 45 m / min	
Lower thread counter	3 types, 0 – 999 (Bobbin thread sensor is optional)	
Language support	0: English 1: German 2: Italian 3: French 4: Portuguese 5: Spanish 6: Turkey 7: Chinese (Unsimplied) 8: Japanese 9: Indonesian	
Needle to be used	Mtx 190#16 (#14 - #18)	
Hook	Horizontal double rotary hook	
Power supply	Single phase 220V, Three phase 200 V · 220 V · 380 V · 400 V · 415 V 600 VA	
Air consumption	60 l / min	
Weight	222.5 kg	
Machine dimensions	(L) 1,350 mm x (W) 1,010 mm x (H) 1,200 mm	
Machine time	5.6 sec. (Seam length: 190 mm Stitch length: 2.8 mm Sewing speed: 3,000 rpm Condense stitch)	

Standard equipment

- 3-color marking light
 - Upper thread breakage detector
 - Pocket bag presser
 - Air gun
- *Binder for single welting is not included in accessory kit.

Use

	BAS-6200	BAS-6220
Parallel pocket welting	○	○
Parallel flap attaching	○ (Optional)	○
Slant pocket welting	X	○
Slant flap attaching	X	○

Optional parts

Knife

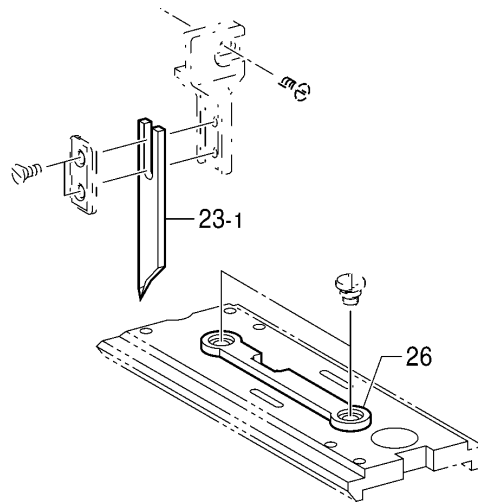

Ref. No.	Part name	Part code	Q'ty
23-1	Upper knife C	S59152-001	1
26	Fixed knife, ceramic	S36355-001	1
	Fixed knife	153020-001	1

Optional parts

Gauge parts

BAS-6200

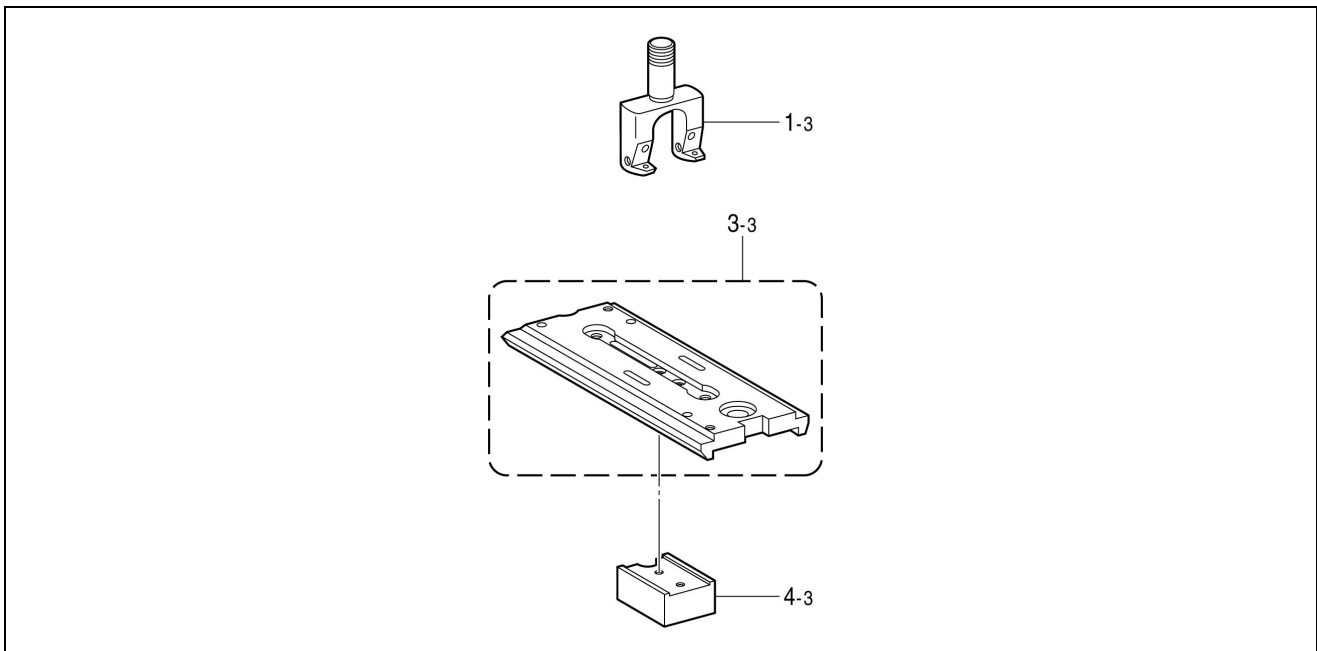

Ref. No.	Part name	Part code	Q'ty
1-3	Needle clamp assy	※	1
3-3	Needle plate assy	※	1
4-3	Loop guide	※	1

*The needle clamp assy, the needle plate assy, and the loop guide are different depending on needle gauge (8 mm, 10 mm, 12 mm, 14 mm, 18 mm, 20 mm). Please refer to the Gauge parts list that appears on and after page 25 and order proper ones.

Optional parts
Gauge parts
BAS-6220

" 補給用部品 / For supply parts "

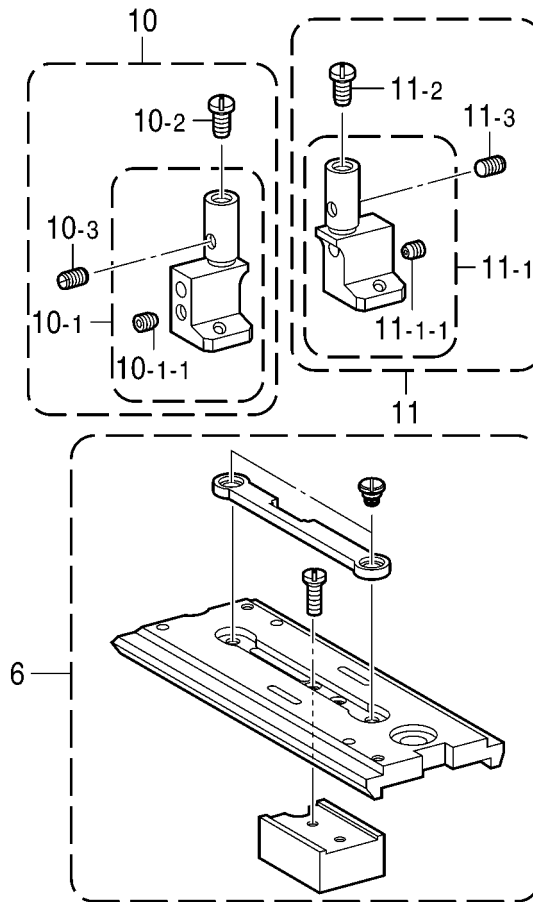

Ref. No.	Part name	Part code	Q'ty
6	Needle plate set, R	※	1
10	Needle clamp set, L	※	1
10-1	Needle clamp assy, L	※	1
10-1-1	Set screw, socket (CP) SM3.18	146427-001	1
10-2	Set screw, SM3.18	149831-101	1
10-3	Set screw, SM3.18	S13085-001	1
11	Needle clamp set, R	※	1
11-1	Needle clamp assy, R	※	1
11-1-1	Set screw, socket (CP) SM3.18	146427-001	1
11-2	Set screw, SM3.18	149831-101	1
11-3	Set screw, SM3.18	S13085-001	1

*The needle clamp assy, the needle plate assy, and the loop guide are different depending on needle gauge (8 mm, 10 mm, 12 mm, 14 mm, 18 mm, 20 mm). Please refer to the Gauge parts list that appears on and after page 25 and order proper ones.



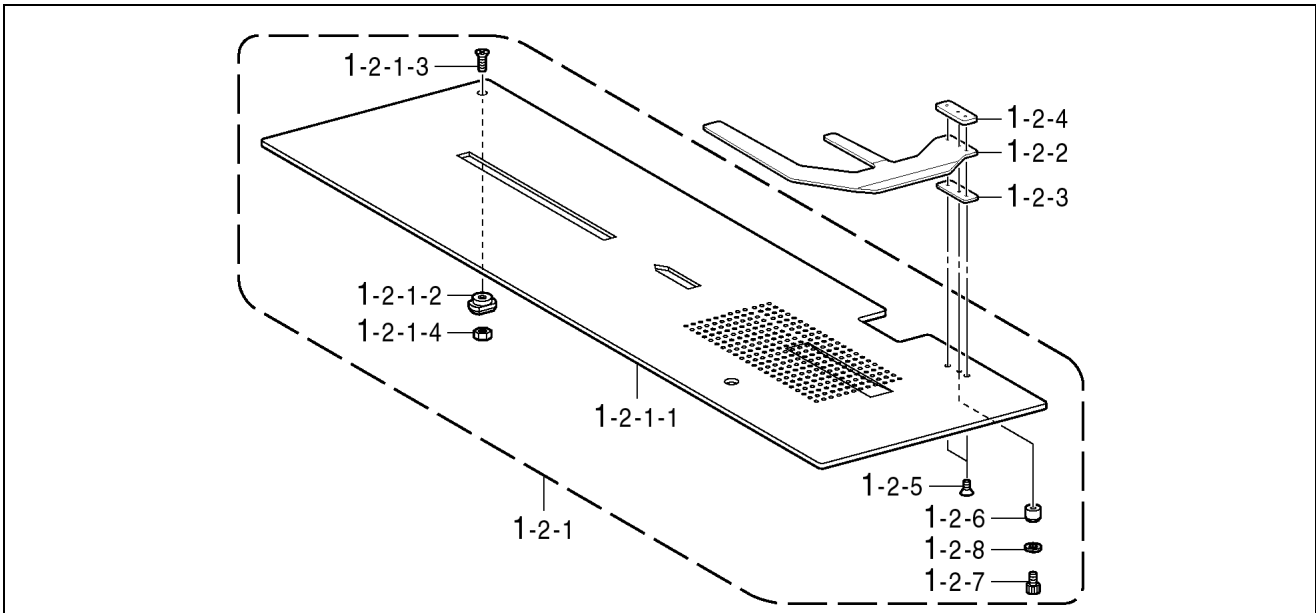

Optional parts
Gauge parts
BAS-6200 · 6220

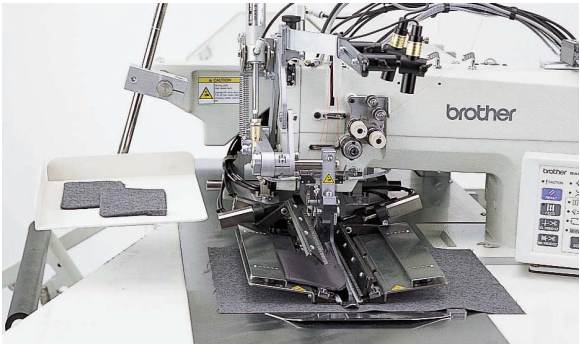

Ref. No.	Part name	Part code	Q'ty
1-2	Slide plate set, XX-YY	※	1
1-2-1	Slide plate assy, XX-YY	※	1
1-2-1-1	Slide plate	※	1
1-2-1-2	Pin	S53431-001	1
1-2-1-3	Screw, flat M4 × 14	004401-414	1
1-2-1-4	Nut, 2 M4	021400-206	1
1-2-2	Separator	S53432-000	1
1-2-3	Spacer, A	S53433-000	1
1-2-4	Spacer, B	S53434-000	1
1-2-5	Screw, flat M 3 × 5	004300-513	2
1-2-6	Collar	S53518-001	1
1-2-7	Bolt, socket M 3 × 8	018300-836	1
1-2-8	Washer, spring 2 - 3	028030-246	1

*The slide plate set, the slide plate assy, and the slide plate are different depending on needle gauge (8 mm, 10 mm, 12 mm, 14 mm, 18 mm, 20 mm). Please refer to the Gauge parts list that appears on and after page 25 and order proper ones.

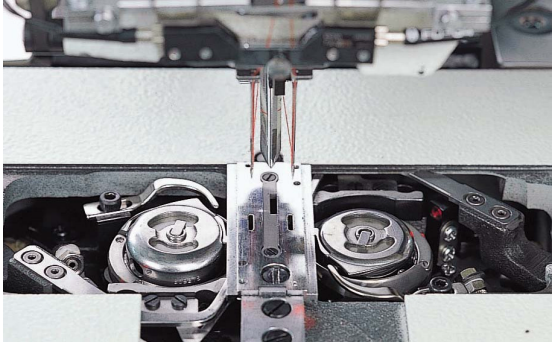
Optional device

<p>Flap presser</p>	 A Brother sewing machine with a flap presser attachment. The presser is a white plastic tray that holds fabric flaps flat while sewing. The machine is white and has the 'brother' logo on the side.
<p>Bar stacker</p>	 A Brother sewing machine with a bar stacker attachment. The stacker is a long, thin metal bar that extends from the front of the machine to help stack fabric pieces. The machine is white and has the 'brother' logo on the side.
<p>Bobbin thread sensor</p>	 A close-up view of the bobbin thread sensor mechanism. It shows two metal bobbins mounted on a central shaft, with a sensor arm positioned above them to detect thread levels. The mechanism is made of polished metal.
<p>Darts stretcher *1 *The air manifold, 5 with box which is sold separately is required.</p>	 A Brother sewing machine with a darts stretcher attachment. The stretcher is a metal frame that holds fabric taut while sewing darts. A person's hands are visible adjusting the fabric. The machine is white and has the 'brother' logo on the side.

*1: The air manifold, 5 with box which is sold separately is required.

Roller stacker
*1

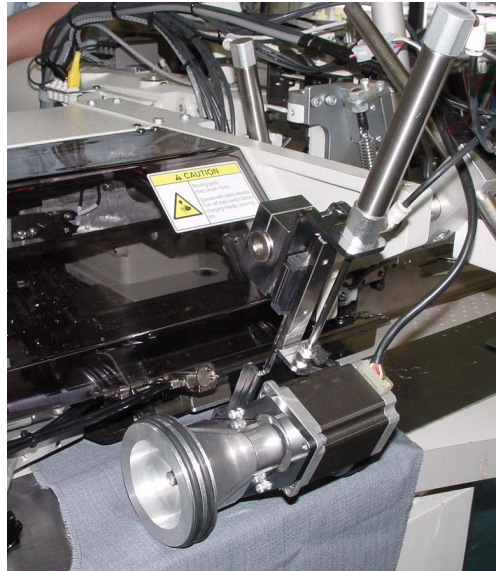

Waist presser
*1



Suction device
*1 *2

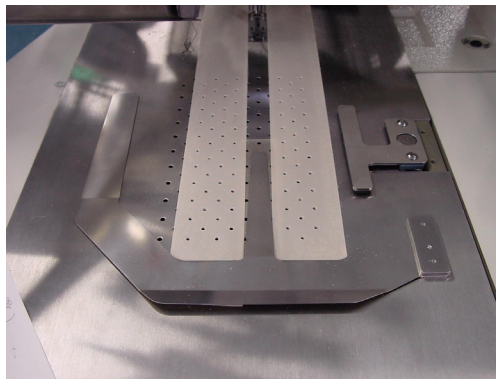

*1: The air manifold, 5 with box which is sold separately is required.
*2: Blow motor for suction device is optional.

Optional device
Bar stacker

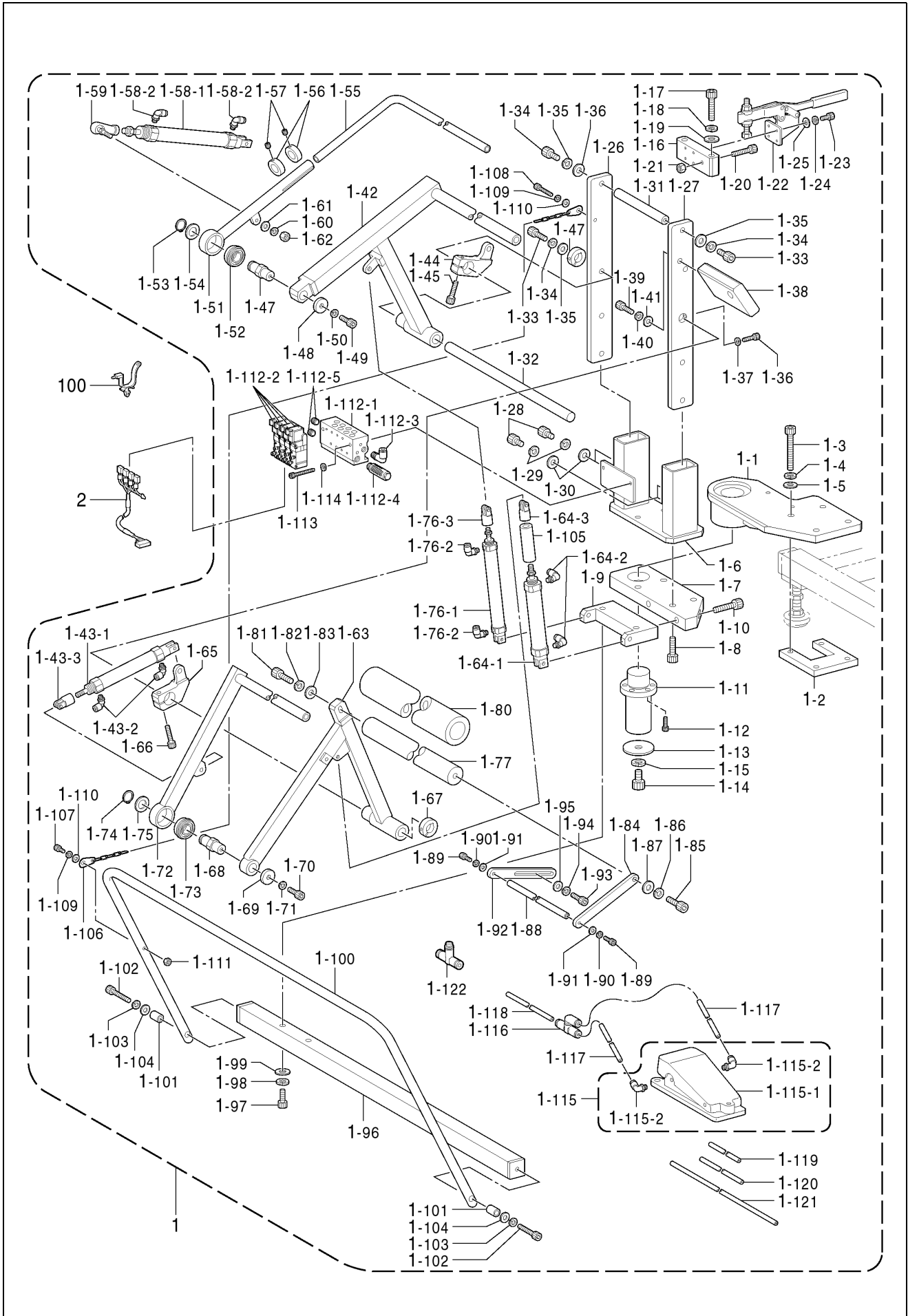

Optional device

Bar stacker

Ref. No.	Part name	Part code	Q'ty
1	Bar stacker assy	S54613-001	1
1-1	Base plate	S54114-001	1
1-2	Tap plate	S54115-001	1
1-3	Screw, socket M10 × 80	018108-036	4
1-4	Washer, spring 2 - 10	028100-246	4
1-5	Washer, plain M 10	025100-236	4
1-6	Bracket	S54111-001	1
1-7	Base	S54110-000	1
1-8	Bolt, socket M 10 × 30	018103-036	4
1-9	Cylinder block	S54116-001	1
1-10	Bolt, socket M 10 × 40	018104-036	2
1-11	Shaft	S54112-001	1
1-12	Bolt, socket M5 × 14	018501-436	6
1-13	End plate	S54113-001	1
1-14	Bolt, socket M 12 × 14	018121-436	1
1-15	Washer, spring 2 – 12	028120-246	1
1-16	Stopper block	S54109-001	1
1-17	Bolt, socket M 10 × 50	018105-036	2
1-18	Washer, spring 2 – 10	028100-246	2
1-19	Washer, plain M 10	025100-236	2
1-20	Bolt, M 8 × 50	S24089-001	1
1-21	Nut, 2 M8	021080-206	1
1-22	Toggle clamp	S54597-000	1
1-23	Bolt, socket M6 × 12	018061-236	4
1-24	Washer, spring 2 - 6	028060-246	4
1-25	Washer, plain M 6	025060-236	4
1-26	Fixing plate, L	S54123-001	1
1-27	Fixing plate, R	S54122-001	1
1-28	Screw, socket M 10 × 20	018102-036	4
1-29	Washer, spring 2 – 10	028100-246	4
1-30	Washer, plain M 10	025100-236	4
1-31	Shaft, L = 126	S54108-001	1
1-32	Fulcrum shaft	S54117-001	1
1-33	Bolt, socket M 8 × 20	018082-036	3
1-34	Washer, spring 2 - 8	028080-246	3
1-35	Washer, plain M 8	025080-236	3
1-36	Bolt, socket M 5 × 20	018502-036	1
1-37	Washer, spring 2 – 5	028050-246	1
1-38	Stopper block	S54125-001	1
1-39	Bolt, socket M 8 × 25	018082-536	2
1-40	Washer, spring 2 – 8	028080-246	2
1-41	Washer, plain M 8	025080-236	2
1-42	Clamp link	S54140-001	1
1-43	Cylinder assy	S54137-000	1
1-43-1	Air cylinder, 20 × 100	S54136-000	1
1-43-2	Elbow, KQWL0601S	S53981-000	2
1-43-3	Knuckle joint	S54135-000	1
1-44	Cylinder holder	S54118-001	1
1-45	Bolt, socket M 6 × 30	018063-036	1
1-46	Set screw collar	S54596-000	1
1-47	Shaft	S54126-001	1
1-48	End plate	S54127-001	1
1-49	Bolt, socket M8 × 16	018081-636	1
1-50	Washer, spring 2 – 8	028080-246	1
1-51	Wiper link	S54120-001	1
1-52	Ball bearing, 6004DDUNR	S54595-000	2
1-53	Retaining ring, external C20	048200-142	1
1-54	Spacer	S46191-001	1

Optional device
Bar stacker

Ref. No.	Part name	Part code	Q'ty
1-55	Pipe	S54119-001	1
1-56	Holder	S54106-001	2
1-57	Set screw, socket (FT) M6 × 6	012060-636	2
1-58	Cylinder asy	S54591-000	1
1-58-1	Air cylinder, 20 × 150	S54592-000	1
1-58-2	Elbow, KQWL0601S	S53981-000	2
1-59	Rod end	S54594-000	1
1-60	Washer, spring 2-8	028080-246	1
1-61	Washer, plain M8	025080-236	1
1-62	Nut, 2 M8	021080-206	1
1-63	Link, F-roller	S54121-001	1
1-64	Cylinder assy	S54138-000	1
1-64-1	Air cylinder, 32 × 125	S54139-000	1
1-64-2	Elbow, KQWL0601S	S53981-000	2
1-64-3	Knuckle joint	S54598-000	1
1-65	Cylinder holder	S54118-001	1
1-66	Bolt, socket M6 × 30	018063-036	1
1-67	Set screw collar	S54596-000	1
1-68	Shaft	S54126-001	1
1-69	End plate	S54127-001	1
1-70	Bolt, socket M8 × 16	018081-636	1
1-71	Washer, spring 2-8	028080-246	1
1-72	Clamper link	S54124-001	1
1-73	Ball bearing, 6004DDUNR	S54595-000	2
1-74	Retaining ring, external C20	048200-142	1
1-75	Spacer	S46191-001	1
1-76	Cylinder assy	S54591-000	1
1-76-1	Air cylinder, 20 × 150	S54592-000	1
1-76-2	Elbow, KQWL0601S	S53981-000	2
1-76-3	Knuckle joint	S54135-000	1
1-77	Table	S54134-000	1
1-80	Rubber plate	S54606-000	1
1-81	Bolt , socket M10 × 35	018103-536	1
1-82	Washer, spring 2-10	028100-246	1
1-83	Washer, plain M10	025100-236	1
1-84	Connecting link, A	S54129-001	1
1-85	Bolt, socket M10 × 20	018102-036	1
1-86	Washer, spring 2-10	028100-246	1
1-87	Washer, plain M10	025100-236	1
1-88	AUX. Shaft	S54128-001	1
1-89	Bolt, socket M6 × 12	018061-236	2
1-90	Washer, spring 2-6	028060-246	2
1-91	Washer, plain M6	025060-236	2
1-92	Connecting link, B	S54130-001	1
1-93	Bolt, socket M8 × 20	018082-036	1
1-94	Washer, spring 2-8	028080-246	1
1-95	Washer, plain M8	025080-236	1
1-96	Guard base	S54105-001	1
1-97	Bolt socket M 10 × 12	018101-236	2
1-98	Washer, spring 2-10	028100-246	2
1-99	Washer, plain M10	025100-236	2
1-100	Guard	S54132-001	1
1-101	Pipe collar	S54133-001	2
1-102	Bolt, socket M8 × 30	018083-036	2
1-103	Washer, spring 2-8	028080-246	2
1-104	Washer, plain M8	025080-236	2
1-105	Stopper collar	S54107-000	1
1-106	Chain	S54605-000	1

Optional device**Bar stacker**

Ref. No.	Part name	Part code	Q'ty
1-107	Bolt, socket M6 × 12	018061-236	1
1-108	Bolt, socket M6 × 30	018063-036	1
1-109	Washer, spring 2-8	028080-246	2
1-110	Washer, plain M8	025080-236	2
1-111	Nut, 2 M6	021060-206	1
1-112	Valve unit, 4	S54593-000	1
1-112-1	Manifold, 4	S54607-000	1
1-112-2	Valve, VQZ2151S-5	S39116-100	4
1-112-3	Elbow, KQ2L0801S	S54600-000	1
1-112-4	Silencer	140682-001	1
1-112-5	Cap, 1/8	153274-001	2
1-113	Bolt, socket M5 × 30	018503-036	2
1-114	Washer, spring 2-5	028050-246	2
1-115	Pedal assy	S54612-000	1
1-115-1	Pedal	S54610-000	1
1-115-2	Elbow, KQ2L0602S	S54611-000	2
1-116	Check valve, 06; 3-port	S54609-000	1
1-117	Air tube, 0604U027B	S54601-000	2
1-118	Air tube, 0604U035B	S54602-000	1
1-119	Air tube, 0604U026B	S54603-000	3
1-120	Air tube, 0604U032B	S54604-000	2
1-121	Air tube, 0604U184B	S54599-000	1
1-122	Speed controller	S55874-000	1
2	Stacker harness	S52471-000	1
100	Cord clamp, 19P7	S39821-000	1

Optional device
Flap presser

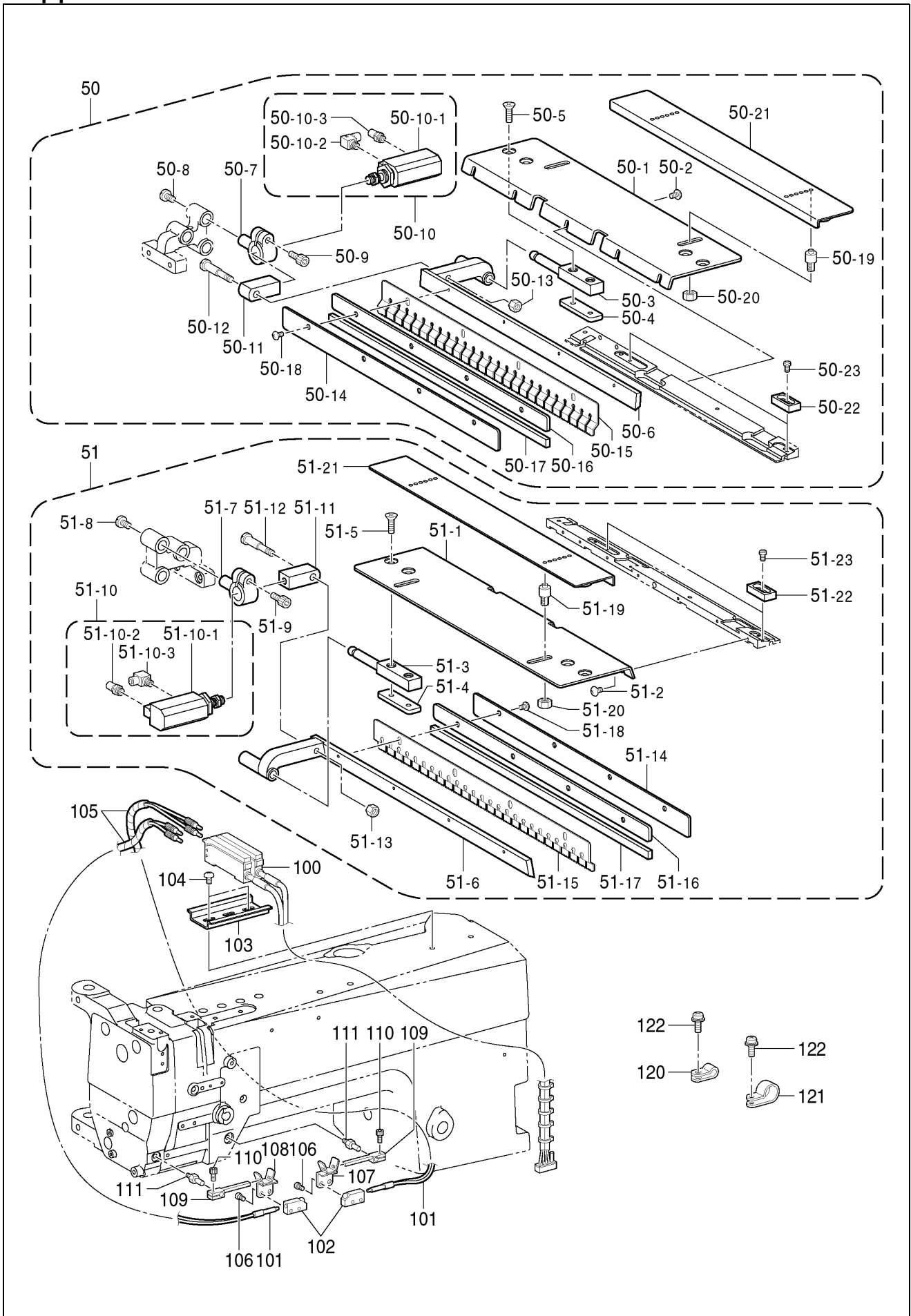

Optional device

Flap presser

Ref. No.	Part name	Part code	Q'ty
	<For pocket flap>		
	Flap clamp device, assy	S59548-001	1
50	Flat clamp assy, R	S53565-000	1
50-1	Auxiliary plate	S53566-000	1
50-2	Screw, truss M4 × 6	008400-604	5
50-3	Fulcrum shaft	S53567-001	1
50-4	Nut plate, M5	S53568-001	1
50-5	Screw, flat M5 × 16	004501606	2
50-6	Flap clamp, R	S53569-001	1
50-7	Cylinder base	S53540-001	1
50-8	Screw, SM4.37	115503-001	1
50-9	Bolt, socket M 5 × 10	018501-036	1
50-10	Cylinder assy	S53541-000	1
50-10-1	Cylinder, 16 × 20	S14666-000	1
50-10-2	Tube elbow, M-5HL-4	S12150-000	1
50-10-3	Joint, w/screw M5	S53542-000	1
50-11	Joint	S53571-001	1
50-12	Shoulder screw, M5	S53572-001	1
50-13	Nut, 2 M5	021500-216	1
50-14	Flap clamp blade, A	S53573-001	1
50-15	Flap clamp blade, B	S53574-000	1
50-16	Flap clamp blade, C	S53575-001	1
50-17	Sponge, 258 × 8 × 3	S53989-000	1
50-18	Screw, truss M3 × 6	008300-604	4
50-19	Stud, 8 w/screw M5	S53576-001	2
50-20	Nut, 2 M5	021500-216	2
50-21	Flap gauge assy	S53577-000	1
50-22	Flap stopper	S53580-001	2
50-23	Screw, pan M3 × 6	002300603	2
51	Flap clamp assy, L	S53581-000	1
51-1	Auxiliary plate	S53566-001	1
51-2	Screw, truss M4 × 6	008400-604	5
51-3	Fulcrum shaft	S53567-001	1
51-4	Nut plate, M5	S53568-001	1
51-5	Screw, flat M5 × 16	004501-606	2
51-6	Flap clamp, L	S53582-001	1
51-7	Cylinder base	S53540-001	1
51-8	Screw, SM4.37	115503-001	1
51-9	Bolt, socket M5 × 10	018501-036	1
51-10	Cylinder assy	S53541-000	1
51-10-1	Cylinder, 16 × 20	S14666-000	1
51-10-2	Tube elbow, M-5HL-4	S12150-000	1
51-10-3	Joint, w/screw M5	S53542-000	1
51-11	Joint	S53571-001	1
51-12	Shoulder screw, M5	S53572-001	1
51-13	Nut, 2 M5	021500-216	1
51-14	Flap clamp blade, A	S53573-001	1
51-15	Flap clamp blade, B	S53574-000	1
51-16	Flap clamp blade, C	S53575-001	1
51-17	Sponge, 258 × 8 × 3	S53989-000	1
51-18	Screw, truss M3 × 6	008300-604	4
51-19	Stud, 8 w/screw M5	S53576-001	2
51-20	Nut, 2 M5	021500-216	2
51-21	Flap gauge assy	S53577-000	1
51-22	Flap stopper	S53580-001	2
51-23	Screw, pan M3 × 6	002300-603	2
100	Flap sensor	S52454-000	1
101	Fiber, FD-G4	S52961-000	2

Optional device
Flap presser

Ref. No.	Part name	Part code	Q'ty
102	Side lens	S52962-000	2
103	DIN rail, 75	S52965-001	1
104	Screw, truss M4 × 6	008400-604	2
105	Spiral, 720SS	S53588-000	2
106	Screw, pan M3 × 6	002300-603	4
107	Sensor holder, R	S53583-000	1
108	Sensor holder, L	S53584-000	1
109	Sensor guide	S53585-001	2
110	Bolt, socket M3 × 6	018300-636	2
111	Sensor stud, M5	S53586-001	2
120	Cord holder, ;NK-3N	S10243-000	1
121	Cord holder, 7N	149287-000	1
122	Screw, pan (S/P washer) M4 × 8	0A5400-805	2

Optional device
Bobbin thread sensor

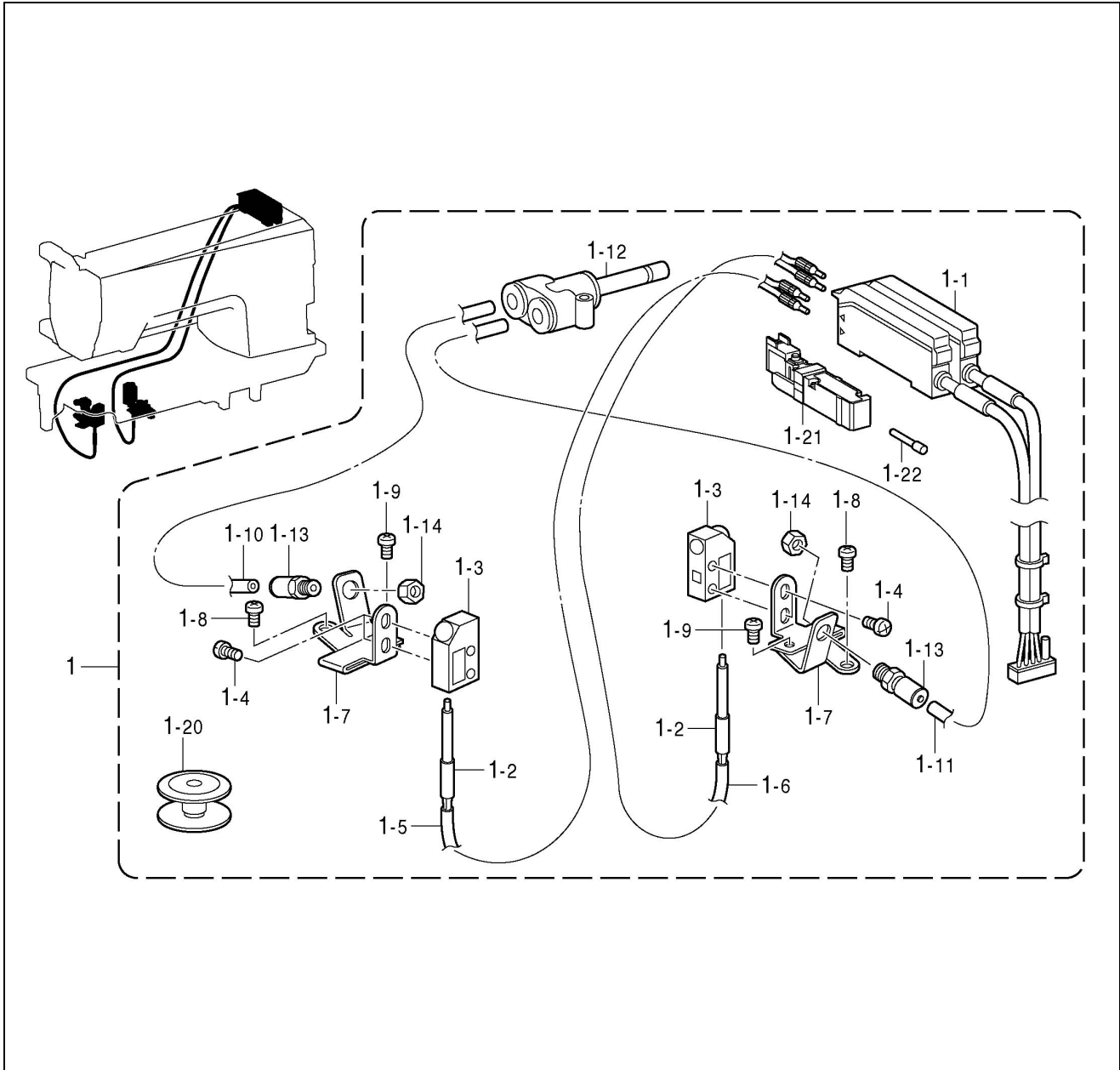

Ref. No.	Part name	Part code	Q'ty
1	Sensor assy, L / thread	S59371-001	1
1-1	Detector sensor, L-thread	S52469-000	1
1-2	Fiber, FD-G4	S52961-000	2
1-3	Side lens	S52962-000	2
1-4	Screw, pan M3 × 6	062300-606	4
1-5	Tube, L=950	S53421-000	1
1-6	Tube, L=700	S53423-000	1
1-7	Sensor holder	S53422-000	2
1-8	Screw, pan M3 × 6	062300-606	2
1-9	Screw, pan M3 × 6	062300-606	2
1-10	Air tube, 0604U0085B	S53617-000	1
1-11	Air tube, 0604U0080B	S53618-000	1
1-12	Branch, Y	S53978-000	1
1-13	Hose nipple, 4M5	S11433-000	2
1-14	Nut, 3 M5	021500-316	2
1-20	Bobbin	S52490-001	2
1-21	Valve, VQZ2151-5	S39115-100	1
1-22	Plug, 4	S53983-000	1

Optional device
Darts stretcher

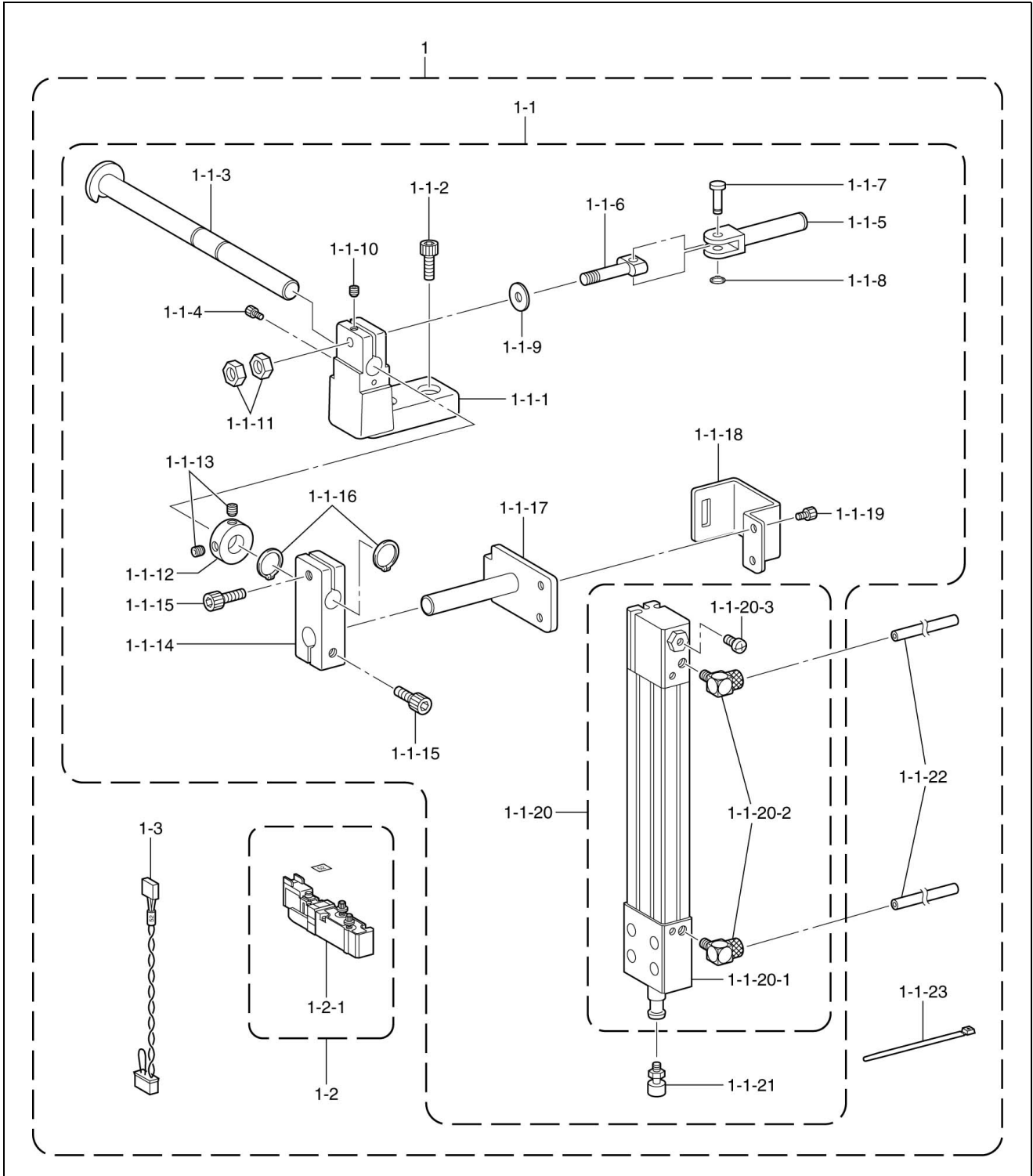

Optional device
Darts stretcher

Ref. No.	Part name	Part code	Q'ty
1	Dart stretcher, w/box	S57598-001	1
1-1	Darts stretcher	S57602-001	1
1-1-1	Setting block	S56211-001	1
1-1-2	Bolt, socket M5 × 16	018501-636	2
1-1-3	Support bar	S56212-001	1
1-1-4	Bolt, socket M3 × 6	018300-636	1
1-1-5	Cam lever	S53788-001	1
1-1-6	Rod	S56215-001	1
1-1-7	Pin, 002	S53544-001	1
1-1-8	Retaining ring, E2.5	048025-342	1
1-1-9	Washer	S39690-021	1
1-1-10	Set screw, socket (FT) M5 × 5	012500-536	1
1-1-11	Nut, 3 M4	021400-316	2
1-1-12	Set screw collar	S30012-001	1
1-1-13	Set screw, socket (FT) M6 × 6	012060-636	2
1-1-14	Block	S56216-001	1
1-1-15	Bolt, socket M6 × 14	018061-436	2
1-1-16	Retaining ring, external C12	048120-142	2
1-1-17	Cylinder setting bar	S56217-001	1
1-1-18	Setting plate	S56219-001	1
1-1-19	Bolt, socket M3 × 6	018300-636	2
1-1-20	Cylinder assy	S56221-000	1
1-1-20-1	Cylinder	S56222-000	1
1-1-20-2	Tube elbow, M-5HL-4	S12150-000	2
1-1-20-3	Screw, pan M2 × 12	002021-205	1
1-1-21	Stopper bolt	S56220-000	1
1-1-22	Air tube, 0425S110B	S56213-000	2
1-1-23	Band, PLT1M	S04557-000	1
1-2	Valve mark 52	S57600-000	1
1-2-1	Valve, VQZ2151S-5	S39116-100	1
1-3	Valve harness	S52981-000	1

*To use the darts stretcher, the air manifold, 5 with box (S57604-001), which is sold separately, is required. If you already have the air manifold 5 with box, you do not need to purchase a new one. (The complete air manifold 5 with box can be connected to other devices besides the darts stretcher.)

Optional device
Roller stacker

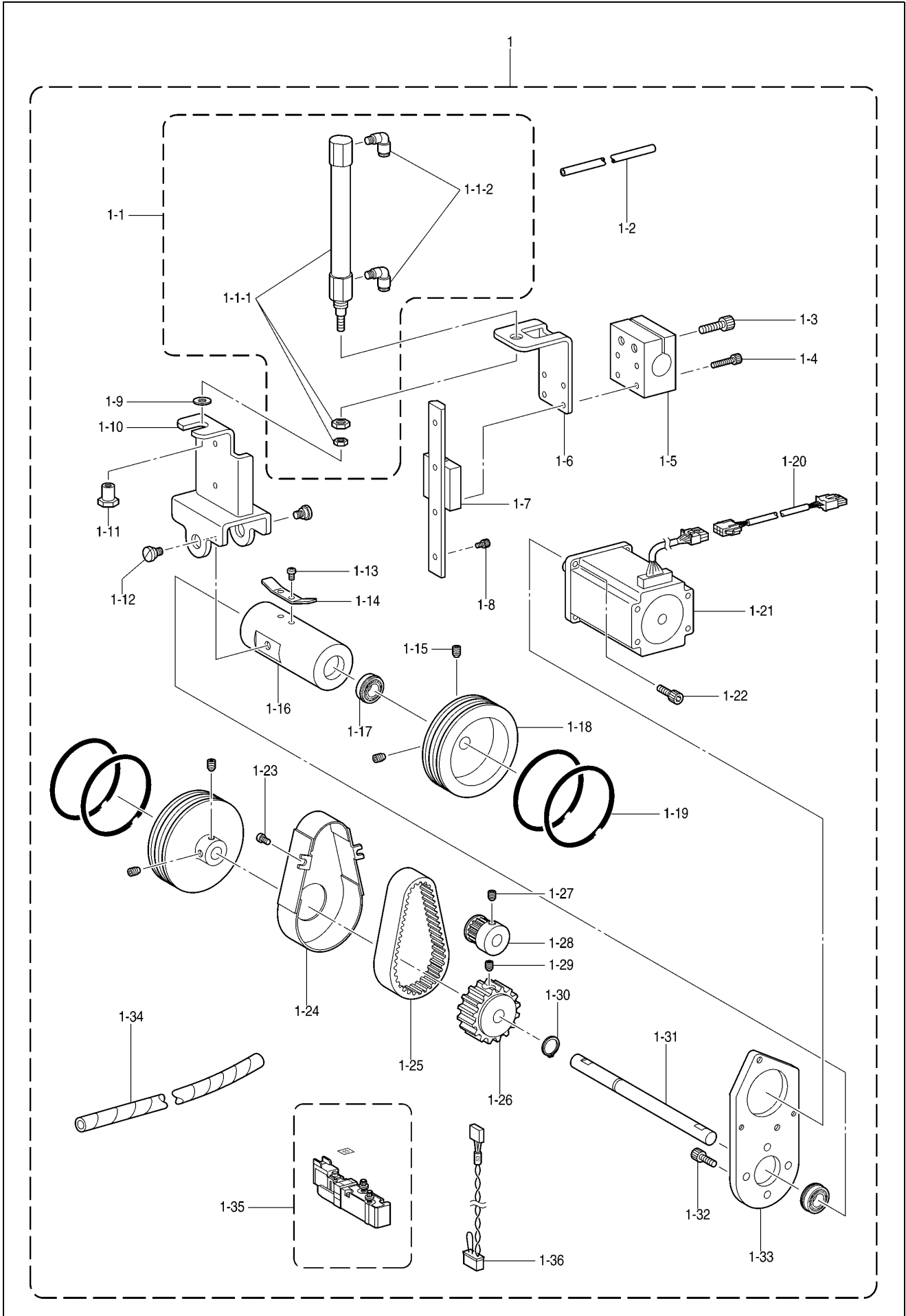

Optional device

Roller stacker

Ref. No.	Part name	Part code	Q'ty
1	Roller stacker assy, w/box	SA0170-001	1
1-1	Cylinder assy	SA0166-000	1
1-1-1	Cylinder, CJ2B16	SA0167-000	1
1-1-2	Joint	S53488-000	1
1-2	Air tube, 4 L=1370	S41941-000	2
1-3	Bolt, socket M6X10	018061-036	2
1-4	Bolt, socket M3X10	018301-036	4
1-5	Set block	SA0152-001	1
1-6	Angle	SA0154-001	1
1-7	Linear guide	SA0168-000	1
1-8	Bolt, socket M3X10	018301-036	2
1-9	Washer, plain M 5	025050-236	1
1-10	Roller frame	SA0153-001	1
1-11	Rod end	SA0160-001	1
1-12	Shoulder screw, SM5.95	159394-001	2
1-13	Screw, 4X8	062400-805	2
1-14	Spring, plate	SA0151-001	1
1-15	Set screw, socket (FT) M5X5	012500-536	4
1-16	Bearing holder	SA0156-000	1
1-17	Ball bearing , 6900N	076900-859	2
1-18	Roller	SA0158-000	2
1-19	O ring, P75	SA0165-000	4
1-20	Roller PM power harness	S52988-000	1
1-21	Pulse motor assy	S52987-000	1
1-22	Bolt, socket M4X10	018401-036	1
1-23	Bolt, socket M3X6	018300-636	2
1-24	Belt cover	SA0157-001	1
1-25	Timing belt	SA0161-000	1
1-26	Timing pulley, 32	SA0162-001	1
1-27	Set screw, socket (FT) M5X5	012500-536	1
1-28	Timing pulley, 12	SA0163-001	1
1-29	Set screw, socket (FT) M5X5	012500-536	1
1-30	Retaining ring, external C10	048100-143	1
1-31	Roller shaft	SA0159-001	1
1-32	Bolt, socket M4X10	018401-036	4
1-33	Motor side plate	SA0155-001	1
1-34	Spiral, 290S	S12212-000	1
1-35	Valve mark 53, assy	SA0169-000	1
1-36	Roller valve harness	S52984-000	1

*To use the roller stacker, the air manifold, 5 with box (S57604-001), which is sold separately, is required. If you already have the air manifold 5 with box, you do not need to purchase a new one. (The complete air manifold 5 with box can be connected to other devices besides the roller stacker.)

*The version "C" of PROM (MN, SE, MT) of the main PCB and PROM (PL) of the panel PCB or subsequent ones is required for this device.

**Optional device
Waist presser**

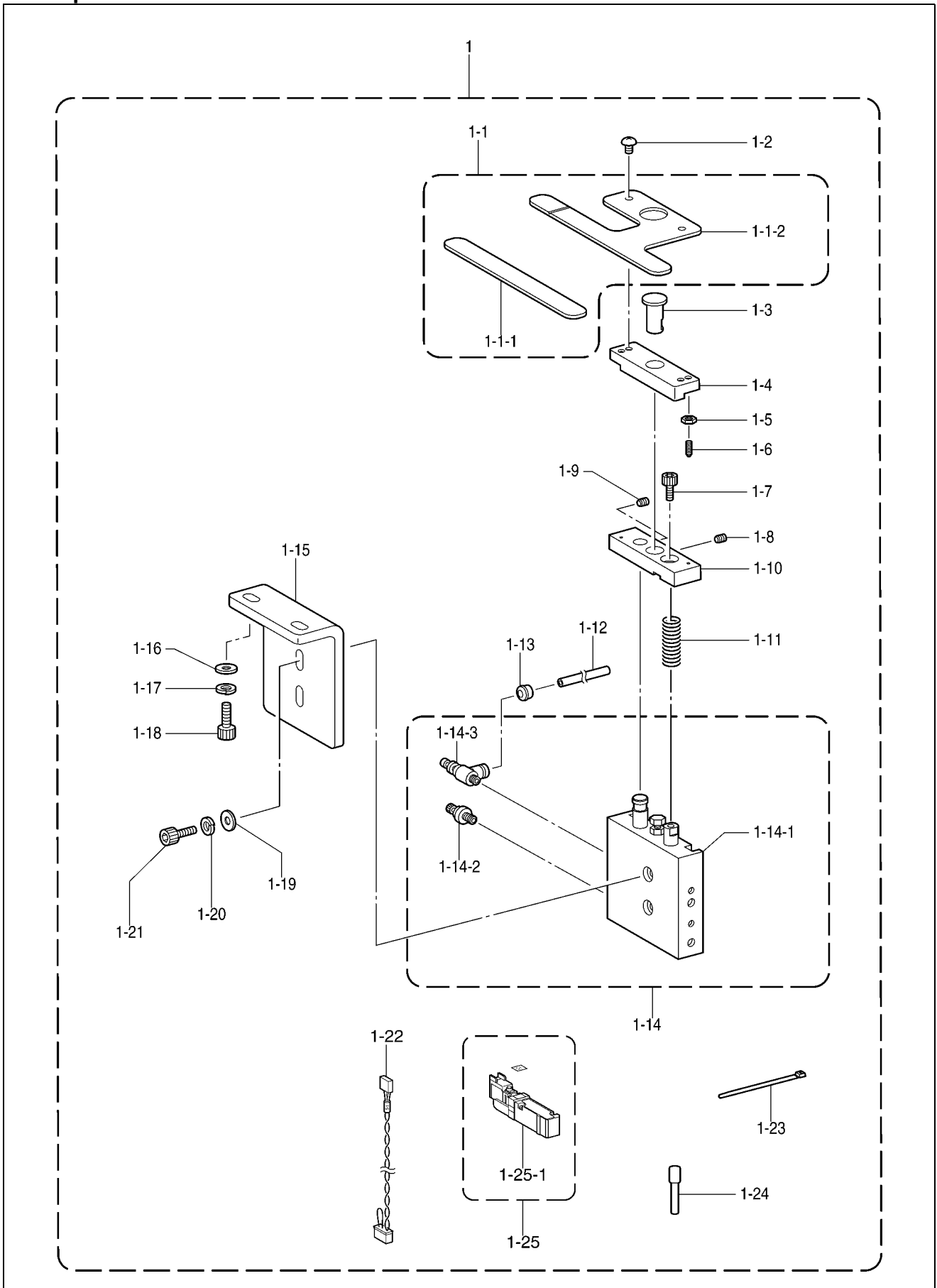

Optional device**Waist presser**

Ref. No.	Part name	Part code	Q'ty
1	Waist presser assy, w/box	S59551-001	1
1-1	Cloth presser assy	SA0043-000	1
1-1-1	Cloth presser rubber	S59396-000	1
1-1-2	Cloth presser	S59250-000	1
1-2	Screw, truss M4X6	008400-604	2
1-3	Pin, ;R-link	S51546-001	1
1-4	Rotary block	S59244-001	1
1-5	Nut, 2 M4	021400-206	2
1-6	Ball plunger	S59247-000	2
1-7	Bolt, socket M5X10	018501-022	1
1-8	Set screw, socket (FT) M6X6	012060-636	1
1-9	Set screw, socket (FT) M6X6	012060-636	1
1-10	Cylinder block	S59251-001	1
1-11	Spring, A; compression	141485-001	1
1-12	Air tube, L=900	S48480-003	1
1-13	Oil cap	112758-001	1
1-13-1	Cylinder assy	S59245-000	1
1-13-2	Cylinder 15X15	S59246-000	1
1-13-3	Exhaust throttle valve	S59248-000	1
1-14	Speed controller, AS1211M504	SA0788-000	1
1-15	Cylinder support	S59249-001	1
1-16	Washer, plain M 6	025060-236	2
1-17	Washer, spring 2-6	028060-246	2
1-18	Bolt, socket M6X16	018061-622	2
1-19	Washer, plain M 5	025050-236	2
1-20	Washer, spring 2-5	028050-246	2
1-21	Bolt, socket M5X14	018501-422	2
1-22	Waist valve harness	S52982-000	1
1-23	Band, PLT1M	S04557-000	1
1-24	Plug, 4	S53983-000	1
1-25-1	Valve mark 51	S59369-000	1
1-25-2	Valve, VQZ2151-5	S39115-100	1

*To use the waist presser, the air manifold, 5 with box (S57604-001), which is sold separately is required. If you already have the air manifold 5 with box, you do not need to purchase a new one. (The complete air manifold 5 with box can be connected to other devices besides the waist presser.)

Optional device
Suction device

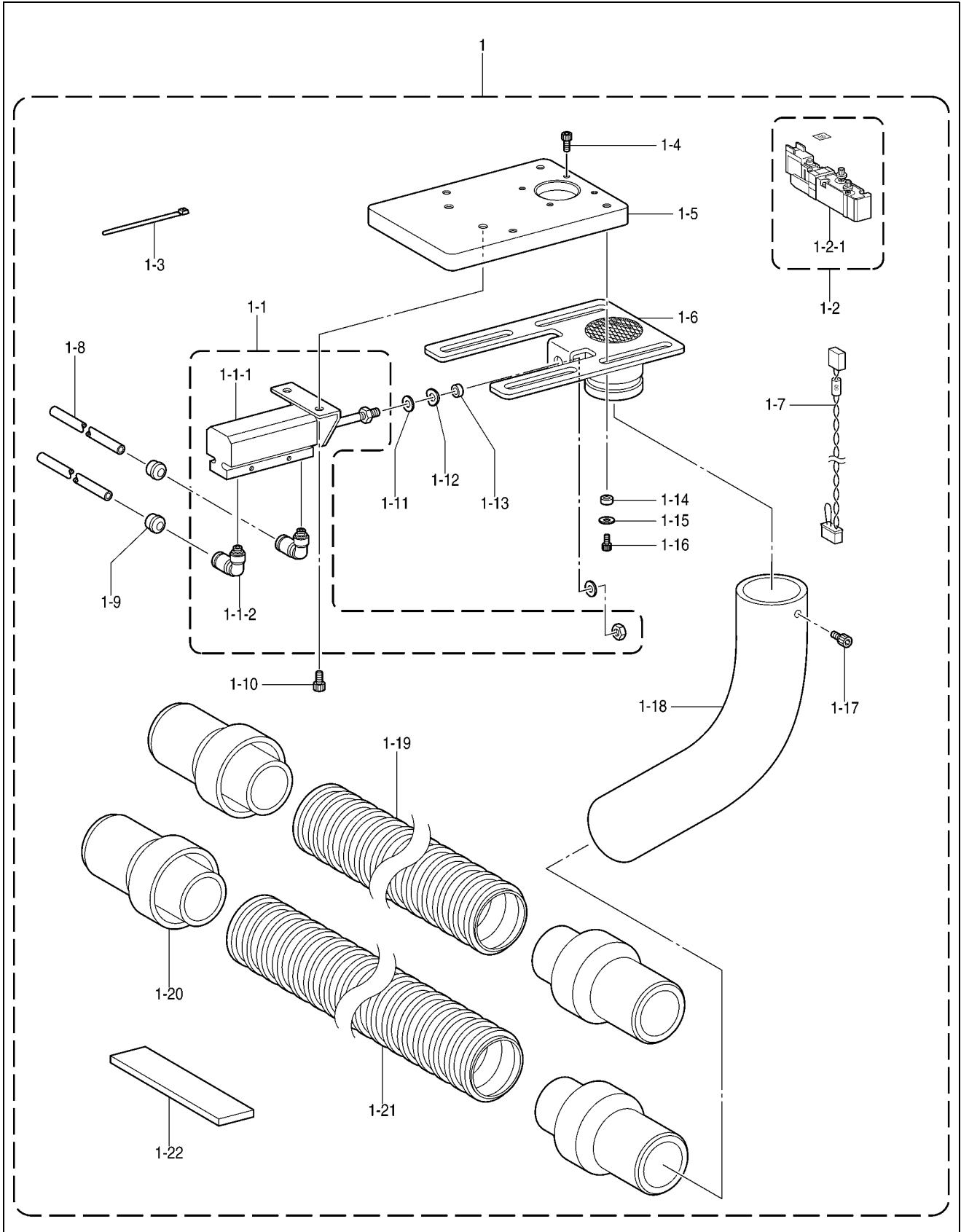

Optional device

Suction device

Ref. No.	Part name	Part code	Q'ty
1	Suction device assy, w/box	S59020-001	1
1-1	Cylinder 15X30 assy	S59011-000	1
1-1-1	Cylinder 15X30	S59012-000	1
1-1-2	Elbow, KQ2L06M5	S53734-000	2
1-2	Valve mark 50 assy	S59019-000	1
1-2-1	Valve, VQZ2151S-5	S39116-100	1
1-3	Band, PLT1M	S04557-000	1
1-4	Bolt, socket M4X12	018401-236	1
1-5	Setting plate	S59007-001	1
1-6	Slide plate assy	S59008-001	1
1-7	Vacuum valve harness	S52983-000	1
1-8	Air tube, L=900	S48480-003	2
1-9	Oil cap	112758-001	2
1-10	Bolt, socket M5X8	018500-836	2
1-11	Washer, plain M 5	025050-236	2
1-12	Washer, wave spring 6.45	107017-002	1
1-13	Lower thread retainer collar	153218-001	1
1-14	Collar	S50400-001	4
1-15	Washer	S19543-001	4
1-16	Bolt, socket M3X10	018301-036	4
1-17	Bolt, socket M5X8	018500-836	1
1-18	Pipe	S59373-001	1
1-19	Duct hose, S	S52998-000	1
1-20	Cuffs	S52999-000	4
1-21	Duct hose, L	S52997-000	1
1-22	Rubber sheet	S59262-000	1

*To use the suction device, the air manifold, 5 with box (S57604-001), which is sold separately, is required. If you already have the air manifold 5 with box, you do not need to purchase a new one. (The complete air manifold 5 with box can be connected to other devices besides the suction device.)

*The blower motor is sold separately.

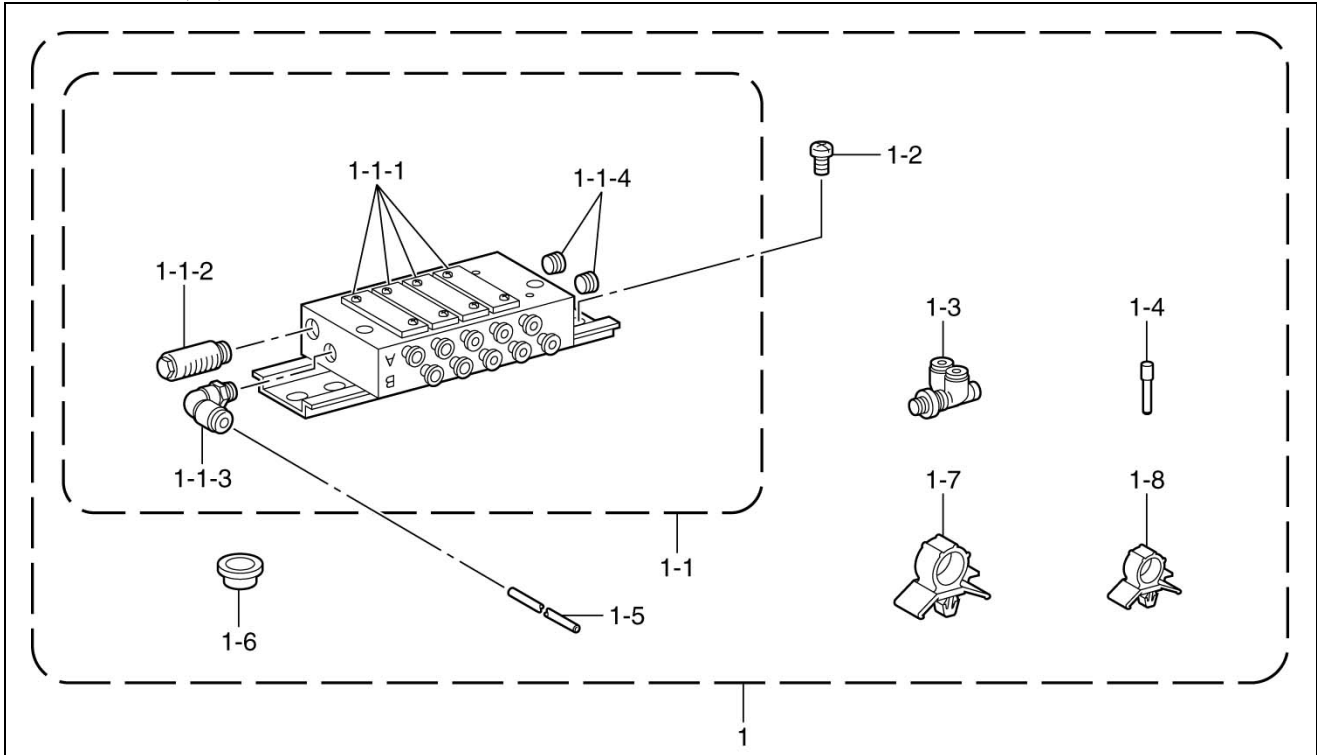

For 380 V / 400 V / 415 V	S59654-001 (Blower motor, 400V ;w/box)
For 200 V / 220 V	S59656-001 (Blower motor, 200V ;w/box)

Optional part
Air manifold, 5; w / box





Ref. No.	Part name	Part code	Q'ty
1	Air manifold, 5 :w/box	S57604-101	1
1-1	Manifold assy, 5	S56214-000	1
1-1-1	Blanking plate assy	S53982-000	4
1-1-2	Silencer	140682-001	1
1-1-3	Elbow, KQWL0601S	S53981-000	1
1-1-4	Cap, 1/8	153274-001	2
1-2	Screw, truss M4 x 6	008400-604	2
1-3	Branch elbow module	S57931-000	1
1-4	Plug, 6	S53984-000	1
1-5	Air tube, 0604S060B	S57615-000	1
1-6	Bushing, TB-1520	S52972-000	1
1-7	Cord clamp, 16-L	S09141-000	1
1-8	Cord clamp, 10-L	150349-001	2



Gauge parts list (BAS-6200)

		Needle gauge:8 mm	Needle gauge:10 mm	Needle gauge:12 mm	Needle gauge:14 mm	Needle gauge:16 mm	
Needle clamp assy		S59139-001 Needle clamp assy, 8 mm	S59140-001 Needle clamp assy, 10 mm	S59141-001 Needle clamp assy, 12 mm	S59142-001 Needle clamp assy, 14 mm	S59143-001 Needle clamp assy, 16 mm	
Needle plate set		S52571-001 Needle plate set, 8	S52572-001 Needle plate set, 10	S52573-001 Needle plate set, 12	S52574-001 Needle plate set, 14	S52575-001 Needle plate set, 16	
Needle plate assy		S52561-001 Needle plate assy, 8	S52562-001 Needle plate assy, 10	S52563-001 Needle plate assy, 12	S52564-001 Needle plate assy, 14	S52565-001 Needle plate assy, 16	
Loop guide		S52536-001 Loop guide, 8	S52537-001 Loop guide, 10	S52538-001 Loop guide, 12	S52539-001 Loop guide, 14	S52540-001 Loop guide, 16	
Slide plate set		S53428-000 Slide plate set, 8-12			S53435-000 Slide plate set, 14-16		
Slide plate assy		S53429-000 Slide plate assy, 8-12			S53436-000 Slide plate assy, 14-16		
Slide plate		S53430-001 Slide plate			S53430-002 Slide plate		
Binder	Double welting 	Medium- weight materials	S59271-000 Binder assy, 8W-13	S59275-000 Binder assy, 10W-17	S59279-000 Binder assy, 12W-21	S59283-000 Binder assy, 14W-25	S59287-000 Binder assy, 16W-29
		Light- weight materials	S59272-000 Binder assy, 8W-14	S59276-000 Binder assy, 10W-18	S59280-000 Binder assy, 12W-22	S59284-000 Binder assy, 14W-26	S59288-000 Binder assy, 16W-30
	Single welting 	Medium- weight materials	S59273-000 Binder assy, 8S-14	S59277-000 Binder assy, 10S-18	S59281-000 Binder assy, 12S-22	S59285-000 Binder assy, 14S-26	S59289-000 Binder assy, 16S-30
		Light- weight materials	S59274-000 Binder assy, 8S-15	S59278-000 Binder assy, 10S-19	S59282-000 Binder assy, 12S-23	S59286-000 Binder assy, 14S-27	S59290-000 Binder assy, 16S-31
Ceramic corner knife		S14050-001 Ceramic corner knife, S				S14051-001 Ceramic corner knife, L	
Knife base assy		S11521-001 Knife base assy, 8	S11522-001 Knife base assy, 10	S11523-001 Knife base assy, 12	S11524-001 Knife base assy, 14	S11525-001 Knife base assy, 16	
Fixed knife		S53521-001 Fixed knife, 8	S53494-001 Fixed knife, 10-12		S53495-001 Fixed knife, 14-16		
N/thread knife assy		S53522-001 N/Thread knife assy, 8	S53498-001 N/Thread knife assy, 10-12		S53501-001 N/Thread knife assy, 14-16		
Thread holding plate		S53523-001 Thread holding plate, 8	S53507-001 Thread holding plate, 10-12		S53508-001 Thread holding plate, 14-16		



Gauge parts list (BAS-6200)

		Needle gauge: 18 mm	Needle gauge: 20 mm	
Needle clamp assy		S59144-001 Needle clamp assy, 18 mm	S59145-001 Needle clamp assy, 20 mm	
Needle plate set		S52576-001 Needle plate set, 18	S52577-001 Needle plate set, 20	
Needle plate assy		S52566-001 Needle plate assy, 18	S52567-001 Needle plate assy, 20	
Loop guide		S52541-001 Loop guide, 18	S52542-001 Loop guide, 20	
Slide plate set		S53437-000 Slide plate set, 18-20		
Slide plate assy		S53438-000 Slide plate assy, 18-20		
Slide plate		S53430-001 Slide plate		
Binder	Double welding 	Medium-weight materials	S59291-000 Binder assy, 18W-33	S59295-000 Binder assy, 20W-37
		Light-weight materials	S59292-000 Binder assy, 18W-34	S59296-000 Binder assy, 20W-38
	Single welding 	Medium-weight materials	S59293-000 Binder assy, 18S-34	S59297-000 Binder assy, 20S-38
		Light-weight materials	S59294-000 Binder assy, 18S-35	S59298-000 Binder assy, 20S-39
Ceramic corner knife		S14051-001 Ceramic corner knife, L		
Knife base assy		S11526-001 Knife base assy, 18	S11527-001 Knife base assy, 20	
Fixed knife		S53496-001 Fixed knife, 18-20		
N/thread knife assy		S53503-001 N/Thread knife assy, 18-20		
Thread holding plate		S53509-001 Thread holding plate, 18-20		











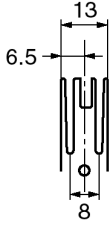
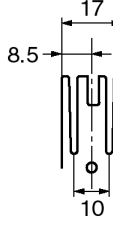
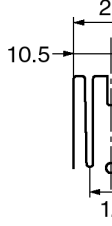



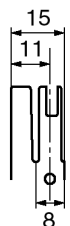

Gauge parts list (BAS-6220)

		Needle gauge: 8 mm		Needle gauge: 10 mm		Needle gauge: 12 mm					
Needle clamp set		S14607-001 Needle clamp set, 8L	S14608-001 Needle clamp set, 8R	S14609-001 Needle clamp set, 10L	S14610-001 Needle clamp set, 10R	S14611-001 Needle clamp set, 12L	S14612-001 Needle clamp set, 12R				
Needle clamp assy		S15826-001 Needle clamp assy, 8L	S15827-001 Needle clamp assy, 8R	S15830-001 Needle clamp assy, 10 L	S15831-001 Needle clamp assy, 10 R	S15834-001 Needle clamp assy, 12 L	S15835-001 Needle clamp assy, 12R				
Needle plate set		S52571-001 Needle plate set, 8		S52572-001 Needle plate set, 10		S52573-001 Needle plate set, 12					
Needle plate assy		S52561-001 Needle plate assy, 8		S52562-001 Needle plate assy, 10		S52563-001 Needle plate assy, 12					
Loop guide		S52536-001 Loop guide, 8		S52537-001 Loop guide, 10		S52538-001 Loop guide, 12					
Slide plate set		S53428-000 Slide plate set, 8-12		S53430-001 Slide plate		S53429-000 Slide plate assy, 8-12					
Binder	Double wetting			Medium-weight materials		S59271-000 Binder assy, 8W-13		S59275-000 Binder assy, 10W-17		S59279-000 Binder assy, 12W-21	
	Light-weight materials			S59272-000 Binder assy, 8W-14		S59276-000 Binder assy, 10W-18		S59280-000 Binder assy, 12W-22			
	Single wetting			Medium-weight materials		S59273-000 Binder assy, 8S-14		S59277-000 Binder assy, 10S-18		S59281-000 Binder assy, 12S-22	
				Light-weight materials	S59274-000 Binder assy, 8S-15		S59278-000 Binder assy, 10S-19		S59281-000 Binder assy, 12S-23		
Ceramic corner knife	S14050-001 Ceramic corner knife, S										
Knife base assy	S11521-001 Knife base assy, 8			S11522-001 Knife base assy, 10			S11523-001 Knife base assy, 12				
Fixed knife	S53521-001 Fixed knife, 8			S53494-001 Fixed knife, 10-12							
N/thread knife assy	S53522-001 N/Thread knife assy, 8			S53498-001 N/Thread knife assy, 10-12							
Thread holding plate	S53523-001 Thread holding plate, 8			S53507-001 Thread holding plate, 10-12							

Gauge parts list (BAS-6220)

	Needle gauge: 14 mm	Needle gauge: 16 mm	Needle gauge: 8 mm	Needle gauge: 20 mm		
Needle clamp set	S14613-001 Needle clamp set, 14L	S14615-001 Needle clamp set, 16L	S14617-001 Needle clamp set, 18L	S14619-001 Needle clamp set, 20L		
Needle clamp set	S14614-001 Needle clamp set, 14R	S14616-001 Needle clamp set, 16R	S14618-001 Needle clamp set, 18R	S14620-001 Needle clamp set, 20R		
Needle clamp assy	S15838-001 Needle clamp assy, 14L	S15842-001 Needle clamp assy, 16L	S15846-001 Needle clamp assy, 18L	S15850-001 Needle clamp assy, 20L		
Needle clamp assy	S15839-001 Needle clamp assy, 14R	S15843-001 Needle clamp assy, 16 R	S15847-001 Needle clamp assy, 18 R	S15851-001 Needle clamp assy, 20 R		
Needle plate set	S52574-001 Needle plate set, 14	S52575-001 Needle plate set, 16	S52576-001 Needle plate set, 18	S52577-001 Needle plate set, 20		
Needle plate set	S52564-001 Needle plate assy, 14	S52565-001 Needle plate assy, 16	S52566-001 Needle plate assy, 18	S52567-001 Needle plate assy, 20		
Loop guide	S52539-001 Loop guide, 14	S52540-001 Loop guide, 16	S52541-001 Loop guide, 18	S52542-001 Loop guide, 20		
Slide plate set	S53435-000 Slide plate set, 14-16	S53436-000 Slide plate assy, 14-16	S53430-000 Slide plate	S53437-000 Slide plate set, 18-20		
			S53438-000 Slide plate assy, 18-20	S53430-000 Slide plate		
Binder	Double wetting 	Medium-weight materials	S59283-000 Binder assy, 14W-25	S59287-000 Binder assy, 16W-29	S59291-000 Binder assy, 18W-33	S59295-000 Binder assy, 20W-37
		Light-weight materials	S59284-000 Binder assy, 14W-26	S59288-000 Binder assy, 16W-30	S59292-000 Binder assy, 18W-34	S59296-000 Binder assy, 20W-38
	Single wetting 	Medium-weight materials	S59285-000 Binder assy, 14S-26	S59289-000 Binder assy, 16S-30	S59293-000 Binder assy, 18S-34	S59297-000 Binder assy, 20S-38
		Light-weight materials	S59286-000 Binder assy, 14S-27	S59290-000 Binder assy, 16S-31	S59294-000 Binder assy, 18S-35	S59298-000 Binder assy, 20S-39
Ceramic corner knife	S14050-001 Ceramic corner knife, S	S14051-001 Ceramic corner knife, L	S14051-001 Ceramic corner knife, L			
Knife base assy	S11524-001 Knife base assy, 14	S11525-001 Knife base assy, 16	S11526-001 Knife base assy, 18	S11527-001 Knife base assy, 20		
Fixed knife	S53495-001 Fixed knife, 14-16		S53496-001 Fixed knife, 18-20			
N/thread knife assy	S53501-001 N/Thread knife assy, 14-16		S53503-001 N/Thread knife assy, 18-20			
Thread holding plate	S53508-001 Thread holding plate, 14-16		S53509-001 Thread holding plate, 18-20			

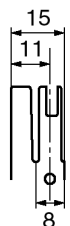
Gauge parts list (BAS-6200 • 6220)

		Needle gauge: 8 mm	Needle gauge: 10 mm	Needle gauge: 12 mm
Binder	Double welding 	Medium-weight materials S59271-000 Binder assy, 8W-13 S54651-000 Binder, 8W-13 	S59275-000 Binder assy, 10W-17 S54655-000 Binder, 10W-17 	S59279-000 Binder assy, 12W-21 S54659-000 Binder, 12W-21 
		S59272-000 Binder assy, 8W-14 S53445-000 Binder, 8W-14 	S59276-000 Binder assy, 10W-18 S53451-000 Binder, 10W-18 	S59280-000 Binder assy, 12W-22 S53455-000 Binder, 12W-22 
		S59273-000 Binder assy, 8S-14 S54653-000 Binder, 8S-14 	S59277-000 Binder assy, 10S-18 S54657-000 Binder, 10S-18 	S59281-000 Binder assy, 12S-22 S54661-000 Binder, 12S-22 
		S59274-000 Binder assy, 8S-15 S53449-000 Binder, 8S-15 	S59278-000 Binder assy, 10S-19 S53453-000 Binder, 10S-19 	S59281-000 Binder assy, 12S-23 S53457-000 Binder, 12S-23 
		Light-weight materials S59272-000 Binder assy, 8W-14 S53445-000 Binder, 8W-14 	S59276-000 Binder assy, 10W-18 S53451-000 Binder, 10W-18 	S59280-000 Binder assy, 12W-22 S53455-000 Binder, 12W-22 
		S59273-000 Binder assy, 8S-14 S54653-000 Binder, 8S-14 	S59277-000 Binder assy, 10S-18 S54657-000 Binder, 10S-18 	S59281-000 Binder assy, 12S-22 S54661-000 Binder, 12S-22 
	S59274-000 Binder assy, 8S-15 S53449-000 Binder, 8S-15 	S59278-000 Binder assy, 10S-19 S53453-000 Binder, 10S-19 	S59281-000 Binder assy, 12S-23 S53457-000 Binder, 12S-23 	

Gauge parts list (BAS-6200 • 6220)

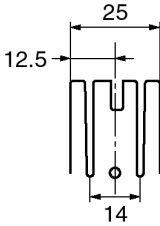
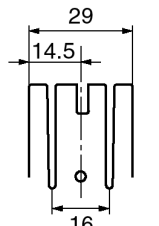
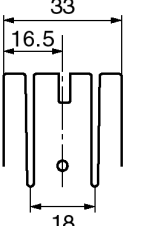
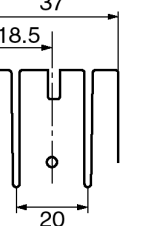
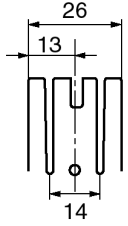
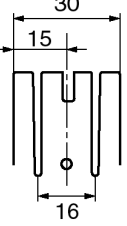
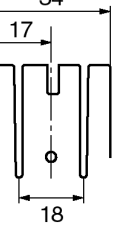
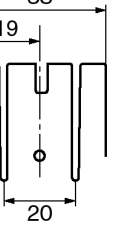
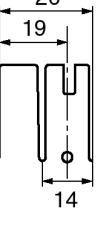
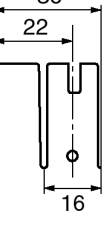
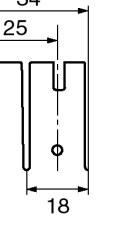
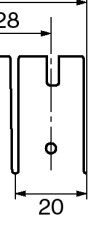
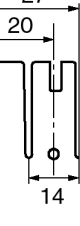
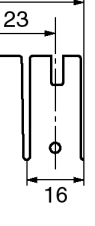
		Needle gauge: 14 mm	Needle gauge: 16 mm	Needle gauge: 18 mm	Needle gauge: 20 mm		
Binder	Double welding 	Medium-weight materials	S59283-000 Binder assy, 14W-25 S54663-000 Binder, 14W-25 	S59287-000 Binder assy, 16W-29 S54667-000 Binder, 16W-29 	S59291-000 Binder assy, 18W-33 S54671-000 Binder, 18W-33 	S59295-000 Binder assy, 20W-37 S54675-000 Binder, 20W-37 	
		Light-weight materials	S59284-000 Binder assy, 14W-26 S53459-000 Binder, 14W-26 	S59288-000 Binder assy, 16W-30 S53463-000 Binder, 16W-30 	S59292-000 Binder assy, 18W-34 S53467-000 Binder, 18W-34 	S59296-000 Binder assy, 20W-38 S53471-000 Binder, 20W-38 	
			Medium-weight materials	S59285-000 Binder assy, 14S-26 S54665-000 Binder, 14S-26 	S59289-000 Binder assy, 16S-30 S54669-000 Binder, 16S-30 	S59293-000 Binder assy, 18S-34 S54673-000 Binder, 18S-34 	S59297-000 Binder assy, 20S-38 S54677-000 Binder, 20S-38 
				Light-weight materials	S59286-000 Binder assy, 14S-27 S53461-000 Binder, 14S-27 	S59290-000 Binder assy, 16S-31 S53465-000 Binder, 16S-31 	S59294-000 Binder assy, 18S-35 S53469-000 Binder, 18S-35 